<4G6> ENGINE

ENGINE <4G6>

CONTENTS

11109000399

GENERAL INFORMATION	3	Lash Adjuster Check	14
SERVICE SPECIFICATIONS	3	CAMSHAFT OIL SEAL	16
SEALANT	5	OIL PAN, OIL SCREEN	19
SPECIAL TOOLS	5	CYLINDER HEAD GASKET	21
ON-VEHICLE SERVICE	7	TIMING BELT, TIMING BELT B	26
Drive Belt Tension Check and Adjustment	7	CRANKSHAFT FRONT OIL SEAL	32
Ignition Timing Check and Adjustment	10	CRANKSHAFT REAR OIL SEAL	35
Idle Speed Check	11	ENGINE ASSEMBLY	37
Idle Mixture Check	11		
Compression Pressure Check	12		
Manifold Vacuum Check	13		



GENERAL INFORMATION

11100010322

Items		4G63	4G64
Total displacement mℓ		1,997	2,351
Bore × Stroke mm		85.0 x 88.0	86.5 x 100.0
Compression ratio		9.5	9.5
Combustion chamber		Pentroof type	Pentroof type
Camshaft arrangement		SOHC	SOHC
Number of valve	Intake	8	8
	Exhaust	8	8
Valve timing	Intake	Opening	BTDC 11°
		Closing	ABDC 53°
	Exhaust	Opening	BBDC 63°
		Closing	ATDC 21°
Fuel system		Electronic control multipoint fuel injection	Electronic control multipoint fuel injection
Rocker arm		Roller type	Roller type
Auto-lash adjuster		Equipped	Equipped

SERVICE SPECIFICATIONS

11100030342

Items			Standard value	Limit
Alternator drive belt tension	Tension N	When checked	294–490	–
		When a used belt is installed	343–441	–
		When a new belt is installed	490–686	–
	Deflection (Reference value) mm	When checked	7.0 – 9.0	–
		When a used belt is installed	7.5 – 8.5	–
		When a new belt is installed	5.5 – 7.5	–
Power steering oil pump drive belt tension	Tension N	When checked	294 – 490	–
		When a used belt is installed	343 – 441	–
		When a new belt is installed	490 – 686	–
	Deflection (Reference value) mm	When checked	5.5 – 7.5	–
		When a used belt is installed	6.0 – 7.0	–
		When a new belt is installed	4.0 – 6.0	–

Items		Standard value	Limit	
A/C compressor drive belt tension	Tension N	When checked	355 – 445	–
		When a used belt is installed	355 – 445	–
		When a new belt is installed	530 – 620	–
	Deflection (Reference value) mm	When checked	6.0 – 7.0	–
		When a used belt is installed	6.0 – 7.0	–
		When a new belt is installed	4.5 – 5.5	–
Basic ignition timing		5° BTDC±2°	–	
Idle speed r/min		750±100	–	
CO contents %		0.5 or less	–	
HC contents ppm		100 or less	–	
Compression pressure (250–400 r/min) kPa	4G63	1,270	min. 960	
	4G64	1,320	min. 1,000	
Compression pressure difference of all cylinder kPa		–	max. 100	
Intake manifold vacuum kPa		min. 60	–	
Cylinder head bolt shank length mm		–	99.4	
Auto-tensioner push rod movement mm		Within 1.0	–	
Timing belt tension torque Nm (Reference value)		3.5	–	
Auto tensioner rod protrusion mm		2.5 – 3.0	–	

SEALANT

11100050218

Item	Specified sealant	Remark
Oil pan	MITSUBISHI GENUINE PART MD970389 or equivalent	Semi-drying sealant

SPECIAL TOOLS

11100060310

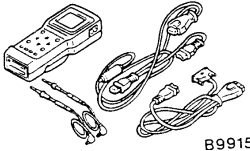
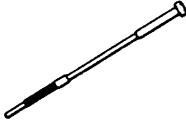
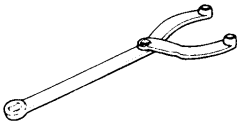
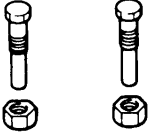
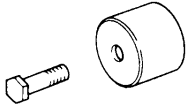
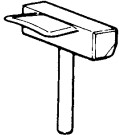
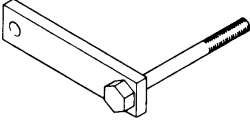
Tool	Number	Name	Use
 B991502	MB991502	MUT-II sub assembly	<ul style="list-style-type: none"> • Checking the idle speed • Erasing of diagnosis code
	MD998738	Adjusting screw	<ul style="list-style-type: none"> • Holding the auto tensioner • Timing belt tension adjustment
	MB990767	End yoke holder	Holding the camshaft sprocket
	MD998719 or MD998754	Crankshaft pulley holder pin	
	MD998713	Camshaft oil seal installer	Press-in of the camshaft oil seal
	MD998727	Oil pan remover	Removal of the oil pan
	MD998781	Fly wheel stopper	Securing the flywheel <M/T> or drive plate <A/T>

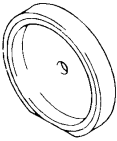
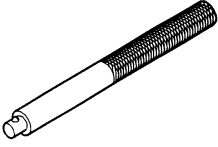
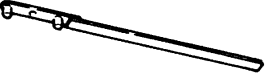
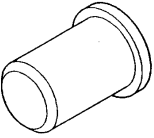
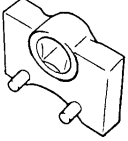
Tool	Number	Name	Use
	MD998776	Crankshaft rear oil seal installer	Press-fitting the crankshaft rear oil seal
	MB990938	Handle	Press-fitting the crankshaft rear oil seal
	MD998747	Crankshaft pulley holder	Supporting of crankshaft sprocket
	MD998375	Crankshaft front oil seal installer	Press-fitting the crankshaft front oil seal
	MD998767	Tension pulley socket wrench	Timing belt tension adjustment

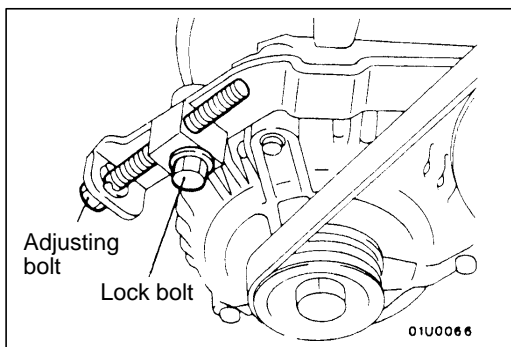
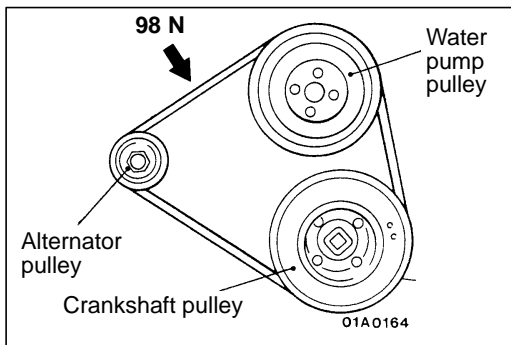
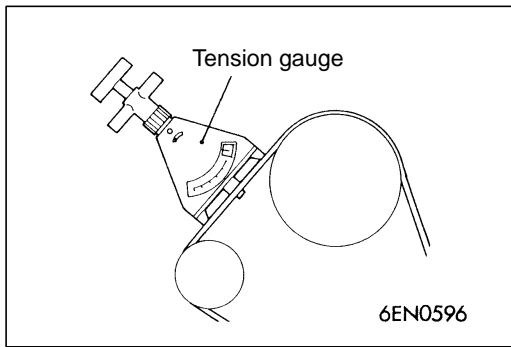

ON-VEHICLE SERVICE

11100090326

DRIVE BELT TENSION CHECK AND ADJUSTMENT

ALTERNATOR DRIVE BELT TENSION CHECK

Use a belt tension gauge to check that the belt tension is at the standard value at a point half-way between the two pulleys as shown in the illustration. In addition, press this section with a force of 98 N and check that the amount of belt deflection is at the standard value.

Standard value:

Tension N	294–490
Deflection (Reference value) mm	7.0 – 9.0

ALTERNATOR DRIVE BELT TENSION ADJUSTMENT

1. Loosen the nut of the alternator pivot bolt.
2. Loosen the lock bolt.
3. Use the adjusting bolt to adjust the belt tension and belt deflection to the standard values.

Standard value:

Items	When a used belt is installed	When a new belt is installed
Tension N	343–441	490–686
Deflection (Reference value) mm	7.5 – 8.5	5.5 – 7.5

4. Tighten the nut of the alternator pivot bolt.

Tightening torque: 22 Nm

5. Tighten the lock bolt.

Tightening torque: 22 Nm

6. Tighten the adjusting bolt.

Tightening torque: 9.8 Nm

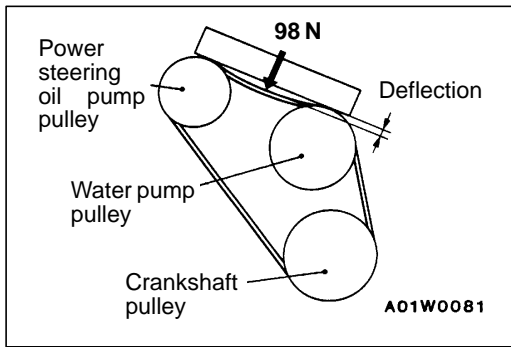

POWER STEERING OIL PUMP DRIVE BELT TENSION CHECK AND ADJUSTMENT

11100110145

1. Use a belt tension gauge to check that the belt tension is at the standard value at a point half-way between the two pulleys (indicated by an arrow in the illustration). In addition, press this section with a force of 98 N and check that the amount of belt deflection is at the standard value.

Standard value:

Items	When checked	When a used belt is installed	When a new belt is installed
Tension N	294 – 490	343 – 441	490 – 686
Deflection (Reference value) mm	5.5 – 7.5	6.0 – 7.0	4.0 – 6.0

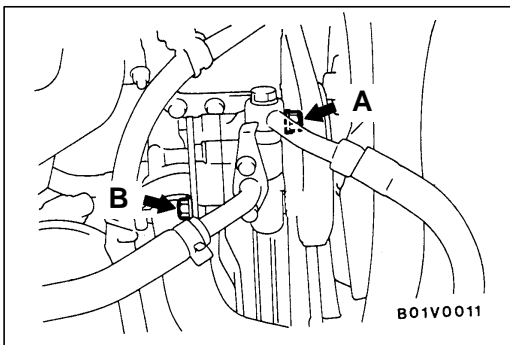

2. If the tension or deflection is outside the standard value, adjust by the following procedure.

- (1) Loosen power steering oil pump fixing bolts A and B.
- (2) Move power steering oil pump tension belt moderately and adjust tension.
- (3) Tighten fixing bolts A and B.

Tightening torque: 22 Nm

- (4) Check the belt deflection amount and tension, and readjust if necessary.

Caution

Check after turning the crankshaft once or more clockwise (right turn).

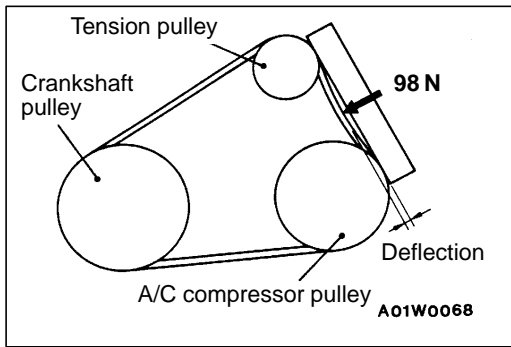

AIR CONDITIONER COMPRESSOR DRIVE BELT TENSION CHECK AND ADJUSTMENT

11100100135

1. Use a belt tension gauge to check that the belt tension is at the standard value at a point half-way between the two pulleys (indicated by an arrow in the illustration). In addition, press this section with a force of 98 N and check that the amount of belt deflection is at the standard value.

Standard value:

Items	When checked	When a used belt is intalled	When a new belt is installed
Tension N	355 – 445	355 – 445	530 – 620
Deflection (Reference value) mm	6.0 – 7.0	6.0 – 7.0	4.5 – 5.5

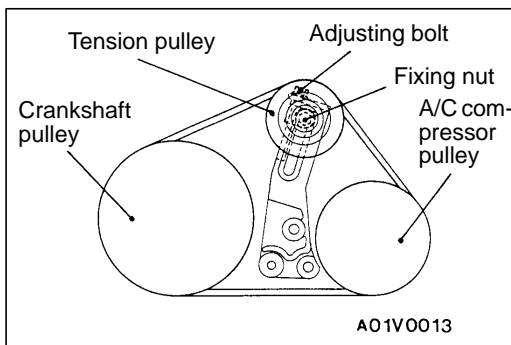

2. If the tension or deflection is outside the standard value, adjust by the following procedure.
 - (1) Loosen tension pulley fixing nut.
 - (2) Adjust belt tension with adjusting bolt.
 - (3) Tighten fixing nut.
 - (4) Check the belt deflection amount and tension, and readjust if necessary.

Caution

Check after turning the crankshaft once or more clockwise (right turn).

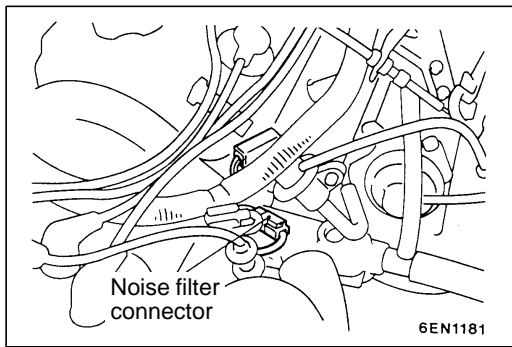

IGNITION TIMING CHECK AND ADJUSTMENT

11100170167

1. Before inspection, set the vehicle to the pre-inspection condition.
2. Insert a paper clip into the noise filter connector (1 pin) as shown in the illustration at left.
3. Connect a primary-voltage-detection type of tachometer to the paper clip.

NOTE

Do not use the MUT-II.

If tested with the MUT-II connected to the diagnosis connector, the ignition timing will not be the basic timing but be ordinary timing.

4. Set up a timing light.
5. Start the engine and run at idle.
6. Check that engine idle speed is within the standard value.

Standard value: 750 ± 100 r/min

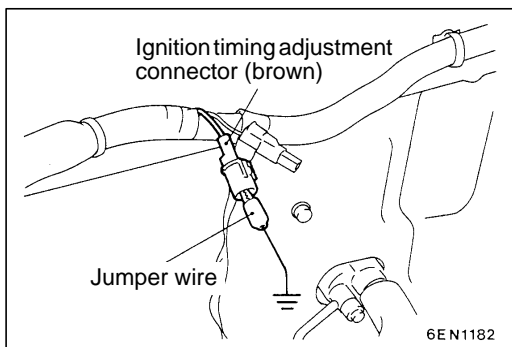

7. Turn the ignition switch to OFF.
8. Remove the waterproof connector from the ignition timing adjustment connector (brown).
9. Connect the jumper wire with the clip to the ignition timing adjustment terminal, and earth this to the body as illustrated.

NOTE

Earthing this terminal sets the engine to the basic ignition timing.

10. Start the engine and run it at idle.

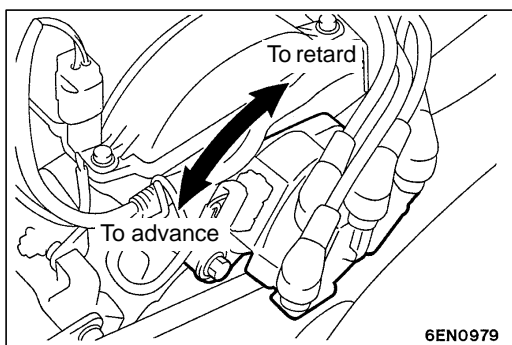

11. Check that basic ignition timing is within the standard value.

Standard value: 5° BTDC±2°

12. If not within the standard value, loosen distributor fixing bolts and adjust by rotating distributor body.
13. Tighten mounting bolts after adjusting.

Tightening torque: 12 Nm

14. Stop the engine, remove the jumper wire from the ignition timing adjustment connector (brown), and return the connector to its original condition.
15. Start the engine and check that ignition timing at the standard value.

Standard value: Approx. 10° BTDC

NOTE

1. Ignition timing is variable within about ± 7°, even under normal operating.
2. And it is automatically further advanced by about 5° from 10° BTDC at higher altitudes.

16. Attach a sealing tape to the fixing bolt and nut only for vehicles for Switzerland.

NOTE

Sealing tape is attached to all new vehicles.

IDLE SPEED CHECK

11100190330

1. Before inspection, set the vehicle to the pre-inspection condition.
2. Check the basic ignition timing. Adjust if necessary.
Standard value: 5° BTDC±2°
3. After turning the ignition switch to OFF, connect the MUT-II to the diagnosis connector.
4. Start the engine and run it at idle.
5. Run the engine at idle for 2 minutes.
6. Check the idle speed.

Curb idle speed: 750±100 r/min

NOTE

The idle speed is controlled automatically by the idle speed control (ISC) system.

7. If the idle speed is outside the standard value, inspect the MPI components by referring to GROUP 13A – Troubleshooting.

IDLE MIXTURE CHECK

11100210265

1. Before inspection, set the vehicle to the pre-inspection condition.
2. Check that the basic ignition timing is within the standard value.

Standard value: 5° BTDC±2°

3. Turn the ignition switch to OFF and connect the MUT-II to the diagnosis connector.
4. Start the engine and run it at 2,500 r/min for 2 minutes.
5. Set the CO, HC tester.
6. Check the CO contents and the HC contents at idle.

Standard value:

CO contents: 0.5% or less

HC contents: 100 ppm or less

7. If there is a deviation from the standard value, check the following items:
 - Diagnosis output
 - Closed-loop control (When the closed-loop control is normal, the output signal of the oxygen sensor changes between 0–400 mV and 600–1,000 mV at idle.)

- Fuel pressure
- Injector
- Ignition coil, spark plug cable, spark plug
- Leak in the EGR system and in the EGR valve
- Evaporative emission control system
- Compression pressure

NOTE

Replace the three way catalyst when the CO and HC contents are not within the standard value, even though the result of the inspection is normal on all items.

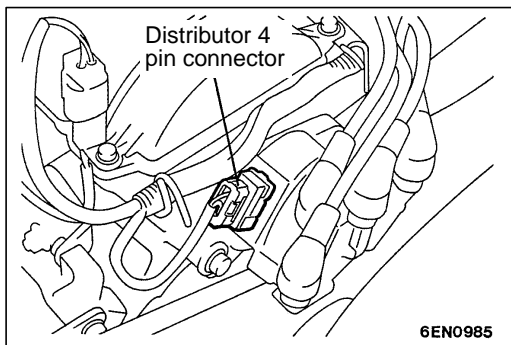
**COMPRESSION PRESSURE CHECK**

11100260352

1. Before inspection, check that the engine oil, starter and battery are normal. In addition, set the vehicle to the pre-inspection condition.
2. Disconnect the spark plug cables.
3. Remove all of the spark plugs.
4. Disconnect the distributor connector.

NOTE

Doing this will prevent the engine-ECU from carrying out ignition and fuel injection.

5. Cover the spark plug hole with a shop towel etc., and after the engine has been cranked, check that no foreign material is adhering to the shop towel.

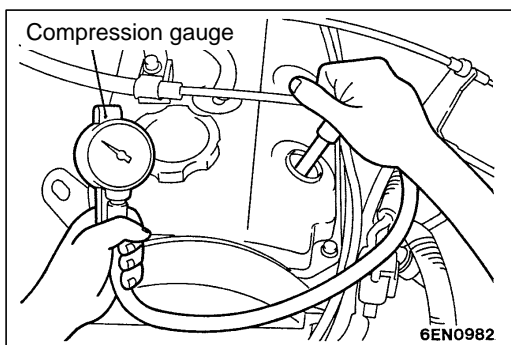
**Caution**

1. **Keep away from the spark plug hole when cranking.**
2. **If compression is measured with water, oil, fuel, etc., that has come from cracks inside the cylinder, these materials will become heated and will gush out from the spark plug hole, which is dangerous.**
6. Set compression gauge to one of the spark plug holes.
7. Crank the engine with the throttle valve fully open and measure the compression pressure.

Standard value (at engine speed of 250–400 r/min):

4G63: 1,270 kPa

4G64: 1,320 kPa

Limit (at engine speed of 250–400 r/min):

4G63: min. 960 kPa

4G64: min. 1,000 kPa

8. Measure the compression pressure for all the cylinders, and check that the pressure differences of the cylinders are below the limit.

Limit: max. 100 kPa

9. If there is a cylinder with compression or a compression difference that is outside the limit, pour a small amount of engine oil through the spark plug hole, and repeat the operations in steps (7) and (8).
 - (1) If the compression increases after oil is added, the cause of the malfunction is a worn or damaged piston ring and/or cylinder inner surface.
 - (2) If the compression does not rise after oil is added, the cause is a burnt or defective valve seat, or pressure is leaking from the gasket.
10. Connect the distributor connector.
11. Install the spark plugs and spark plug cables.
12. Use the MUT-II to erase the diagnosis codes.

NOTE

This will erase the problem code resulting from the distributor connector being disconnected.

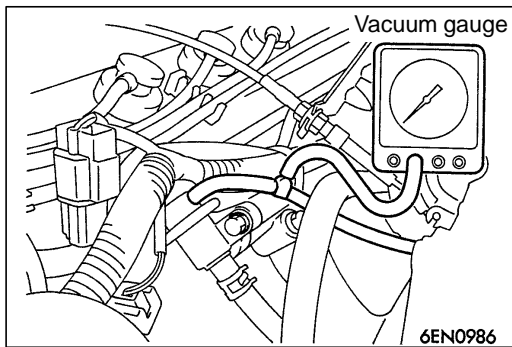

MANIFOLD VACUUM CHECK

11100270270

1. Start the engine and allow it to warm up until the temperature of the engine coolant reaches 80 to 95°C.
2. Connect a tachometer.
3. Attach a three-way union to the vacuum hose between the fuel pressure regulator and the air intake plenum, and connect a vacuum gauge.
4. Start the engine and check that idle speed is within specification. Then read off the vacuum gauge.

Standard value: min. 60 kPa

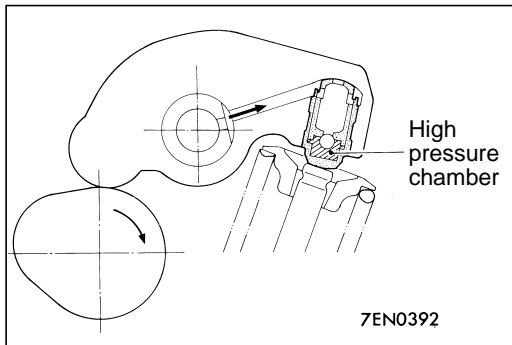
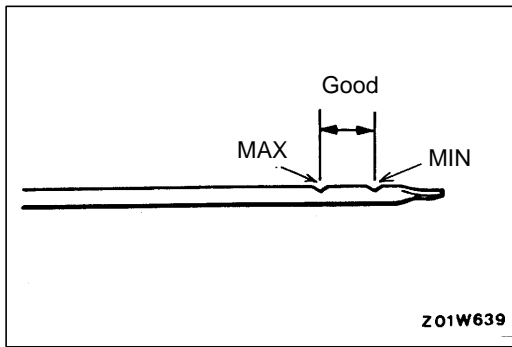

LASH ADJUSTER CHECK

11100290214

NOTE

Soon after the engine is started or while it is running, abnormal noise (clattering) which may be attributed to the adjuster sounds but does not stop. In this case, check the following.

1. Check the engine oil, and refill or replace oil if necessary.

NOTE

1. If the oil amount is small, air will be sucked from the oil strainer and mixed in the oil passage.
2. If the oil amount is excessive, the oil will be stirred by the crank and mixed with a large amount of air.
3. Air and oil can not be separated easily in the deteriorated oil, and the amount of air mixed in the oil increases.

If such mixed-in air enters the high pressure chamber in the lash adjuster, the air in the high-pressure chamber will be compressed while the valve is opened, the lash adjuster will be excessively compressed and abnormal noise will be produced when the valve is closed.

This is the same phenomenon which occurs when the valve clearance is improperly adjusted to be excessively large.

However, it will return to be normal if the air entrapped in the adjuster is released in this case.

2. Start the engine, and slowly race* it several times (10 times or less).

If the abnormal noise is eliminated by racing the engine, it means that the air is released from the high-pressure chamber of the lash adjuster and the function of the lash adjuster is returned to normal.

* Gradually increase the engine speed from the idle speed to 3,000 r/min (for 30 seconds), and then gradually slow down the engine to the idling speed (for 30 seconds).

NOTE

1. If the vehicle is parked on a slope for a long time, the oil will be sometimes reduced in the lash adjuster, and air will enter the high-pressure chamber when the engine is started.
2. After the vehicle is parked for a long time, the oil will go out of the oil passage. Since it takes a little time to supply oil to the lash adjuster, air sometimes enters the high-pressure chamber.

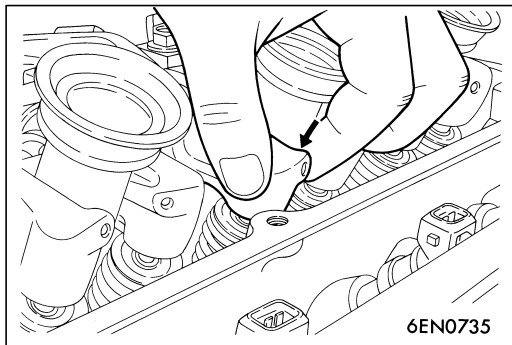
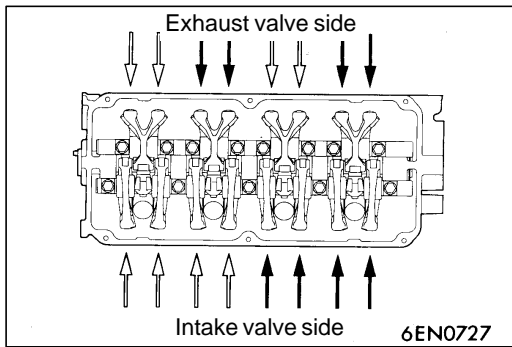

3. If any abnormal noise is not eliminated by racing, check the lash adjuster.
 - (1) Stop the engine.
 - (2) Set the engine so that cylinder No. 1 is positioned at the top dead centre of the compression.
 - (3) Press the rocker arm at the area indicated by the white arrow mark to check whether the rocker arm is lowered or not.
 - (4) Slowly turn the crankshaft 360 degrees clockwise.
 - (5) In the same procedure as step (3), check the rocker arm at the area indicated by the black arrow mark.

- (6) If the rocker arm is easily lowered when the section directly above the lash adjuster of the rocker arm is pressed, the lash adjuster is defective, so replace it.

Moreover, if it is felt to be so hard that the rocker arm is not lowered when it is pressed, the lash adjuster is normal. Check for other causes of the abnormality. For Y-formed rocker arm at the exhaust valve side, if one lash adjuster is defective and the other is normal, it is impossible to press the rocker arm. In this case, remove the lash adjuster and carry out the leak down test.

NOTE

1. A leak down test can be performed to accurately determine whether the lash adjuster is defective or not.
2. For the procedures for the leak down test and air bleeding of the lash adjuster, refer to the Engine Workshop Manual.

CAMSHAFT OIL SEAL

REMOVAL AND INSTALLATION

Pre-removal and Post-installation Operation
 • Distributor Removal and Installation

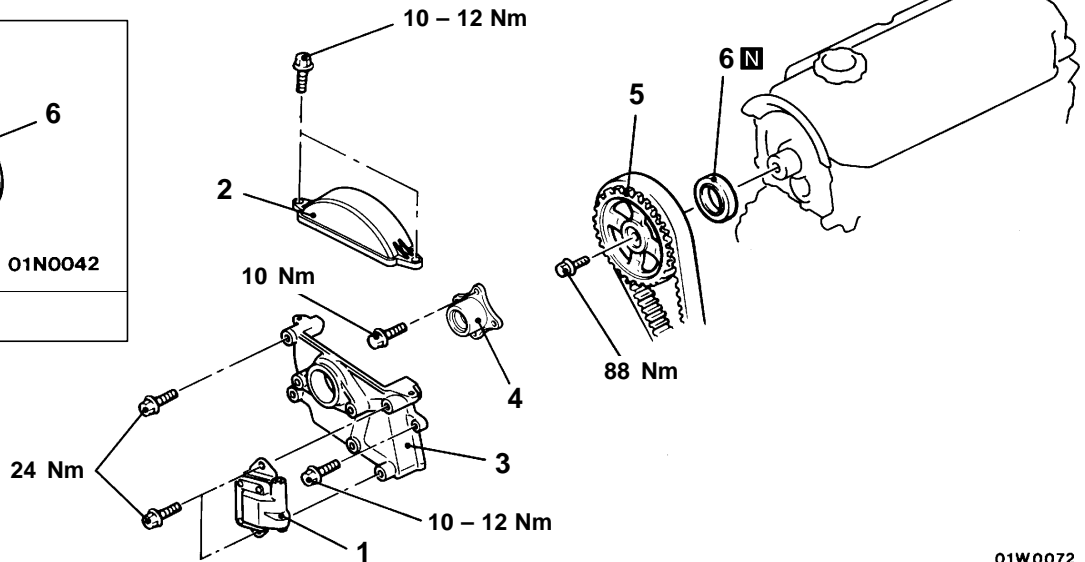
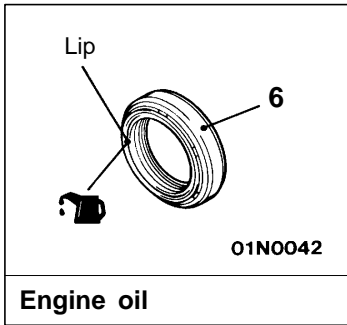

01W0072
0000851

Removal steps

1. Ignition coil
2. Timing belt upper cover assembly
3. Distributor bracket

- | | | |
|-----|-----|-----------------------------|
| ◀A▶ | ▶C▶ | 4. Camshaft sprocket spacer |
| ▶B▶ | ▶B▶ | 5. Camshaft sprocket |
| ▶B▶ | ▶A▶ | 6. Camshaft oil seal |

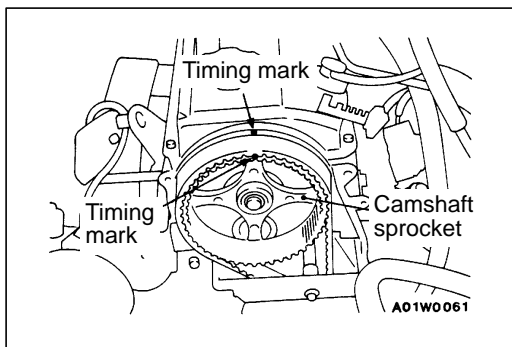

REMOVAL SERVICE POINTS

◀A▶ CAMSHAFT SPROCKET REMOVAL

1. Rotate the crankshaft in the forward (right) direction and align the timing mark.

Caution

The crankshaft must always be rotated in the forward direction only.

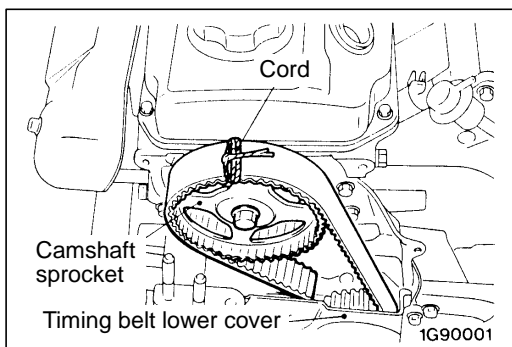

2. Tie the camshaft sprocket and timing belt with a cord so that the position of the camshaft sprocket will not move with respect to the timing belt.

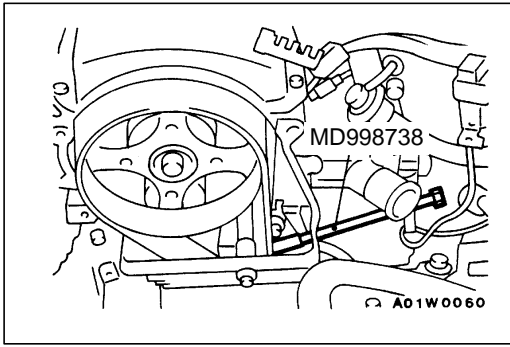

3. Insert the special tool into the rubber plug hole in the timing belt cover assembly rear and turn it gently. Stop turning the special tool when it can no longer be turned gently.

NOTE

This work will make the end of the special tool touch the tensioner arm. So the auto tensioner will stop and the timing belt tension will not vary.

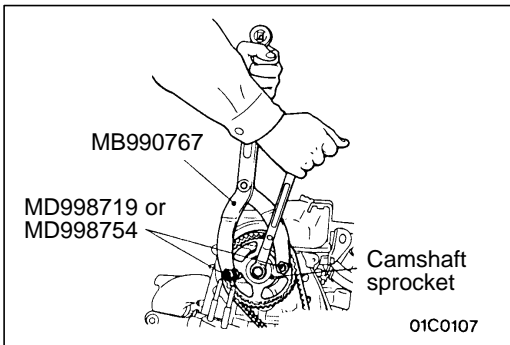

4. Use the special tool to remove the camshaft sprocket with the timing belt attached.

Caution

After removing the camshaft sprocket, be sure not to rotate the crankshaft.

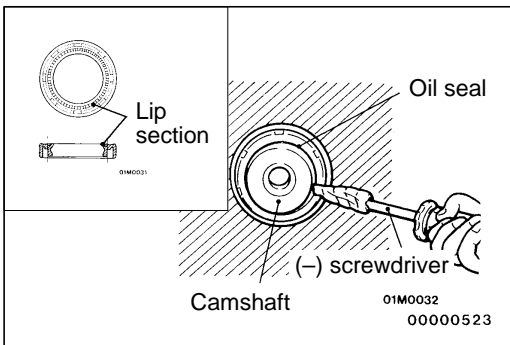
**◀B▶ CAMSHAFT OIL SEAL REMOVAL**

1. Make a notch in the oil seal lip section with a knife, etc.
2. Cover the end of a (-) screwdriver with a rag and insert into the notched section of the oil seal, and lever out the oil seal to remove it.

Caution

Be careful not to damage the camshaft and the cylinder head.

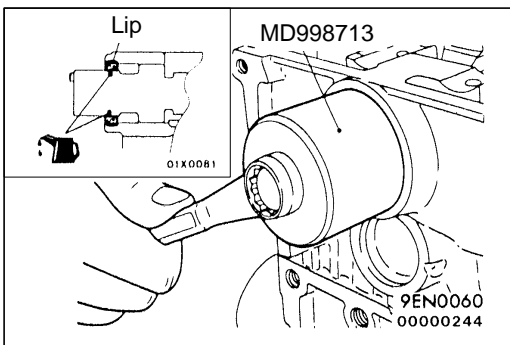
**INSTALLATION SERVICE POINTS****▶A◀ CAMSHAFT OIL SEAL INSTALLATION**

1. Apply engine oil to the camshaft oil seal lip.
2. Use the special tool to press-fit the camshaft oil seal.

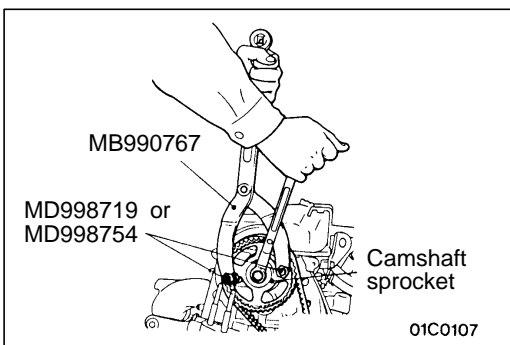
**▶B◀ CAMSHAFT SPROCKET INSTALLATION**

1. Use the special tool to stop the camshaft sprocket from turning, and then install the camshaft sprocket bolt.
2. Remove the special tool from the rubber plug hole.
3. Remove the cord which binds the camshaft sprocket and timing belt.

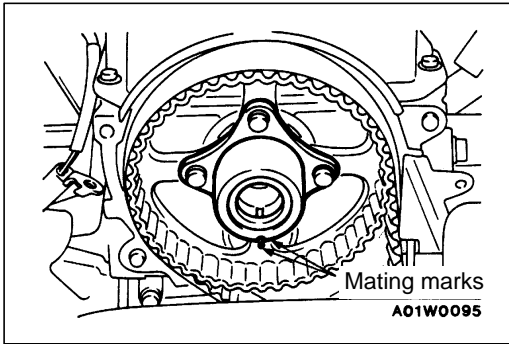
**▶◀ CAMSHAFT SPROCKET SPACER INSTALLATION**

Align the mating marks on the camshaft sprocket and the camshaft sprocket spacer (groove), and then install them.

OIL PAN AND OIL SCREEN

11200250185

REMOVAL AND INSTALLATION

Pre-removal and Post-installation Operation

- Under Cover Removal and Installation
- Engine Oil Draining and Refilling
(Refer to GROUP 12 – On-vehicle Service.)

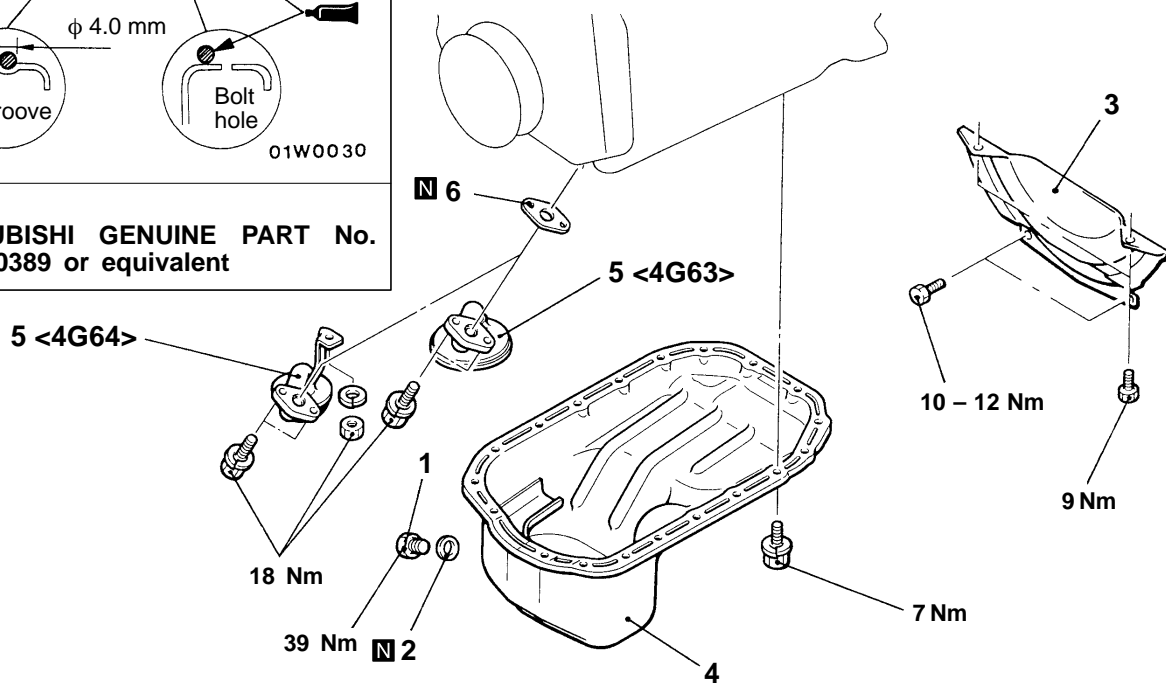
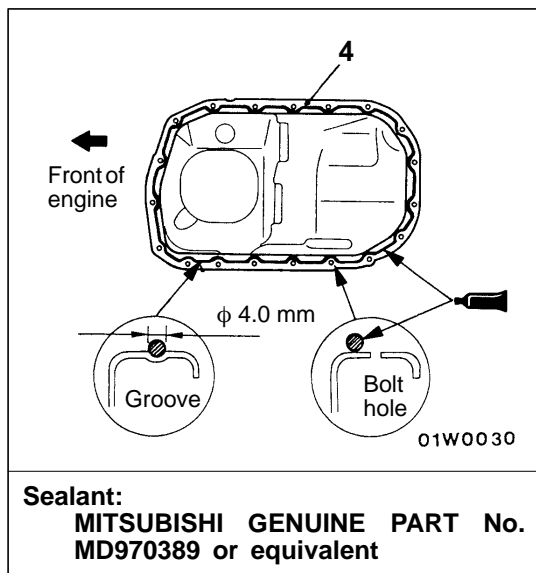

01V0085
00005182

Removal steps

- | | | | |
|-----|--|---------|--|
| ▶B◀ | <ol style="list-style-type: none"> 1. Drain plug 2. Drain plug gasket 3. Bell housing cover | ◀A▶ ▶A◀ | <ol style="list-style-type: none"> 4. Oil pan 5. Oil screen 6. Gasket |
|-----|--|---------|--|

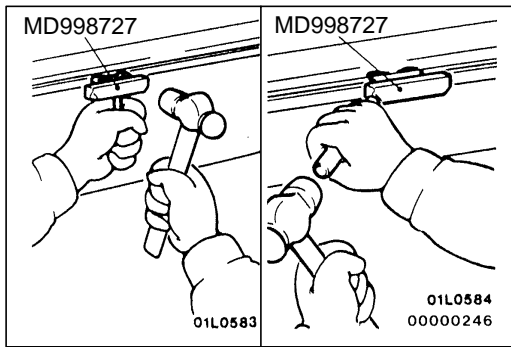

REMOVAL SERVICE POINT

◀A▶ OIL PAN REMOVAL

After removing the oil pan mounting bolts, remove the oil pan with the special tool and a brass bar.

Caution

Perform this slowly to avoid deformation of the oil pan flange.

INSTALLATION SERVICE POINTS

▶A▶ OIL PAN INSTALLATION

1. Remove sealant from oil pan and cylinder block mating surfaces.
2. Degrease the sealant-coated surface and the engine mating surface.
3. Apply the specified sealant around the gasket surface of oil pan.

Specified sealant: MITSUBISHI GENUINE PART No. MD970389 or equivalent

NOTE

The sealant should be applied in a continuous bead approximately 4 mm in diameter.

4. Assemble oil pan to cylinder block within 15 minutes after applying the sealant.

Caution

After installing the oil pan, wait at least 1 hour before starting the engine.

Be careful when installing, as the bolts indicated in the illustration have different lengths from the other bolts.

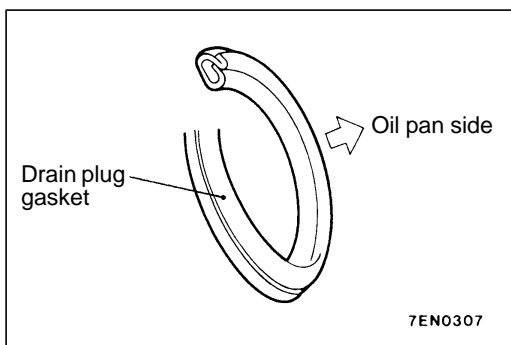
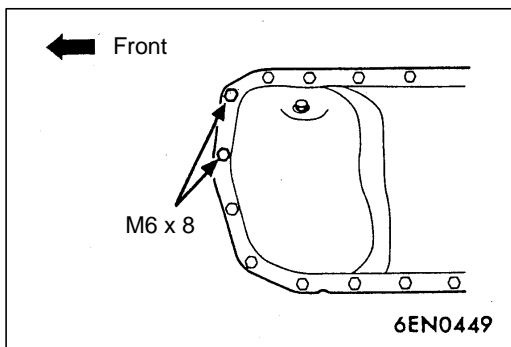

▶B▶ DRAIN PLUG GASKET INSTALLATION

Install the drain plug gasket in the direction so that it faces as shown in the illustration.

INSPECTION

11200260041

- Check oil pan for cracks.
- Check oil pan sealant-coated surface for damage and deformation.
- Check oil screen for cracked, clogged or damaged wire net and pipe.

CYLINDER HEAD GASKET

11200400351

REMOVAL AND INSTALLATION

Pre-removal Operation

- Engine Coolant Draining
(Refer to GROUP 14 – On-vehicle Service.)
- Fuel Line Pressure Releasing
(Refer to GROUP 13A – On-vehicle Service.)
- Battery Removal
- Air Cleaner Assembly Removal
(Refer to GROUP 15.)
- Distributor Removal

Post-installation Operation

- Distributor installation
- Air Cleaner Assembly installation
(Refer to GROUP 15.)
- Battery Installation
- Engine Coolant Refilling
(Refer to GROUP 14 – On-vehicle Service.)
- Accelerator Cable Adjustment
(Refer to GROUP 17 – On-vehicle Service.)
- Throttle Cable Adjustment
(Refer to GROUP 23 – On-vehicle Service.)

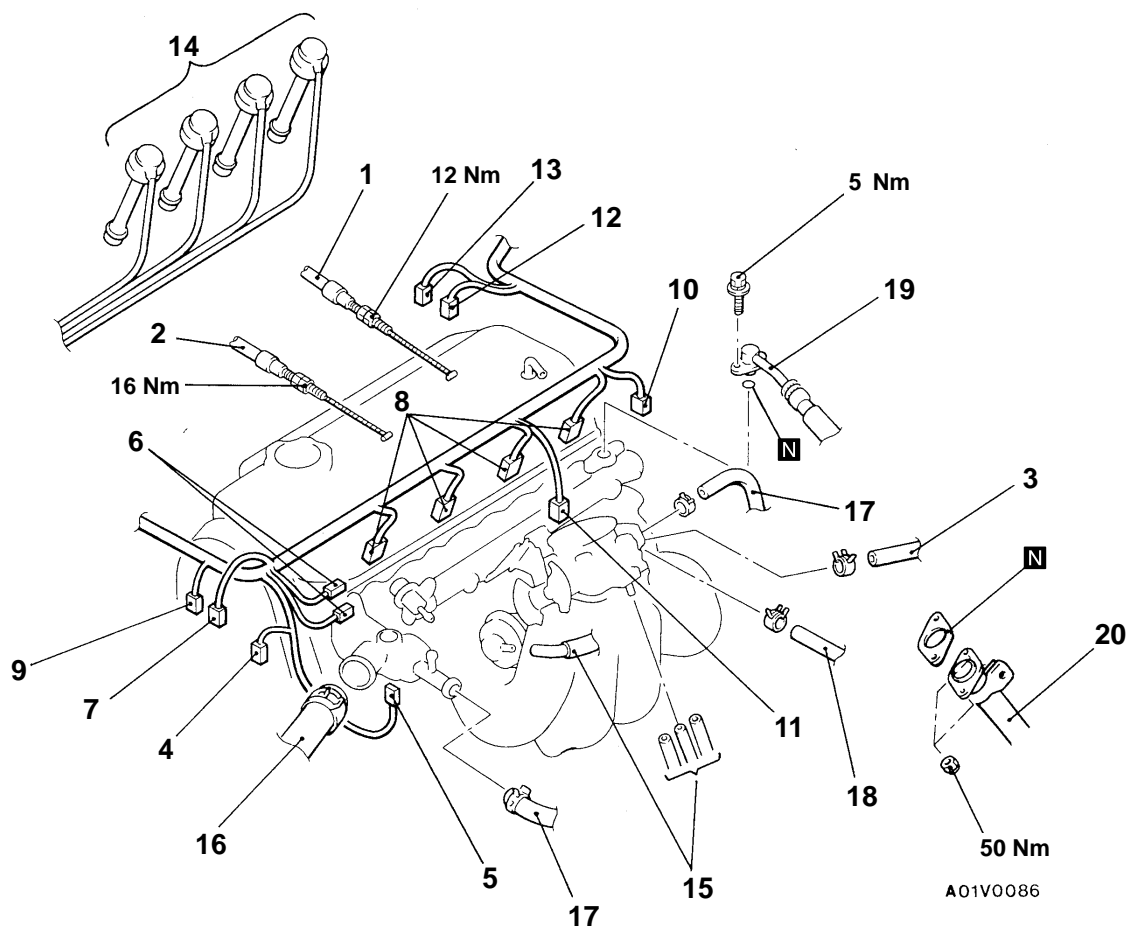
**Removal steps**

1. Accelerator cable connection
2. Throttle cable connection <A/T>
3. Brake booster vacuum hose connection
4. Ignition coil connector
5. Engine coolant temperature sensor connector
6. Noise filter connector
7. Power transistor connector
8. Injector connectors
9. Capacitor connector
10. Throttle position sensor connector
11. Idle speed control servo connector
12. Engine coolant temperature gauge unit connector
13. Engine coolant temperature switch connector <A/T>
14. Spark plug cable
15. Vacuum hose connection
16. Radiator upper hose connection
17. Water hose connections
18. Fuel return hose connection
19. High-pressure fuel hose connection
20. Front exhaust pipe connection

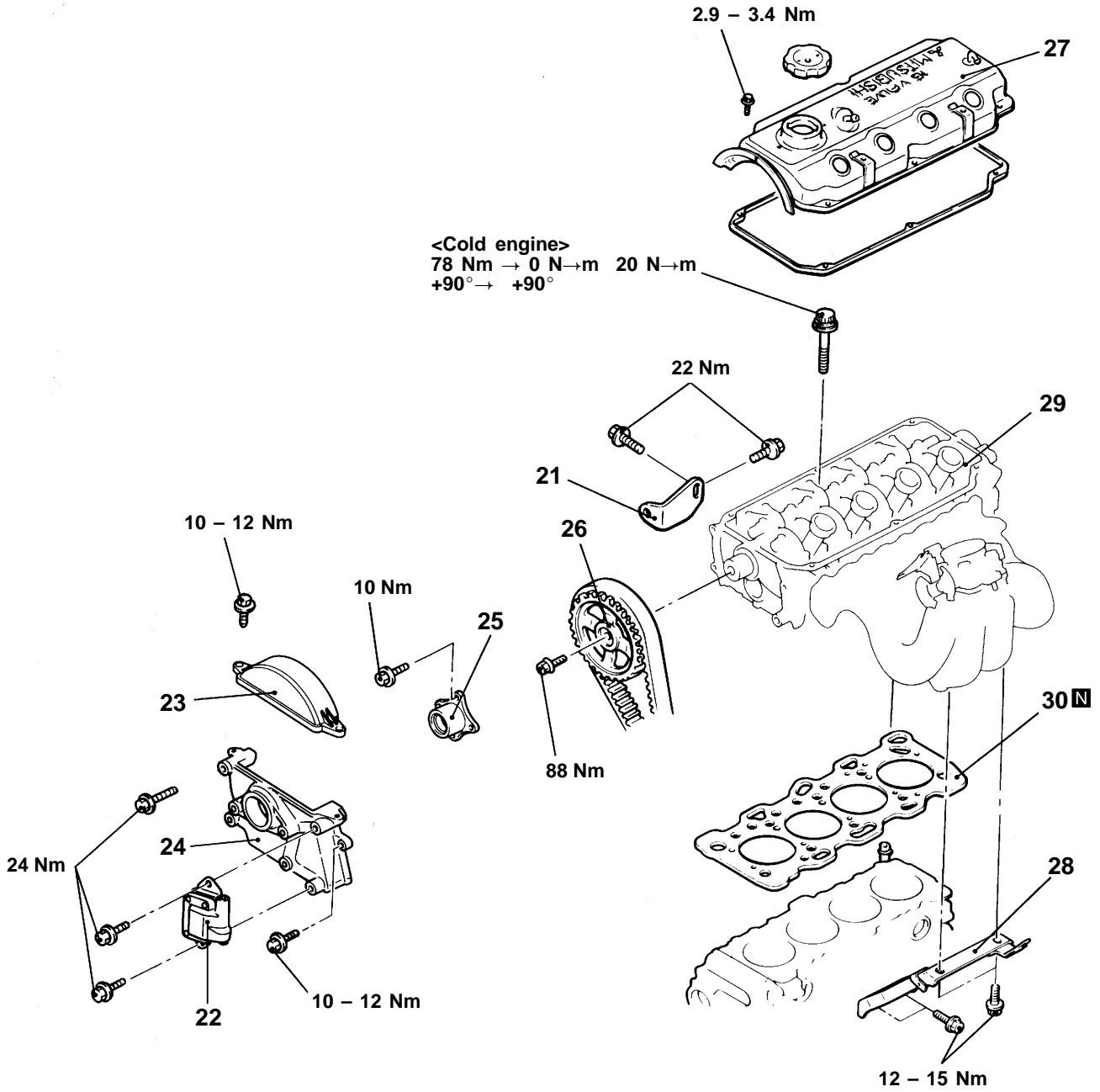

A01W0100

- ▶D◀ 21. Power steering pump mount bracket
- 22. Ignition coil
- 23. Timing belt upper cover assembly
- 24. Distributor bracket
- ▶D◀ 25. Camshaft sprocket spacer

- ◀A▶ ▶C◀ 26. Camshaft sprocket
- 27. Rocker cover
- 28. Intake manifold stay
- ◀B▶ ▶B◀ 29. Cylinder head assembly
- ▶A◀ 30. Cylinder head gasket

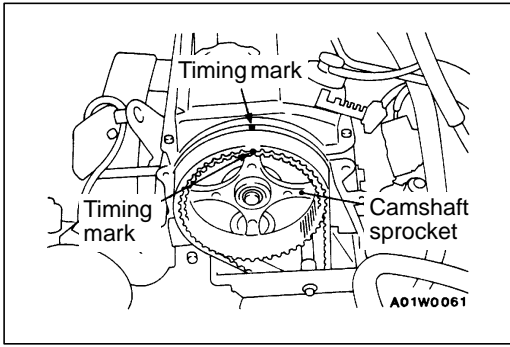

REMOVAL SERVICE POINTS

◀A▶ CAMSHAFT SPROCKET REMOVAL

1. Rotate the crankshaft in the forward (right) direction and align the timing mark.

Caution

The crankshaft must always be rotated in the forward direction only.

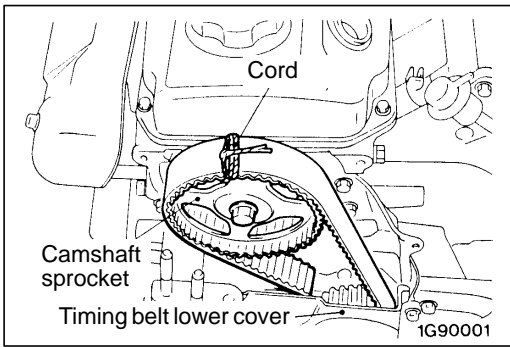

2. Tie the camshaft sprocket and timing belt with a cord so that the position of the camshaft sprocket will not move with respect to the timing belt.

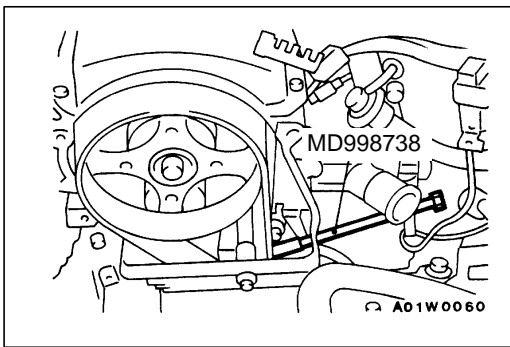

3. Insert the special tool into the rubber plug hole in the timing belt cover assembly rear and turn it gently. Stop turning the special tool when it can no longer be turned gently.

NOTE

This work will make the end of the special tool touch the tensioner arm. So the auto tensioner will stop and the timing belt tension will not vary.

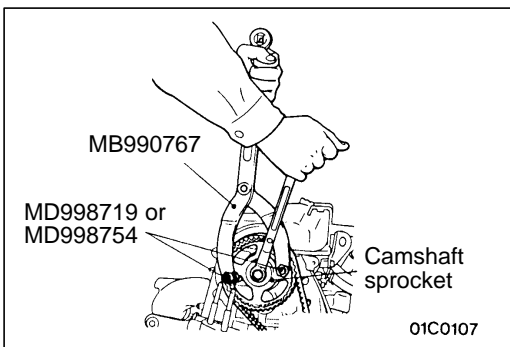

4. Use the special tool to remove the camshaft sprocket with the timing belt attached.

Caution

After removing the camshaft sprocket, be sure not to rotate the crankshaft.

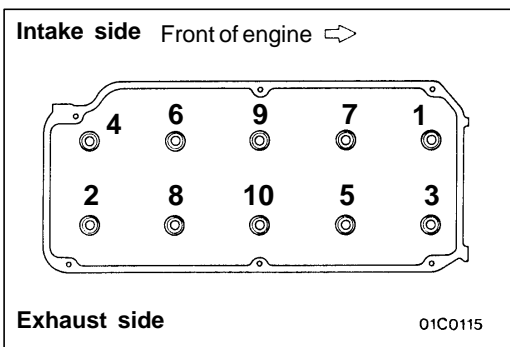

◀B▶ CYLINDER HEAD ASSEMBLY REMOVAL

Loosen the bolts in 2 or 3 steps in order of the numbers shown in the illustration, and remove the cylinder head assembly.

Caution

Because the plug guides cannot be replaced by themselves, be careful not to damage or deform the plug guides when removing the cylinder head bolts.

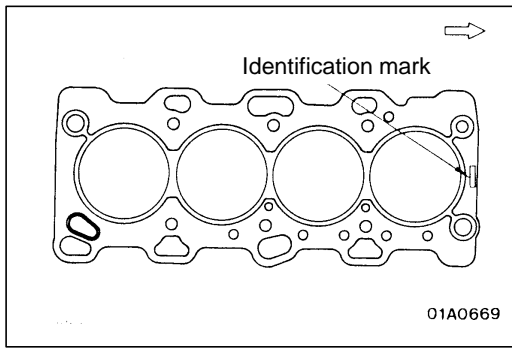

INSTALLATION SERVICE POINTS

►A◄ CYLINDER HEAD GASKET INSTALLATION

1. Wipe off all oil and grease from the gasket mounting surface.
2. Install the gasket to the cylinder block with the identification mark facing upwards.

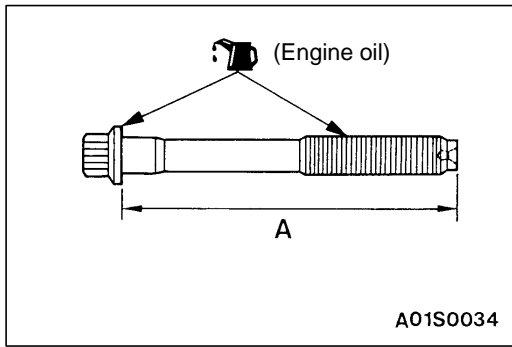

►B◄ CYLINDER HEAD ASSEMBLY INSTALLATION

1. When installing the cylinder head bolts, the length below the head of the bolts should be within the limit. If it is outside the limit, replace the bolts.

Limit (A): 99.4 mm

2. Apply a small amount of engine oil to the thread section and the washer of the cylinder head bolt.

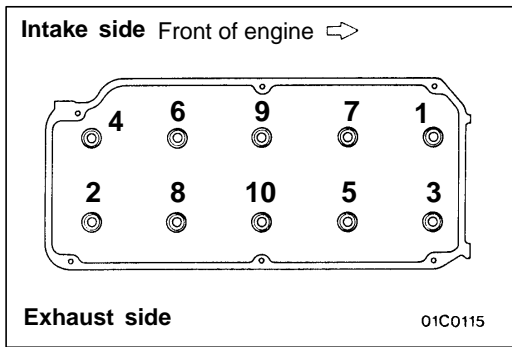

3. Tighten the bolts by the following procedure.

Step	Operation	Remarks
1	Tighten to 78 Nm.	Carry out in the order shown in the illustration.
2	Fully loosen.	Carry out in the reverse order of that shown in the illustration.
3	Tighten to 20 Nm.	Carry out in the order shown in the illustration.
4	Tighten 90° of a turn.	In the order shown in the illustration. Mark the head of the cylinder head bolt and cylinder head by paint.
5	Tighten 90° of a turn.	In the order shown in the illustration. Check that the painted mark of the head bolt is lined up with that of the cylinder head.

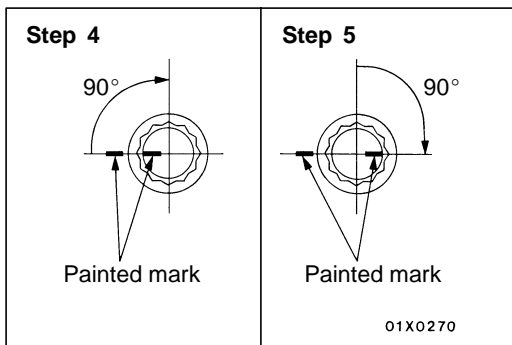

Caution

1. Always make a tightening angle just 90°. If it is less than 90°, the head bolt will be loosened.
2. If it is more than 90°, remove the head bolt and repeat the procedure from step 1.

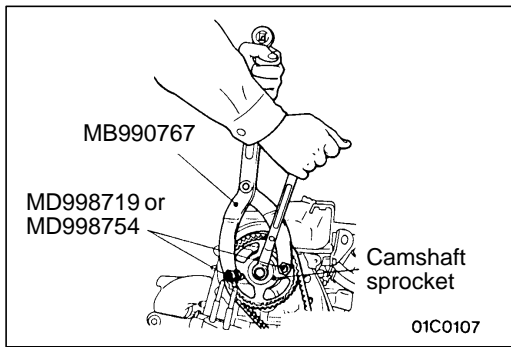
**▶C◀ CAMSHAFT SPROCKET INSTALLATION**

1. Use the special tool to stop the camshaft sprocket from turning, and then install the camshaft sprocket bolt.
2. Remove the special tool from the rubber plug hole.
3. Remove the cord which binds the camshaft sprocket and timing belt.

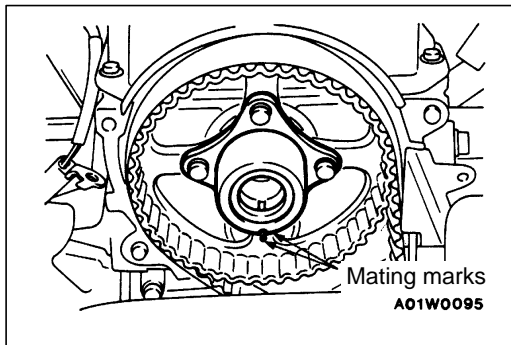
**▶D◀ CAMSHAFT SPROCKET SPACER INSTALLATION**

Align the mating marks on the camshaft sprocket and the camshaft sprocket spacer (groove), and then install them.

TIMING BELT, TIMING BELT B

REMOVAL AND INSTALLATION

Pre-removal and Post-installation Operation

- Engine Coolant Draining and Refilling (Refer to GROUP 14 – On-vehicle Service.)
- Cooling Fan Removal and Installation (Refer to GROUP 14.)
- Distributor Removal and Installation

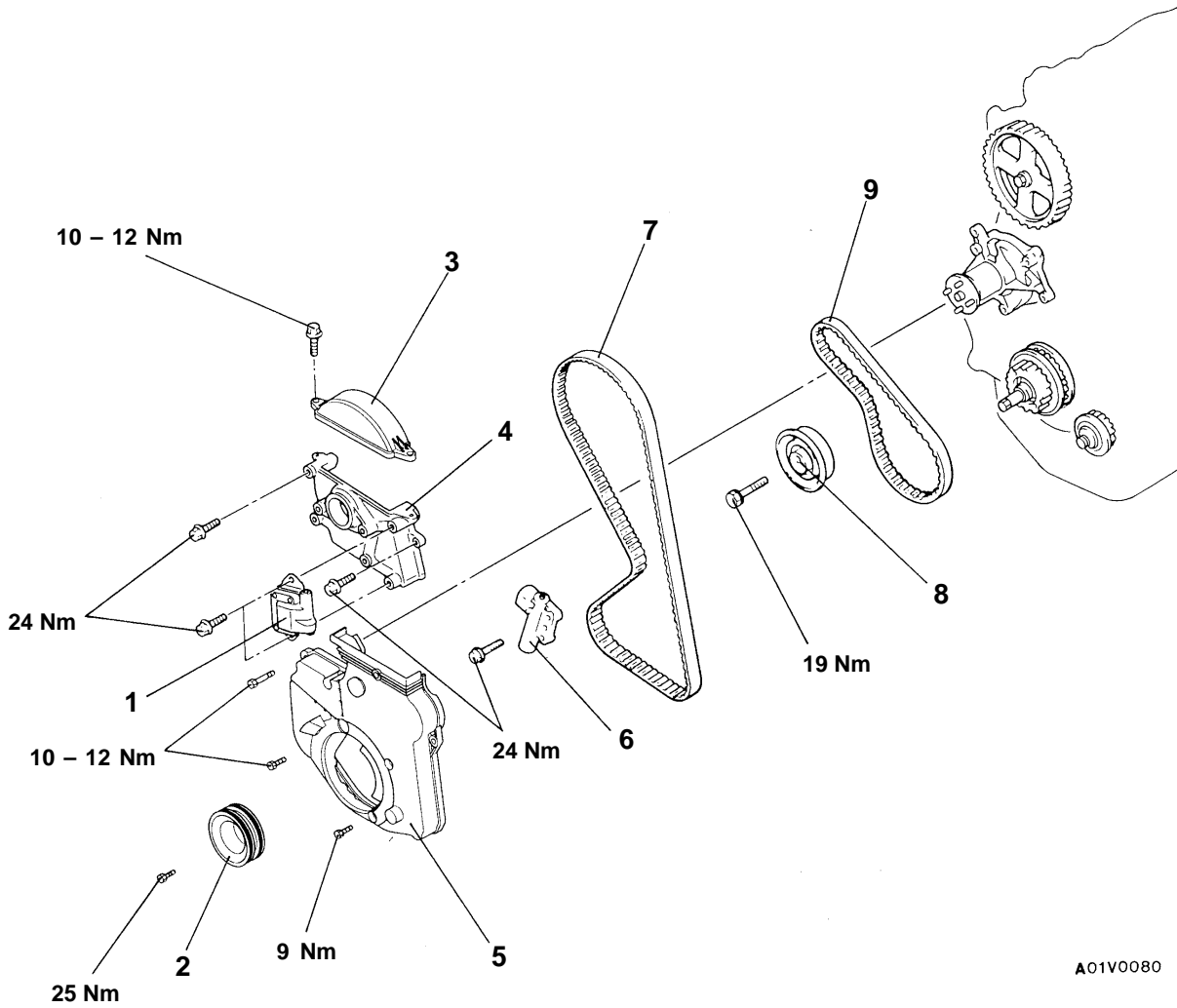

Removal steps

1. Ignition coil
 2. Crankshaft pulley
 3. Timing belt upper cover assembly
 4. Distributor bracket
 5. Timing belt lower cover assembly
- Timing belt tension adjustment

- | | | |
|-----|-----|------------------------------------|
| ◀A▶ | ▶D▶ | 6. Auto tensioner |
| ◀B▶ | ▶C▶ | 7. Timing belt |
| | ● | ● Timing belt B tension adjustment |
| | ▶B▶ | 8. Timing belt B tensioner |
| ◀B▶ | ▶A▶ | 9. Timing belt B |

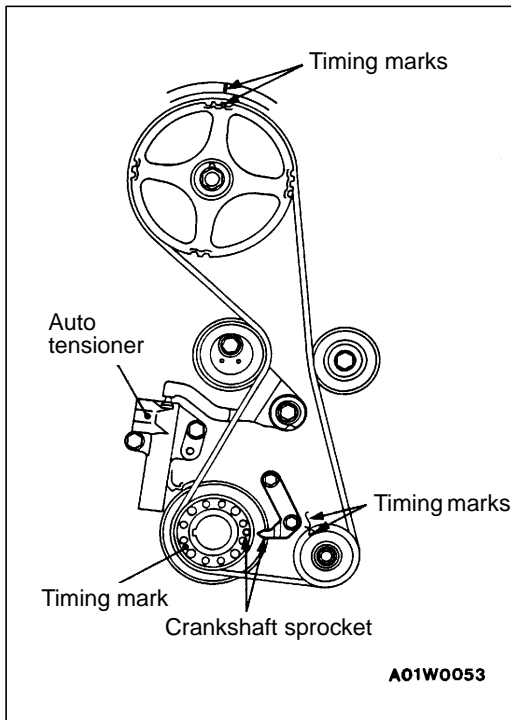
**REMOVAL SERVICE POINTS****◀A▶ AUTO TENSIONER REMOVAL**

1. Turn the crankshaft clockwise (right turn) to align each timing marks and to set the No. 1 cylinder to compression top dead centre.

Caution

Never turn the crankshaft anticlockwise.

2. Remove the auto tensioner.

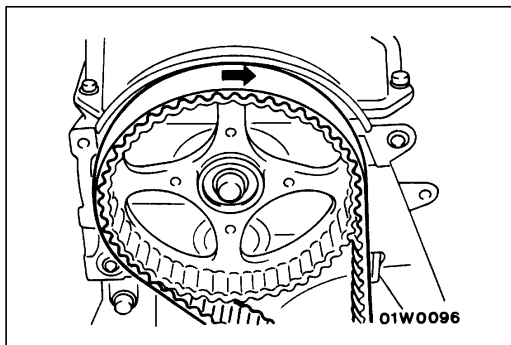
**◀B▶ TIMING BELT/TIMING BELT B REMOVAL****Caution**

If the belt is to be re-used, chalk the belt with an arrow indicating the clockwise direction of rotation.

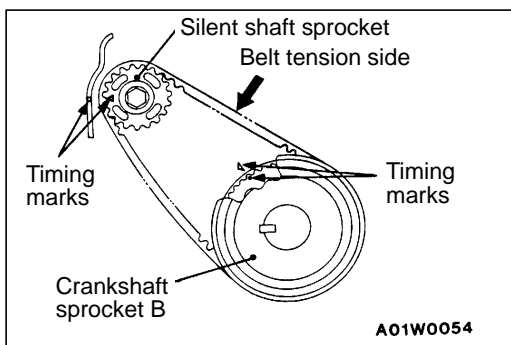
**INSTALLATION SERVICE POINTS****▶A◀ TIMING BELT B INSTALLATION**

1. Ensure that crankshaft sprocket "B" timing marks and the silent shaft sprocket timing marks are aligned.
2. Fit timing belt "B" over crankshaft sprocket B and the silent shaft sprocket. Ensure that there is no slack in the belt.

▶B◀ TIMING BELT B TENSION ADJUSTMENT

1. Temporarily fix the timing belt "B" tensioner such that the centre of the tensioner pulley is to the left and above the centre of the installation bolt, and temporarily attach the tensioner pulley so that the flange is toward the front of the engine.

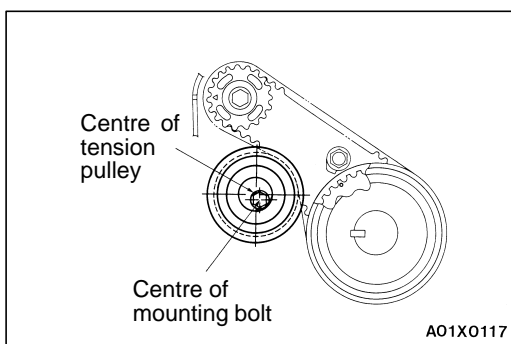

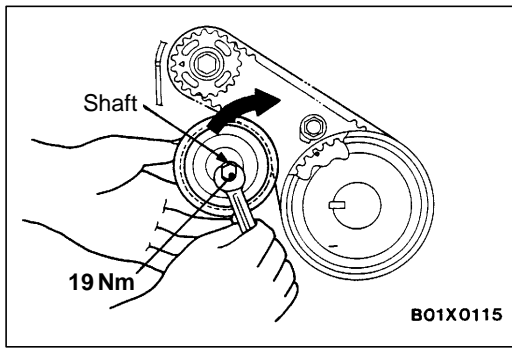

2. Holding the timing belt "B" tensioner up with your finger in the direction of the arrow, apply pressure on the timing belt so that the tension side of the belt is taut. Now tighten the bolt to fix the tensioner.

Caution

When tightening the bolt, ensure that the tensioner pulley shaft does not rotate with the bolt. Allowing it to rotate with the bolt can cause excessive tension of the belt.

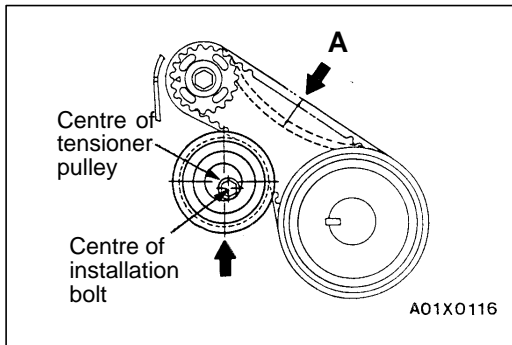

3. To ensure that the tension is correct, depress the belt (point A) with a finger. Adjust the belt tension if it is incorrect.

Standard value: 5 – 7 mm

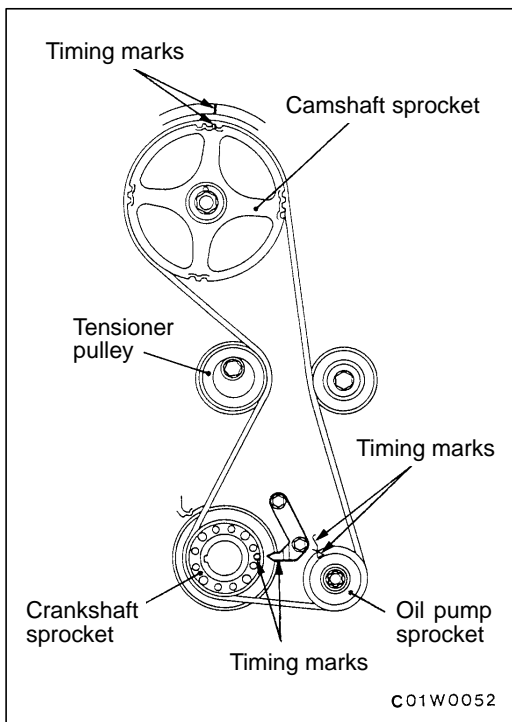

▶◀ TIMING BELT INSTALLATION

1. Check that the timing marks of the camshaft sprocket, crankshaft sprocket and oil pump sprocket are all aligned.

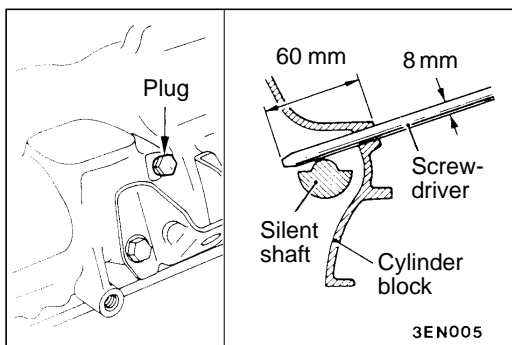

2. After aligning the timing marks on the oil pump sprocket, remove the cylinder block plug and insert a Phillips screwdriver with a diameter of 8 mm, and check to be sure that the screwdriver goes in 60 mm or more. If the screwdriver will only go in 20 – 25 mm before striking the silent shaft, turn the sprocket once, realign the timing mark and check that the screwdriver goes in 60 mm or more. The screwdriver should not be taken out until the timing belt is installed.

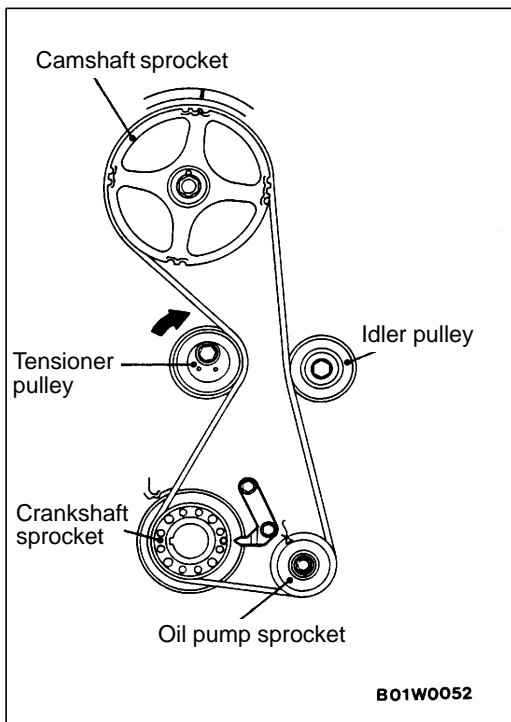

3. Install the timing belt by the following procedure.
 - (1) Place the timing belt onto the tensioner pulley and crankshaft sprocket, and hold it with your left hand so that it doesn't slip.
 - (2) While pulling the timing belt with your right hand, place it onto the oil pump sprocket.
 - (3) Place the timing belt onto the idler pulley and camshaft sprocket.
 - (4) Push the tensioner pulley in the direction shown by the arrow to apply tension to the timing belt, and then tighten the tensioner pulley fixing bolt.

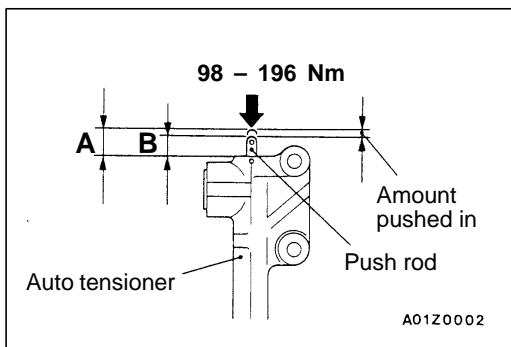

►D◄ AUTO TENSIONER INSTALLATION

1. While holding the auto-tensioner by hand, press the end of the rod against a metal surface (such as the cylinder block) with a force of 98 - 196 Nm and measure how far the rod is pushed in.

Standard value: Within 1 mm

A: Length when no force is applied

B: Length when force is applied

A - B: Amount pushed in

2. If it is not within the standard value, replace the auto tensioner.

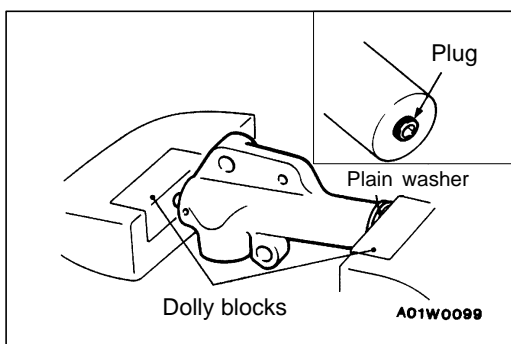

3. Place two dolly blocks in a vice as shown in the illustration, and then place the auto tensioner in the vice.

Caution

- (1) Place the auto tensioner perpendicular to the jaws of the vice.
- (2) If there is a plug at the base of the auto tensioner, insert a plain washer onto the end of the auto tensioner to protect the plug.

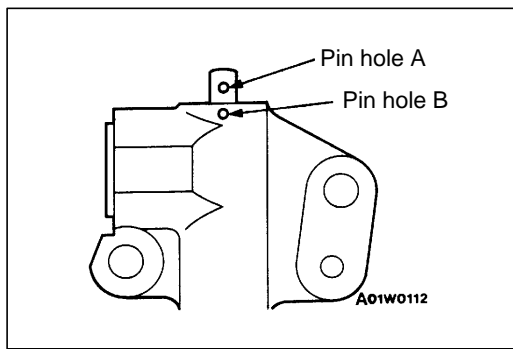

4. Slowly compress the push rod of the auto tensioner until pin hole A in the push rod is aligned with pin hole B in the cylinder.

Caution

Never compress the push rod too fast, or the push rod may be damaged.

5. Insert the setting pin into the pin holes once they are aligned.

NOTE

If replacing the auto tensioner, the pin will already be inserted into the pin holes.

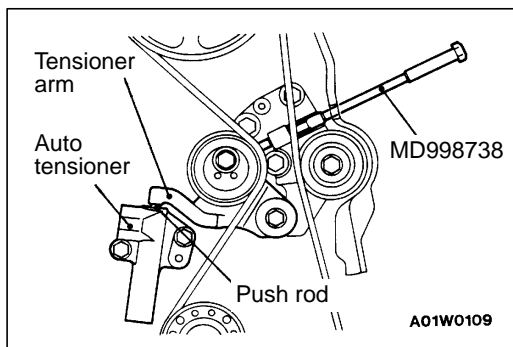

6. Install the auto tensioner to the engine.

Caution

Do not remove the setting pin from the auto tensioner.

7. Remove the rubber plug from the timing belt cover assembly rear. Then screw in the special tool by hand until the tensioner arm is touching the auto tensioner push rod.

Caution

Do not use a spanner or the similar tool to turn the special tool, otherwise, the auto tensioner setting pin may be broken. Turn the special tool by hand only.

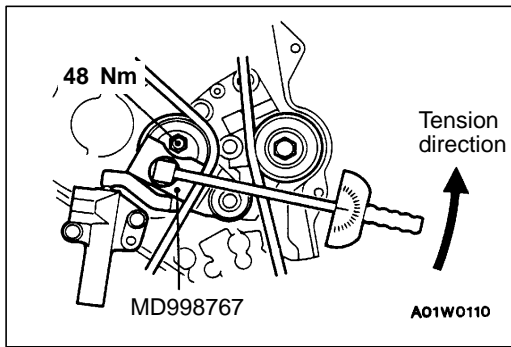

►E◄ TIMING BELT TENSION ADJUSTMENT

1. Turn the crankshaft 1/4 of a revolution in the anticlockwise direction, then turn it in the clockwise direction until the timing marks are aligned.
2. Loosen the tension pulley fixing bolt, and then use the special tool and a torque wrench to tighten the fixing bolt to the specified torque while applying tension to the timing belt.

Standard value: 3.5 Nm <Timing belt tension torque>

Caution

When tightening the fixing bolt, make sure that the tension pulley does not turn with the bolt.

3. Remove the setting pin that has been inserted into the auto tensioner, and then remove the special tool.
4. Turn the crankshaft two turns clockwise, and wait for approximately 15 minutes.

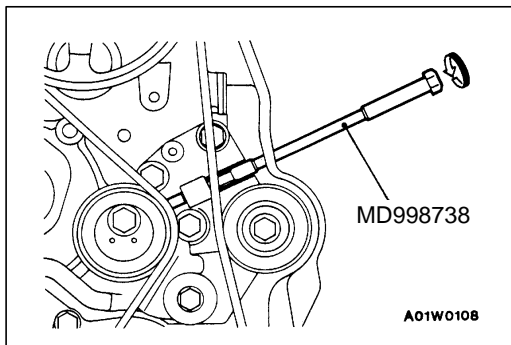

5. Insert the special tool again and turn it by hand until the end of the special tool touches the tensioner arm.

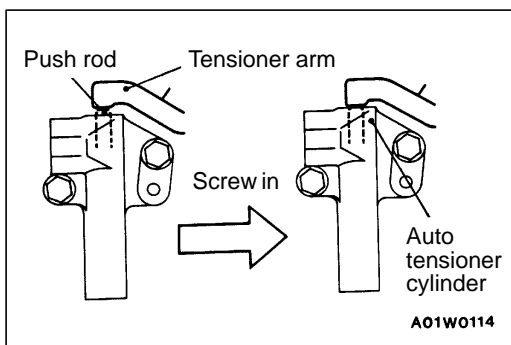

6. Once the end touches, keep turning the special tool until the auto tensioner push rod retracts and the tensioner arm contacts the auto tensioner cylinder.

Caution

Turn the special tool slowly 1/4 of a turn at a time.

7. Check that the amount by which the special tool has been screwed in is within the standard value range.

Standard value: 2.5 – 3 turns

8. Remove the special tool and install the rubber plug.

CRANKSHAFT FRONT OIL SEAL

REMOVAL AND INSTALLATION

Pre-removal and Post-installation Operation

- Timing Belt, Timing Belt B Removal and Installation (Refer to P.11A-26.)

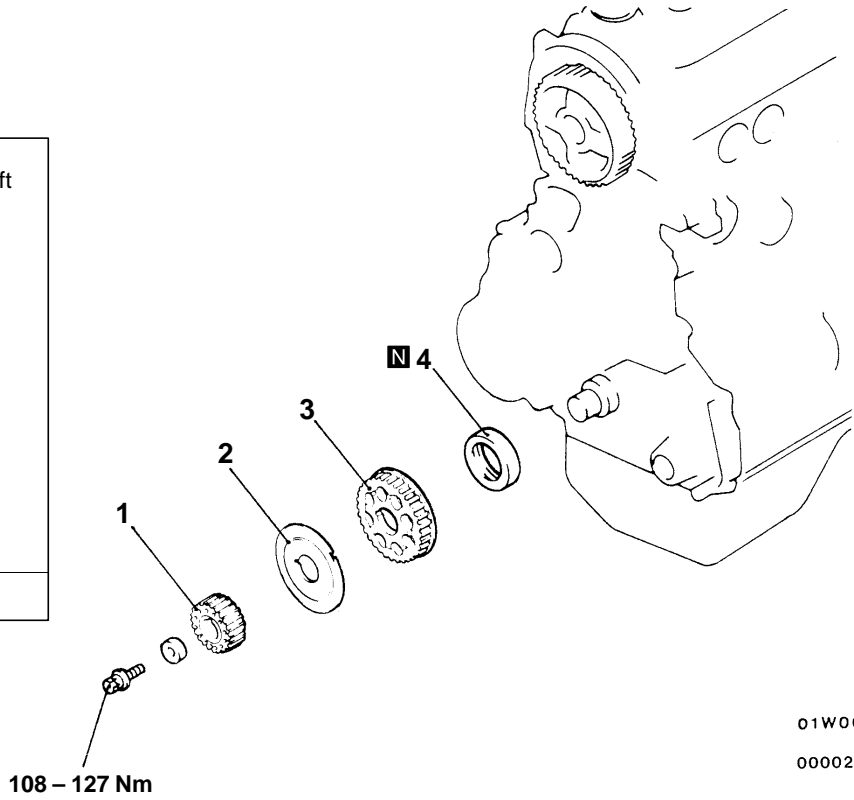
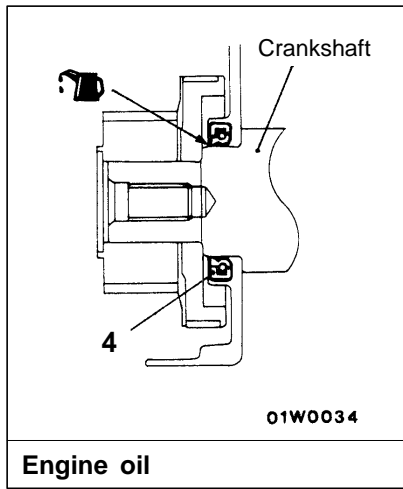

Removal steps

- ◀A▶ ▶B◀ 1. Crankshaft sprocket
- ▶B◀ ▶B◀ 2. Flange

- ▶B◀ ▶B◀ 3. Crankshaft sprocket B
- ▶B◀ ▶A◀ 4. Crankshaft front oil seal

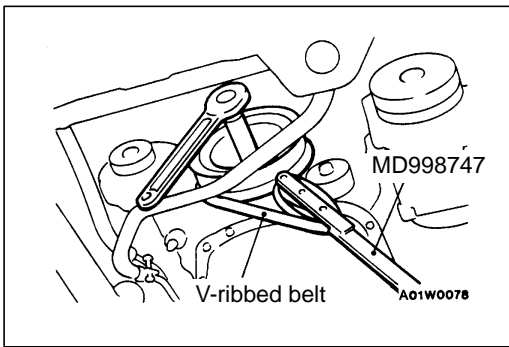
**REMOVAL SERVICE POINT****◀A▶ CRANKSHAFT SPROCKET REMOVAL**

1. Temporarily install the crankshaft pulley, and then use the V-ribbed belt and the special tool to stop the crankshaft pulley from turning.

Caution

- (1) Do not use the vehicle's V-ribbed belt, or the belt may be damaged.
- (2) Do not use a damaged V-ribbed belt.

2. Loosen the crankshaft sprocket bolt, and then remove the sprocket.

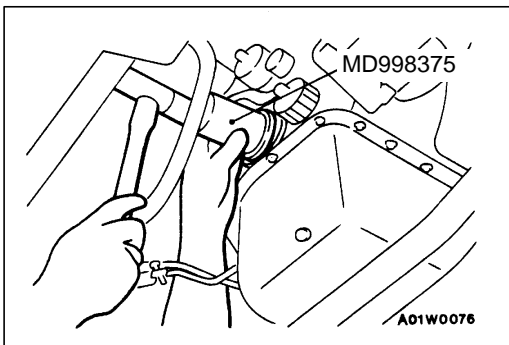
**INSTALLATION SERVICE POINTS****▶A◀ CRANKSHAFT FRONT OIL SEAL INSTALLATION**

1. Apply engine oil to the entire circumference of the oil seal lip.
2. Press-fit the oil seal until it is flush with the front case.

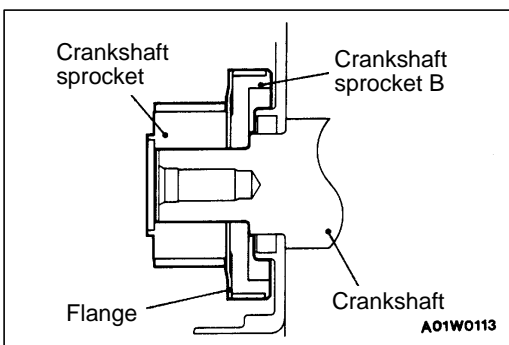
**▶B◀ CRANKSHAFT SPROCKET B/FLANGE/CRANKSHAFT SPROCKET INSTALLATION**

1. Install the crankshaft sprocket B, flange and the crankshaft sprocket so that they face as shown in the illustration.

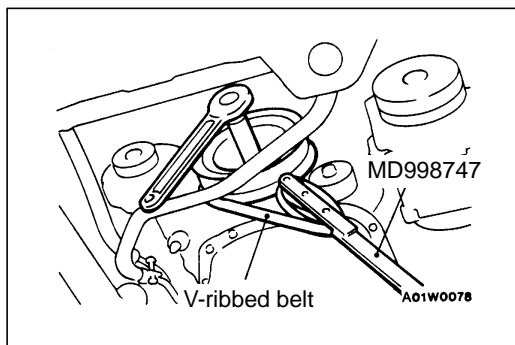

2. Temporarily install the crankshaft pulley, and then use the V-ribbed belt and the special tool to stop the crankshaft pulley from turning.

Caution

- (1) Do not use the vehicle's V-ribbed belt, or the belt may be damaged.
 - (2) Do not use a damaged V-ribbed belt.
3. Tighten the crankshaft sprocket bolt to the specified torque.

Tightening torque: 108 – 127 Nm

CRANKSHAFT REAR OIL SEAL

REMOVAL AND INSTALLATION

Pre-removal and Post-installation Operation

- Transmission Assembly Removal and Installation <2WD> (Refer to GROUP 22, 23.)
- Transmission and Transfer Assembly Removal and Installation <4WD> (Refer to GROUP 22.)

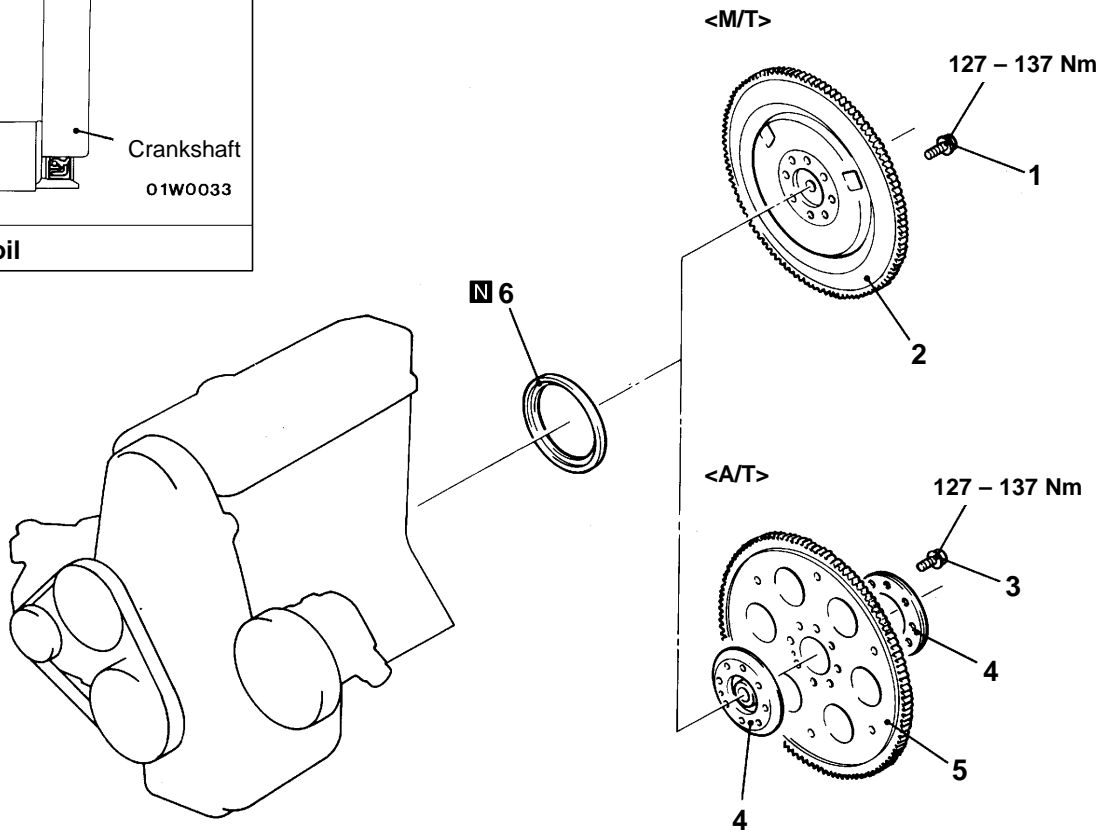
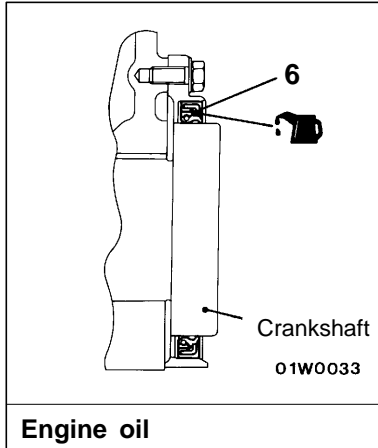

01W0036
00000854

Removal steps <M/T>

- Clutch cover and clutch disc
- ◀A▶ ▶B▶ 1. Flywheel bolt
- ▶A▶ 2. Flywheel
- ▶A▶ 6. Crankshaft rear oil seal

<A/T>

- ◀A▶ ▶B▶ 3. Drive plate bolt
- ▶A▶ 4. Adaptor plate
- ▶A▶ 5. Drive plate
- ▶A▶ 6. Crankshaft rear oil seal

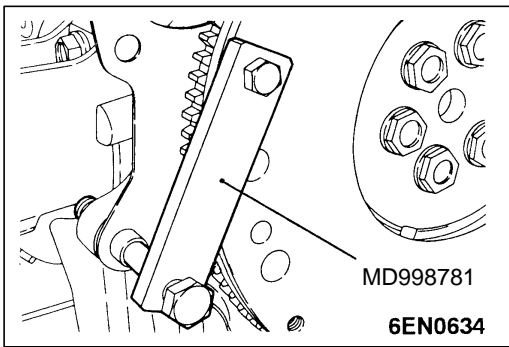
**REMOVAL SERVICE POINT**

◀A▶ FLYWHEEL BOLT <M/T>/DRIVE PLATE BOLT
<A/T> REMOVAL

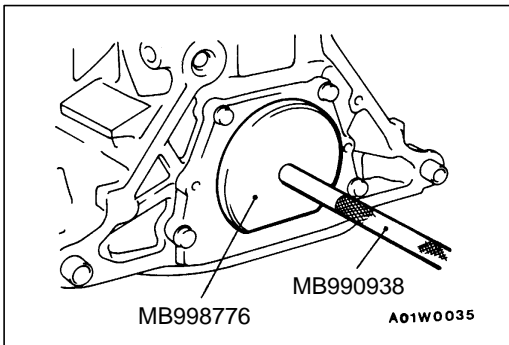
**INSTALLATION SERVICE POINTS**

▶A▶ CRANKSHAFT REAR OIL SEAL INSTALLATION

1. Apply a small amount of engine oil to the entire circumference of the oil seal lip.
2. Tap in the oil seal as shown in the illustration.

▶B▶ DRIVE PLATE BOLT <A/T>/FLYWHEEL BOLT
<M/T> INSTALLATION

Use the special tool to install the drive bolt and flywheel bolt.

ENGINE ASSEMBLY

REMOVAL AND INSTALLATION

Pre-removal Operation

- Hood Removal (Refer to GROUP 42.)
- Fuel Line Pressure Releasing (Refer to GROUP 13A – On-vehicle Service.)
- Air Cleaner and Air Intake Hose Removal (Refer to GROUP 15.)
- Battery Removal
- Radiator Removal (Refer to GROUP 14.)
- Transmission Assembly Removal <2WD> (Refer to GROUP 22, 23.)
- Transmission and Transfer Assembly Removal <4WD> (Refer to GROUP 22.)

Post-installation Operation

- Transmission and Transfer Assembly Installation <4WD> (Refer to GROUP 22.)
- Transmission Assembly Installation <2WD> (Refer to GROUP 22, 23.)
- Radiator Installation (Refer to GROUP 14.)
- Battery Installation
- Air Cleaner and Air Intake Hose installation (Refer to GROUP 15.)
- Hood Installation (Refer to GROUP 42.)
- Drive Belt Tension Adjustment (Refer to P. 11A-7.)
- Accelerator Cable Adjustment (Refer to GROUP 17 – On-vehicle Service.)
- Throttle Cable Adjustment <A/T> (Refer to GROUP 23 – On-vehicle Service.)

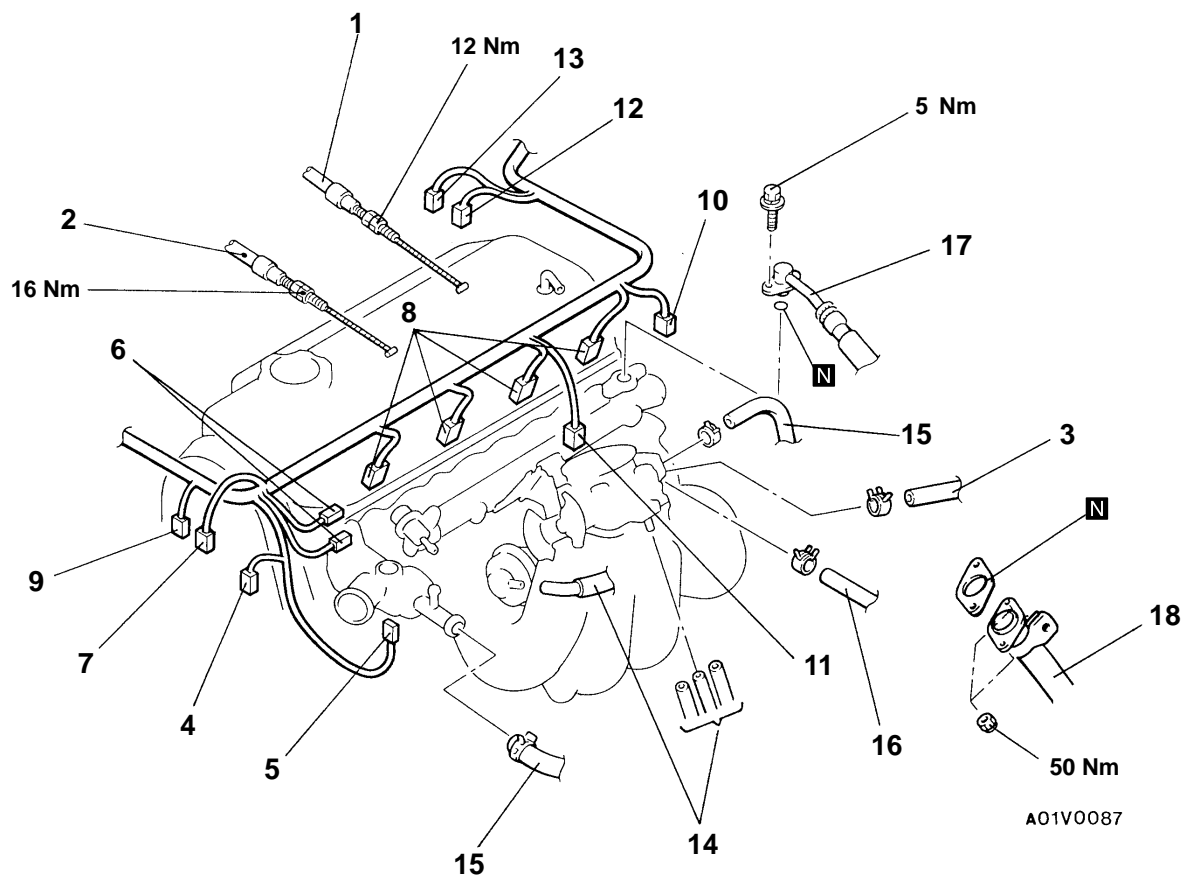
**Removal steps**

1. Accelerator cable connection
2. Throttle cable connection <A/T>
3. Brake booster vacuum connection
4. Ignition coil connector
5. Engine coolant temperature sensor connector
6. Noise filter connector
7. Power transistor connector
8. Injector connectors
9. Capacitor connector
10. Throttle position sensor connector
11. Idle speed control servo connector
12. Engine coolant temperature gauge unit connector
13. Engine coolant temperature switch connector <A/T>
14. Vacuum hose connection
15. Water hose connections
16. Fuel return hose connection
17. High-pressure fuel hose connection
18. Front exhaust pipe connection

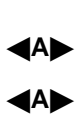
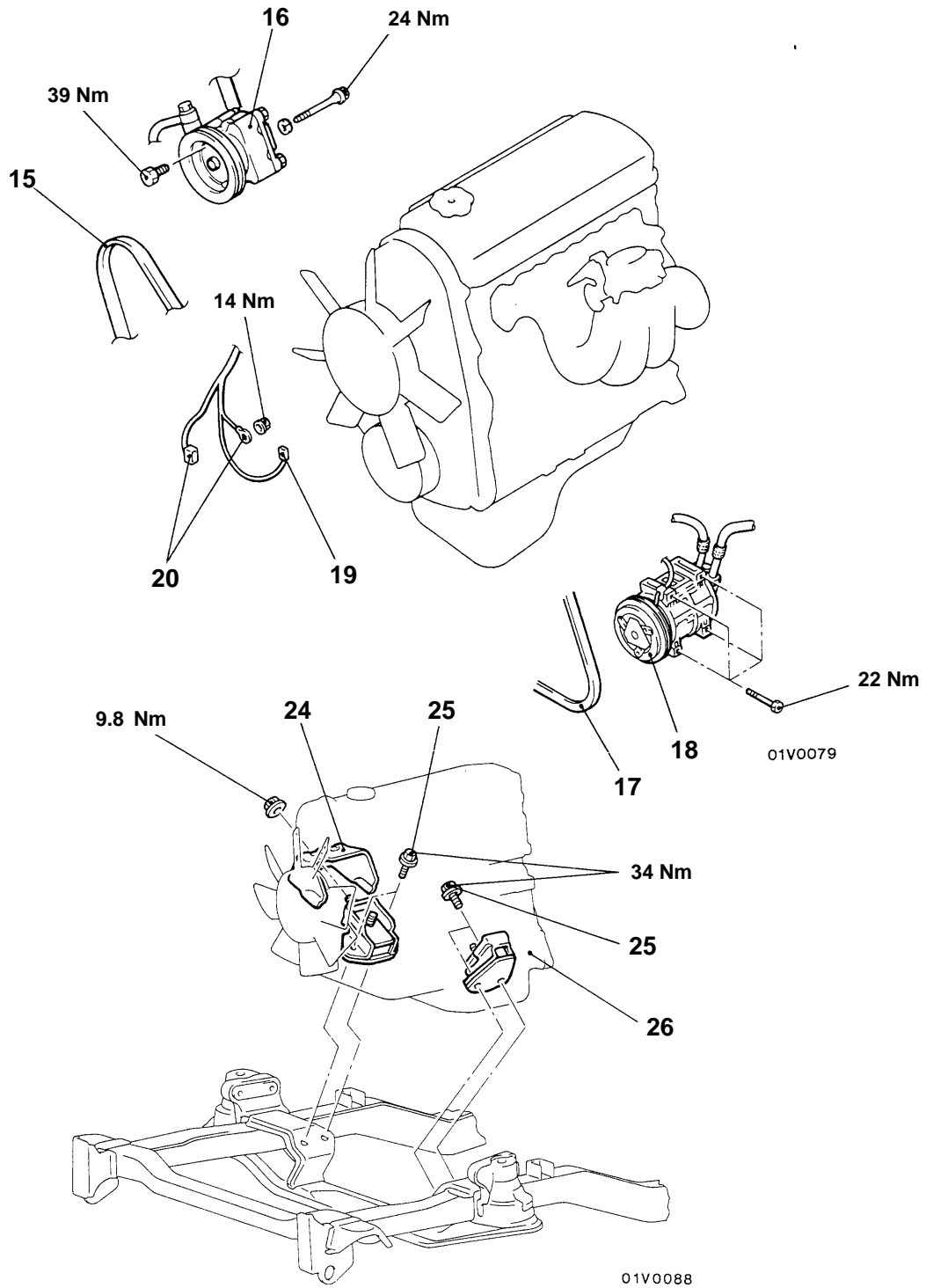

- 15. Drive belt (for Power steering)
- 16. Power steering oil pump assembly
- 17. Drive belt (for A/C)
- 18. A/C compressor assembly
- 19. Engine oil pressure switch connector



- 20. Alternator connector
- 24. Heat protector
- 25. Engine support front insulator attaching bolt
- 26. Engine assembly

REMOVAL SERVICE POINTS**◀A▶ POWER STEERING OIL PUMP ASSEMBLY AND A/C COMPRESSOR ASSEMBLY REMOVAL**

1. Remove the oil pump and A/C compressor (with the hose attached).
2. Suspend the removed oil pump (by using wire or similar material) at a place where no damage will be caused during removal/installation of the engine assembly.

◀B▶ ENGINE ASSEMBLY REMOVAL

1. Check that all cables, hoses, harness connectors, etc. are disconnected from the engine.
2. Lift the chain block slowly to remove the engine assembly upward from the engine compartment.

INSTALLATION SERVICE POINT**▶A◀ ENGINE ASSEMBLY INSTALLATION**

Install the engine assembly. When doing so, check carefully that all pipes and hoses are connected, and that none are twisted, damaged, etc.

NOTES

ENGINE <4G6>

CONTENTS

GENERAL	3	Compression Pressure Check	4
Outline of Change	3	CAMSHAFT OIL SEAL	5
SERVICE SPECIFICATIONS	3	CYLINDER HEAD GASKET	6
SPECIAL TOOLS	3	TIMING BELT AND TIMING BELT B	8
ON-VEHICLE SERVICE	4	CRANKSHAFT FRONT OIL SEAL	9
Ignition Timing Check	4		



GENERAL

OUTLINE OF CHANGE

The following procedures have been established to correspond to the change of the ignition system. Other procedures are the same as before.

SERVICE SPECIFICATIONS

Item	Standard value	Limit
Idle speed r/min	750 ± 100	–
Basic ignition timing	5° BTDC ± 2°	–
Ignition timing	Approx. 10° BTDC	–
Compression pressure (250 r/min) kPa	1,324	Min. 1,000
Compression pressure difference of all cylinder kPa	–	Max. 100

SPECIAL TOOLS

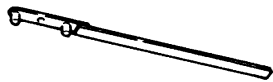
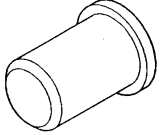
Tool	Number	Name	Use
	MD998747	Crankshaft pulley holder	Supporting of crankshaft sprocket
	MD998375	Crankshaft front oil seal installer	Press-fitting the crankshaft front oil seal

ON-VEHICLE SERVICE

IGNITION TIMING CHECK

1. Before inspection, set the vehicle to the pre-inspection condition.
2. Turn the ignition switch to “LOCK” (OFF) position and then connect the MUT-II to the diagnosis connector.
3. Set up a timing light.
4. Start the engine and run at idle.
5. Check that engine idle speed is within the standard value.

Standard value: 750 ± 100 r/min

6. Select No.17 of the MUT-II Actuator test.
7. Check that basic ignition timing is within the standard value.

Standard value: 5° BTDC ± 2°

8. If the basic ignition timing is outside the standard value, inspect the MPI system while referring to GROUP 13A – Troubleshooting.
9. Press the MUT-II clear key (Select a forced driving cancel mode) to release the Actuator test.

Caution

If the test is not cancelled, a forced driving will continue for 27 minutes. Driving under this condition may damage the engine.

10. Check that ignition timing is at the standard value.

Standard value: approx. 10° BTDC

NOTE

1. Ignition timing is variable within about ± 7°, even under normal operating.
 2. And it is automatically further advanced by about 5° from standard value at higher altitudes.
11. Remove the timing light.
 12. Turn the ignition switch to “LOCK” (OFF) position and then remove the MUT-II.

COMPRESSION PRESSURE CHECK

The following values have been changed. The service procedure is the same as before.

Compression pressure (250 r/min)

**Standard value (at engine speed of 250 r/min):
1,320 kPa**

**Limit (at engine speed of 250 r/min):
Min. 1,000 kPa**

**Compression pressure difference of all cylinder
Limit: Max. 98 kPa**

CAMSHAFT OIL SEAL

REMOVAL AND INSTALLATION

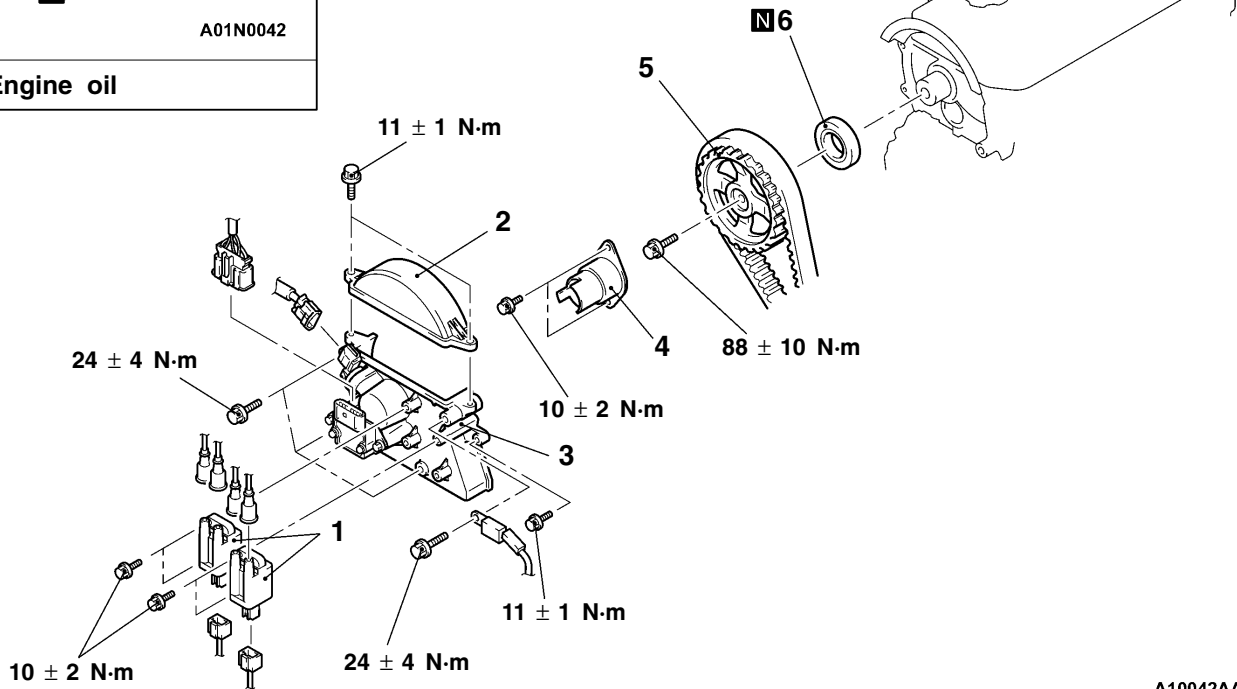
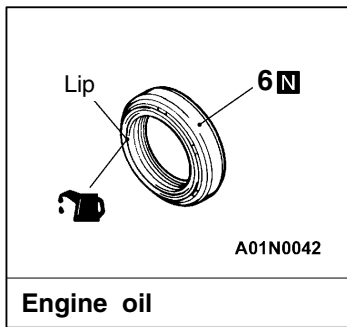

A10042AA

Removal steps

1. Ignition coil
2. Timing belt upper cover assembly
3. Ignition coil bracket, power transistor and camshaft position sensor assembly
4. Sensing cam-position cylinder
5. Camshaft sprocket



◀B▶ ▶A◀ 6. Camshaft oil seal

NOTE

Follow the conventional procedures for removal and installation service points.

CYLINDER HEAD GASKET

REMOVAL AND INSTALLATION

Pre-removal Operation

- Engine Coolant Draining
- Fuel Line Pressure Releasing
- Battery and Battery Tray Removal
- Air Cleaner Assembly Removal
- Resonance Tank Removal

Post-installation Operation

- Resonance Tank Installation
- Air Cleaner Assembly Installation
- Battery and Battery Tray Installation
- Engine Coolant Refilling
- Accelerator Cable Adjustment
- Throttle Cable Adjustment

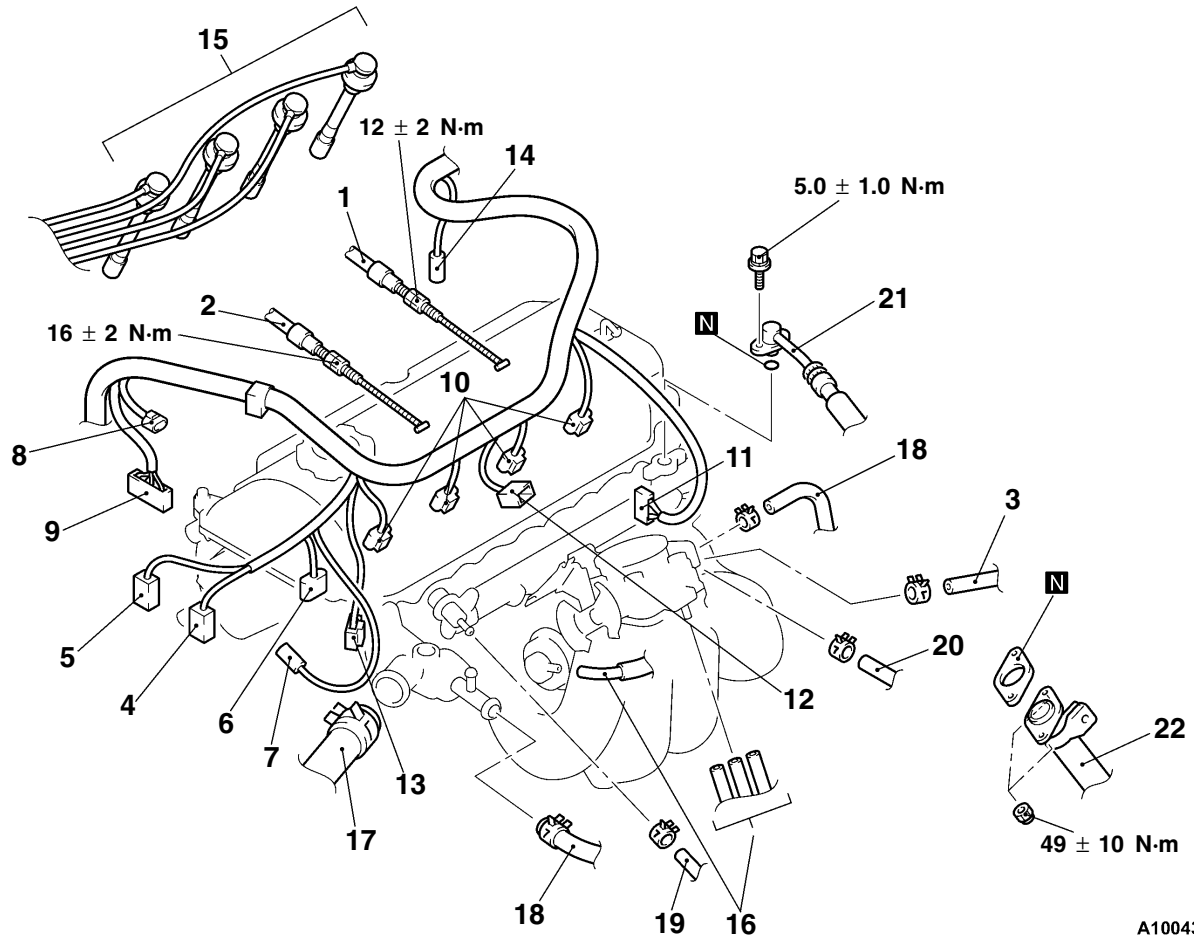

A10043AA

Removal steps

1. Accelerator cable connection
2. Throttle cable connection <A/T>
3. Brake booster vacuum hose connection
4. Ignition coil 1 connector
5. Ignition coil 2 connector
6. Engine coolant temperature sensor connector
7. Capacitor connector
8. Camshaft position sensor connector
9. Power transistor connector
10. Injector connectors
11. Throttle position sensor connector
12. Idle speed control servo connector
13. Crank angle sensor connector
14. Engine coolant temperature gauge unit connector
15. Spark plug cable
16. Vacuum hose connection
17. Radiator upper hose connection
18. Water hose connections
19. Fuel return hose connection
20. Fuel hose connection
21. High-pressure fuel hose connection
22. Front exhaust pipe connection

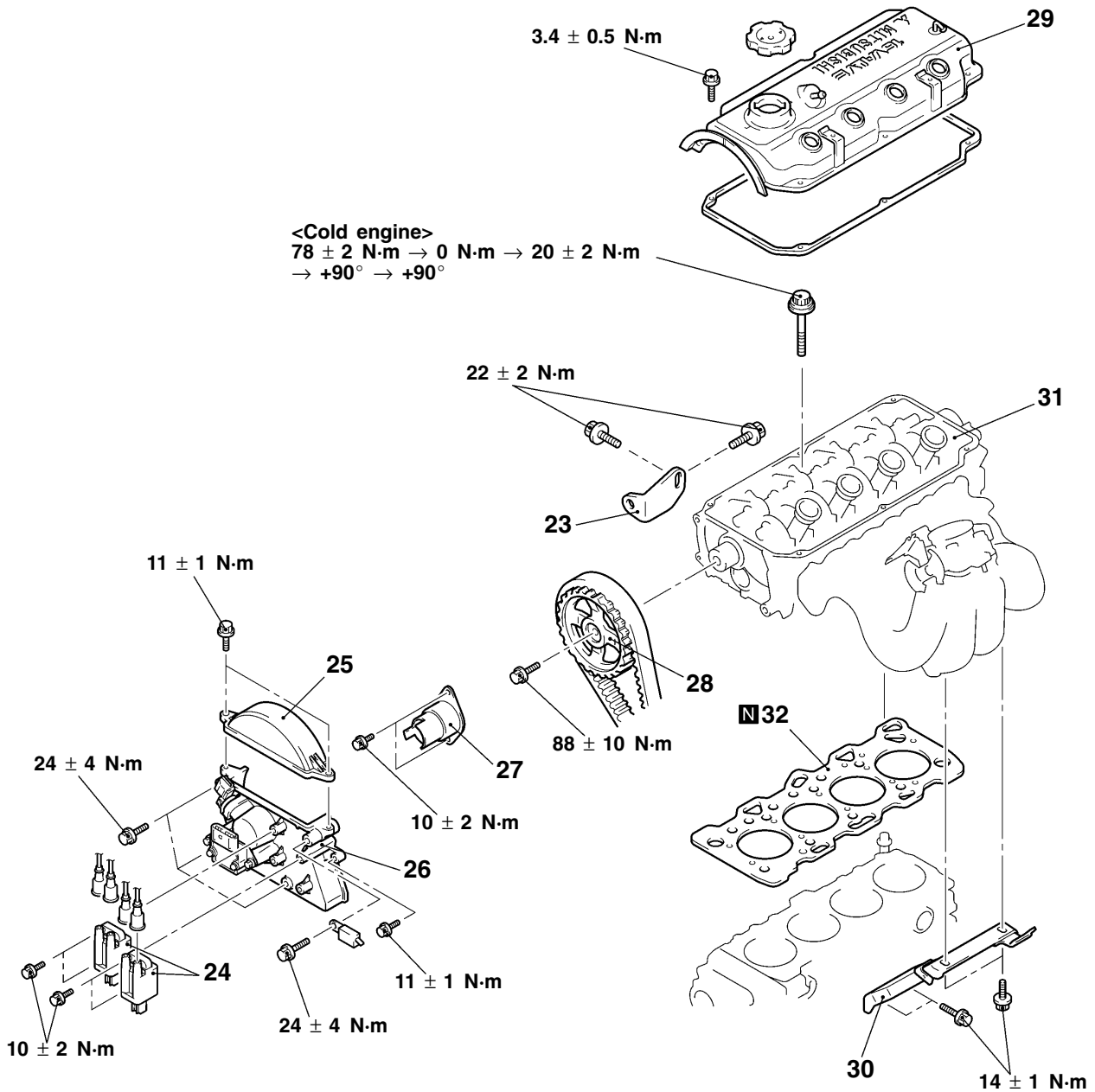

A10045AA

- 23. Power steering pump mount bracket
- 24. Ignition coil
- 25. Timing belt upper cover assembly
- 26. Ignition coil bracket, power transistor and camshaft position sensor assembly
- 27. Sensing cam-position cylinder
- 28. Camshaft sprocket

- 29. Rocker cover
- 30. Intake manifold stay
- 31. Cylinder head assembly
- 32. Cylinder head gasket

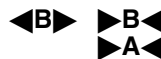

NOTE
Follow the conventional procedures for removal and installation service points.



TIMING BELT AND TIMING BELT B

REMOVAL AND INSTALLATION

Pre-removal and Post-installation Operation

- Engine Coolant Draining and Refilling
- Cooling Fan Removal and Installation

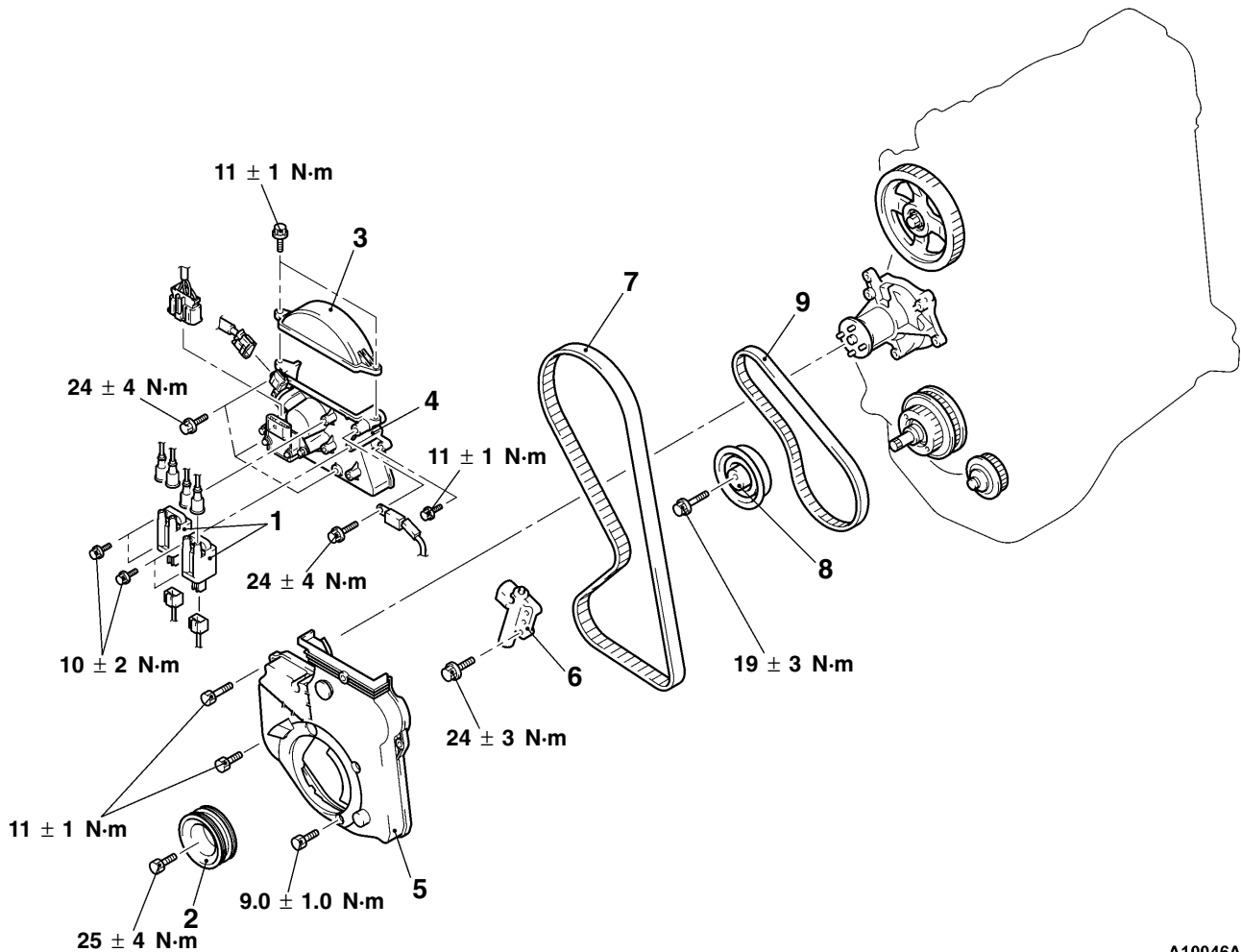

A10046AA

Removal steps

1. Ignition coil
2. Crankshaft pulley
3. Timing belt upper cover assembly
4. Ignition coil bracket, power transistor and camshaft position sensor assembly
5. Timing belt lower cover assembly
6. Auto tensioner



- ◀B▶ ▶C▶ 7. Timing belt
- ▶B▶ ● Timing belt B tension adjustment
- ▶B▶ ▶A▶ 8. Timing belt B tensioner
- ▶B▶ ▶A▶ 9. Timing belt B

NOTE

Follow the conventional procedures for removal and installation service points.

CRANKSHAFT FRONT OIL SEAL

REMOVAL AND INSTALLATION

Pre-removal and Post-installation Operation

- Timing Belt, Timing Belt B Removal and Installation (Refer to P.11A-8.)

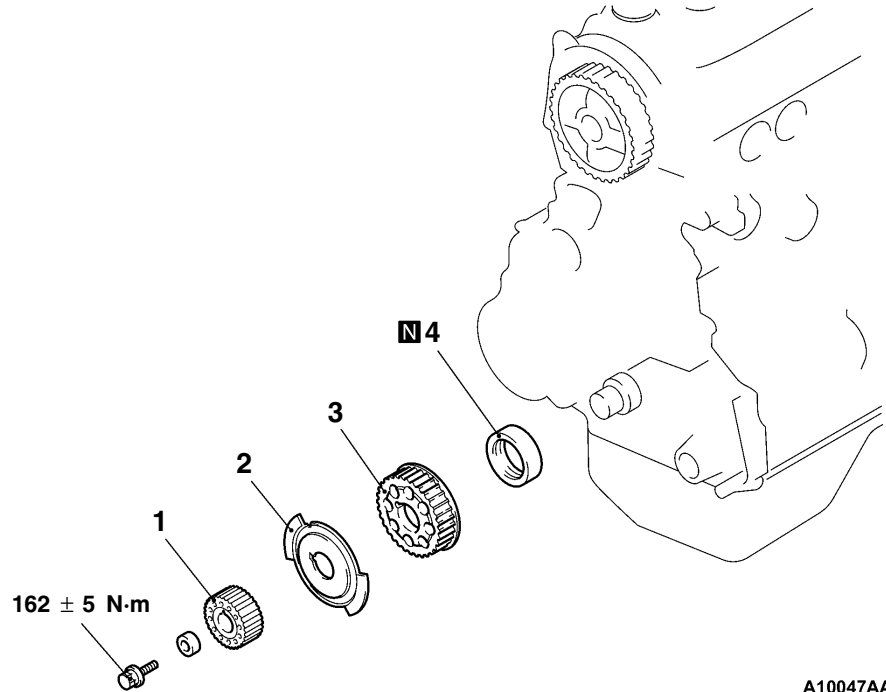
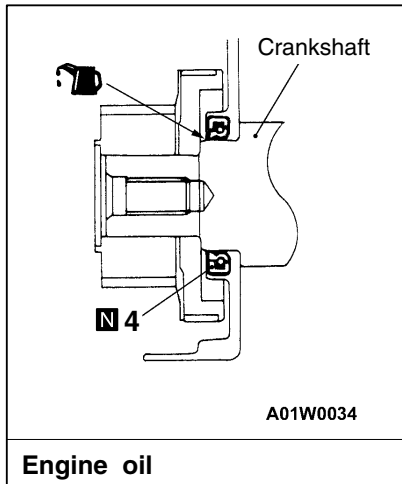

Removal steps

- ◀A▶ ▶B▶ 1. Crankshaft sprocket
▶B▶ 2. Crankshaft sensing blade

- ▶B▶ 3. Crankshaft sprocket B
▶A▶ 4. Crankshaft front oil seal

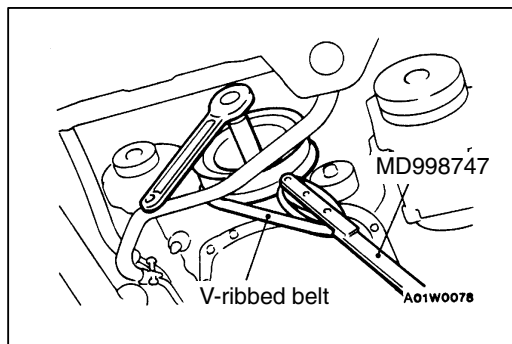

REMOVAL SERVICE POINT

◀A▶ CRANKSHAFT SPROCKET REMOVAL

1. Temporarily install the crankshaft pulley, and then use the V-ribbed belt and the special tool to stop the crankshaft pulley from turning.

Caution

- (1) Do not use the vehicle's V-ribbed belt, or the belt may be damaged.
- (2) Do not use a damaged V-ribbed belt.

2. Loosen the crankshaft sprocket bolt, and then remove the sprocket.

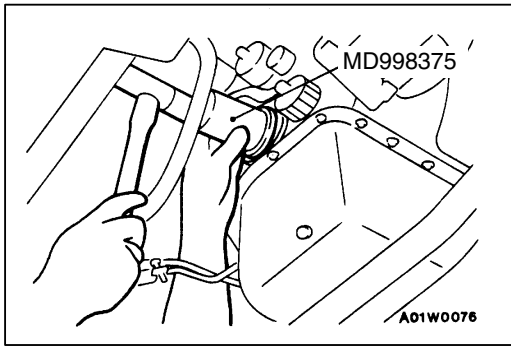

INSTALLATION SERVICE POINTS

▶A◀ CRANKSHAFT FRONT OIL SEAL INSTALLATION

1. Apply engine oil to the entire circumference of the oil seal lip.
2. Press-fit the oil seal until it is flush with the front case.

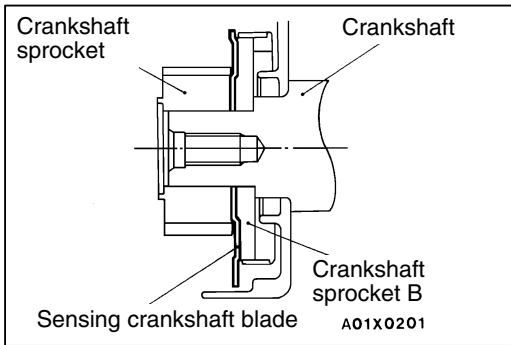

▶B◀ CRANKSHAFT SPROCKET B/CRANKSHAFT SENSING BLADE/CRANKSHAFT SPROCKET INSTALLATION

1. Install the crankshaft sprocket B, crankshaft sensing blade and the crankshaft sprocket so that they face as shown in the illustration.

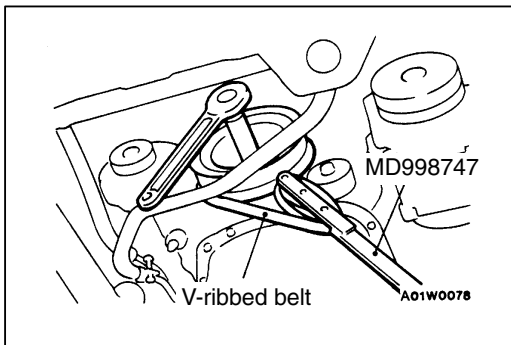

2. Temporarily install the crankshaft pulley, and then use the V-ribbed belt and the special tool to stop the crankshaft pulley from turning.

Caution

(1) Do not use the vehicle's V-ribbed belt, or the belt may be damaged.

(2) Do not use a damaged V-ribbed belt.

3. Tighten the crankshaft sprocket bolt to the specified torque.

Tightening torque: 162 ± 5 N·m