MANUAL

TRANSMISSION

F5M51

CONTENTS

GENERAL INFORMATION	22C-0-3
1. SPECIFICATIONS	22C-1-1
TRANSMISSION MODEL TABLE	22C-1-1
GEAR RATIO TABLE	22C-1-1
SERVICE SPECIFICATIONS	22C-1-1
SEALANTS AND ADHESIVES	22C-1-1
LUBRICANTS	22C-1-2
SNAP RINGS, SPACERS AND THRUST PLATE ADJUSTMENT	22C-1-3
TORQUE SPECIFICATIONS	22C-1-6
2. SPECIAL TOOLS	22C-2-1
3. TRANSMISSION	22C-3-1
4. INPUT SHAFT	22C-4-1
5. OUTPUT SHAFT	22C-5-1
6. REVERSE IDLER GEAR	22C-6-1
7. SPEEDOMETER GEAR	22C-7-1
8. SELECT LEVER	22C-8-1
9. CONTROL HOUSING	22C-9-1
10. CLUTCH HOUSING	22C-10-1
11. TRANSMISSION CASE	22C-11-1
12. DIFFERENTIAL	22C-12-1

NOTES

GENERAL INFORMATION

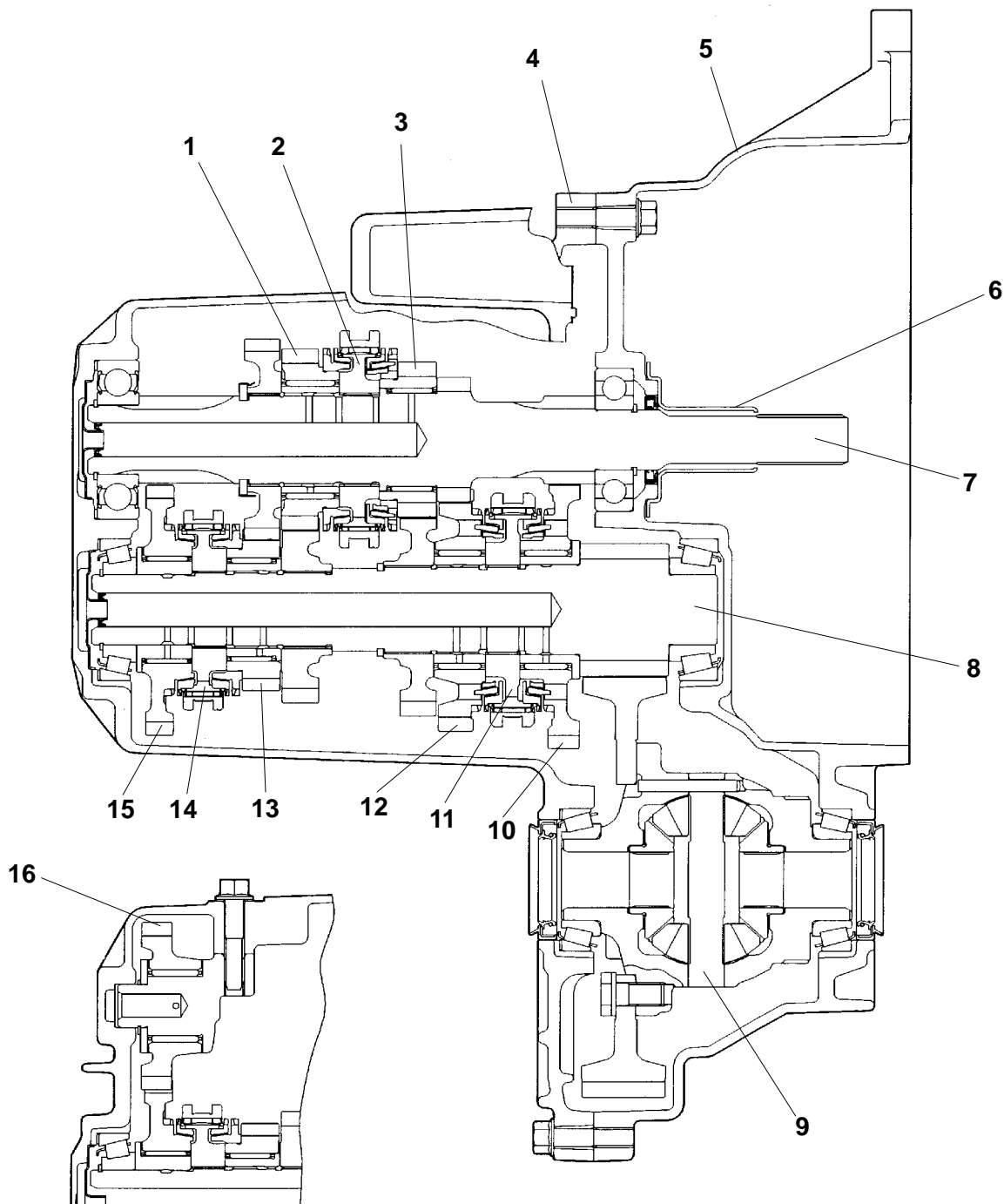

TFM0827

- 1. 4th speed gear
- 2. 3rd-4th speed synchronizer
- 3. 3rd speed gear
- 4. Transmission case
- 5. Clutch housing
- 6. Release bearing retainer
- 7. Input shaft
- 8. Output shaft

- 9. Differential
- 10. 1st speed gear
- 11. 1st-2nd speed synchronizer
- 12. 2nd speed gear
- 13. 5th speed gear
- 14. 5th-reverse speed synchronizer
- 15. Reverse gear
- 16. Reverse idler gear

1. SPECIFICATIONS

TRANSMISSION MODEL TABLE - MODEL 1997, 1998

Transmission model		Gear ratio	Speedometer gear ratio	Final gear ratio	Vehicle model	Engine model
EXP	F5M51-1-F5N	A	28/31	3.736	F36A	6G72

GEAR RATIO TABLE

	A
1st	3.583
2nd	2.105
3rd	1.407
4th	1.031
5th	0.804
Reverse	3.416

SERVICE SPECIFICATIONS

Items	Allowable range	Limit
Input shaft end play mm	0.05 - 0.17	-
Input shaft front bearing clearance mm	-0.01 - 0.12	-
Input shaft rear bearing clearance mm	-0.01 - 0.12	-
Input shaft 5th speed gear clearance mm	-0.01 - 0.09	-
Output shaft preload mm	0.13 - 0.18	-
Output shaft bearing clearance mm	-0.01 - 0.09	-
Output shaft 3rd speed gear clearance mm	-0.01 - 0.09	-
Differential case preload mm	0.05 - 0.11	-
Differential case pinion backlash mm	0.025 - 0.150	-
Synchronizer ring back surface to gear clearance mm	-	0.5

NOTE: Standard play = 0 mm

SEALANTS AND ADHESIVES

Items	Specified sealants and adhesives
Clutch housing - transmission case mating surface	MITSUBISHI genuine sealant Part No. MD997740 or equivalent
Control housing - transmission case mating surface	
Under cover - transmission case mating surface	
Air breather	3M SUPER WEATHERSTRIP No. 8001 or equivalent
Differential drive gear bolt	3M STUD Locking No. 4170 or equivalent

FORM-IN-PLACE GASKET

The transmission has several areas where the form-in-place gasket (FIPG) is in use. To ensure that the gasket fully serves its purpose, it is necessary to observe some precautions when applying the gasket. Bead size, continuity and location are of paramount importance. Too thin a bead could cause leaks. Too thick a bead, on the other hand, could be squeezed out of location, causing blocking or narrowing of the fluid feed line. To eliminate the possibility of leaks from a joint, therefore, it is absolutely necessary to apply the gasket evenly without a break, while observing the correct bead size.

Since the RTV hardens as it reacts with the moisture in the atmospheric air, it is normally used in the metallic flange areas.

DISASSEMBLY

The parts assembled with the FIPG can be easily disassembled without use of a special method. In some cases, however, the sealant between the joined surfaces may have to be broken by lightly striking with a mallet or similar tool. A flat and thin gasket scraper may be lightly hammered in between the joined surfaces. In this case, however, care must be taken to prevent damage to the joined surfaces.

SURFACE PREPARATION

Thoroughly remove all substances deposited on the gasket application surfaces, using a gasket scraper or wire brush. Check to ensure that the surfaces to which the FIPG is to be applied is flat. Make sure that there are no oils, greases and foreign substances deposited on the application surfaces. Do not forget to remove the old sealant remaining in the bolt holes.

FORM-IN-PLACE GASKET APPLICATION

When assembling parts with the FIPG, you must observe some precautions, but the procedure is very simple as in the case of a conventional pre-cut gasket.

Applied FIPG bead should be of the specified size and without breaks. Also be sure to encircle the bolt hole circumference with a completely continuous bead. The FIPG can be wiped away unless it is hardened. While the FIPG is still moist (in less than 15 minutes), mount the parts in position. When the parts are mounted, make sure that the gasket is applied to the required area only. In addition, do not apply any oil or water to the sealing locations or start the engine until a sufficient amount of time (about one hour) has passed after installation is completed.

The FIPG application procedure may vary on different areas. Observe the procedure described in the text when applying the FIPG.

LUBRICANTS

Items	Specified lubricants
Drive shaft oil seal lip area	Hypoid gear oil SAE 75W-85W conforming to API classification GL-4 or higher
Input shaft oil seal lip area	MITSUBISHI genuine grease part No. 0101011 or equivalent
Select lever shoe	

SNAP RINGS, SPACERS AND THRUST PLATE ADJUSTMENT

Part name	Thickness mm	Identification symbol	Part No.
Spacer (For adjustment of input shaft end play)	1.34	34	MD723600
	1.43	43	MD723603
	1.52	52	MD723606
	1.61	61	MD723609
	1.70	70	MD756760
	1.79	79	MD756763
Snap ring (For adjustment of input shaft front bearing clearance)	1.43	Green (2)	MD746708
	1.51	White (2)	MD746709
	1.59	Yellow (2)	MD746710
Snap ring (For adjustment of input shaft rear bearing clearance)	1.44	None	MD746602
	1.51	Blue	MD746603
	1.58	Brown	MD746604
Thrust plate (For adjustment of input shaft 5th speed gear clearance)	3.82	0	MD748465
	3.86	2	MD748466
	3.90	3	MD748467
	3.94	5	MD748468
	3.98	6	MD748469
	4.02	7	MD748470
	4.06	8	MD748471
	4.10	9	MD748472
Spacer (For adjustment of output shaft preload)	0.86	86	MD720938
	0.89	89	MD720939
	0.92	92	MD720940
	0.95	95	MD720941
	0.98	98	MD720942
	1.01	01	MD720943
	1.04	04	MD720944
	1.07	07	MD720945
	1.10	J	MD710454
	1.13	D	MD700270

Part name	Thickness mm	Identification symbol	Part No.
Spacer (For adjustment of output shaft preload)	1.16	K	MD710455
	1.19	L	MD710456
	1.22	G	MD700271
	1.25	M	MD710457
	1.28	N	MD710458
	1.31	E	MD706574
	1.34	O	MD710459
	1.37	P	MD710460
	1.40	None	MD706573
	1.43	Q	MD710461
	1.46	R	MD710462
Snap ring (For adjustment of output shaft bearing clearance)	1.36	Yellow	MD748449
	1.40	Green	MD748450
	1.44	None	MD746602
	1.48	Black	MD748451
	1.51	Blue	MD746603
	1.55	White	MD748452
	1.58	Brown	MD746604
	1.63	Orange	MD748453
	1.68	Blue	MD748454
Snap ring (For adjustment of output shaft 3rd speed gear clearance)	2.81	None	MD746594
	2.85	Blue	MD746595
	2.89	Brown	MD746596
	2.93	Yellow	MD746597
	2.97	Green	MD746598
	3.01	Black	MD746599
	3.05	White	MD746600
	3.09	Orange	MD746601
Spacer (For adjustment of differential case preload)	0.74	74	MD727660
	0.77	77	MD754476
	0.80	80	MD727661

Part name	Thickness mm	Identification symbol	Part No.
Spacer (For adjustment of differential case preload)	0.83	83	MD720937
	0.86	86	MD720938
	0.89	89	MD720939
	0.92	92	MD720940
	0.95	95	MD720941
	0.98	98	MD720942
	1.01	01	MD720943
	1.04	04	MD720944
	1.07	07	MD720945
	1.10	J	MD710454
	1.13	D	MD700270
	1.16	K	MD710455
	1.19	L	MD710456
	1.22	G	MD700271
	1.25	M	MD710457
1.28	N	MD710458	
1.31	E	MD706574	
Spacer (For adjustment of differential case pinion backlash)	0.6	-	MD748362
	0.7	-	MD748363
	0.8	-	MD748364
	0.9	-	MD748365
	1.0	-	MD748366
	1.1	-	MD748367

TORQUE SPECIFICATIONS

Items	Nm
Under cover mounting bolt	6.9
Interlock plate bolt	30
Clutch housing - transmission case mounting bolt	44
Clutch release bearing retainer mounting bolt	9.8
Control housing mounting bolt	18
Shift cable bracket mounting bolt	18
Speedometer gear mounting bolt	3.9
Stopper bracket mounting bolt	22
Select lever mounting bolt	18
Select lever mounting nut	11
Differential drive gear mounting bolt	132
Back-up lamp switch	32
Plug	32
Reverse idler gear shaft mounting bolt	48
Roll stopper bracket mounting bolt	69

2. SPECIAL TOOLS

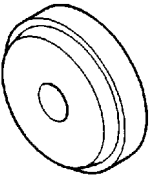
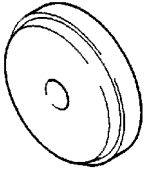
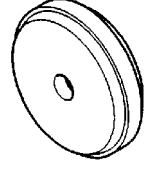
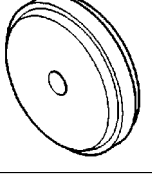
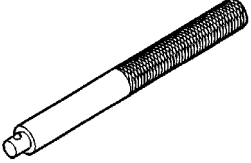
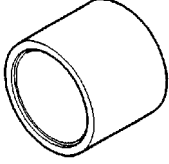
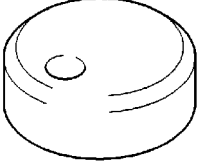
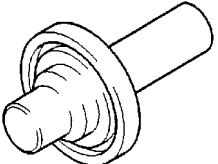
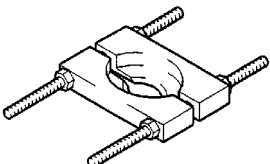
Tool	Number	Name	Use
	MB990928	Installer adapter	Installation of input shaft oil seal
	MB990932	Installer adapter	Removal of differential case taper roller bearing
	MB990935	Installer adapter	Installation of output shaft front taper roller bearing outer race
	MB990937	Installer adapter	Installation of differential case taper roller bearing
	MB990938	Handle	Use with Installer adapter
	MB991445	Bushing remover and installer base	Installation of differential case taper roller bearing outer race
	MD998364	Camshaft oil seal installer	Installation of gear, bearing and sleeve
	MD998800	Oil seal installer	Installation of differential oil seal
	MD998801	Bearing remover	Installation and removal of gear, bearing and sleeve

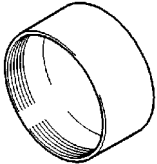
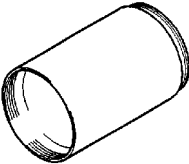
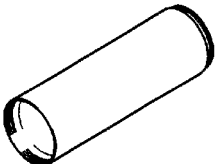
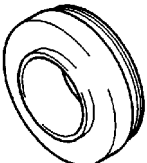
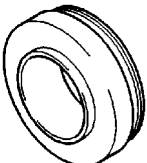
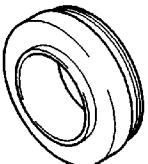
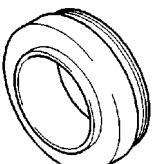
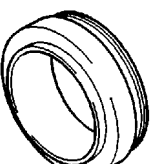
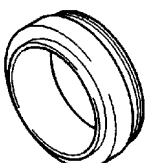
Tool	Number	Name	Use
	MD998812	Installer cap	Use with Installer and Installer adapter
	MD998813	Installer-100	Use with Installer cap and Installer adapter
	MD998814	Installer-200	Use with Installer cap and Installer adapter
	MD998818	Installer adapter (38)	Installation of input shaft front bearing
	MD998819	Installer adapter (40)	Installation of input shaft rear bearing and output shaft taper roller bearing
	MD998820	Installer adapter (42)	Installation of reverse gear bearing sleeve
	MD998821	Installer adapter (44)	Installation of 4th speed gear, 5th speed gear sleeve and 5th-reverse speed synchronizer hub
	MD998824	Installer adapter (50)	Installation of 1st-2nd speed synchronizer hub, 2nd speed gear sleeve and 3rd speed gear
	MD998825	Installer adapter (52)	Installation of 1st speed gear sleeve, 3rd-4th speed synchronizer hub, 4th speed gear sleeve, 5th speed gear and thrust plate stopper

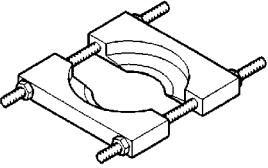
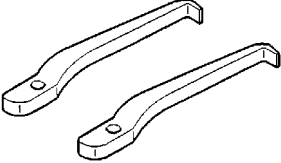
Tool	Number	Name	Use
	MD998917	Bearing remover	Removal and installation of gear, bearing and sleeve
	MD999566	Claw	Removal of taper roller bearing outer race

3. TRANSMISSION DISASSEMBLY AND REASSEMBLY

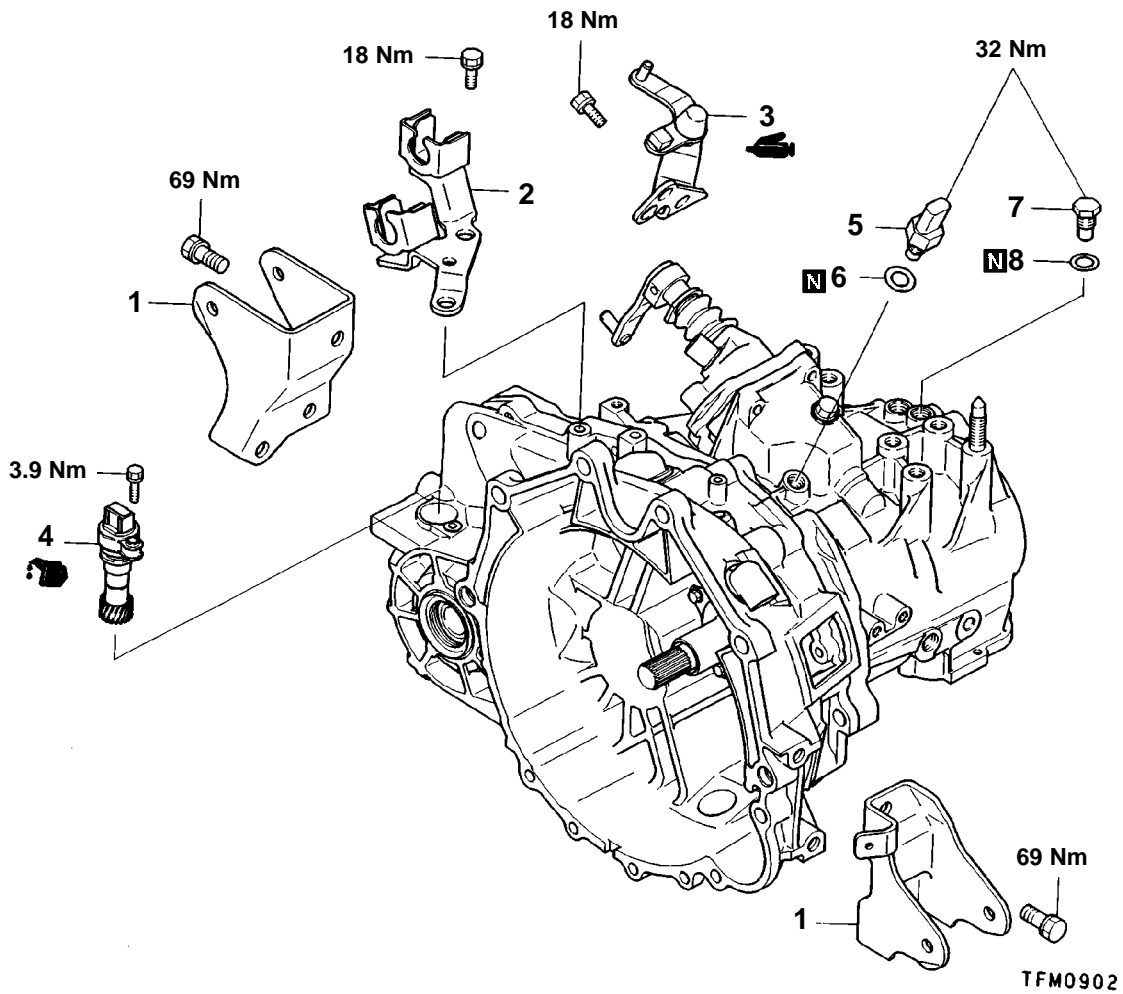

Disassembly steps



1. Roll stopper bracket
2. Shift cable bracket
3. Select lever
4. Speedometer gear
5. Back-up lamp switch
6. Gasket
7. Plug
8. Gasket

Apply gear oil to all moving parts before installation.

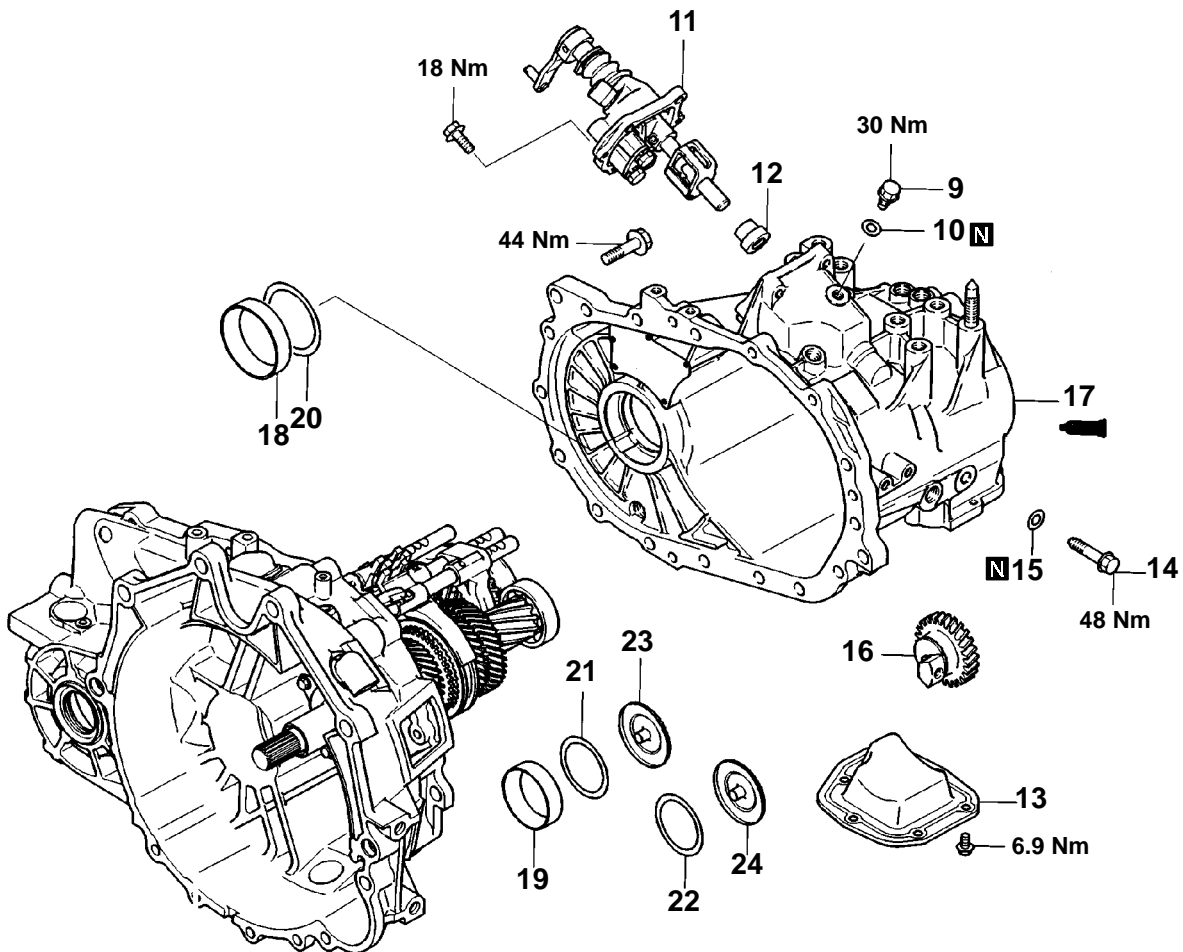

TFM0903

Disassembly steps

- | | | | |
|-----|-----------------------------------|-----|-----------------------|
| | 9. Interlock plate bolt | | 17. Transmission case |
| | 10. Gasket | ▶G◀ | 18. Outer race |
| ▶I◀ | 11. Control housing | | 19. Outer race |
| | 12. Neutral return spring | ▶F◀ | 20. Spacer |
| ▶H◀ | 13. Under cover | ▶F◀ | 21. Spacer |
| | 14. Reverse idler gear shaft bolt | ▶F◀ | 22. Spacer |
| | 15. Gasket | | 23. Oil guide |
| | 16. Reverse idler gear | | 24. Oil guide |

Apply gear oil to all moving parts before installation.

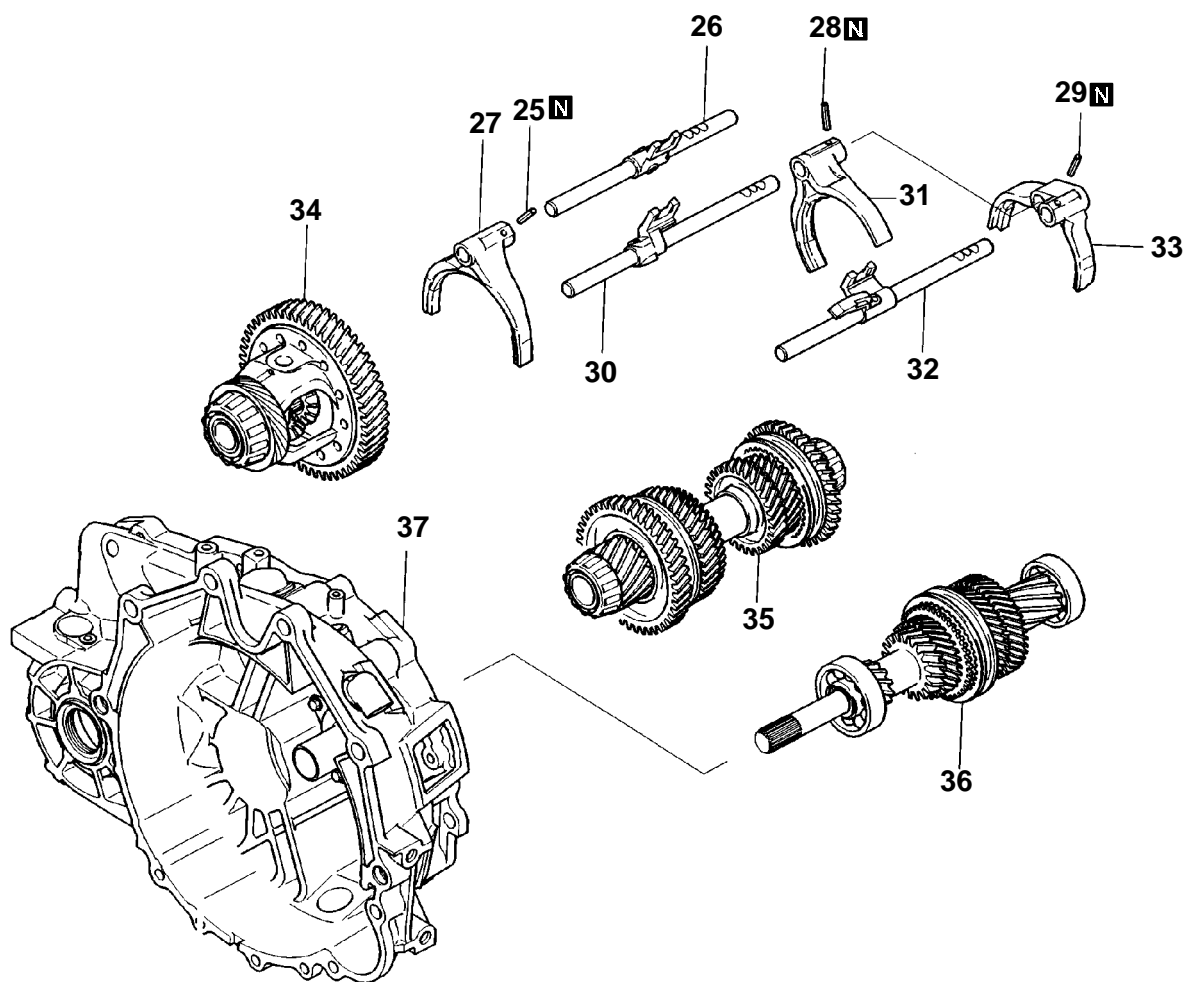

TFM0904

Disassembly steps

- ▶E◀ 25. Spring pin
- ▶E◀ 26. 1st-2nd speed shift rail
- ▶E◀ 27. 1st-2nd speed shift fork
- ▶D◀ 28. Spring pin
- ▶C◀ 29. Spring pin
- ▶B◀ 30. 3rd-4th speed shift rail
- ▶B◀ 31. 3rd-4th speed shift fork
- ▶B◀ 32. 5th-reverse speed shift rail
- ▶B◀ 33. 5th-reverse speed shift fork
- ▶C◀ 34. Differential
- ▶A◀ 35. Output shaft
- ▶C◀ 36. Input shaft
- ▶A◀ 37. Clutch housing

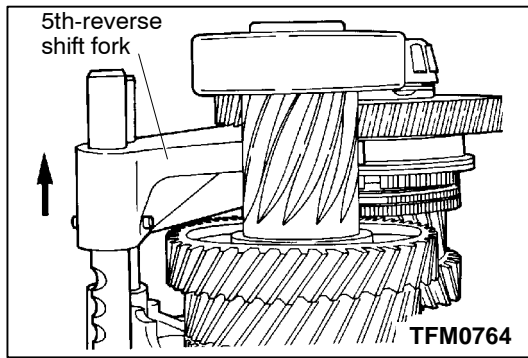
**DISASSEMBLY SERVICE POINTS****◀A▶ SPRING PIN REMOVAL**

Shift the 5th-reverse shift fork in the direction shown in the illustration.

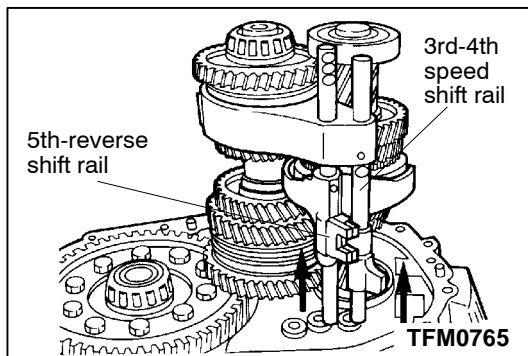
**◀B▶ 3RD-4TH SPEED SHIFT RAIL / 3RD-4TH SPEED SHIFT FORK / 5TH-REVERSE SPEED SHIFT RAIL / 5TH-REVERSE SPEED SHIFT FORK REMOVAL**

Pull out the shift rails from the shift rail holes in the clutch housing.

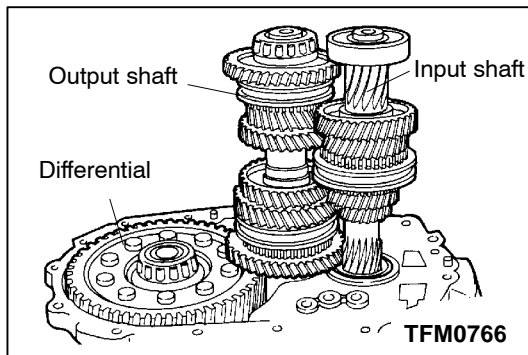
**◀C▶ DIFFERENTIAL / OUTPUT SHAFT / INPUT SHAFT REMOVAL**

Remove the input shaft, output shaft and differential together.

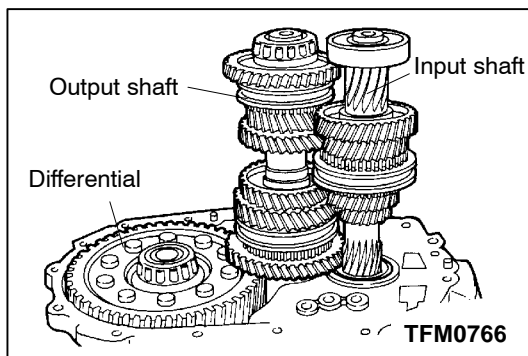
**ADJUSTMENT BEFORE REASSEMBLY****SPACER SELECTION FOR ADJUSTING INPUT SHAFT END PLAY / OUTPUT SHAFT PRELOAD / DIFFERENTIAL PRELOAD**

(1) Install the input shaft, output shaft and differential as a set to the clutch housing.

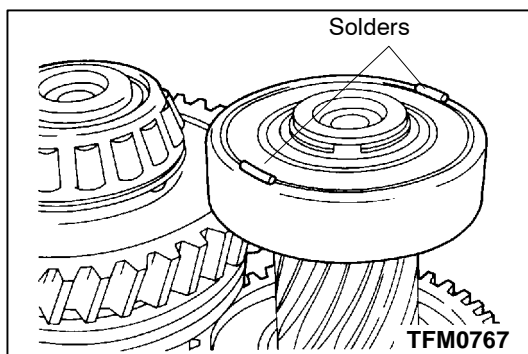

(2) Place two pieces of solder (1.6 mm in diameter and approx. 10 mm in length) on the input shaft rear bearing at the positions shown in the illustration.

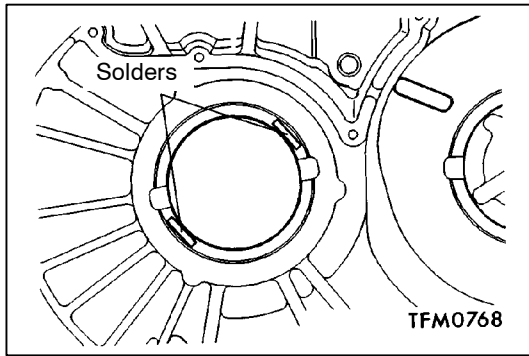

- (3) Place two pieces of solder (1.6 mm in diameter and approx. 10 mm in length) on the transmission case at the positions shown in the illustration.
- (4) Install the bearing outer race.
- (5) Install the transmission case and tighten the bolts to the specified torque.

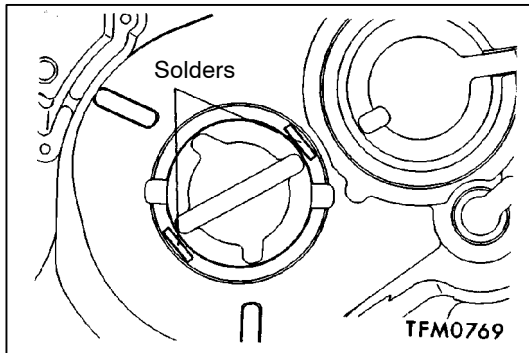

- (6) Remove the transmission case. If the solder is not crushed, repeat the steps (2) through (5) using the solder with larger diameter.

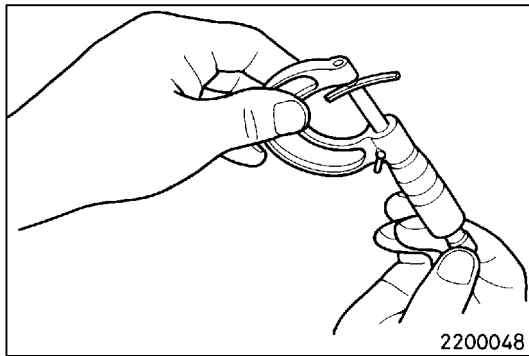

- (7) Measure the thickness of the crushed solder with a micrometer and select spacers that will provide the standard end play/preload value.

Standard value:

Input shaft end play	0.05 - 0.17 mm
Output shaft end play	0.13 - 0.18 mm
Differential preload	0.05 - 0.11 mm

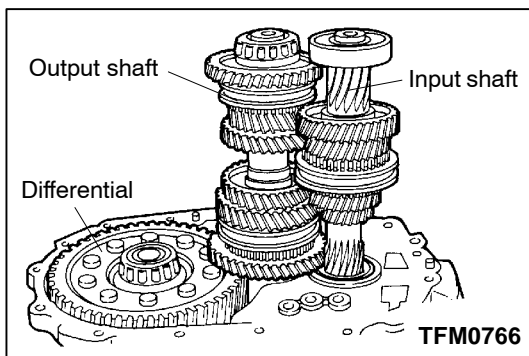

REASSEMBLY SERVICE POINTS

▶A◀ INPUT SHAFT / OUTPUT SHAFT / DIFFERENTIAL INSTALLATION

- (1) Install the input shaft, output shaft and differential as a unit.

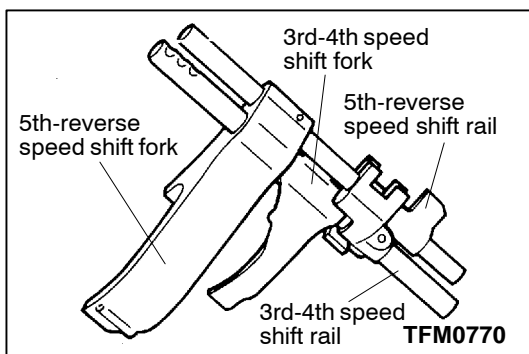

▶B◀ 5TH-REVERSE SPEED SHIFT FORK / 5TH-REVERSE SPEED SHIFT RAIL / 3RD-4TH SPEED SHIFT RAIL INSTALLATION

- (1) Install the 3rd-4th speed shift rails and fork, and 5th-reverse speed shift rail and fork.

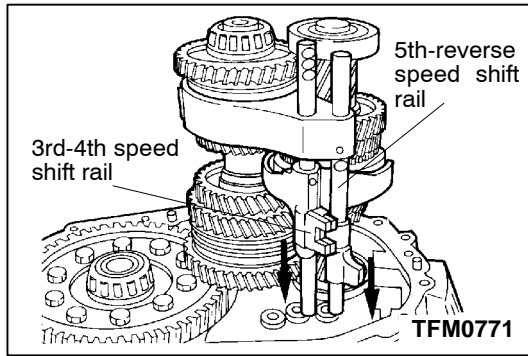

- (2) Slide the shift rails into the shift rail holes in the clutch housing.

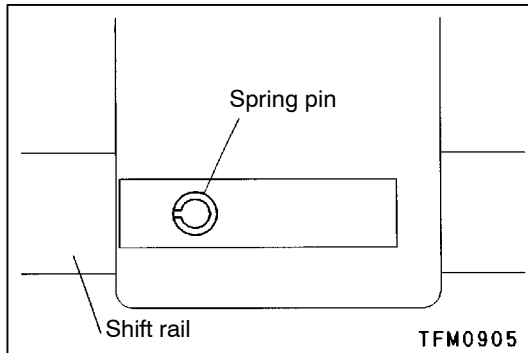

►C◄ SPRING PIN INSTALLATION

Install the spring pin with its slit directed as shown in the illustration.

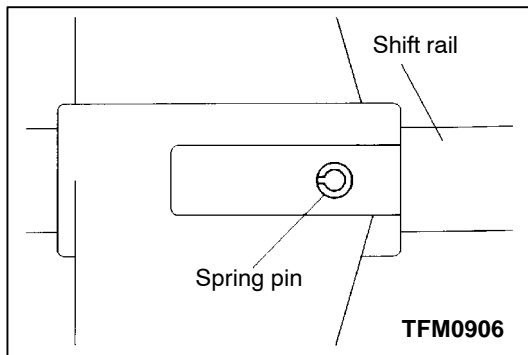

►D◄ SPRING PIN INSTALLATION

Install the spring pin with its slit directed as shown in the illustration.

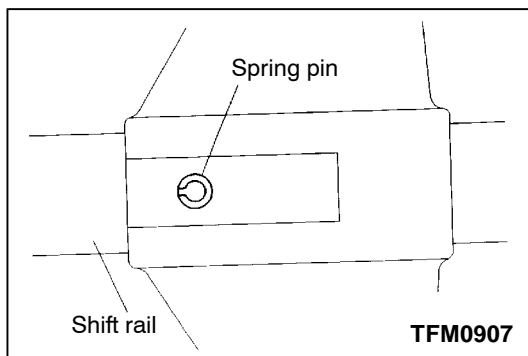

►E◄ SPRING PIN INSTALLATION

Install the spring pin with its slit directed as shown in the illustration.

►F◄ SPACER INSTALLATION

Install the spacer selected in the section "ADJUSTMENT BEFORE REASSEMBLY".

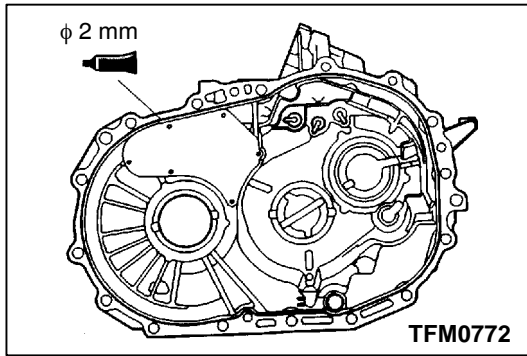

►G◄ TRANSMISSION CASE INSTALLATION

Apply sealant to the illustrated position of the transmission case.

Specified sealant:
MITSUBISHI genuine sealant part No. MD997740 or equivalent

Caution
 Squeeze out the sealant uniformly, while making sure that it is not broken or excessively applied.

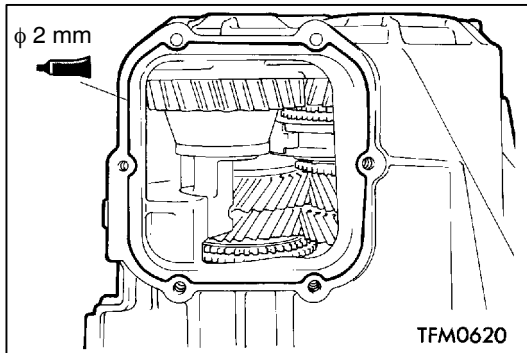

►H◄ UNDER COVER INSTALLATION

Apply sealant to the illustrated position of the transmission case.

Specified sealant:
MITSUBISHI genuine sealant part No. MD997740 or equivalent

Caution
 Squeeze out the sealant uniformly, while making sure that it is not broken or excessively applied.

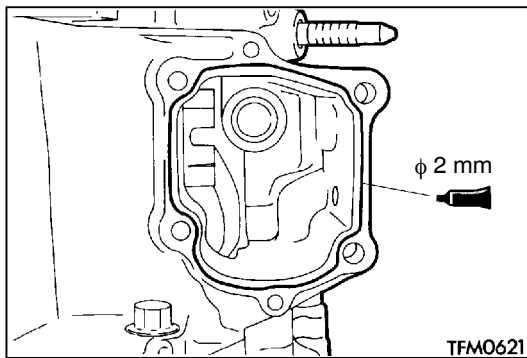

►I◄ CONTROL HOUSING INSTALLATION

Apply sealant to the illustrated position of the transmission case.

Specified sealant:
MITSUBISHI genuine sealant part No. MD997740 or equivalent

Caution
 Squeeze out the sealant uniformly, while making sure that it is not broken or excessively applied.

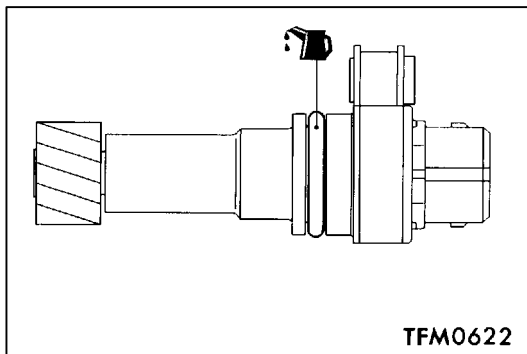

►J◄ SPEEDOMETER GEAR INSTALLATION

Apply transmission oil to the O-ring of the speedometer gear.

Transmission oil:
 Hypoid gear oil SAE 75W-85W conforming to API classification GL-4 or higher

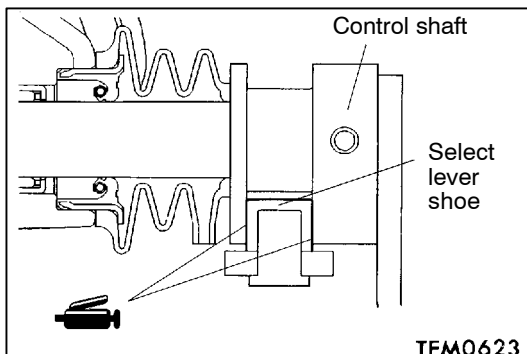

►K◄ SELECT LEVER INSTALLATION

Apply grease to the control shaft sliding portion of the select lever shoe.

Specified grease:
MITSUBISHI genuine grease part No. 0101011 or equivalent

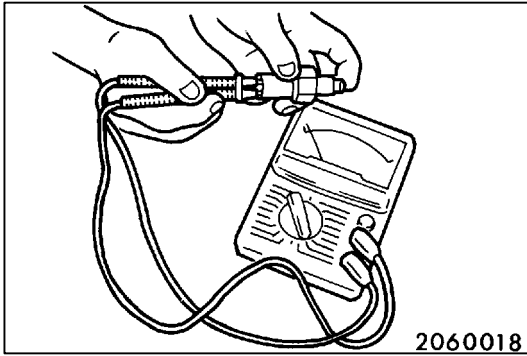
**INSPECTION****BACK-UP LAMP SWITCH**

Check for continuity between terminals.

Switch condition	Continuity
Pressed	Not exist
Released	Exists

4. INPUT SHAFT

DISASSEMBLY AND REASSEMBLY

Apply gear oil to all moving parts before installation.

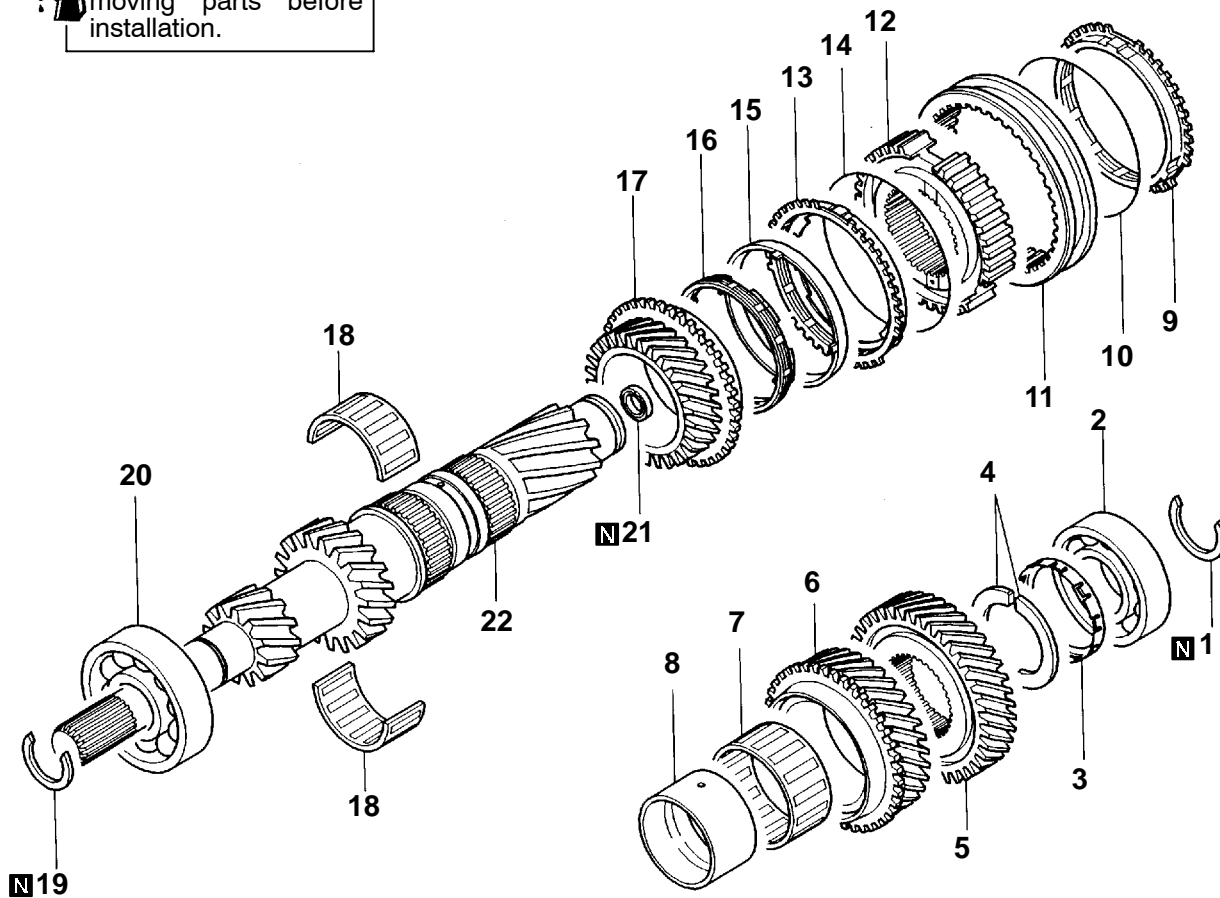

TFM0716

Disassembly steps

- | | | | | |
|-----|--------------|--------------------------|------------------------------------|-------------------------|
| ▶M◀ | 1. Snap ring | ▶E◀ | 12. 3rd-4th speed synchronizer hub | |
| ◀A▶ | ▶L◀ | 2. Ball bearing | 13. Outer synchronizer ring | |
| ◀B▶ | ▶K◀ | 3. Thrust plate stopper | ▶D◀ | 14. Synchronizer spring |
| ◀C▶ | ▶J◀ | 4. Thrust plate | 15. Synchronizer cone | |
| | ▶I◀ | 5. 5th speed gear | 16. Inner synchronizer ring | |
| | | 6. 4th speed gear | 17. 3rd speed gear | |
| ◀D▶ | ▶H◀ | 7. Needle roller bearing | 18. Needle roller bearing | |
| | | 8. 4th speed gear sleeve | ▶C◀ | 19. Snap ring |
| | ▶G◀ | 9. Synchronizer ring | ▶B◀ | 20. Ball bearing |
| | ▶F◀ | 10. Synchronizer spring | ▶A◀ | 21. Oil seal |
| | | 11. Synchronizer sleeve | ◀E▶ | 22. Input shaft |

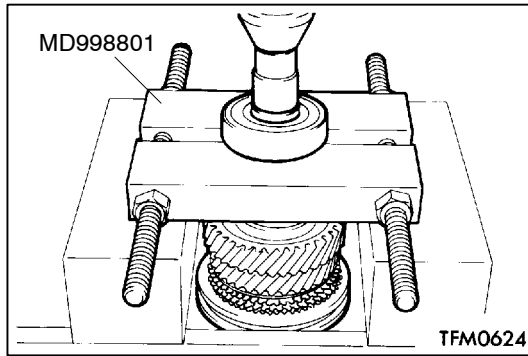
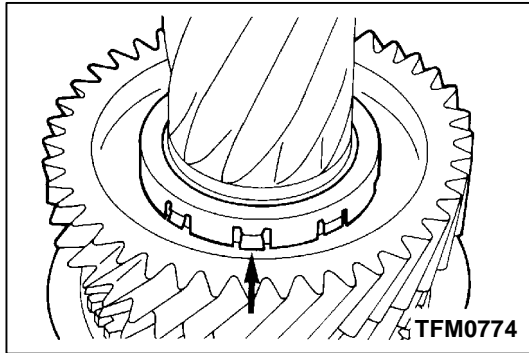
**DISASSEMBLY SERVICE POINTS****◀A▶ BALL BEARING REMOVAL****◀B▶ THRUST PLATE STOPPER REMOVAL**

Using a screwdriver, pry up the position shown in the illustration and remove the thrust plate stopper.

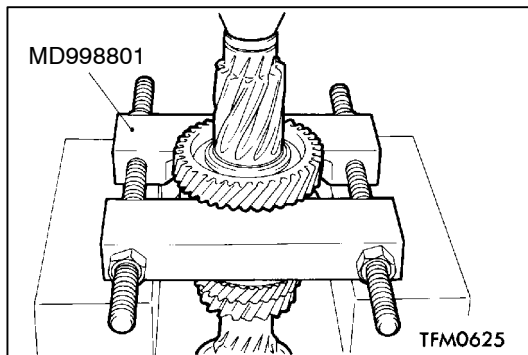
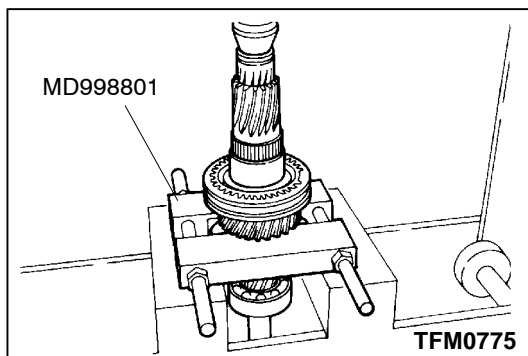
**◀C▶ 5TH SPEED GEAR REMOVAL****◀D▶ 4TH SPEED GEAR SLEEVE REMOVAL**

Install the special tool to the 3rd speed gear and remove the 4th speed gear sleeve.

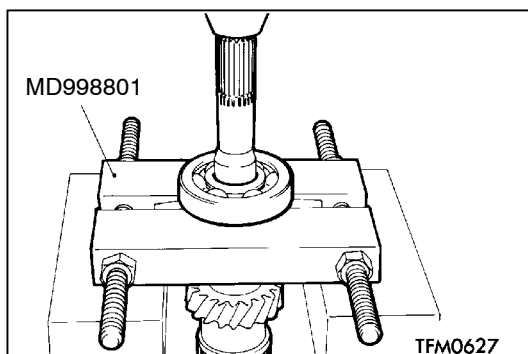
**◀E▶ BALL BEARING REMOVAL**

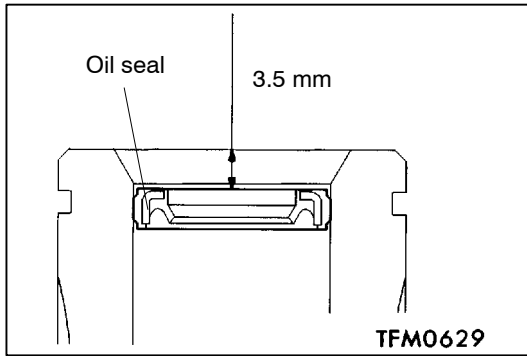

REASSEMBLY SERVICE POINTS

▶A◀ OIL SEAL INSTALLATION

Make sure that the oil seal is pressed into the position shown in the illustration.

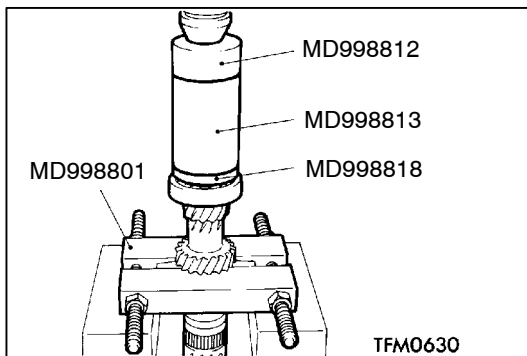

▶B◀ BALL BEARING INSTALLATION

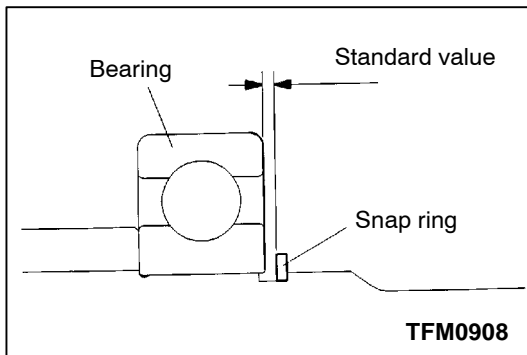

▶C◀ SNAP RING INSTALLATION

Select and install a snap ring so that the input shaft front bearing end play will have the standard value.

Standard value: -0.01 - 0.12 mm

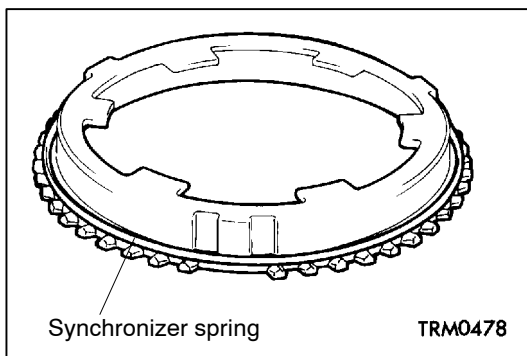

▶D◀ SYNCHRONIZER SPRING INSTALLATION

Install the synchronizer spring securely to the illustrated position of the outer synchronizer ring.

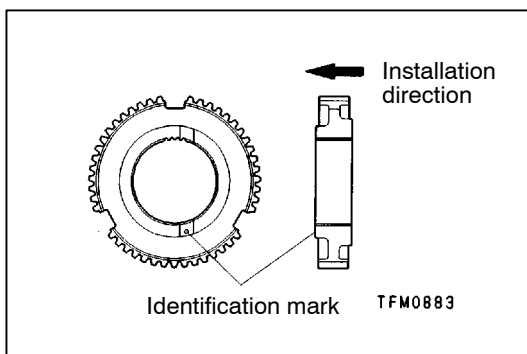

▶E◀ 3RD-4TH SPEED SYNCHRONIZER HUB INSTALLATION

Install the synchronizer hub in such a way that it will be oriented in the direction shown.

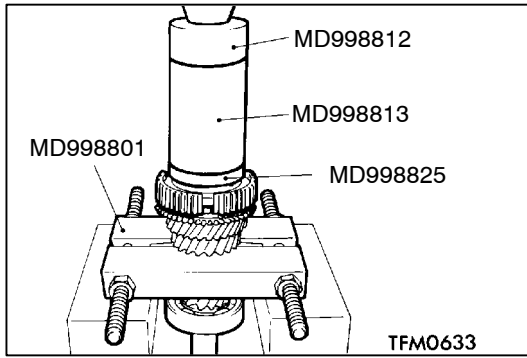

Caution

When the hub is installed, make sure that the synchronizer ring is not caught.

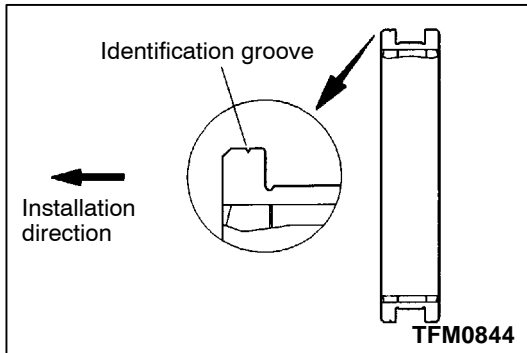

▶F◀ SYNCHRONIZER SLEEVE INSTALLATION

(1) Install the synchronizer sleeve in such a way that it will be oriented in the direction shown.

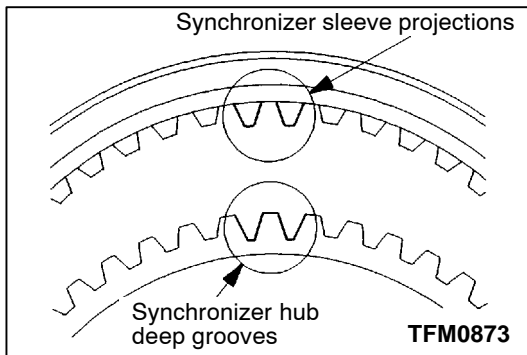

(2) When the synchronizer sleeve is installed, make sure that the deep groove portion of the synchronizer hub is aligned with the projecting portion of the sleeve.

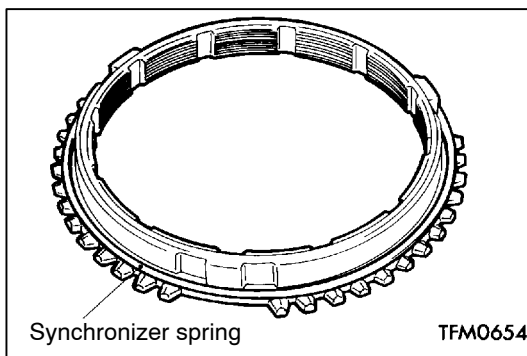

▶G◀ SYNCHRONIZER SPRING INSTALLATION

Install the synchronizer spring securely to the illustration position of synchronizer ring.

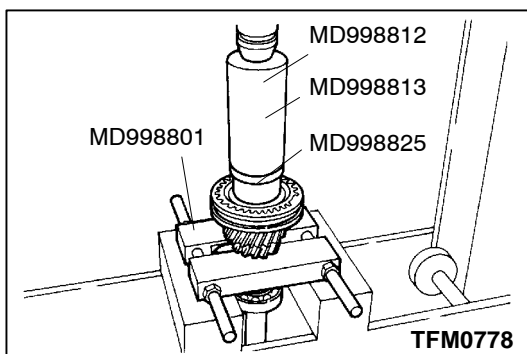

▶H◀ 4TH SPEED GEAR SLEEVE INSTALLATION

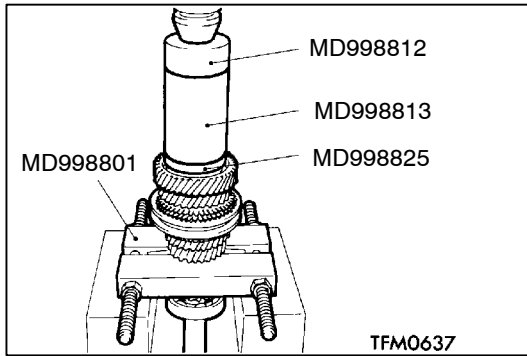

►◀ 5TH SPEED GEAR INSTALLATION

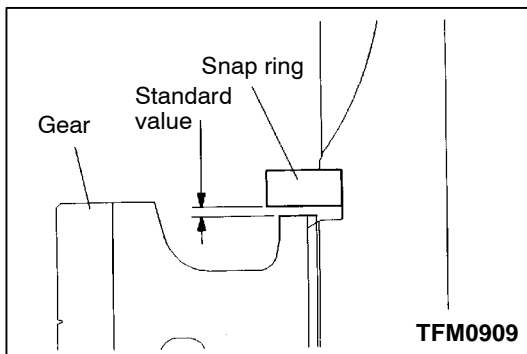

►◀ THRUST PLATE INSTALLATION

Select and install a thrust plate so that the input shaft 5th speed gear clearance will have the standard value.

Standard value: -0.01 - 0.09 mm

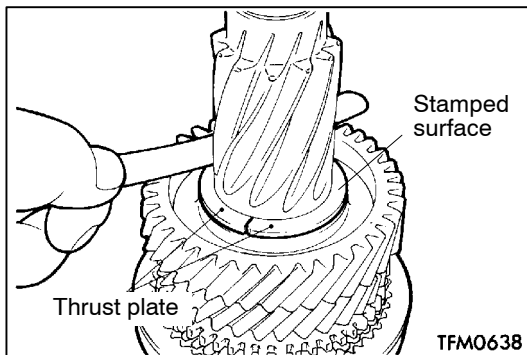

Caution

Install the plate with its identification stamped surface faced against the thrust plate stopper.

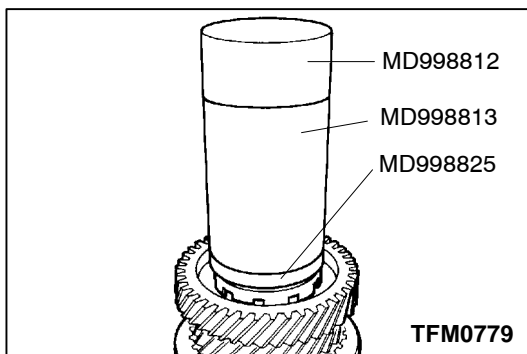

►◀ THRUST PLATE STOPPER INSTALLATION

Install the thrust plate stopper by pressing the special tools with hand. Make sure that the stopper is not installed aslant.

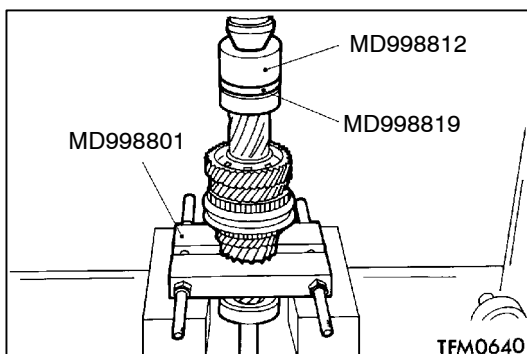

►◀ BALL BEARING INSTALLATION

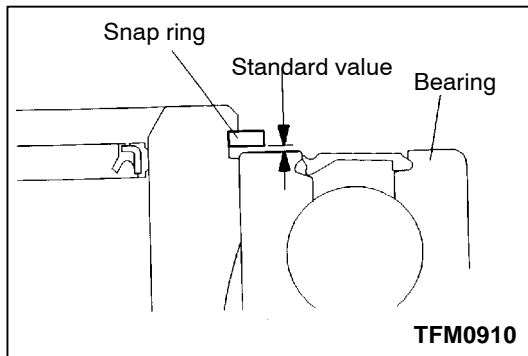

▶◀SNAP RING INSTALLATION

Select and install a snap ring so that the input shaft rear bearing clearance will have the standard value.

Standard value: -0.01 - 0.12 mm

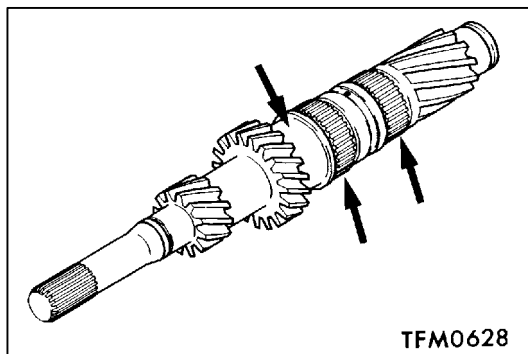

INSPECTION

INPUT SHAFT

- (1) Check the outside diameter of the needle bearing mounting portion for damage, abnormal wear and seizure.
- (2) Check the splines for damage and wear.

NEEDLE ROLLER BEARING

- (1) Check to ensure that when the input shaft and gear are combined and made to rotate, they rotate smoothly without looseness and noise.
- (2) Check to ensure that the cage is not deformed.

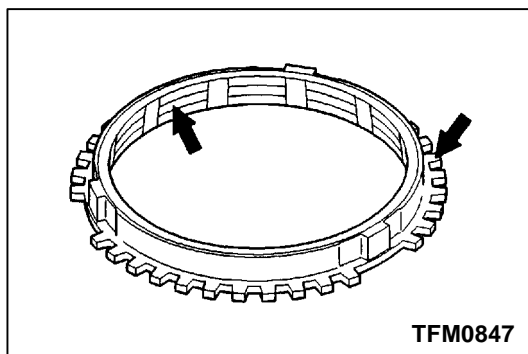

SYNCHRONIZER RING

- (1) Check to ensure that the clutch gear tooth surfaces are not damaged and broken.
- (2) Check to ensure that the cone inside surface is not damaged or worn and that the threads are not crushed.

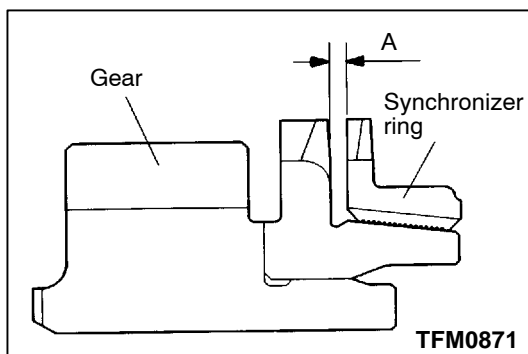

- (3) Press the synchronizer ring against the gear and check clearance "A". If "A" is less than the limit, replace.

Limit: 0.5 mm

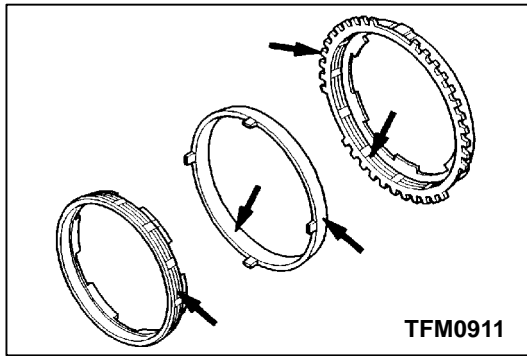

OUTER SYNCHRONIZER RING / INNER SYNCHRONIZER RING / SYNCHRONIZER CONE

- (1) Check to ensure that the clutch gear tooth surface and cone surface are not damaged and broken.

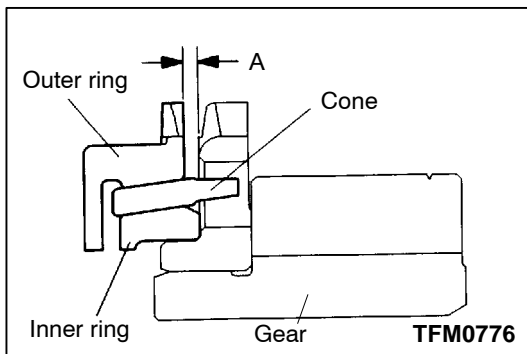

- (2) Install the outer ring, inner ring and cone, press them against the gear, and check clearance "A". If "A" is less than the limit, replace.

Limit: 0.5 mm

Caution

When any of the outer ring, inner ring or cone has to be replaced, replace them as a set.

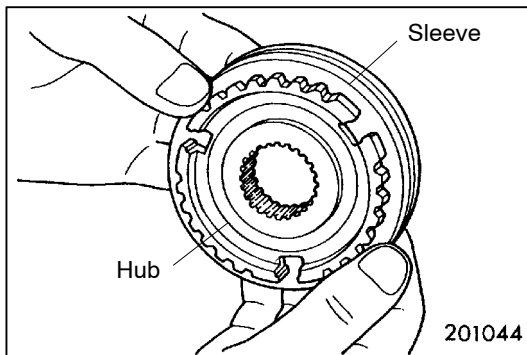

SYNCHRONIZER SLEEVE AND HUB

- (1) Check to ensure that when the synchronizer sleeve and hub are combined and made to slide, they slide smoothly without binding.
- (2) Check to ensure that the front and rear ends of the sleeve inside surface are not damaged.

Caution

When replacement of either the synchronizer sleeve or hub is necessary, make sure that the synchronizer sleeve and hub are replaced as a set.

SYNCHRONIZER SPRING

Check to ensure that the spring is not sagging, deformed or broken.

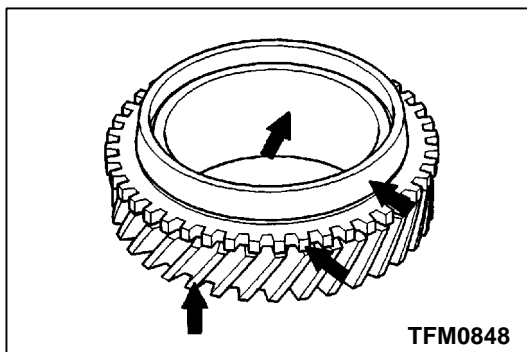

SPEED GEARS

- (1) Check to ensure that the helical and clutch gear tooth surfaces are not damaged or worn.
- (2) Check to ensure that the synchronizer cone surfaces are not roughened, damaged or worn.
- (3) Check to ensure that the gear inside diameter and front and rear surfaces are not damaged and worn.

5. OUTPUT SHAFT

DISASSEMBLY AND REASSEMBLY

 Apply gear oil to all moving parts before installation.

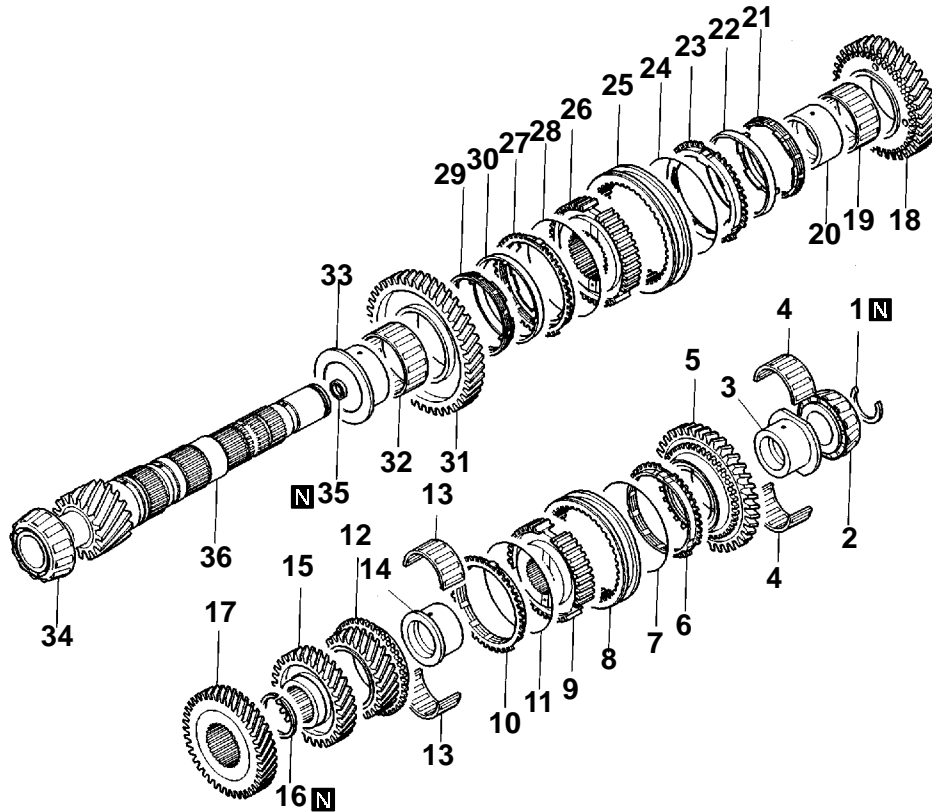

TFM0884

Disassembly steps

- | | | | | | |
|-----|-----|---------------------------------------|-----|-----|------------------------------------|
| ◀A▶ | ▶P▶ | 1. Snap ring | ▶E▶ | ▶G▶ | 19. Needle roller bearing |
| ◀B▶ | ▶O▶ | 2. Taper roller bearing | | | 20. 2nd speed gear sleeve |
| | ▶N▶ | 3. Reverse gear bearing sleeve | | | 21. Inner synchronizer ring |
| | ▶N▶ | 4. Needle roller bearing | | | 22. Synchronizer cone |
| | ▶N▶ | 5. Reverse gear | | | 23. Outer synchronizer ring |
| | | 6. Synchronizer ring | | ▶D▶ | 24. Synchronizer spring |
| | ▶L▶ | 7. Synchronizer spring | ▶F▶ | ▶F▶ | 25. Synchronizer sleeve |
| | ▶F▶ | 8. Synchronizer sleeve | ▶E▶ | ▶E▶ | 26. 1st-2nd speed synchronizer hub |
| ◀C▶ | ▶M▶ | 9. 5th-reverse speed synchronizer hub | | ▶D▶ | 27. Outer synchronizer ring |
| | | 10. Synchronizer ring | | | 28. Synchronizer spring |
| | ▶L▶ | 11. Synchronizer spring | | | 29. Inner synchronizer ring |
| | | 12. 5th speed gear | | | 30. Synchronizer cone |
| | | 13. Needle roller bearing | | | 31. 1st speed gear |
| | ▶K▶ | 14. 5th speed gear sleeve | | ▶F▶ | 32. Needle roller bearing |
| | ▶J▶ | 15. 4th speed gear | ◀F▶ | ▶C▶ | 33. 1st speed gear sleeve |
| | ▶I▶ | 16. Snap ring | ◀G▶ | ▶B▶ | 34. Taper roller bearing |
| ◀D▶ | ▶H▶ | 17. 3rd speed gear | | ▶A▶ | 35. Oil seal |
| | | 18. 2nd speed gear | | | 36. Output shaft |

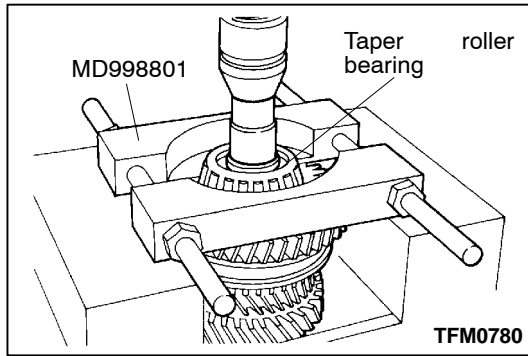
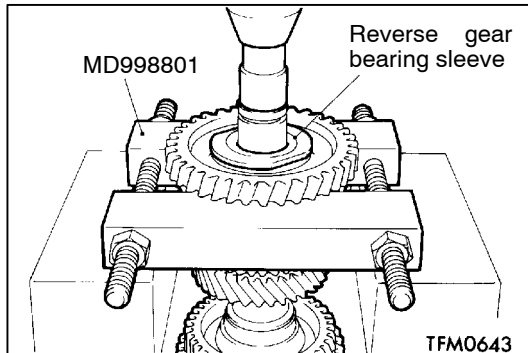
**DISASSEMBLY SERVICE POINTS****◀A▶ TAPER ROLLER BEARING REMOVAL****◀B▶ REVERSE GEAR BEARING SLEEVE REMOVAL**

Mount a special tool on the reverse gear and remove the reverse gear bearing sleeve.

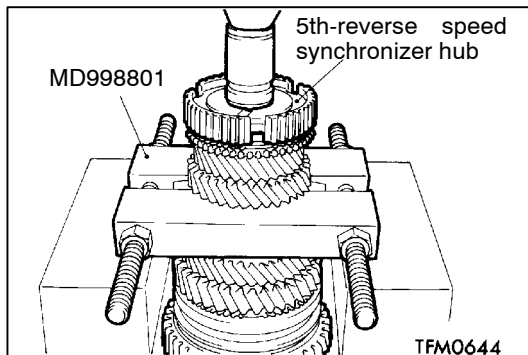
**◀C▶ 5TH-REVERSE SPEED SYNCHRONIZER HUB REMOVAL**

Mount a special tool on the 4th speed gear and remove the 5th-reverse speed synchronizer hub.

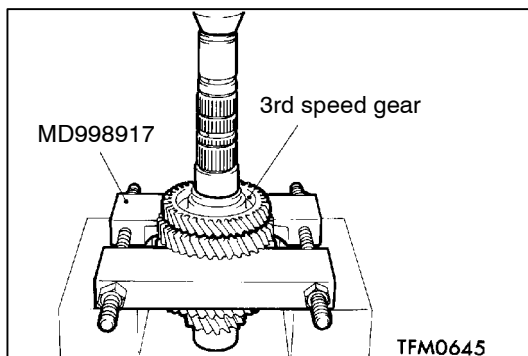
**◀D▶ 3RD SPEED GEAR REMOVAL**

Mount a special tool on the 2nd speed gear and remove the 3rd speed gear.

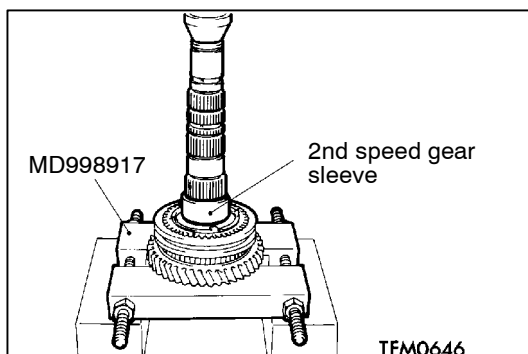
**◀E▶ 2ND SPEED GEAR SLEEVE REMOVAL**

Mount a special tool on the 1st speed gear and remove the 2nd speed gear sleeve.

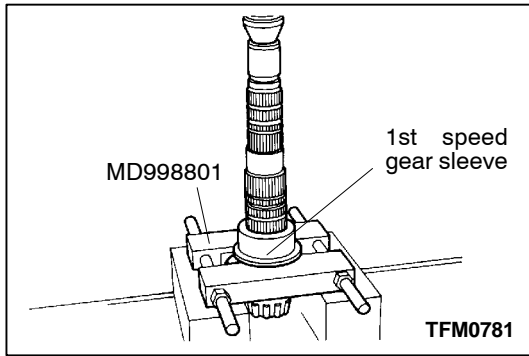

◀F▶ 1ST SPEED GEAR SLEEVE REMOVAL

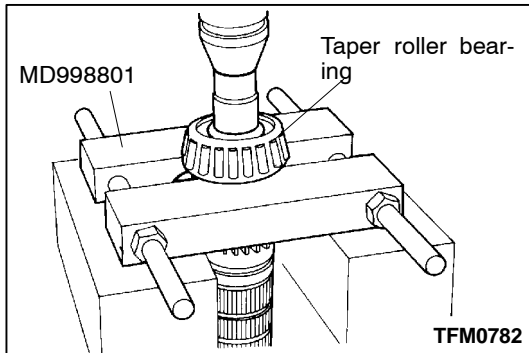

▶G▶ TAPER ROLLER BEARING REMOVAL

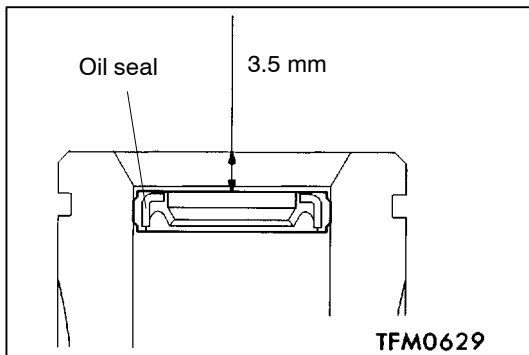

REASSEMBLY SERVICE POINTS

▶A▶ OIL SEAL INSTALLATION

Make sure that the oil seal is pressed into the position shown in the illustration.

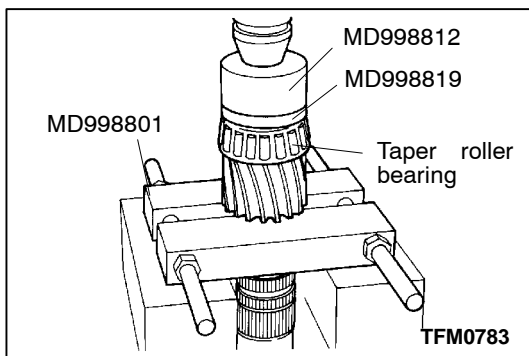

▶B▶ TAPER ROLLER BEARING INSTALLATION

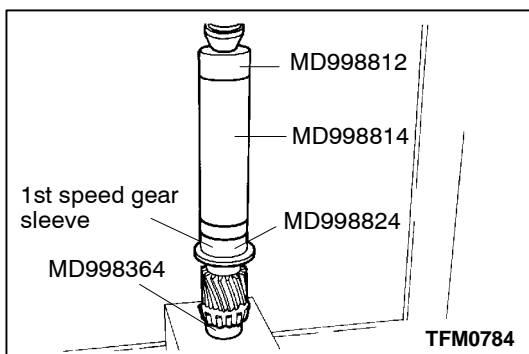

▶C▶ 1ST SPEED GEAR SLEEVE INSTALLATION

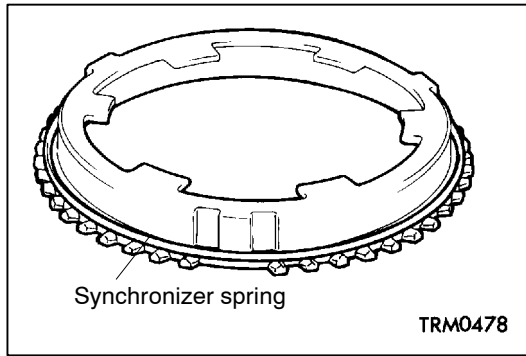

►D◄ SYNCHRONIZER SPRING INSTALLATION

Install the synchronizer spring securely to the illustrated position of the outer synchronizer ring.

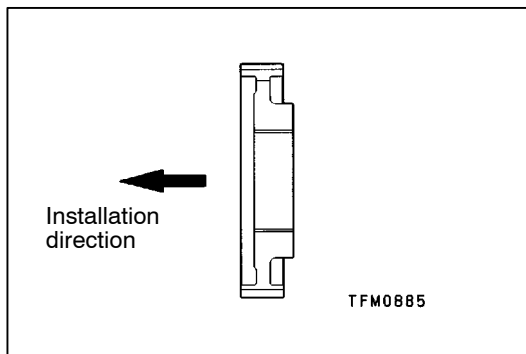

►E◄ 1ST-2ND SPEED SYNCHRONIZER HUB INSTALLATION

Install the 1st-2nd speed synchronizer hub in such a way that it will be oriented in the direction shown.

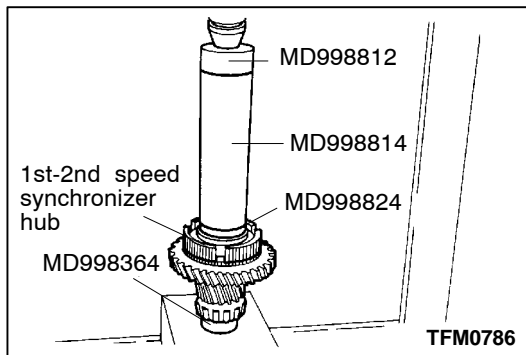

Caution

When the hub is installed, make sure that the synchronizer ring is not caught.

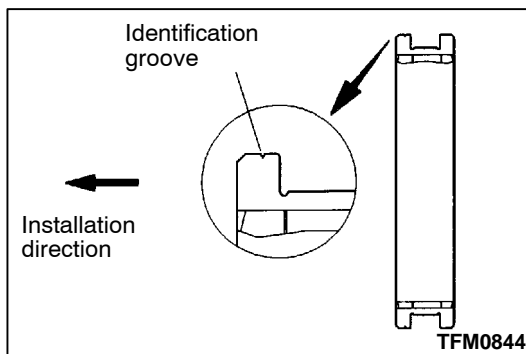

►F◄ SYNCHRONIZER SLEEVE INSTALLATION

(1) Install the synchronizer sleeve in such a way that it will be oriented in the direction shown.

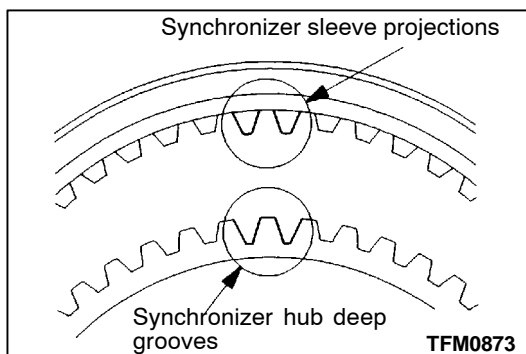

(2) When the synchronizer sleeve is installed, make sure that the deep groove portion of the synchronizer hub is aligned with the projecting portion of the sleeve.

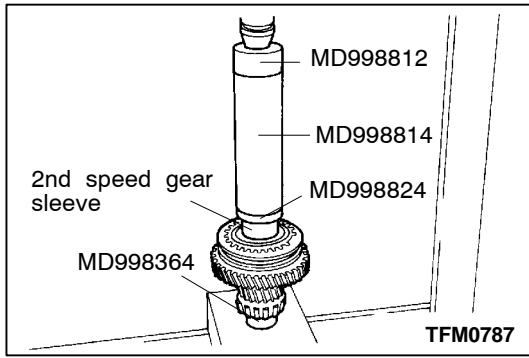

▶G◀ 2ND SPEED GEAR SLEEVE INSTALLATION

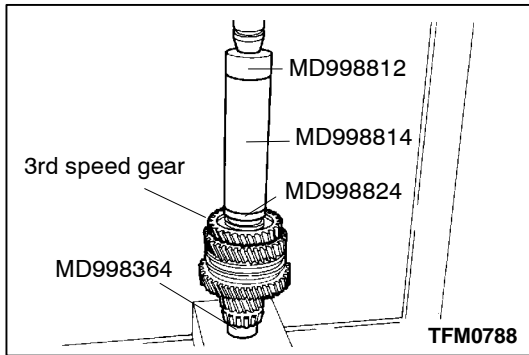

▶H◀ 3RD SPEED GEAR INSTALLATION

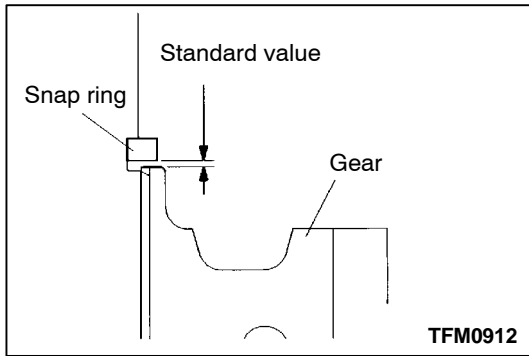

▶I◀ SNAP RING INSTALLATION

Select and install a snap ring so that the output shaft 3rd speed gear clearance will have the standard value.

Standard value: -0.01 - 0.09 mm

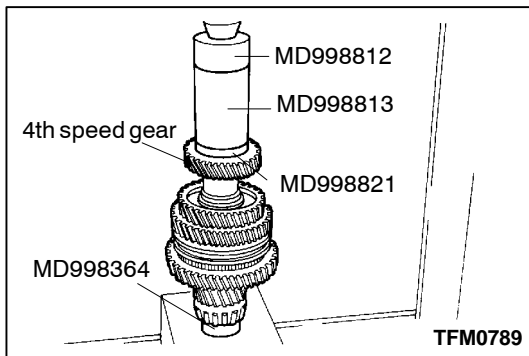

▶J◀ 4TH SPEED GEAR INSTALLATION

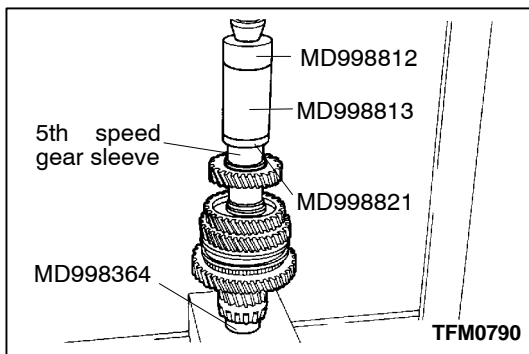

▶K◀ 5TH SPEED GEAR SLEEVE INSTALLATION

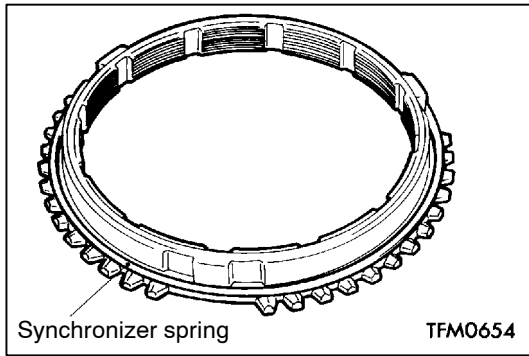

►L◄ SYNCHRONIZER SPRING INSTALLATION

Install the synchronizer spring securely up to the illustrated position of the outer synchronizer ring.

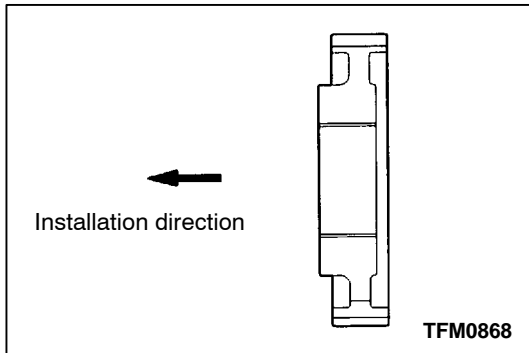

►M◄ 5TH-REVERSE SPEED SYNCHRONIZER HUB INSTALLATION

Install the 5th-reverse speed synchronizer hub in such a way that it will be oriented in the direction shown.

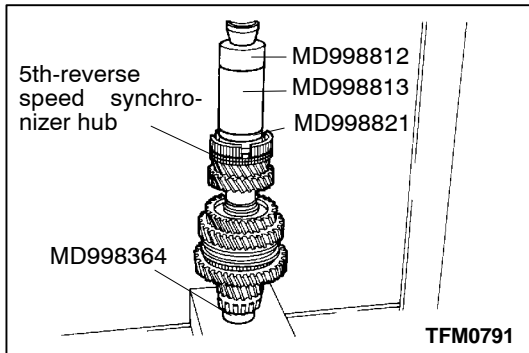

Caution

When the hub is installed, make sure that the synchronizer ring is not caught.

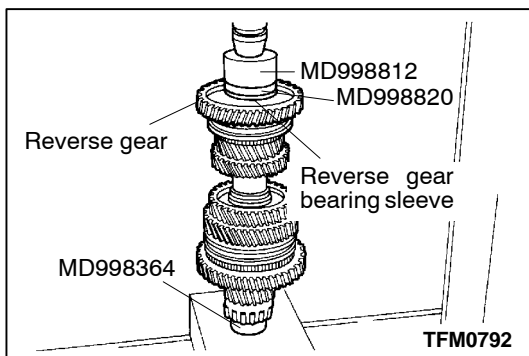

►N◄ REVERSE GEAR / NEEDLE ROLLER BEARING / REVERSE GEAR BEARING SLEEVE INSTALLATION

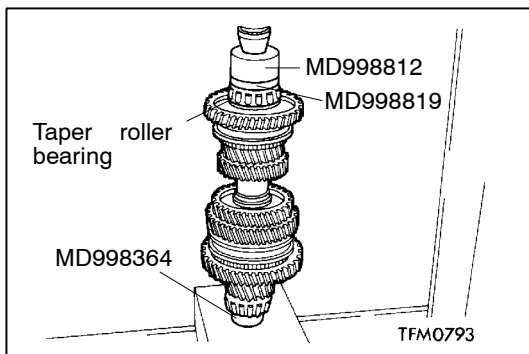

►O◄ TAPER ROLLER BEARING INSTALLATION

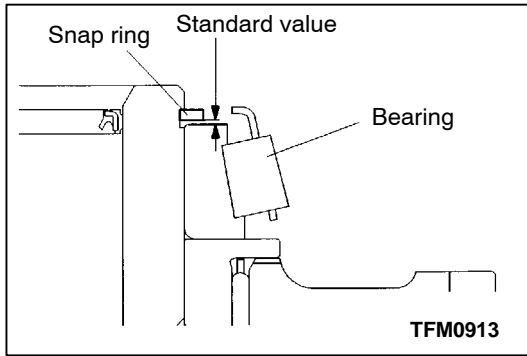

▶P◀ SNAP RING INSTALLATION

Select and install a snap ring so that the output shaft rear bearing clearance will have the standard value.

Standard value: -0.01 - 0.09 mm

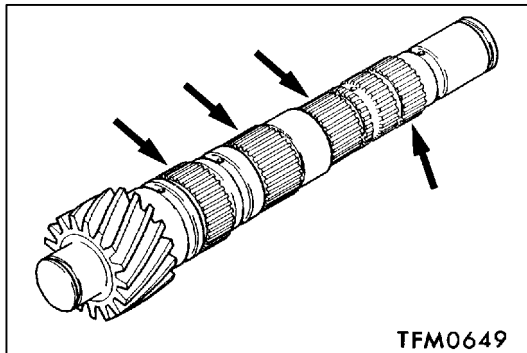

INSPECTION

OUTPUT SHAFT

Check the splines for damage and wear.

NEEDLE ROLLER BEARING

- (1) Check to ensure that when the bearing sleeve and gear are combined and made to rotate, they rotate smoothly without looseness and noise.

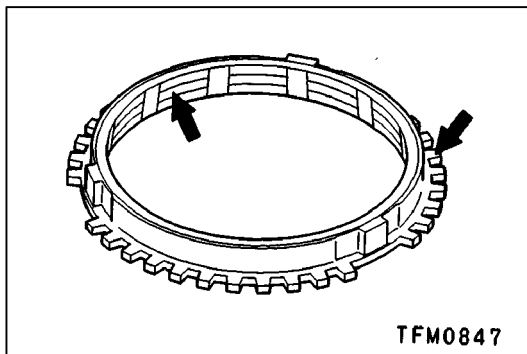

SYNCHRONIZER RING

- (1) Check to ensure that the clutch gear tooth surfaces are not damaged and broken.
- (2) Check to ensure that the cone inside diameter is not damaged or worn and that the threads are not crushed.

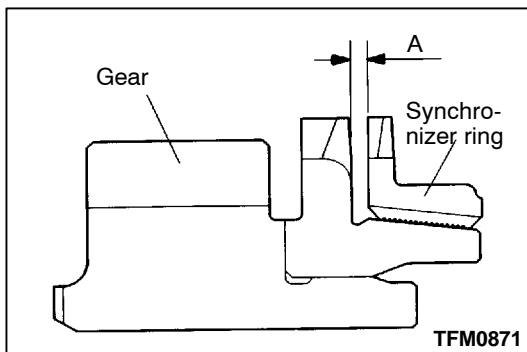

- (3) Press the synchronizer ring against the gear and check clearance "A". If "A" is less than the limit, replace.

Limit: 0.5 mm

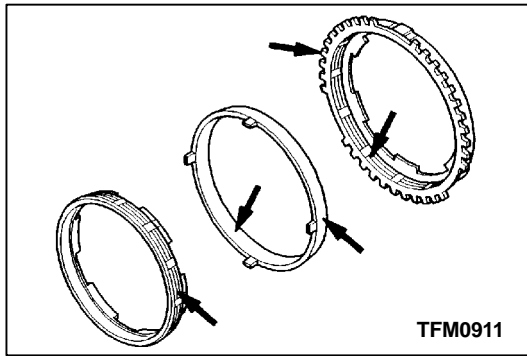

OUTER SYNCHRONIZER RING / INNER SYNCHRONIZER RING / SYNCHRONIZER CONE

- (1) Check to ensure that the clutch gear tooth surfaces and cone surfaces are not damaged and broken.

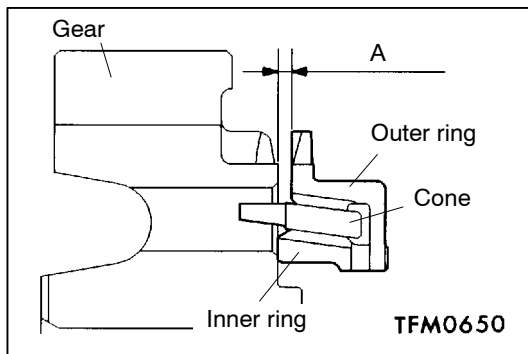

- (2) Install the outer ring, inner ring and cone, press them against the gear, and check clearance "A". If "A" is less than the limit, replace.

Limit: 0.5 mm

Caution

When any of the outer ring, inner ring or cone has to be replaced, replace them as a set.

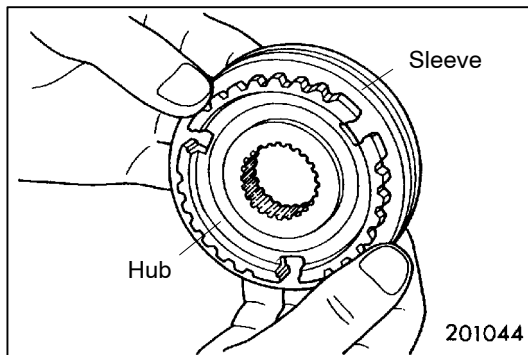

SYNCHRONIZER SLEEVE AND HUB

- (1) Check to ensure that when the synchronizer sleeve and hub are combined and made to slide, they slide smoothly without binding.
- (2) Check to ensure that the front and rear ends of the sleeve inside surface are not damaged.

Caution

When replacement of either the synchronizer sleeve or hub is necessary, make sure that the synchronizer sleeve and hub are replaced as a set.

SYNCHRONIZER SPRING

Check to ensure that the spring is not sagging, deformed or broken.

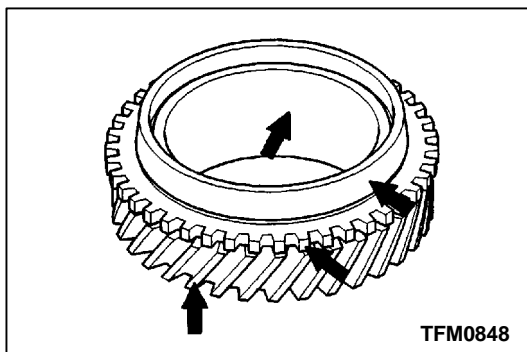

SPEED GEARS

- (1) Check to ensure that the helical and clutch gear tooth surfaces are not damaged or worn.
- (2) Check to ensure that the synchronizer cone surfaces are not roughened, damaged or worn.
- (3) Check to ensure that the gear inside diameter and front and rear surfaces are not damaged and worn.

6. REVERSE IDLER GEAR DISASSEMBLY AND REASSEMBLY

 Apply gear oil to all moving parts before installation.

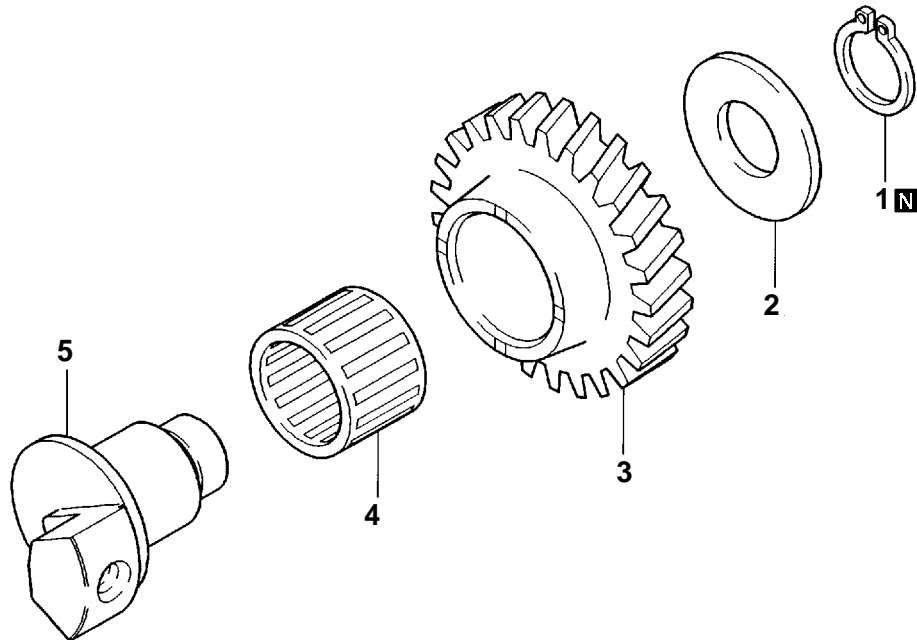

TFM0807

Disassembly steps

1. Snap ring
2. Thrust washer
3. Reverse idler gear
4. Needle roller bearing
5. Reverse idler gear shaft

INSPECTION

NEEDLE ROLLER BEARING

- (1) Check to ensure that when the shaft and gear are combined and made to rotate, they rotate smoothly without looseness and noise.
- (2) Check to ensure that the cage is not deformed.

7. SPEEDOMETER GEAR

DISASSEMBLY AND REASSEMBLY

 Apply gear oil to all moving parts before installation.

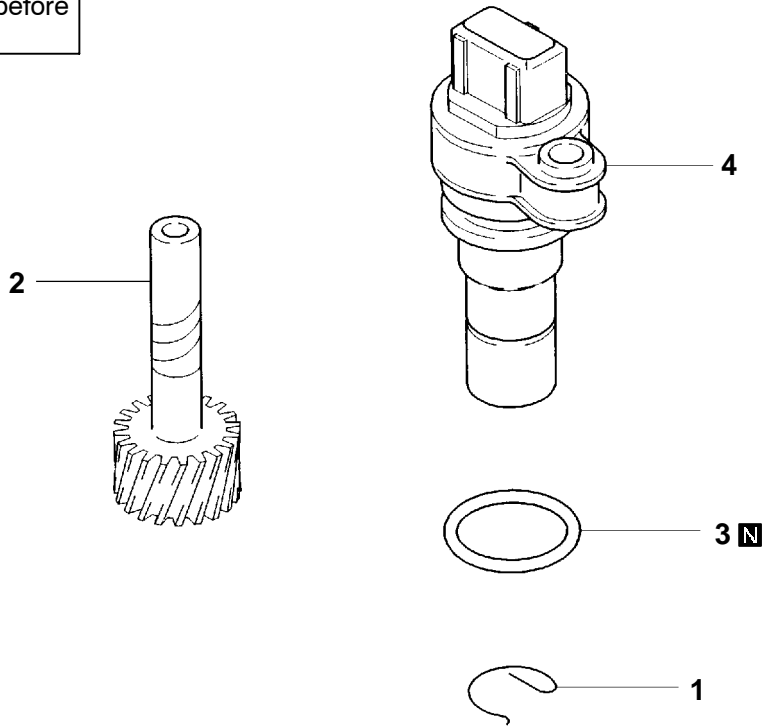

Disassembly steps

1. e-clip
2. Speedometer driven gear
3. O-ring
4. Sleeve

TFM0593

8. SELECT LEVER

DISASSEMBLY AND REASSEMBLY

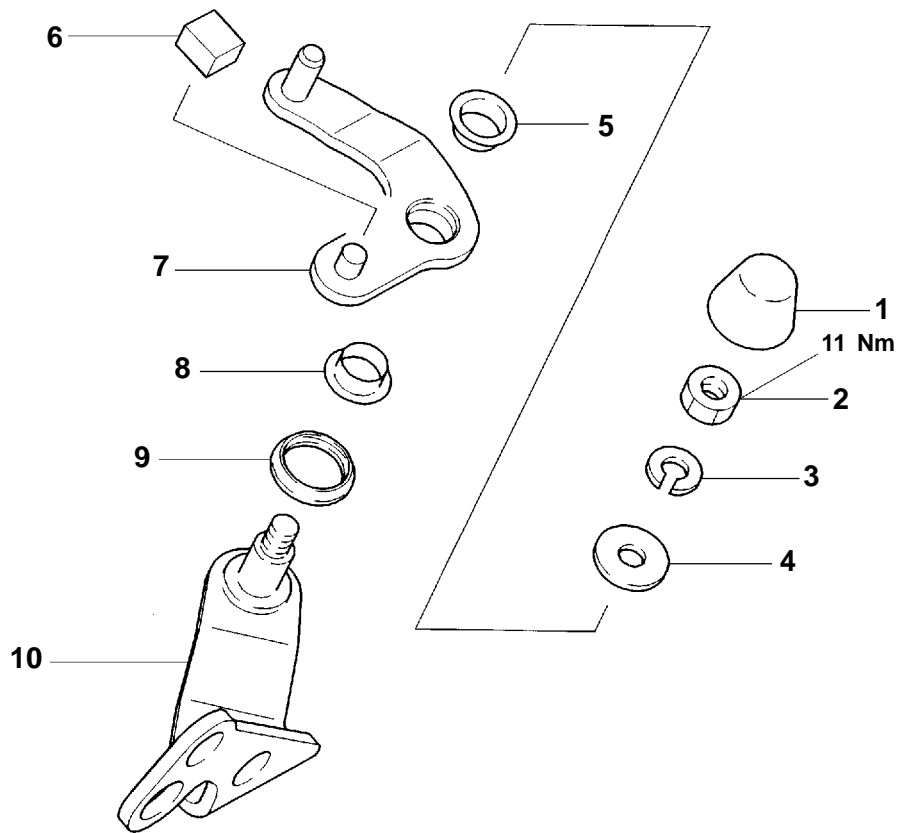

TFM0589

Disassembly steps

- ▶A◀
1. Dust cover
 2. Nut
 3. Spring washer
 4. Washer
 5. Select lever bushing

- ▶A◀
6. Select lever shoe
 7. Select lever
 8. Select lever bushing
 9. Dust cover
 10. Select lever shaft

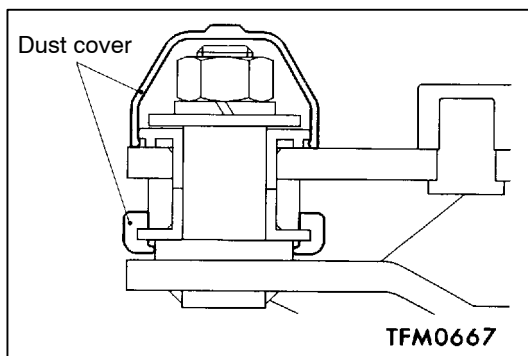

REASSEMBLY SERVICE POINT

◀A▶ DUST COVER INSTALLATION

9. CONTROL HOUSING

DISASSEMBLY AND REASSEMBLY

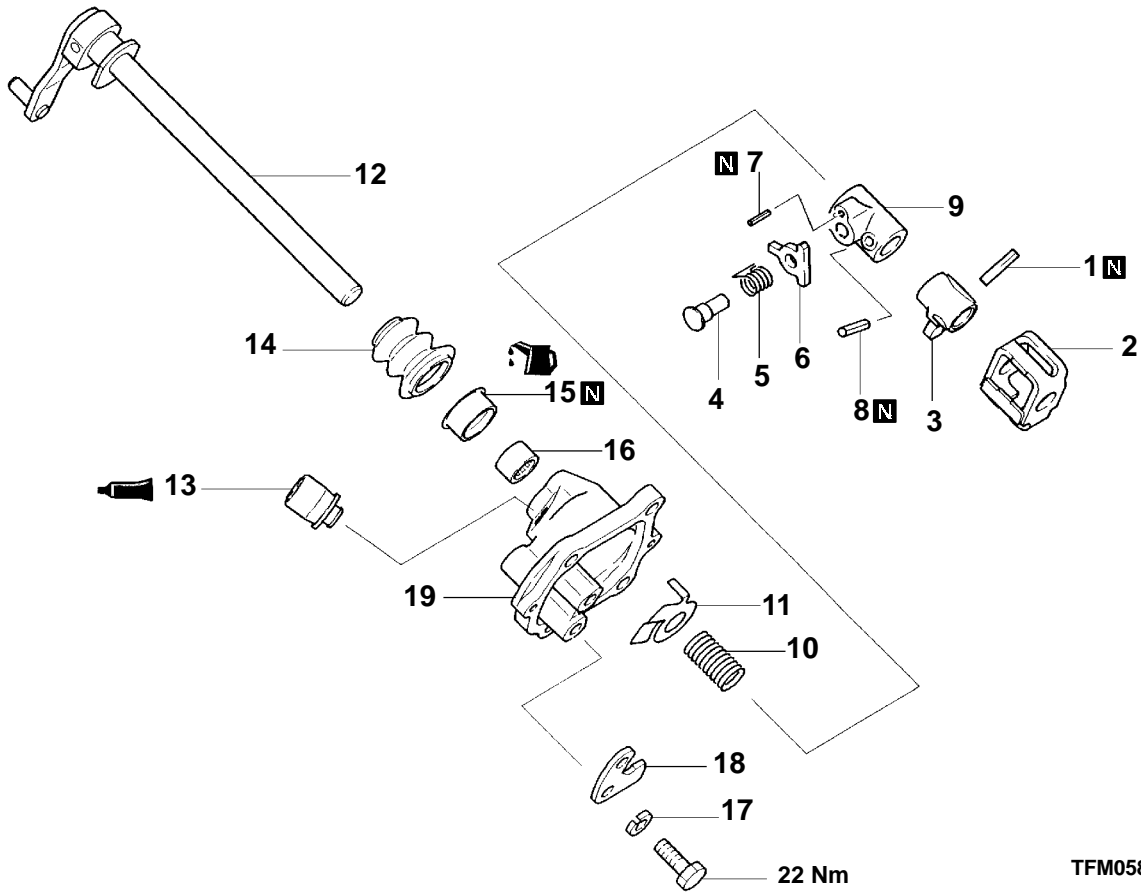

TFM0588

Disassembly steps

- ◀A▶ ▶F▶ 1. Lock pin
- ▶C▶ 2. Interlock plate
- ▶B▶ 3. Control finger
- ▶A▶ 4. Pin
- ▶E▶ 5. Return spring
- ▶D▶ 6. Stopper plate
- 7. Spring pin
- 8. Spring pin
- 9. Stopper body
- 10. Neutral return spring

- 11. Spacer
- 12. Control shaft
- 13. Air breather
- 14. Control shaft boot
- 15. Oil seal
- 16. Needle bearing
- 17. Spring washer
- 18. Stopper bracket
- 19. Control housing

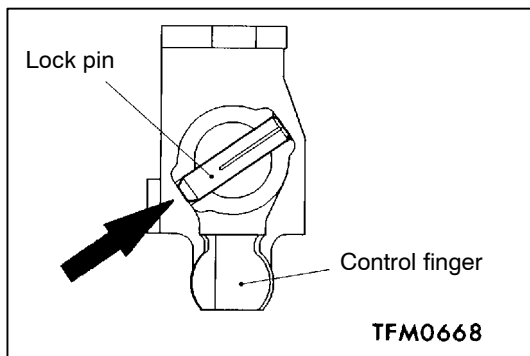
**DISASSEMBLY SERVICE POINT****◀A▶ LOCK PIN REMOVAL**

Drive the lock pin out of position from the direction shown.

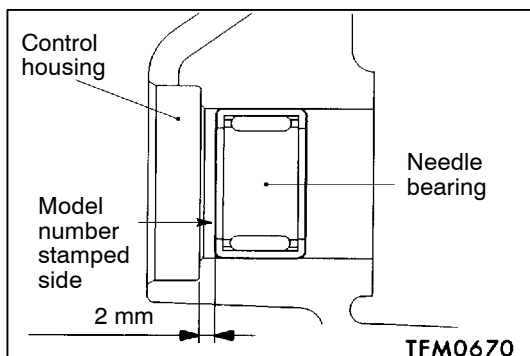
**REASSEMBLY SERVICE POINTS****▶A◀ NEEDLE BEARING INSTALLATION**

Press fit the needle bearing to the position shown in the illustration, while making sure that the model number stamped side is oriented in the direction shown.

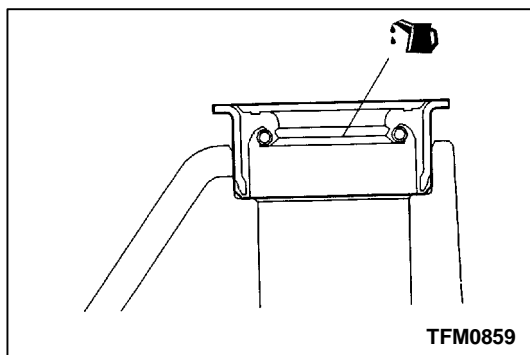
**▶B◀ OIL SEAL INSTALLATION**

Apply transmission oil to the oil seal lip area.

Transmission oil:

Hypoid gear oil SAE 75W-85W conforming to API classification GL-4 or higher

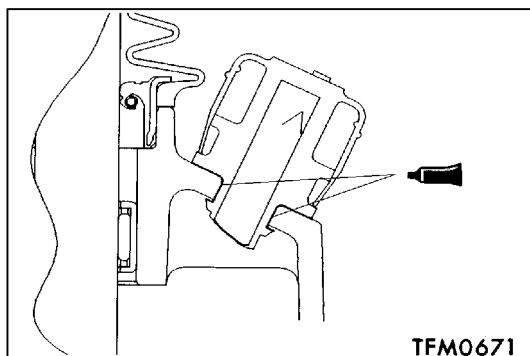
**▶C◀ AIR BREATHER INSTALLATION**

- (1) Apply a sealant to the outside circumference of the inserting portion.

Specified sealant:

3M SUPER WEATHERSTRIP No. 8001 or equivalent

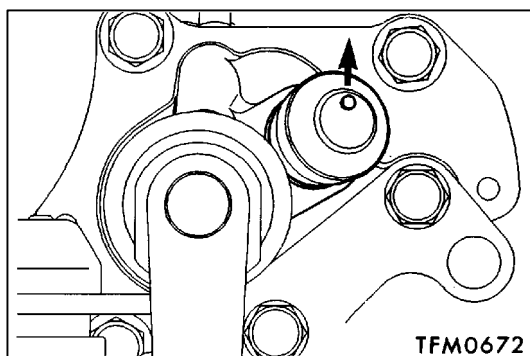

- (2) Make sure that the projecting portion is oriented in the direction shown.

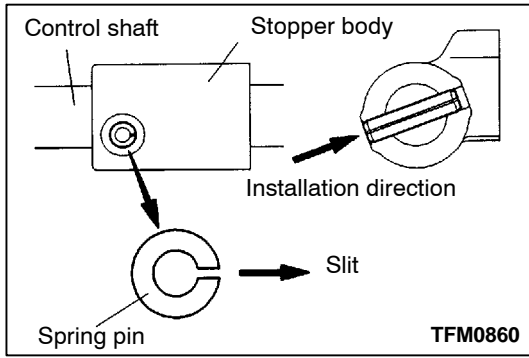

▶D◀ SPRING PIN INSTALLATION

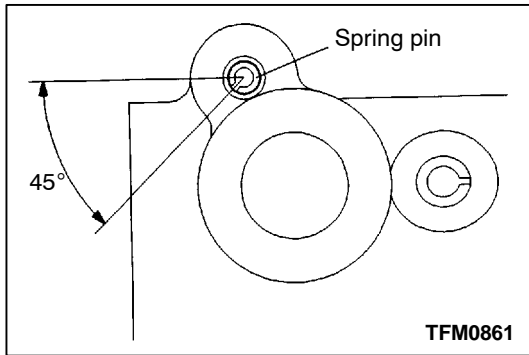

▶E◀ SPRING PIN INSTALLATION

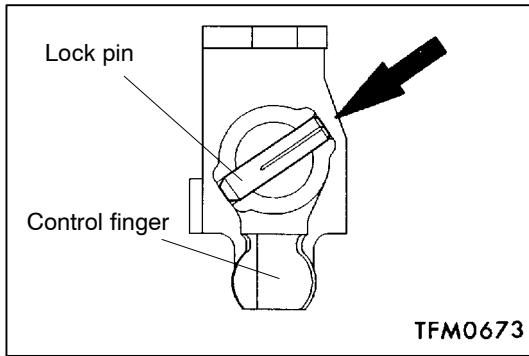

▶F◀ LOCK PIN INSTALLATION

Drive in the lock pin in the direction shown in the illustration.

10. CLUTCH HOUSING

DISASSEMBLY AND REASSEMBLY

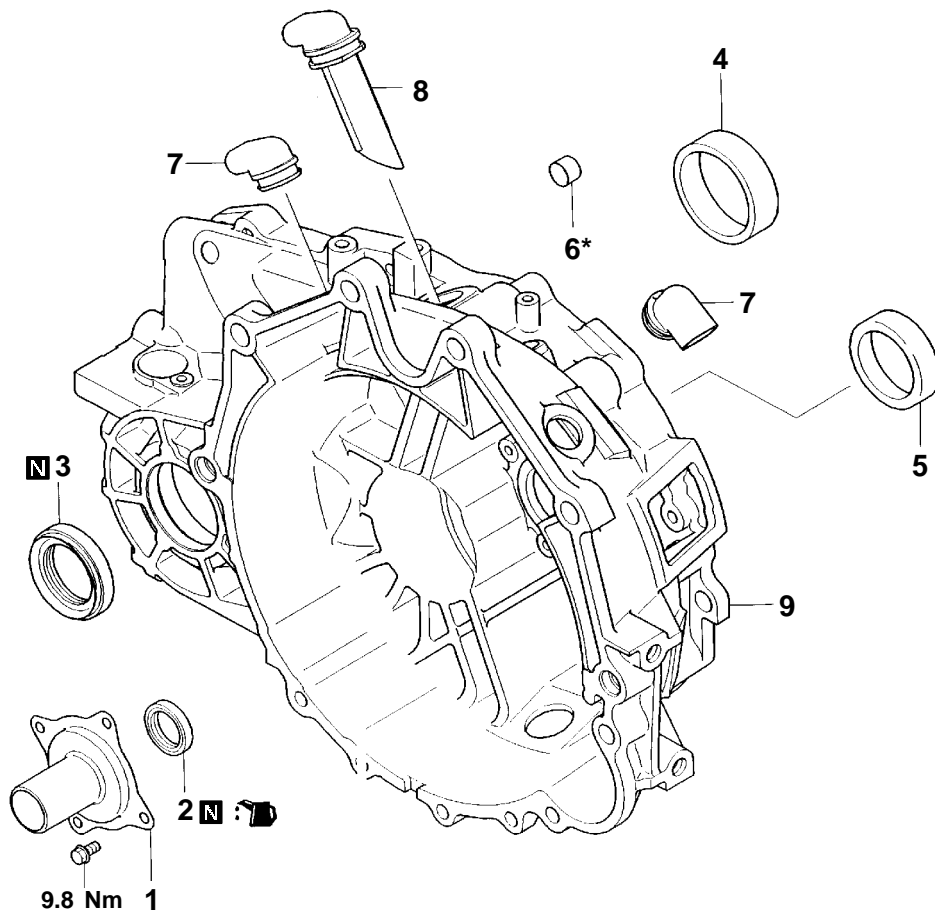

TFM0914

Disassembly steps

- | | | | | |
|---|---|--|--|--|
| <p> ◀A▶
 ▶B▶ </p> | <p> ▶F▶
 ▶E▶
 ▶D▶
 ▶C▶ </p> | <ol style="list-style-type: none"> 1. Clutch release bearing retainer 2. Oil seal 3. Oil seal 4. Outer race 5. Outer race | <p> ▶B▶
 ▶A▶
 ▶A▶ </p> | <ol style="list-style-type: none"> 6. Bushing* 7. Cover-A 8. Cover-B 9. Clutch housing |
|---|---|--|--|--|

NOTE:

*: Never remove the bushings from the clutch housing.
 Only the case when installing new bushings into a new clutch housing, refer to ▶B▶.

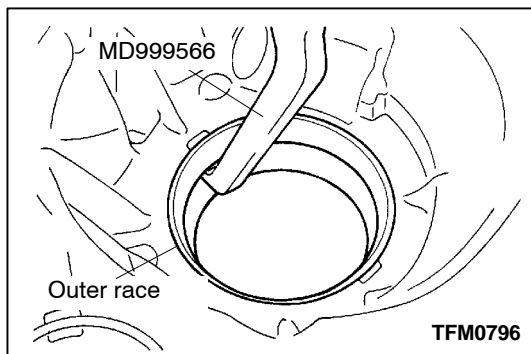

DISASSEMBLY SERVICE POINTS

◀A▶ OUTER RACE REMOVAL

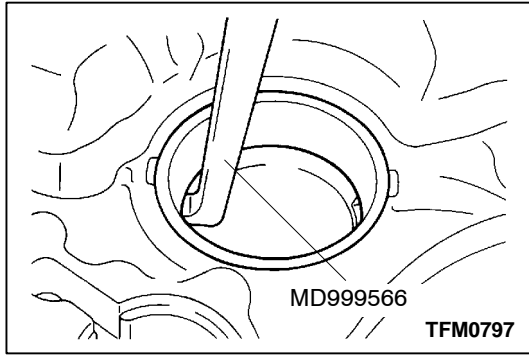

◀B▶ OUTER RACE REMOVAL

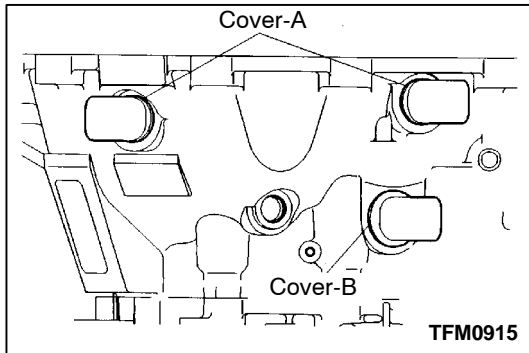

REASSEMBLY SERVICE POINTS

▶A◀ COVER-B / COVER-A INSTALLATION

Install the covers directed as shown in the illustration

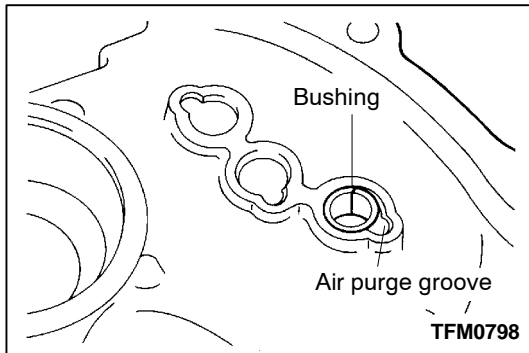

▶B◀ BUSHING INSTALLATION

Press fit the bushing to the illustrated position, while making sure that the split ends of the bushing do not coincide with the air purge groove.

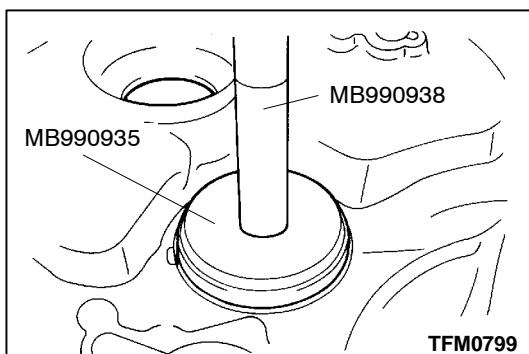
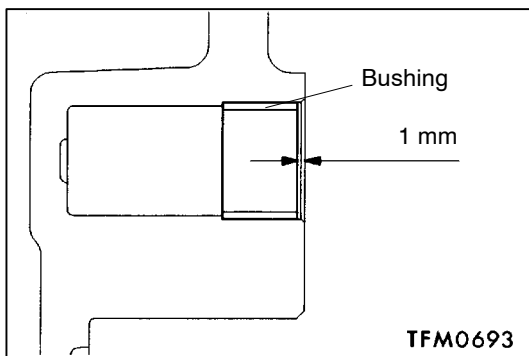

▶C◀ OUTER RACE INSTALLATION

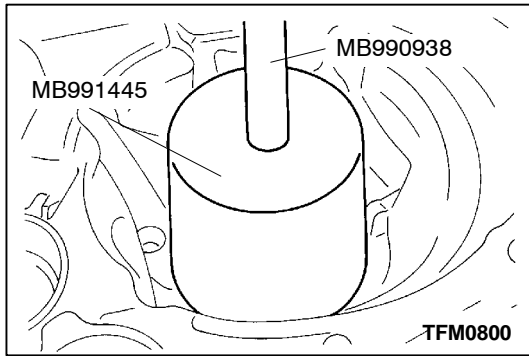

▶D◀ OUTER RACE INSTALLATION

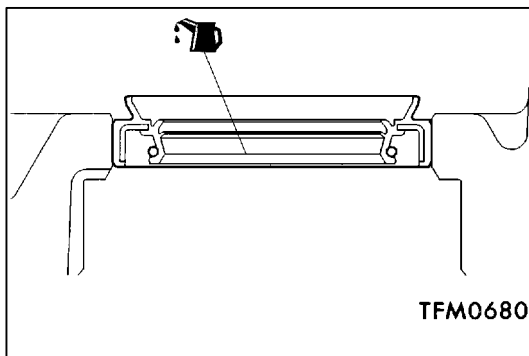

▶E◀ OIL SEAL INSTALLATION

Apply transmission oil to the oil seal lip area.

Transmission oil:

Hypoid gear oil SAE 75W-85W conforming to API classification GL-4 or higher

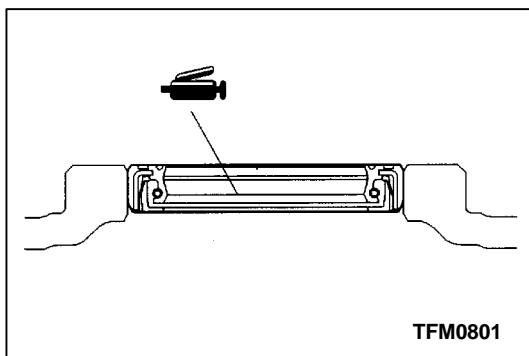
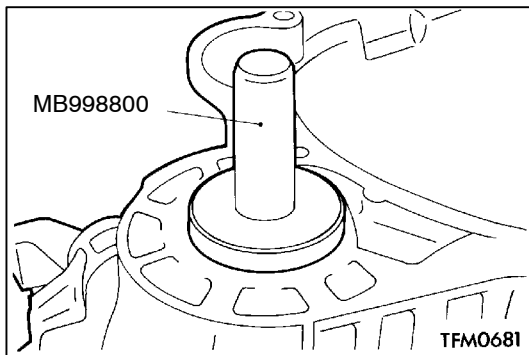

▶F◀ OIL SEAL INSTALLATION

Pack grease in the oil seal lip area.

Specified grease:

MITSUBISHI genuine grease Part No. 0101011 or equivalent

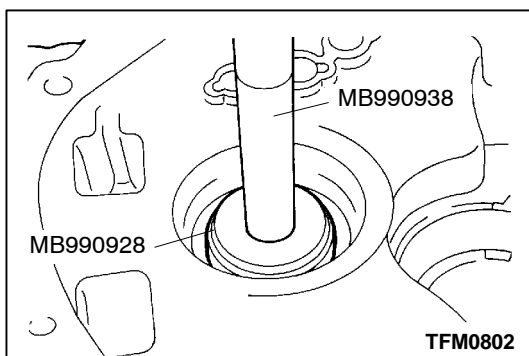

11. TRANSMISSION CASE

DISASSEMBLY AND REASSEMBLY

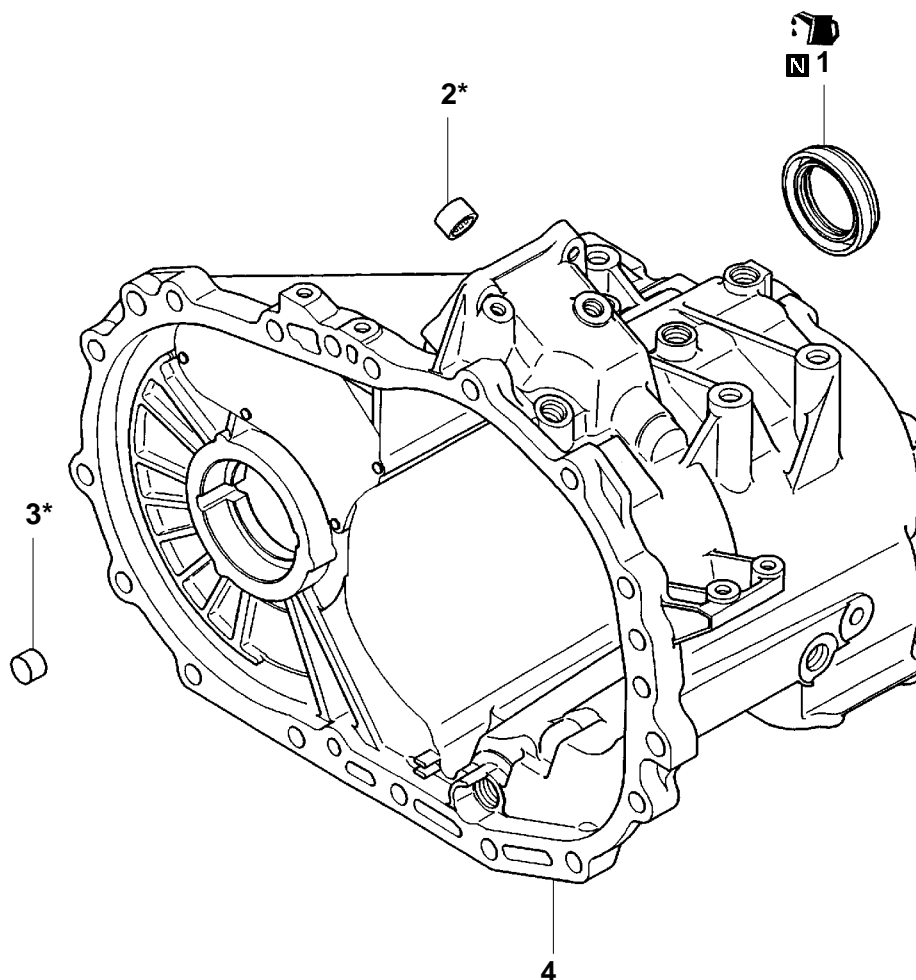

TFM0817

Disassembly steps

- ▶C◀ 1. Oil seal
- ▶B◀ 2. Needle bearing*
- ▶A◀ 3. Bushing*
- 4. Transmission case

NOTE:

*: Never remove the bearing and bushing from the transmission case.

Only the case when installing new bearing and bushing into a new transmission case, refer to ▶A◀ and ▶B◀.

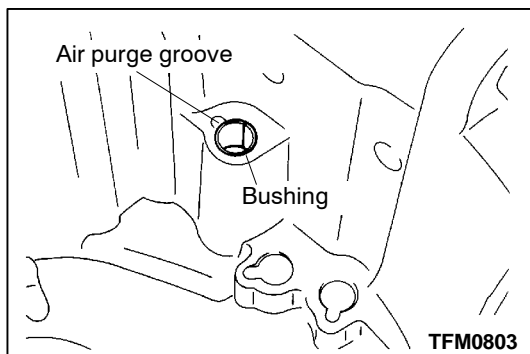

TFM0803

REASSEMBLY SERVICE POINTS

▶A◀ BUSHING INSTALLATION

Press fit the bushing to the illustrated position, while making sure that the split ends of the bushing do not coincide with the air purge groove.

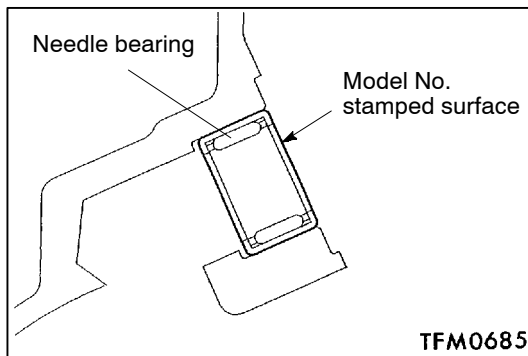
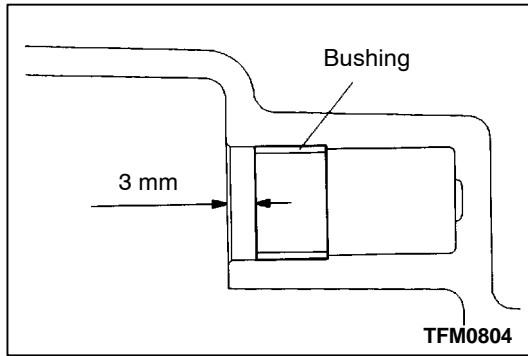

►B◄ NEEDLE BEARING INSTALLATION

Press fit the needle bearing until it is flush with the case, while making sure that the model number stamped side is oriented in the direction shown.

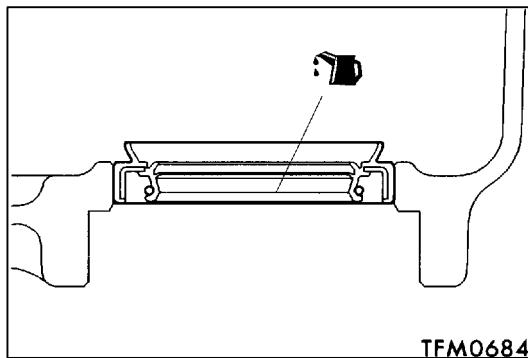

►C◄ OIL SEAL INSTALLATION

Apply transmission oil to the oil seal lip area.

Transmission oil:

Hypoid gear oil SAE 75W-85W conforming to API classification GL-4 or higher

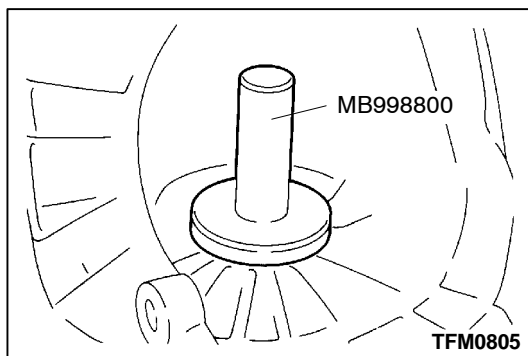

12. DIFFERENTIAL

DISASSEMBLY AND REASSEMBLY

 Apply gear oil to all moving parts before installation.

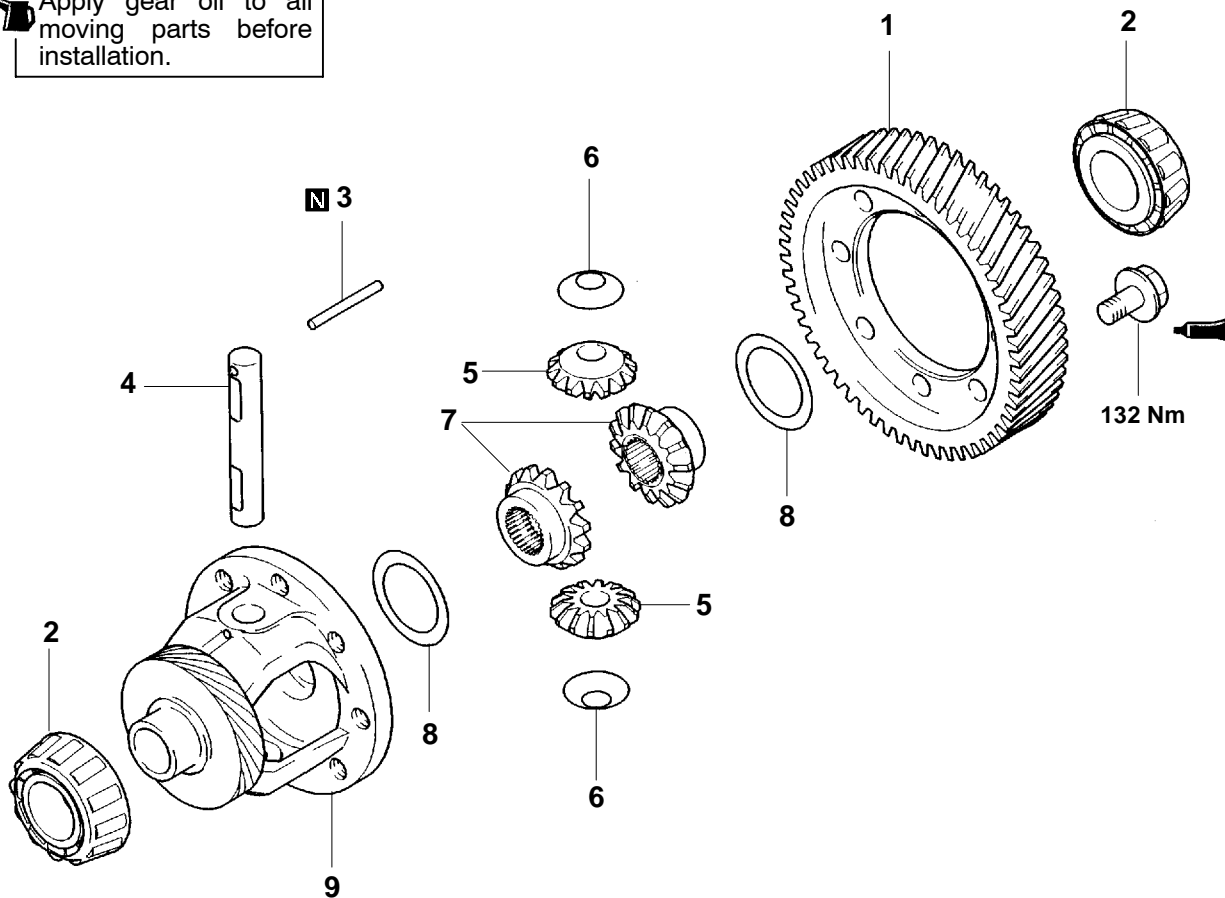

TFM0602

Disassembly steps

- ◀A▶ ▶D▶ 1. Differential drive gear
- ▶C▶ 2. Taper roller bearing
- ▶B▶ 3. Lock pin
- ▶A▶ 4. Pinion shaft
- ▶A▶ 5. Pinion
- ▶A▶ 6. Washer
- ▶A▶ 7. Side gear
- ▶A▶ 8. Spacer
- ▶A▶ 9. Differential case

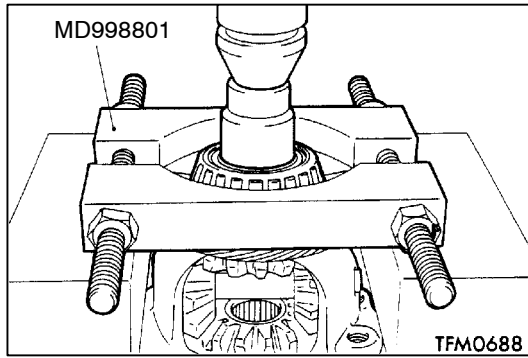
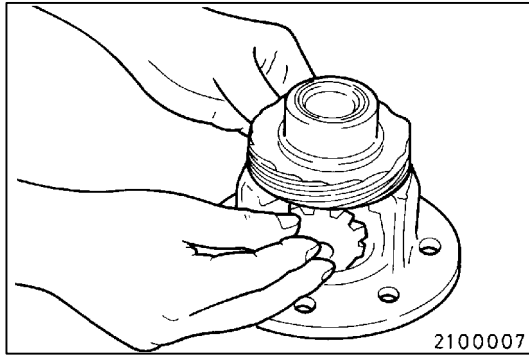
**DISASSEMBLY SERVICE POINT****◀A▶ TAPER ROLLER BEARING REMOVAL****REASSEMBLY SERVICE POINTS****▶A◀ SPACER / SIDE GEAR / WASHER / PINION / PINION SHAFT INSTALLATION**

- (1) After a spacer has been mounted on the back surface of the side gear, install the side gear in the differential case.

NOTE

When a new side gear is to be installed, mount a medium thickness spacer (0.8 or 0.9 mm).

- (2) Set the washer on the back of each pinion, and put both pinions simultaneously in mesh with the side gears. While rotating them, install them in position.

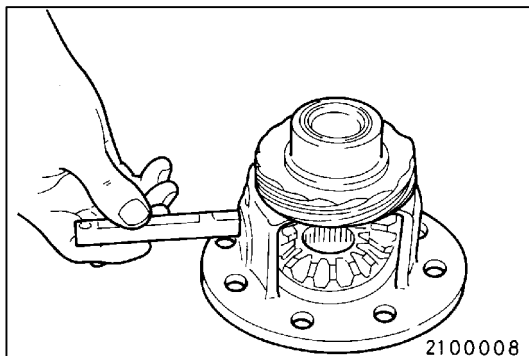

- (3) Insert the pinion shaft.

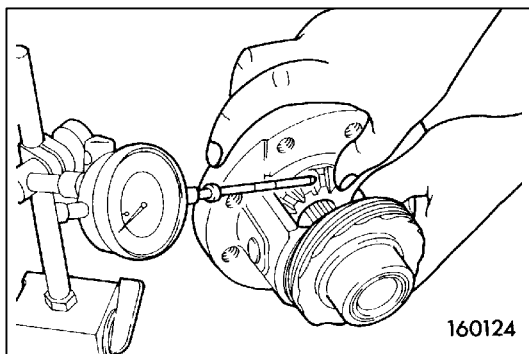

- (4) Measure the backlash between the side gear and pinion.
Standard value: 0.025 - 0.150 mm

- (5) If the backlash is out of specification, select a spacer and re-measure the backlash.

NOTE

Adjust until the backlashes on both sides are equal.

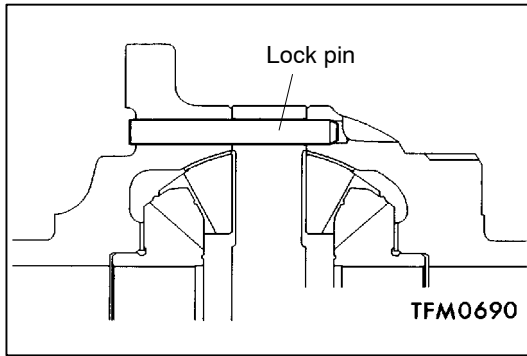

▶B◀ LOCK PIN INSTALLATION

Install the lock pin so that it will be oriented in the direction shown.

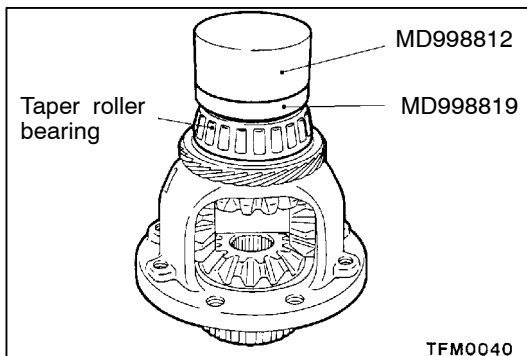

▶C◀ TAPER ROLLER BEARING INSTALLATION

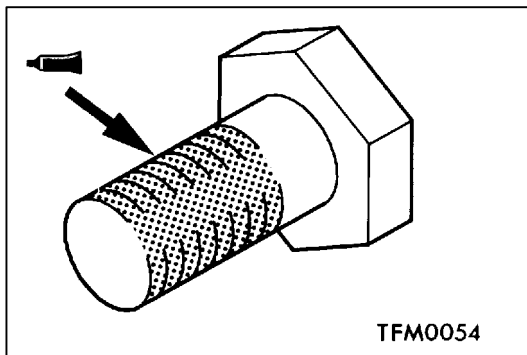

▶D◀ DIFFERENTIAL DRIVE GEAR INSTALLATION

(1) Apply a sealant to the entire threads of the bolt.

Specified sealant:

3M STUD Locking No. 4170 or equivalent

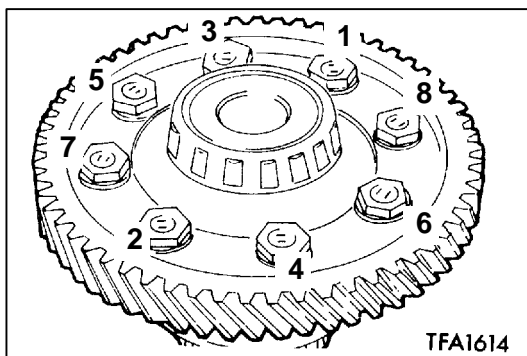

(2) Tighten to the specified torque in the illustrated sequence.