

MANUAL

TRANSMISSION

**MODEL F4M21, F5M21, F5M22,
F5M31, F5M33, W5M31 AND W5M33**

CONTENTS

GENERAL INFORMATION	22A- 0-3
1. SPECIFICATIONS	22A- 1-1
TRANSMISSION MODEL TABLE	22A- 1-1
GEAR RATIO TABLE	22A- 1-7
SERVICE SPECIFICATIONS	22A- 1-8
SEALANTS AND ADHESIVES	22A- 1-9
ADJUSTMENT SNAP RINGS AND SPACERS	22A-1-10
TORQUE SPECIFICATIONS	22A-1-18
2. SPECIAL TOOLS	22A- 2-1
3. TRANSMISSION	22A- 3-1
4. 5TH SPEED SYNCHRONIZER	22A- 4-1
5. INPUT SHAFT	22A- 5-1
6. INTERMEDIATE GEAR	22A- 6-1
7. OUTPUT SHAFT	22A- 7-1
8. FRONT OUTPUT SHAFT	22A- 8-1
9. DIFFERENTIAL	22A- 9-1
10. CENTER DIFFERENTIAL	22A-10-1
11. TRANSMISSION CASE ADAPTER	22A-11-1
12. SHIFT FORK	22A-12-1
13. SPEEDOMETER DRIVEN GEAR	22A-13-1
14. CLUTCH HOUSING	22A-14-1
15. TRANSFER	22A-15-1
16. EXTENSION HOUSING	22A-16-1
17. TRANSFER CASE	22A-17-1
18. TRANSFER CASE ADAPTER	22A-18-1
19. DRIVE BEVEL GEAR	22A-19-1
20. DRIVEN BEVEL GEAR	22A-20-1

GENERAL INFORMATION

MODEL F4M21 – FOUR SPEED FRONT WHEEL DRIVE TRANSMISSION

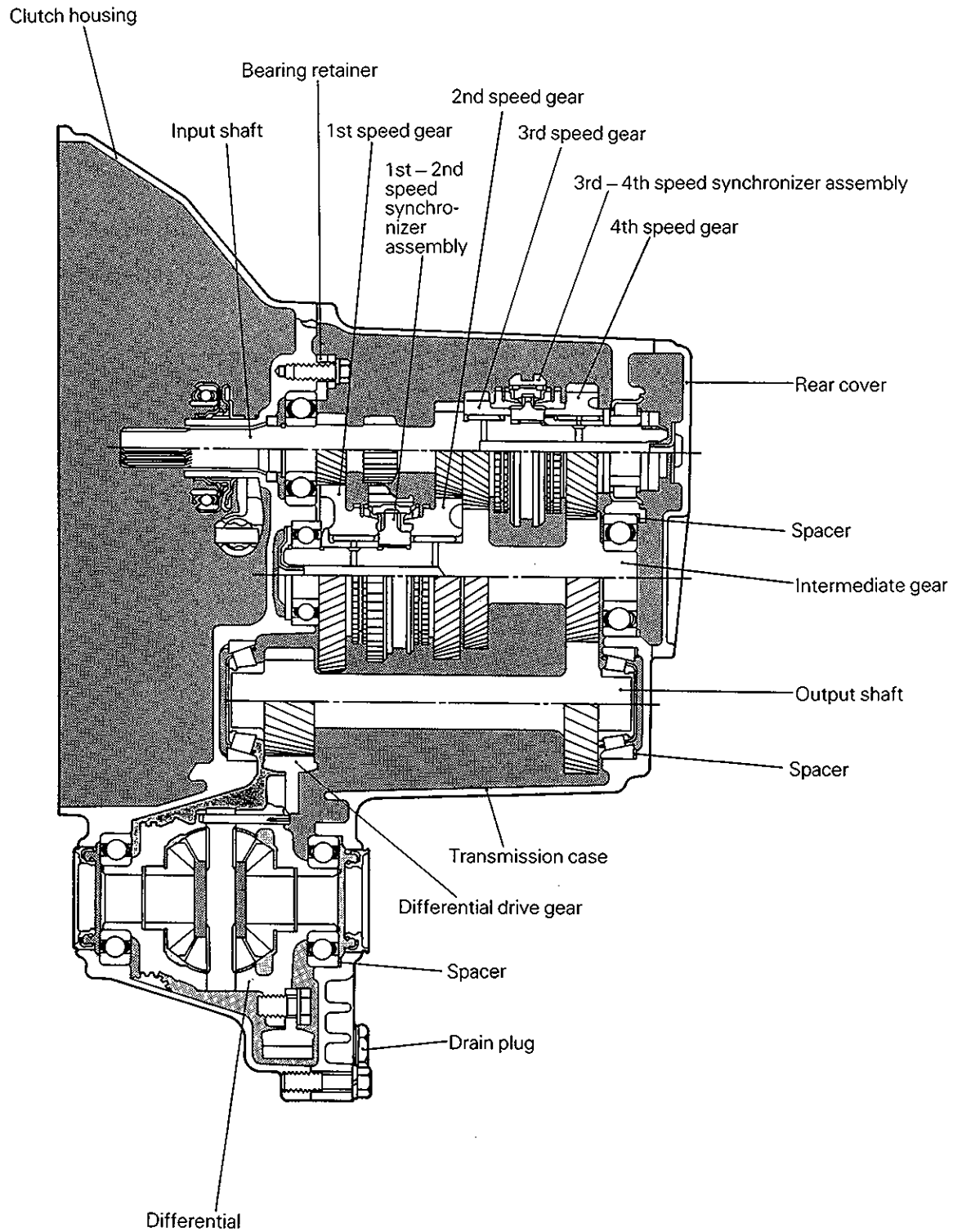

MODEL F5M21 – FIVE SPEED FRONT WHEEL DRIVE TRANSMISSION

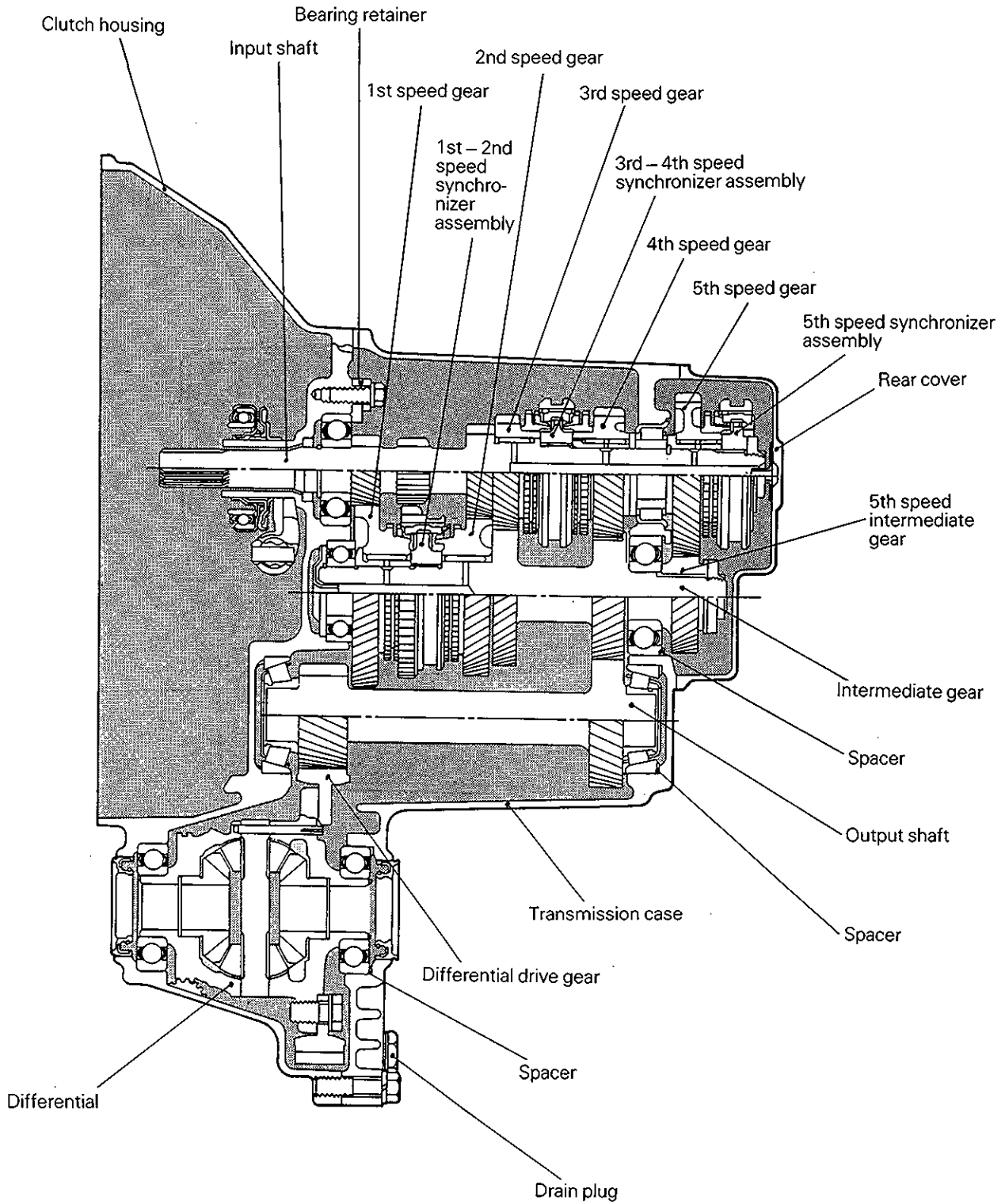

MODEL F5M22 -- FIVE SPEED FRONT WHEEL DRIVE TRANSMISSION

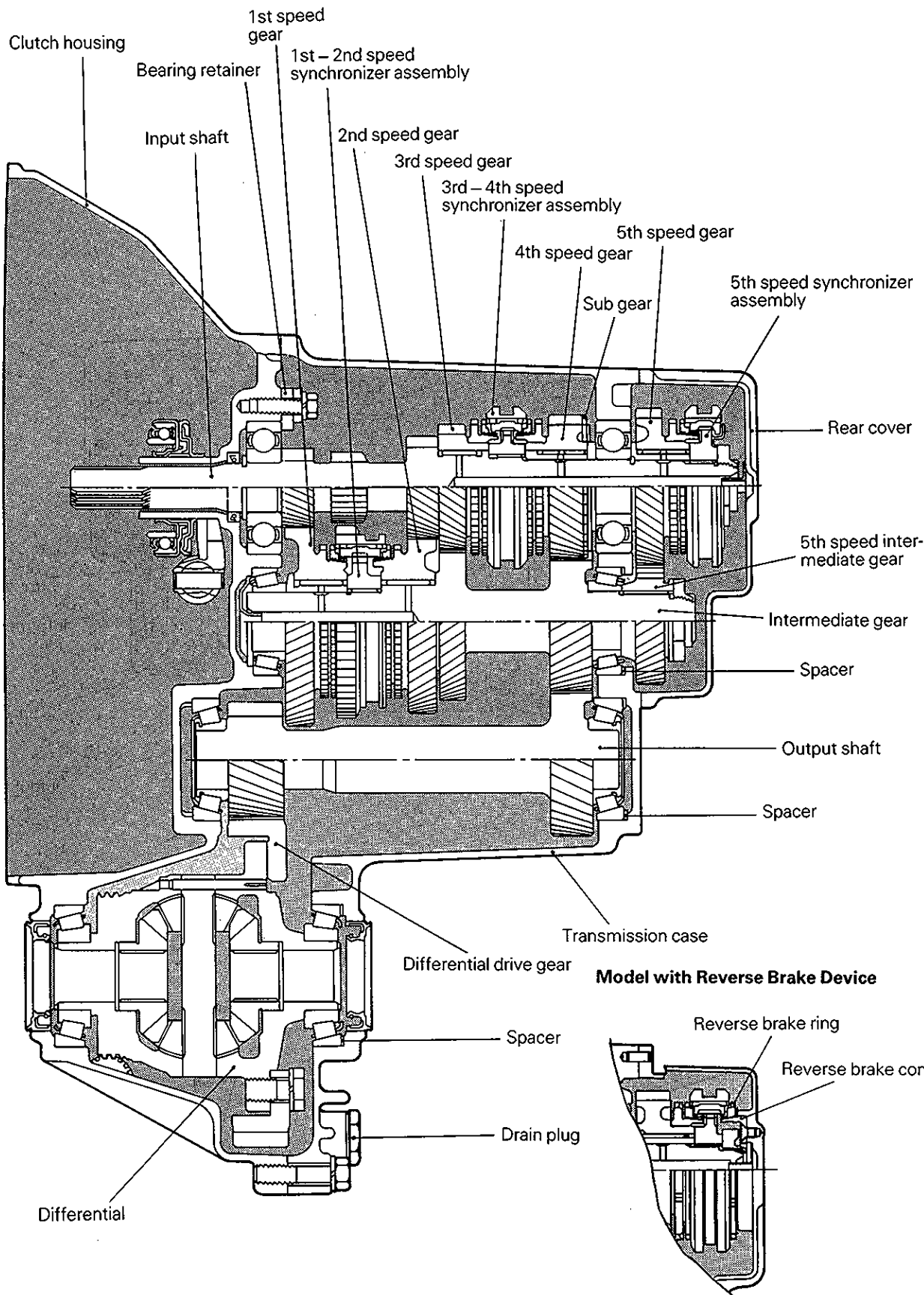

TFM0108
2060021

MODEL F5M31 – FIVE SPEED FRONT WHEEL DRIVE TRANSMISSION

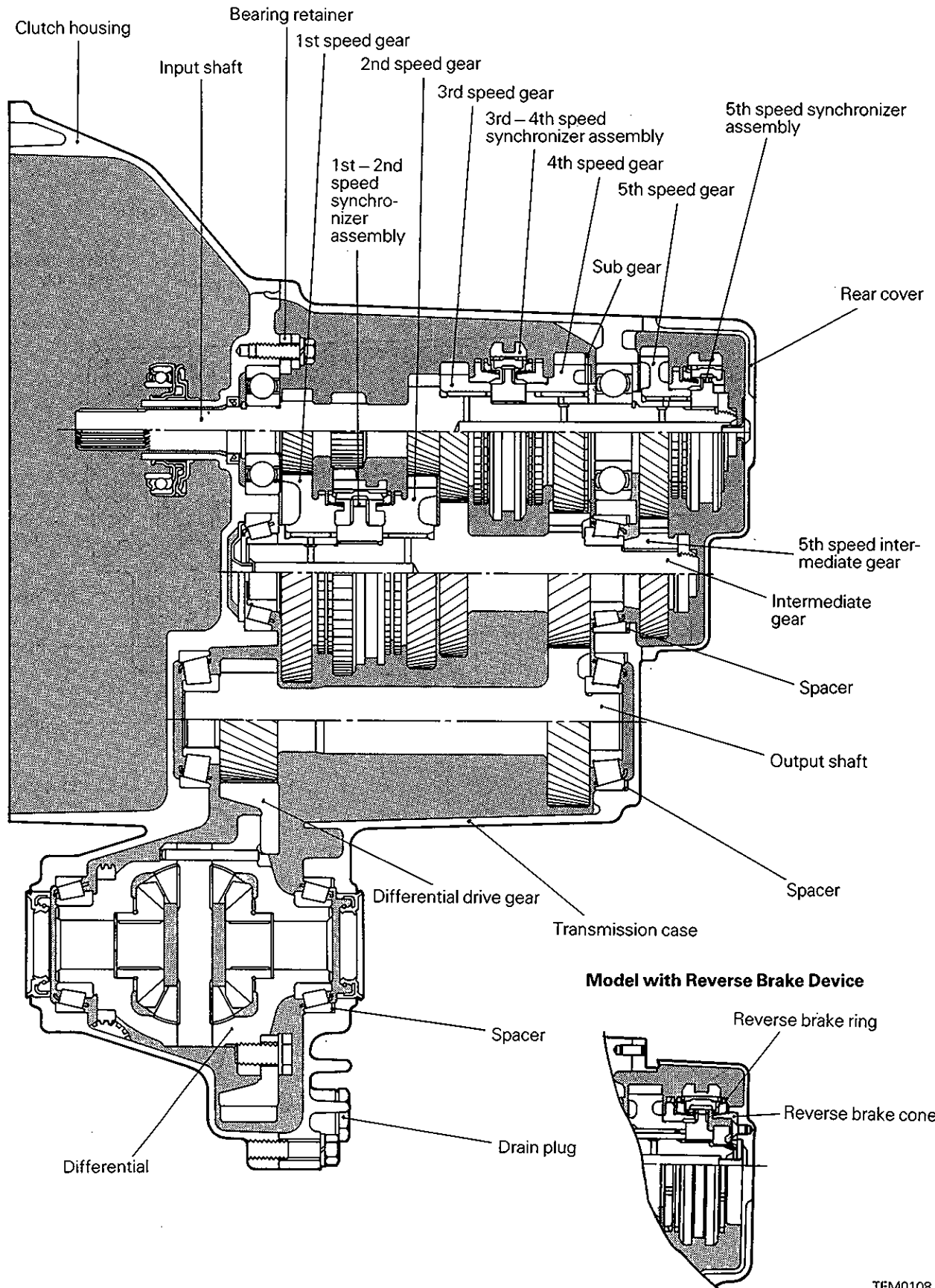

TFM0108
2100031

MODEL F5M33 – FIVE SPEED FRONT WHEEL DRIVE TRANSMISSION

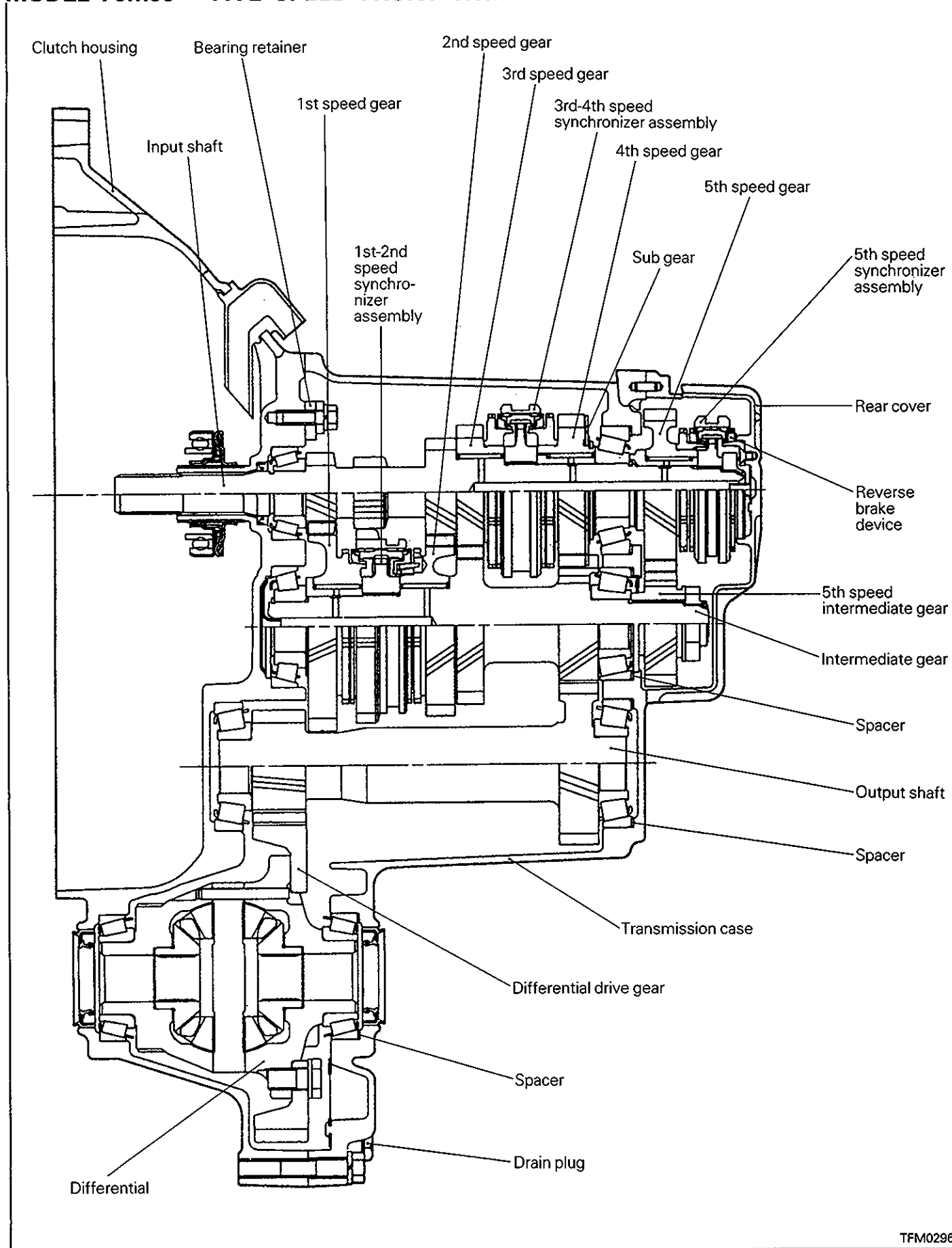

TFM0296

Intentionally blank

MODEL W5M31 – FIVE SPEED FOUR WHEEL DRIVE TRANSMISSION WITH DIFFERENTIAL LOCK

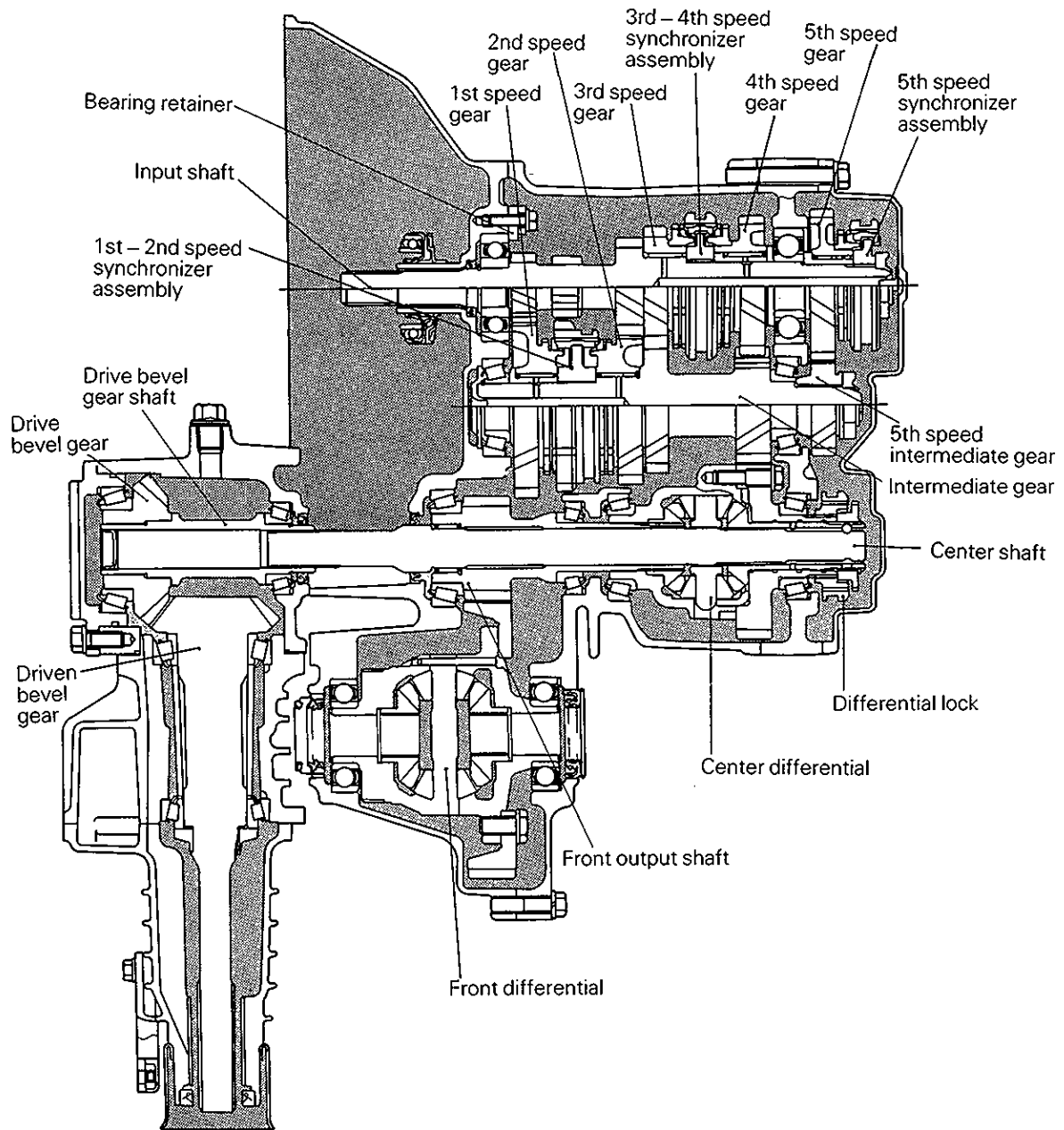

MODEL W5M31 – FIVE SPEED FOUR WHEEL DRIVE TRANSMISSION WITH VISCOUS COUPLING

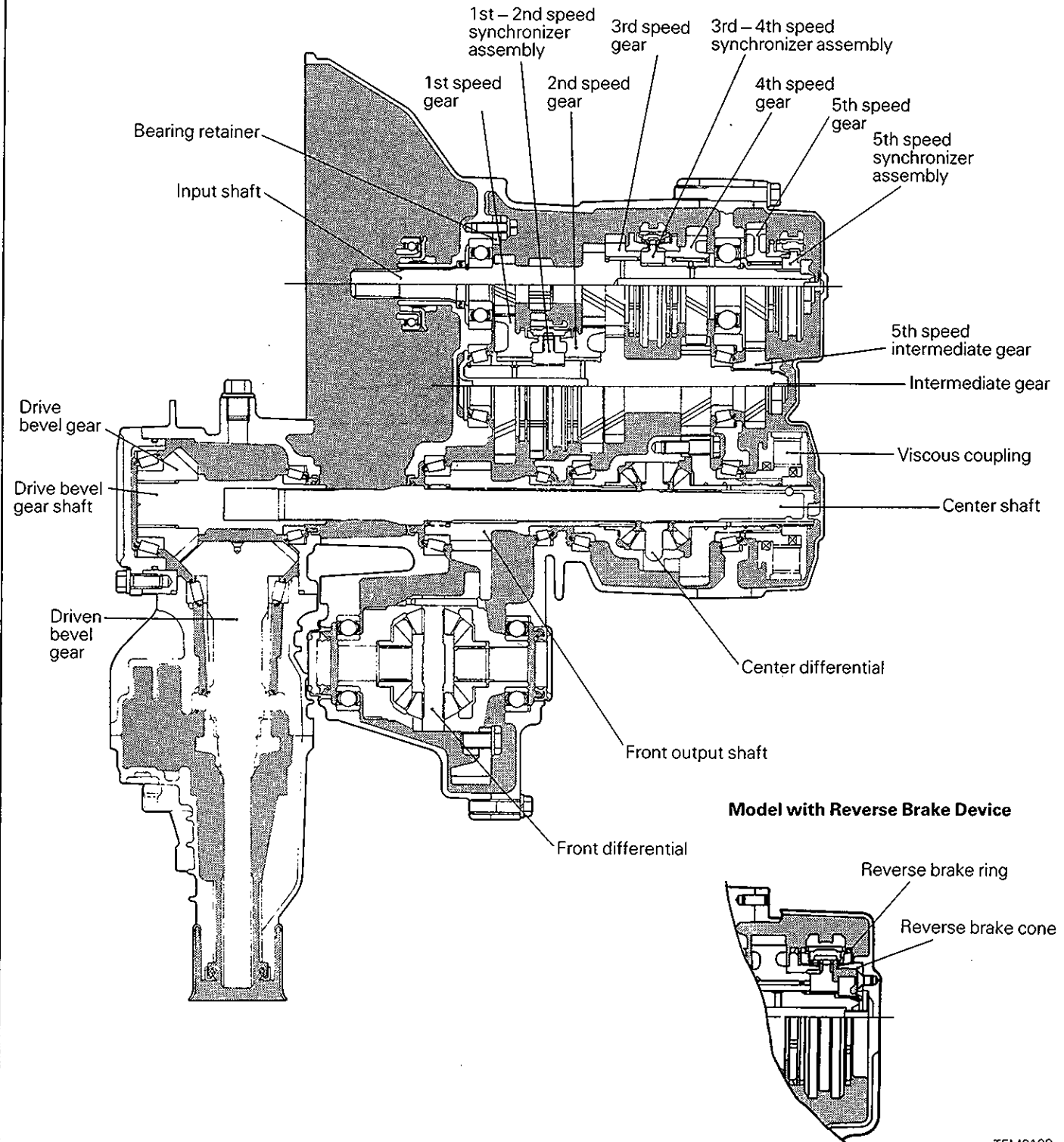

TFM0108
2210116

MODEL W5M33 – FIVE SPEED FOUR WHEEL DRIVE TRANSMISSION WITH VISCOUS COUPLING

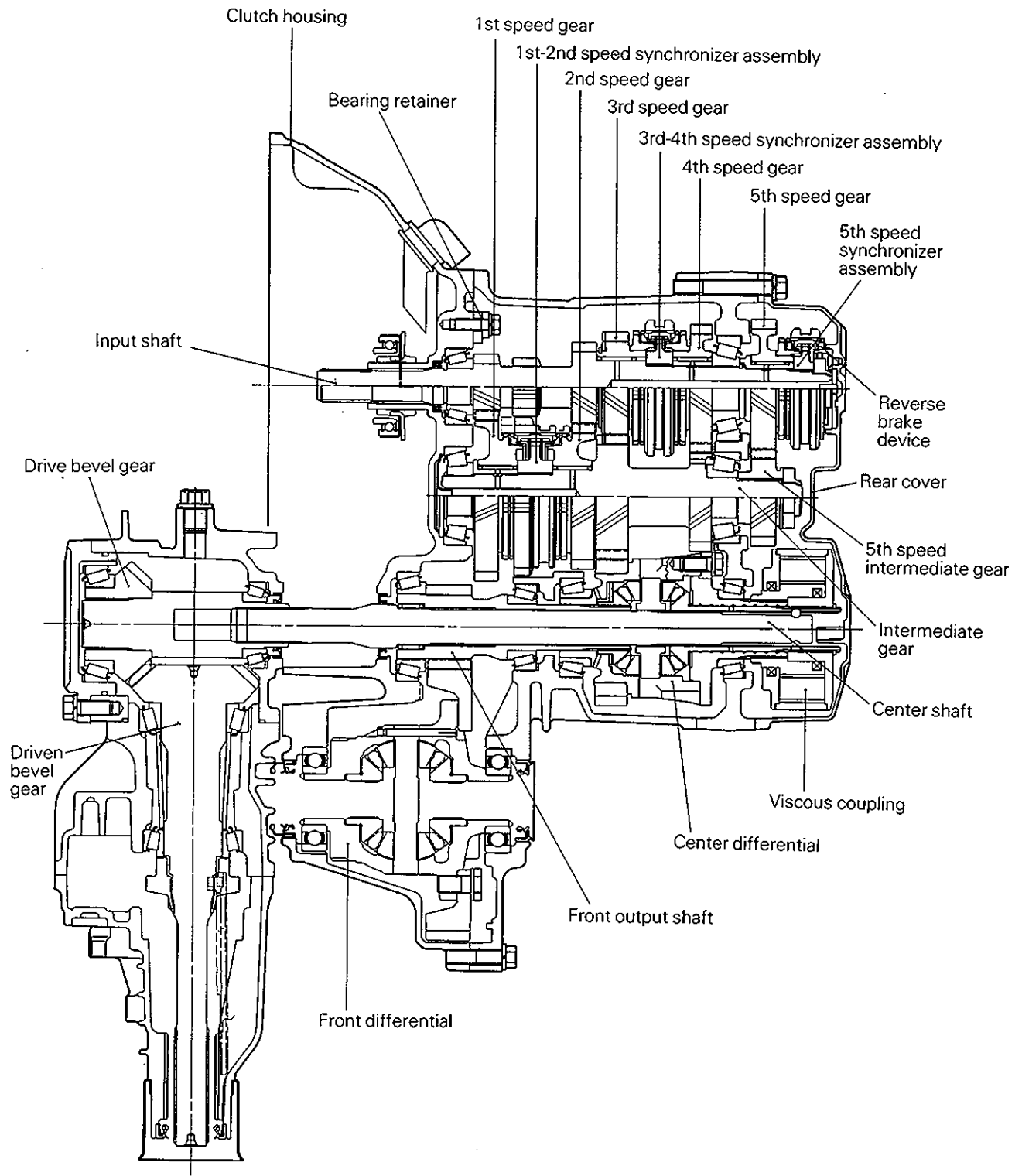

LIST OF MAJOR CHANGES

	Description of Change	Applicable Transmission Model	Effective Date
①	Output shaft bearing changed from ball bearing to taper roller bearing.	F4M21, F5M21	From July 1987
②	Synchronizer spring and synchronizer key changed it shape.	All models	From Sept. 1987
③	Synchronizer ring diameter reduced by 1 mm (0.04 in.).	All models	From Oct. 1987
④	Tooth width of 5th speed gear increased by 3 mm (0.12 in.).	F5M21, F5M22	From Nov. 1987
⑤	Input shaft snap ring added.	5-speed model only	From Dec. 1987
⑥	3rd-4th speed synchronizer sleeve & key, 5th speed synchronizer sleeve key and rear cover changed.	All models	From Nov. 1988
⑦	Reverse brake device added.	5-speed model only	From Jan. 1989
⑧	1st-2nd speed synchronizer spring changed in shape.	All models	From Nov. 1989
⑨	Filter added to intermediate rear bearing.	W5M31 for EC only	From Jan. 1990

1. SPECIFICATIONS

TRANSMISSION MODEL TABLE – MODEL 1987

	Transmission model	Gear ratio	Speedometer gear ratio	Final gear ratio	Vehicle model	Engine model	
EC	KM200-0-DL	A	32/36	4.322	C15A	4G16	
	KM201-0-C	B	31/36	4.021	E11A	4G32	
	CL	D	32/36	4.021	C11A, C12A	4G13, 4G15	
	CN	B	29/36	4.021	E11A, E15A	4G32, 4G63	
	DL	D	32/36	4.322	C15A, C12V	4G15, 4G16	
	KM206-0-AQL	B	31/36	4.021	C14A	4D65	
	C	B	31/36	4.021	E15A	4G63	
	CKQL	D	31/36	4.021	C13A	4G32 Turbo	
	CN	B	29/36	4.021	E15A	4G63	
	CP	B	30/36	4.021	E15A	4G63	
	FKL	B	32/36	4.021	C14V	4D65	
	KM210-0-A	F	31/36	4.067	E16A	G64B	
	AQL	I	31/36	4.067	C13A	4G32 Turbo	
	MCKN	G	29/36	4.471	E14A	4D65 Intercooler Turbo	
	MCKP	H	29/36	4.471	E14A	4D65 Intercooler Turbo	
	KM220-0-JN	K	29/36	5.084	C37	4G37, G37B	
	J	J	31/36	5.084	C37	4G37, G37B	
	EXP	KM200-0-C	A	31/36	4.021	E11A	4G32
		CL	A	32/36	4.021	C11A	4G13
		DQL	A	31/36	4.322	C11V	4G13
KM201-0-C		B	31/36	4.021	E11A, E12A	4G32, 4G37	
CL		D	32/36	4.021	C11A, C12A	4G13, 4G15	
CP		B	30/36	4.021	E12A	4G37	
DL		D	32/36	4.322	C11V, C12V	4G13, 4G15	
KM206-0-AKL		B	32/36	3.752	C14A	4D65	
CN		B	29/36	4.021	E15A	4G63	
CP		B	30/36	4.021	E15A	4G63	
KM210-0-AQL		I	30/36	4.067	C13A	4G32 Turbo	
KM220-0-J		J	31/36	5.084	C37	4G37	

NOTE

For the gear ratio, refer to the GEAR RATIO TABLE on page 22A-1-7.

TRANSMISSION MODEL TABLE – MODEL 1988

	Transmission model	Gear ratio	Speedometer gear ratio	Final gear ratio	Vehicle model	Engine model
EC	KM200-0-DL	A	32/36	4.322	C15A	4G16
	KM201-0-CL	D	32/36	4.021	C11A, C12A	4G13, 4G15
	CPH	B	30/36	4.021	E31A	4G32
	CZ	C	31/36	4.021	D05V, D05W	4G37
	DL	D	32/36	4.322	C15A, C12V	4G15, 4G16
	KM206-0-CKNH	B	29/36	4.021	E33A	4G63
	CKPH	B	30/36	4.021	E33A	4G63
	CKQL	D	31/36	4.021	C13A	4G32 Turbo
	CKZ	C	31/36	4.021	D09V, D09W	4D65 Turbo
	DNH	B	29/36	4.322	E32A	4G37
	EKPH	E	30/36	4.592	E33A	4G63 DOHC
	FKL	B	32/36	4.021	C14V	4D65
	KM210-0-BN	I	29/36	4.322	E16A	4G64
	MCNH	H	29/36	4.471	E34A	4D65 Turbo
	KM220-0-JN	J	J	29/36	5.084	C37V
J		J	31/36	5.084	C37V	4G37, G37B
EXP	KM200-0-CL	A	32/36	4.021	C11A	4G13
	DQL	A	31/36	4.322	C11V	4G13
	KM201-0-AKL	D	32/36	3.752	C14V	4D65
	CL	D	32/36	4.021	C11A, C12A	4G13, 4G15
	CP	B	30/36	4.021	E12A	4G37
	CPH	B	30/36	4.021	E31A	4G32
	CZ	C	31/36	4.021	D04W	4G37
	DL	D	32/36	4.322	C11V, C12V	4G13, 4G15
	KM206-0-AKQL	B	31/36	3.752	C14A	4D65
	CKNH	B	29/36	4.021	E33A	4G63
	CKTX	B	30/36	4.021	E15A	4G63
	CNH	B	29/36	4.021	E33A	4G63
	DNH	B	29/36	3.941	E31A, E32A	4G32, 4G37
	EKPH	E	30/36	4.187	E33A	4G63 DOHC
	KM210-0-AP	F	30/36	4.067	E16A	4G64
KM220-0-J	J	31/36	5.084	C37V	4G37	
AUS	KM206-0-CZ	C	31/36	4.021	D04W	4G63

NOTE

DOHC: Double overhead camshaft

For the gear ratio, refer to the GEAR RATIO TABLE on page 22A-1-7.

TRANSMISSION MODEL TABLE – MODEL 1989

	Transmission model	Gear ratio	Speedometer gear ratio	Final gear ratio	Vehicle model	Engine model
EC	KM200-0-CQL	A	31/36	4.021	C51A, C61A	4G13
	KM201-0-CL	D	32/36	4.021	C12A	4G15
	CKQL	D	31/36	4.021	C52A, C62A	4G15
	CQL	D	31/36	4.021	C51A, C52A, C62A	4G13, 4G15
	CQL1	D	31/36	4.021	C51A, C52A, C62A	4G13, 4G15
	CZ	C	31/36	4.021	D05V, D05W	4G37
	DKRL	D	32/36	4.322	C12V	4G15
	DL	D	32/36	4.322	C12V	4G15
	KM206-0-AJOK	B	31/36	3.752	C54A, C64A	4D65
	CKZ	C	31/36	4.021	D04W	4G63
	EKQL (EJQL)*	E	31/36	4.592	C53A, C63A	4G61 DOHC
	EKL	B	32/36	4.021	C14V	4D65
	KM210-0-BN*	I	29/36	4.322	E16A	4G64
	KM220-1-JN	K	29/36	5.084	C37V	4G37
	KM221-1-CNH*	L	29/36	5.208	E38A, E39A	4G63
CPH*		L	30/36	5.208	E38A, E39A	4G63 DOHC
EXP	KM200-0-DQL	A	31/36	4.322	C11V	4G13
	KM201-0-AKQL	B	31/36	3.752	C54A, C64A	4D65
	CL	D	32/36	4.021	C11A, C12A	4G13, 4G15
	CKQL	D	31/36	4.021	C62A	4G15
	CQL	D	31/36	4.021	C51A, C52A, C61A, C62A	4G13, 4G15
	CQL1	D	31/36	4.021	C51A, C61A	4G13
	CZ	C	31/36	4.021	D05W	4G37
	DL	D	32/36	4.322	C11V, C12V	4G13, 4G15
	KM206-0-AKQL	D	31/36	3.752	C64A	4D65
	EKQL (EJQL)*	E	30/36	4.187	C53A, C63A	4G61 DOHC
	KM220-1-JN	K	29/36	5.084	C37V	4G37
AUS	KM201-0-CQL1	D	31/36	4.021	C64A	4D65
	KM206-0-CZ	C	31/36	4.021	D04W	4G63

NOTE

DOHC: Double overhead camshaft

For the gear ratio, refer to the GEAR RATIO TABLE on page 22A-1-7.

*: Model with reverse brake device.

TRANSMISSION MODEL TABLE – MODEL 1990

	Transmission model	Gear ratio	Speedometer gear ratio	Final gear ratio	Vehicle model	Engine model
EC	F4M21-1-RRAC	A	31/36	4.021	C15A, C15V	4G13
	VRAC	A	31/36	4.322	C15A, C15V	4G13
	F5M21-1-RRAC	D	31/36	4.021	C51A, C61A	4G13
	RRBC	D	31/36	4.021	C51A, C61A	4G13
	RRJC	D	31/36	4.021	C52A, C62A	4G15
	VRAC	D	31/36	4.322	C12V, C65A	4G15, 4G16
	VRJC	D	31/36	4.322	C12V	4G15
	RRAN	C	31/36	4.021	D05W, D05V	4G37
	RQAH	B	30/36	4.021	E31A	4G32
		F5M22-1-VPKH	B	29/36	4.322	E32A
VQKH		B	30/36	4.322	E32A	4G37
FRKC		B	31/36	3.752	C54A, C64A	4D65
RRKN		C	31/36	4.021	D09W, D09V	4D65 Turbo
RRMC		B	31/36	4.021	C14V	4D65
2-XRZC*		E	31/36	4.592	C53A, C63A	4G61 DOHC
F5M31-2-VPKY*		G	29/36	4.322	E16A	4G64
W5M31-1-SPAC		K	29/36	5.084	C37V	4G37
	2-SRBC*	K	31/36	5.084	C77A	4G37
	VPZH*	M	29/36	5.084	E39A	4G63
EXP	F4M21-1-RRAC	A	31/36	4.021	C61A	4G13
	VRAC	A	31/36	4.322	C11V	4G13
	F5M21-1-RRAC	D	31/36	4.021	C51A, C52A, C61A, C62A	4G13, 4G15
	RRBC	D	31/36	4.021	C15A, C52A, C61A, C62A	4G13, 4G15
	RRCC	D	31/36	4.021	C52A, C62A	4G15
	RRJC	D	31/36	4.021	C52V, C62A	4G15
	VRAC	D	31/36	4.322	C11V, C12V	4G13, 4G15
	FRJC	B	31/36	3.752	C54A, C64A	4D56
	F5M22-1-VPAH		B	29/36	4.322	E32A
RPAH		B	29/36	4.021	E33A	4G63
FDTC		B	31/36	3.752	C64A	4D56
RCKY		B	30/36	4.021	E15A	4G63
2-XRZC*		E	31/36	4.592	C53A, C63A	4G61 DOHC
XQZH*		E	30/36	4.592	E33A	4G63 DOHC
F5M31-2-RQKY*	I	30/36	4.067	E16A	4G64	
W5M31-1-SPAC	K	29/36	5.084	C37V	4G37	
AUS	F5M21-1-RRBC	D	31/36	4.021	C62A	4G15
	RRJC	D	31/36	4.021	C52A, C62A	4G15
F5M22-1-RRAN	C	31/36	4.021	D04W	4G63	

NOTE

DOHC: Double overhead camshaft

For the gear ratio, refer to the GEAR RATIO TABLE on page 22A-1-7.

*: Model with reverse brake device.

TRANSMISSION MODEL TABLE – MODEL 1991

Transmission model	Gear ratio	Speedometer gear ratio	Final gear ratio	Vehicle model	Engine model
EC F5M21-1-VRAC	D	31/36	4.322	C12V, C15V, C65A	4G13, 4G15, 4G16
VRJC	D	31/36	4.322	C12V	4G15
VRLC	E	31/36	4.322	C52A, C62A	4G15
VRDC	E	31/36	4.322	C52A, C62A	4G15
RRJC	D	31/36	4.021	C52A, C62A	4G15
VRBC	D	31/36	4.322	C51A, C61A	4G13
XRAC	D	31/36	4.592	C51A, C61A	4G13
RRAC	C	31/36	4.021	D05V, D05W	4G37
RQAK	B	30/36	4.021	E31A	4G32
RQAH	B	30/36	4.021	E31A	4G32
F5M22-1-RRMC	B	31/36	4.021	C14V	4D65
FRKC	B	31/36	3.752	C54A, C64A	4D65
RRKN	C	31/36	4.021	D04W, D09V, D09W	4D65 Turbo
VPK	B	29/36	4.322	E32A	4G37
VRKK	B	29/36	4.322	E32A	4G37
VQKK	B	30/36	4.322	E32A	4G37
RPKK	B	29/36	4.021	E33A	4G63
2-XRKC	E	31/36	4.592	C58A, C68A	4G67 DOHC
XPZK	E	29/36	4.592	E33A	4G63 DOHC
F5M31-1-WPMK	H	29/36	4.471	E34A	4G63 Turbo
F5M33-2-SNZ	J	28/36	4.153	F16A	6G72, 6G72 DOHC
W5M31-1-SPAC	K	29/36	5.084	C37V	4G37
SPBC	K	29/36	5.084	C37V	4G37
2-SRBC	K	31/36	5.084	C87A	4G37
VPXK	L	29/36	5.208	E39A	4G63
VQXK	L	30/36	5.208	E39A	4G63
VPZK	M	29/36	5.208	E39A	4G63 DOHC

NOTE
DOHC: Double overhead camshaft

TRANSMISSION MODEL TABLE – MODEL 1991

Transmission model	Gear ratio	Speedometer gear ratio	Final gear ratio	Vehicle model	Engine model
EXP F4M21-1-VRAC	A	31/36	4.322	C11V	4G13
	RRAC	A	31/36	C61V	4G13
F5M21-1-VRAC	D	31/36	4.322	C11A, C12V, C51A, C61A	4G13, 4G15
VRBC	D	31/36	4.322	C51A, C61A	4G13
VRLC	E	31/36	4.322	C52A, C62A	4G15
VRDC	E	31/36	4.322	C52A, C62A	4G15
XRUC	E	31/36	4.322	C52A, C62A	4G15
RRJC	D	31/36	4.021	C62A	4G15
FRJC	B	31/36	3.752	C64A	4D65
ROAK	B	30/36	4.021	E31A	4G32
F5M22-1-FRKC	B	31/36	3.752	C54A	4D65
FDTC	B	31/36	3.752	C64A	4D65
RCKY	B	30/36	4.021	E15A	4G63
VPAK	B	29/36	4.322	E32A	4G37
RPAK	B	29/36	4.021	E33A	4G63
RPKK	B	29/36	4.021	E33A	4G63
2-XRZC	E	31/36	4.592	C58A, C68A	4G67 DOHC
XQZK	E	30/36	4.592	E33A	4G63 DOHC
F5M33-2-SNZ	J	28/36	4.153	F16A	6G72, 6G72 DOHC
W5M31-1-SPAC	K	29/36	5.084	C37V	4G37
W5M33-2-NOZK	N	30/36	4.933	E39A	4G63 DOHC Intercooler Turbo
MMAL F5M21-1-VRXC	E	31/36	4.322	C52A, C62A	4G15
	1-VRDC	E	31/36	C62A	4G15
F5M22-1-RPKK	B	29/36	4.021	E33A	4G63
2-ZRZC	E	31/36	4.592	C53A	4G61 DOHC
XQZK	E	30/36	4.592	E33A	4G63 DOHC
W5M33-2-NOZK	N	30/36	4.933	E39A	4G63 DOHC Intercooler Turbo

NOTE
DOHC: Double overhead camshaft

TRANSMISSION MODEL TABLE – MODEL 1992

Transmission model	Gear ratio	Speedometer gear ratio	Final gear ratio	Vehicle model	Engine model
EC F5M21-1-RQAK	B	30/36	4.021	E31A	4G32
VRAE	E	31/36	4.021	CA1A	4G13
VRJE	E	31/36	4.021	CA1A	4G13
2-XPZK	D	29/36	4.592	E33A	4G63 DOHC
F5M22-1-RPKK	B	29/36	4.021	E33A	4G63
RQKK	B	30/36	4.021	E33A	4G63
VPAK	B	29/36	4.322	E32A	4G37
VPAK	B	29/36	4.322	E32A	4G37
VQKK	B	30/36	4.322	E32A	4G37
VRKK	B	31/36	4.322	E32A	4G37
XPXL	B	29/36	4.592	N11W, N31W	4G93
2-RRXE	B	31/36	4.021	CA4A	4G92
VRZE	B	31/36	4.322	CA5A	4G93 DOHC
XPZK	B	29/36	4.592	E33A	4G63 DOHC
F5M31-1-WPMK	H	29/36	4.471	N35W	4D65 Turbo
ZPXZ	K	29/36	4.913	E34A	4D65 Turbo
F5M33-2-SNEJ	J	28/36	4.153	F16A	6G72 DOHC
SNQJ	J	28/36	4.153	F16A	6G72
W5M31-2-VPLK	O	29/36	5.208	E39A	4G63 DOHC
VPXK	O	29/36	5.208	E38A, E39A	4G63
VPXL	M	29/36	5.208	N21W, N41W	4G93
VQXK	O	30/36	5.208	E38A, E39A	4G63
VRCE	M	31/36	5.208	CC4A	4G92

NOTE
DOHC: Double overhead camshaft

Transmission model	Gear ratio	Speedometer gear ratio	Final gear ratio	Vehicle model	Engine model
EXP F5M21-1-RQAK	B	30/36	4.021	E31A	4G32
RRAE	B	31/36	4.021	CB1A	4G13
RRAE	B	31/36	4.021	CA2A, CB2A	4G15
RRBE	B	31/36	4.021	CA2A, CB2A	4G15
VRAE	E	31/36	4.322	CA1A, CB1A	4G13
VRBE	E	31/36	4.322	CA1A, CB1A	4G13
VRJE	E	31/36	4.322	CB1A	4G13
F5M22-1-FDTE	B	31/36	3.752	CB8A	4D68
FRME	B	31/36	3.752	CB8A	4D68
RPAK	B	29/36	4.021	E33A	4G63
RPKK	B	29/36	4.021	E33A	4G63
VPAK	B	29/36	4.322	E32A, E33A	4G37
VQKK	B	30/36	4.322	E32A	4G37
VRKK	B	31/36	4.322	E32A	4G37
XPLL	B	29/36	4.592	N11W, N31W	4G93
XPXL	B	29/36	4.592	N11W, N31W	4G93
2-RRXE	B	31/36	4.021	CA4A	4G92
VRZE	B	31/36	4.322	CA5A	4G93 DOHC
XQZK	B	30/36	4.592	E33A	4G63 DOHC
F5M31-2-ZOZK	K	30/36	4.913	E33A	4G63 DOHC
F5M33-2-SNQJ	J	28/36	4.153	F16A	6G72, 6G72 DOHC
W5M33-2-NOBM	Q	30/36	4.933	E39A	4G63 DOHC Intercooler Turbo
NOZK	Q	30/36	4.933	E39A	4G63 DOHC Intercooler Turbo
NOZM	Q	30/36	4.933	E39A	4G63 DOHC Intercooler Turbo
AUS F5M21-1-RRBE	B	31/36	4.021	CA2A, CB2A	4G15
F5M22-1-RPKK	B	29/36	4.021	E33A	4G63
2-RRKE	B	31/36	4.021	CA5A, CB5A	4G93
XQZK	B	30/36	4.592	E33A	4G63 DOHC
F5M31-2-RPKJ	K	29/36	4.067	F06W	4G54
VPXZ	K	29/36	4.322	N31W	4G64
F5M33-2-SNZJ	J	28/36	4.153	F07W	6G72
W5M33-2-NOZK	Q	30/36	4.933	E39A	4G63 DOHC Intercooler Turbo

NOTE
DOHC: Double overhead camshaft

TRANSMISSION MODEL TABLE – MODEL 1993

Transmission model	Gear ratio	Speedometer gear ratio	Final gear ratio	Vehicle model	Engine model	
EC F5M21-1-VRAA	E	31/36	4.322	C61A	4G13	
	VRAC	E	31/36	4.322	C61A	4G13
	VRAE	E	31/36	4.322	CB1A	4G13
	VRJE	E	31/36	4.322	CB1A	4G13
	VRLC	E	31/36	4.322	C62A	4G15
F5M22-1-FRMA	B	31/36	3.752	C67A	4D68	
	FRME	B	31/36	3.752	CB8A, CB8W	4D68
	FRMG	B	31/36	3.752	CB8A, CB8W	4D68
	XPXL	B	29/36	4.592	N33W	4G63
	XPZL	B	29/36	4.592	N11W	4G93
	2-RRGE	B	31/36	4.021	CB4W	4G92
	RRXA	B	31/36	4.021	C66A	4G92
	RRZE	B	31/36	4.021	CB4A	4G92
	VPZF	B	29/36	4.322	E52A	4G93
	VQKF	B	30/36	4.322	E55A	4G63
	VRXA	B	31/36	4.322	C69A	4G93
	VRXE	B	31/36	4.322	CB5A	4G93
	F5M31-1-VPMF	K	29/36	4.322	E57A	4D68 Turbo
ZPMF		K	29/36	4.913	N18W, N38W	4D68 Turbo
2-ZPEF		K	29/36	4.913	E54A, E64A	6A12 DOHC
ZPVF		K	29/36	4.913	E54A, E64A	6A12 DOHC
ZPXF		K	29/36	4.913	E54A	6A12 DOHC
ZPXV		K	29/36	4.913	D22A	4G63 DOHC
F5M33-2-SNEJ	J	28/36	4.153	F16A	6G72 DOHC	
	SNXJ	J	28/36	4.153	F16A	6G72
W5M31-2-VPCE	M	29/36	5.208	CD4W	4G92	
	VPXL	M	29/36	5.208	N21W	4G93
	VPXL	O	29/36	5.208	N43W	4G63
	VQBF	O	30/36	5.208	E75A	4G63
	VRCE	M	31/36	5.208	CD4A	4G92
	ZRCA	M	31/36	5.433	C76A	4G92
W5M33-2-WPBV	Q	29/36	5.443	D27A	4G63 DOHC Intercooler Turbo	
	WPXF	Q	29/36	5.443	E88A	6G73 DOHC

NOTE
DOHC: Double overhead camshaft

Transmission model		Gear ratio	Speedometer gear ratio	Final gear ratio	Vehicle model	Engine model
EXP	F5M21-1-RRAE	B	31/36	4.021	CA2A, CB2A	4G15
	VRAE	E	31/36	4.322	CA1A, CB1A, CB2A	4G13
	VRBE	E	31/36	4.322	CB1W, CB2W	4G13
	VRGA	E	31/36	4.322	C62A	4G15
	VRJE	E	31/36	4.322	C97S, C97L	4G15
	VRLA	E	31/36	4.322	C62A	4G15
	F5M22-1-XPLL	B	29/36	4.592	N11W, N31W	4G93
	XPZL	B	29/36	4.592	N11W, N31W	4G93
	2-RRKA	B	31/36	4.021	C66A	4G92
	RRKE	B	31/36	4.021	CB4W	4G92
VPKF	B	29/36	4.021	E52A	4G93	
VPKF	B	29/36	4.021	E55A	4G63	
VPZF	B	29/36	4.021	E52A	4G93	
VRXG	B	31/36	4.021	C98S, C98L	4G92	
XRXE	B	31/36	4.592	CA5A	4G93	
F5M31-2-ZPVF	K	29/36	4.913	E54A	6A12 DOHC	
F5M33-2-SNOJ	J	28/36	4.153	F16A	6G72, 6G72 DOHC	
AUS	F5M21-1-RRBE	B	31/36	4.021	CA2A, CB2A	4G15
	VRLA	E	31/36	4.322	C62A	4G15
	F5M22-2-RRKA	B	31/36	4.021	C66A	4G92
	RRKE	B	31/36	4.021	CA5A, CB5A, CB5W	4G93
	VQKF	B	30/36	4.322	E55A	4G63
	F5M31-2-VNXL	K	28/36	4.322	N34W	4G64
	ZPVF	K	29/36	4.913	E54A	6A12 DOHC
	F5M33-2-SNXJ	J	28/36	4.153	F07W	6G72
	W5M33-2-NRBE	Q	31/36	4.933	CD5A	4G93

NOTE
DOHC: Double overhead camshaft

TRANSMISSION MODEL TABLE – MODEL 1994

Transmission model	Gear ratio	Speedometer gear ratio	Final gear ratio	Vehicle model	Engine model
EC F5M21-1-VRAE	E	31/36	4.233	CA1A, CB1A	4G13
	VRJE	E	31/36	4.233	CA1A, CB1A
F5M22-1-FDTE	B	31/36	3.752	CB8A	4D68
FRME	B	31/36	3.752	CB8A, CB8W	4D68
FRMG	B	31/36	3.752	CB8A, CB8W	4D68
XPXL	B	29/36	4.592	N33W	4G63
XPZL	B	29/36	4.592	N11W	4G93
XPZL	B	29/36	4.592	N34W	4G64
2-FRZE	B	31/36	3.752	CA4A	4G92
RRGE	B	31/36	4.021	CB4W	4G92
RRZE	B	31/36	4.021	CA4A, CB4A	4G92
VPZF	B	29/36	4.233	E52A	4G93
VQKF	B	30/36	4.233	E55A	4G63
VRXE	B	31/36	4.233	CA5A, CB5A	4G93
F5M31-1-VPMF	K	29/36	4.322	E57A	4D68
ZPML	K	29/36	4.913	N18W, N38W	4D68
2-ZPEF	K	29/36	4.913	E54A, E64A	6A12 DOHC
ZPGF	K	29/36	4.913	E54A	6A12 DOHC
ZPKF	K	29/36	4.913	E54A, E64A	6A12
ZPXF	K	29/36	4.913	E54A	6A12 DOHC
F5M33-2-SNEJ	J	28/36	4.153	F16A	6G72 DOHC
SNXJ	J	28/36	4.153	F16A	6G72, 6G72 DOHC
W5M31-2-VPCE	M	29/36	5.208	CD4W	4G92
VPXL	M	29/36	5.208	N21W	4G93
VPXL	O	29/36	5.208	N43W	4G63
VQBF	O	30/36	5.208	E75A	4G63
VRCE	M	31/36	5.208	CC4A	4G92
W5M33-2-WPXF	Q	29/36	5.443	E88A	6G73 DOHC

NOTE
DOHC: Double overhead camshaft

Transmission model	Gear ratio	Speedometer gear ratio	Final gear ratio	Vehicle model	Engine model
EXP F5M21-1-FDTE	B	31/36	3.752	CB8A	4D68
FDTG	B	31/36	3.752	CB8A	4D68
FRME	B	31/36	3.752	CB8A	4D68
FRMG	B	31/36	3.752	CB8A	4D68
RRAE	B	31/36	4.021	CA2A, CB2A	4G15
RRBE	B	31/36	4.021	CB1A, CB2A	4G15
RRJC	B	31/36	4.021	C12A	4G15
RRJE	B	31/36	4.021	CB3A	4G91
RRXE	B	31/36	4.021	CB4A	4G92
VRAC	E	31/36	4.322	C12A	4G15
VRAE	E	31/36	4.322	CA1A, CB1A, CB1W, CB2W	4G13
VRBE	E	31/36	4.322	CA1A, CB1A, CB1W, CB2W	4G13
VRJE	E	31/36	4.322	CB1A	4G13
F5M22-1-FDTG	B	31/36	3.752	CB8A	4D68
XPLL	B	29/36	4.592	N11W, N31W	4G93
XPZL	B	29/36	4.592	N11W, N31W	4G93
2-RRKE	B	31/36	4.021	CB4W	4G92
RRXE	B	31/36	4.021	CA4A, CB4A	4G92
VPKF	B	29/36	4.322	E52A	4G93
VPKF	B	29/36	4.322	E55A	4G63
VPZF	B	29/36	4.322	E52A	4G93
VRXE	B	31/36	4.322	CA5A	4G93
VRZE	B	31/36	4.322	CB5A	4G93
F5M31-2-ZPKF	K	29/36	4.913	E54A	6A12 DOHC
F5M33-2-SNQJ	J	28/36	4.153	F16A	6G72, 6G72 DOHC
AUS F5M22-2-VQKF	B	30/36	4.322	E55A	4G63
F5M31-2-VNXL	K	28/36	4.322	N34W	4G64
ZPKF	K	29/36	4.913	E54A	6A12 DOHC

NOTE
DOHC: Double overhead camshaft

TRANSMISSION MODEL TABLE – MODEL 1995

Transmission model	Gear ratio	Speedometer gear ratio	Final gear ratio	Vehicle model	Engine model	
EC	F5M21-1-VRAE	E	31/36	4.322	CA1A, CB1A	4G13
	VRJE	E	31/36	4.322	CA1A, CB1A	4G13
F5M22-1	FDTE	B	31/36	3.752	CB8A	4D68
	FRME	B	31/36	3.752	CB8A, CB8W	4D68
	FRMG	B	31/36	3.752	CB8A, CB8W	4D68
	2-FRZE	B	31/36	3.752	CB4A	4G92
	RRGE	B	31/36	4.021	CB4W	4G92
	RRZE	B	31/36	4.021	CB4A	4G92
	VRXE	B	31/36	4.322	CB5A	4G93
	VVZF	B	29/36	4.322	E52A	4G93
	VWKF	B	30/36	4.322	E55A	4G63
	F5M31-1	VVMF	K	29/36	4.322	E57A
ZPML		K	29/36	4.913	N18W, N38W	4D68
2-VPXL		K	29/36	4.322	N34W	4G64
ZVEF		K	29/36	4.913	E54A	6A12
ZVGF		K	29/36	4.913	E54A	6A12
ZVKF		K	29/36	4.913	E54A	6A12
ZVXF		K	29/36	4.913	E54A	6A12
F5M33-2		SNEJ	J	28/36	4.153	F16A
	SNXJ	J	28/36	4.153	F16A	6G72
W5M31-2	TPCE	M	29/36	5.124	CD4W	4G92
	TPXL	O	29/36	5.124	N21W, N43W	4G63
	VRCE	M	31/36	5.208	CC4A	4G92
	VWBF	O	30/36	5.208	E75A	4G63
W5M33-2	WVXF	Q	29/36	5.443	E88A	6G73

NOTE
DOHC: Double overhead camshaft

Transmission model	Gear ratio	Speedometer gear ratio	Final gear ratio	Vehicle model	Engine model	
EXP F5M21-1-RRAE	B	31/36	4.021	CA2A, CB2A	4G15	
	RRBE	B	31/36	CB2A	4G15	
	VRAE	E	31/36	CA1A, CB1A, CB1W, CB2W	4G13	
	VRBE	E	31/36	CA1A, CB1A, CB1W, CB2W	4G13	
	VRJE	E	31/36	CB2A	4G15	
F5M22-1-FDTE	B	31/36	3.752	CB8A	4D68	
	FDTG	B	31/36	CB8A	4D68	
	FRME	B	31/36	CB8A	4D68	
	FRMG	B	31/36	CB8A	4D68	
	XPLL	B	29/36	N31W	4G93	
	XPXL	B	29/36	N33W	4G63	
	2-RRKE	B	31/36	4.021	CA5A, CB4W	4G93
	RRXE	B	31/36	4.021	CA4A, CB4W	4G92
	VRXE	B	31/36	4.322	CA5A	4G93
	VRZE	B	31/36	4.322	CB5A	4G93
	VVKF	B	29/36	4.322	E52A, E55A	4G93
	VWZF	B	29/36	4.322	E52A	4G93
	F5M31-2-ZPKF	K	29/36	4.913	E54A	6A12 DOHC
ZVKF		K	29/36	E54A	6A12 DOHC	
F5M33-2-SNQJ	J	28/36	4.153	F16A	6G72	
AUS F5M21-1-RRBE	B	31/36	4.021	CA2A, CB2A	4G15	
	F5M22-2-RRKE	B	31/36	4.021	CA5A, CB5A, CB5W	4G93
		VVKF	B	30/36	E55A	4G63
	F5M31-2-VPXL	K	29/36	4.322	N34W	4G64
		ZVKF	K	29/36	E54A	6A12 DOHC
W5M33-2-NRBE	Q	31/36	4.933	CD5A	4G93	

NOTE
DOHC: Double overhead camshaft

TRANSMISSION MODEL TABLE – MODEL 1996

Transmission model	Gear ratio	Speedometer gear ratio	Final gear ratio	Vehicle model	Engine model		
EC	F5M22-1-XPXL	B	29/36	4.322	N33W	4G63	
	XPZL	B	29/36	4.322	N11W	4G93	
	2-VVZF	B	29/36	4.322	E52A	4G93	
	VVKF	B	30/36	4.322	E55A	4G63	
F5M31-1-ZPML	F5M31-1-ZPML	K	29/36	4.913	N18W, N38W	4D68 Turbo	
	2-VPXL	K	29/36	4.322	N34W	4G64	
	VVMF	K	29/36	4.322	E57A	4D68 Turbo	
	ZVEF	K	29/36	4.913	E54A	6A12 DOHC	
	ZVGF	K	29/36	4.913	E54A	6A12 DOHC	
	ZVKF	K	29/36	4.913	E54A	6A12 DOHC	
	ZVXF	K	29/36	4.913	E54A	6A12 DOHC	
	ZVZT	K	29/36	4.913	D32A	4G63 DOHC Intercooler Turbo	
	W5M31-2-TPXL	W5M31-2-TPXL	O	29/36	5.124	N21W, N43W	4G63
		VWBF	O	30/36	5.208	E75A	4G63
W5M33-2-WVXF	Q	29/36	5.443	E88A	6G73 DOHC		
EXP	F5M22-1-VPXL	B	29/36	4.322	E55A	4G63	
	XPLL	B	29/36	4.322	N31W	4G93	
	XPXL	B	29/36	4.322	N33W	4G63	
	XPZL	B	29/36	4.322	N11W	4G93	
	2-VVKF	B	29/36	4.322	E52A	4G93	
	VVKF	B	29/36	4.322	E55A	4G63	
	VVZF	B	29/36	4.322	E52A	4G93	
	F5M31-2-ZVKF	K	29/36	4.913	E54A	6A12, 6A12 DOHC	
F5M33-2-SNOJ	J	28/36	4.153	F16A	6G72, 6G72 DOHC		
AUS	F5M21-1-RRBE	B	31/36	4.021	CA2A, CB2A	4G15	
	F5M22-2-RRKF	B	31/36	4.021	CA5A, CB5A, CB5W	4G93	
	VVKF	B	30/36	4.322	E54A	4G63	
	F5M31-2-XPXL	K	29/36	4.511	N34W	4G64	
	ZVKF	K	29/36	4.913	E55A	6A12 DOHC	

NOTE
DOHC: Double overhead camshaft

Intentionally blank

**GEAR RATIO TABLE
FOR FRONT WHEEL DRIVE**

	A	B	C	D	E
1st	3.363	3.363	3.454	3.363	3.083
2nd	1.947	1.947	1.947	1.947	1.947
3rd	1.285	1.285	1.285	1.285	1.285
4th	0.939	0.939	0.937	0.939	0.939
5th	–	0.756	0.756	0.777	0.756
Reverse	3.083	3.083	3.083	3.083	3.083

	F	G	H	I	J	K
1st	3.166	3.166	3.250	3.166	3.090	2.846
2nd	1.833	1.833	1.833	1.833	1.833	1.833
3rd	1.240	1.240	1.240	1.240	1.217	1.217
4th	0.860	0.896	0.896	0.896	0.888	0.888
5th	0.731	0.690	0.690	0.731	0.741	0.731
Reverse	3.166	3.166	3.166	3.166	3.166	3.166

FOR FOUR WHEEL DRIVE

	L	M	N	O	P	Q
1st	3.083	3.083	2.846	2.846	2.916	2.846
2nd	1.684	1.684	1.684	1.684	1.684	1.684
3rd	1.115	1.115	1.115	1.115	1.115	1.115
4th	0.806	0.806	0.833	0.833	0.833	0.833
5th	0.651	0.651	0.651	0.690	0.666	0.666
Reverse	3.166	3.166	3.166	3.166	3.166	3.166
Transfer	0.875	1.090	1.090	1.090	1.090	1.090

SERVICE SPECIFICATIONS**FOR FRONT WHEEL DRIVE**

mm (in.)

Standard

Transmission

Input shaft bearing end play	0.01 – 0.12 (0.0004 – 0.0047)
Input shaft preload	0 – 0.05 (0 – 0.002): F5M33
Input shaft rear bearing end play	0 – 0.09 (0 – 0.0035): F5M21, F5M22, F5M31, F5M33
Intermediate gear bearing end play	0.01 – 0.14 (0.0004 – 0.0055): F4M21, F5M21, F5M22, F5M33
	0.01 – 0.11 (0.0004 – 0.0044): F5M31
Intermediate gear end play	0.05 – 0.17 (0.002 – 0.007): F4M21, F5M21
Intermediate gear preload	0.05 – 0.10 (0.002 – 0.004): F5M22, F5M31, F5M33
Output shaft end play (Up to JUN. 1987)	0.05 – 0.17 (0.002 – 0.007): F4M21, F5M21
Output shaft preload (From JUL. 1987)	0.05 – 0.10 (0.002 – 0.004): F4M21, F5M21, F5M33
Output shaft preload	0.05 – 0.10 (0.002 – 0.004): F5M22, F5M31, F5M33

Differential

Differential case end play	0.05 – 0.17 (0.002 – 0.007): F4M21, F5M21
Differential case preload	0.05 – 0.10 (0.002 – 0.004): F5M22, F5M31, F5M33
Differential pinion backlash	0.025 – 0.150 (0.001 – 0.006)

FOR FOUR WHEEL DRIVE

mm (in.)

Standard

Transmission

Input shaft end play	0 – 0.05 (0 – 0.0020): W5M33
Input shaft front bearing end play	0.01 – 0.12 (0.0004 – 0.0047): W5M31
Input shaft rear bearing end play	0 – 0.09 (0 – 0.0035)
Intermediate gear bearing end play	0.01 – 0.11 (0.0004 – 0.0043): W5M31
	0.01 – 0.14 (0.0004 – 0.0055): W5M33
Intermediate gear preload	0.08 – 0.13 (0.0031 – 0.0051)
Front output shaft preload	0.08 – 0.13 (0.0031 – 0.0051)

Center differential

Clutch gear end play	0.10 – 0.26 (0.0039 – 0.0102)
Viscous coupling end play	0.10 – 0.26 (0.0039 – 0.0102)
Differential case preload	0.08 – 0.13 (0.0031 – 0.0051)
Differential side gear end play	0.05 – 0.25 (0.0020 – 0.0100)

Front differential

Differential case end play	0.05 – 0.17 (0.0020 – 0.0067)
Differential pinion backlash	0.025 – 0.150 (0.0010 – 0.0059)

Transfer

Bevel gear set backlash	0.08 – 0.13 (0.0031 – 0.0051)
Drive bevel gear shaft rotating torque	1.7 – 2.5 Nm (1.23 – 1.81 ft.lbs.)
Driven bevel gear rotating torque	1.0 – 1.7 Nm (0.72 – 1.23 ft.lbs.)

SEALANTS AND ADHESIVES

	Specified sealants and adhesives	Quantity
Transmission case – rear cover mating surfaces	Mitsubishi genuine sealant Part No. MD997740 or equivalent	As required
Transmission case – clutch housing mating surfaces	Mitsubishi genuine sealant Part No. MD997740 or equivalent	As required
Adapter (Four wheel drive model only) – transmission case mating surfaces	Mitsubishi genuine sealant Part No. MD997740 or equivalent	As required
Adapter (Four wheel drive model only) – rear cover mating surfaces	Mitsubishi genuine sealant Part No. MD997740 or equivalent	As required
Output gear bolt (Four wheel drive model only)	3M STUD Locking No. 4170 or equivalent	As required
Differential drive gear bolts	3M STUD Locking No. 4170 or equivalent	As required
Bearing retainer bolt (Countersink head bolt only)	3M STUD Locking No. 4170 or equivalent	As required
Air breather	3M SUPER WEATHERSTRIP No. 8001 or equivalent	As required
Transfer extension housing – adapter mating surfaces	THREE BOND TB1216 or equivalent	As required
Transfer cover gasket	3M ATD Part No. 8660 or equivalent	As required

ADJUSTMENT SNAP RINGS AND SPACERS

Part name	Thickness mm (in.)	Identification symbol	Part No.
Snap ring (For adjustment of input shaft front bearing end play)	2.24 (0.0882)	None	MD706537
	2.31 (0.0909)	Blue	MD706538
	2.38 (0.0937)	Brown	MD706539
Snap ring: F5M21, F5M22 (For adjustment of input shaft rear bearing end play)	1.80 (0.0709)	Blue	MD730785
	1.87 (0.0736)	White	MD730786
	1.94 (0.0764)	None	MD730787
	2.01 (0.0791)	Green	MD730788
	2.08 (0.0819)	Yellow	MD730834
	2.15 (0.0846)	Brown	MD730835
Snap ring: F5M31, F5M33, W5M31, W5M33 (For adjustment of input shaft rear bearing end play)	1.40 (0.0551)	Blue	MD723276
	1.45 (0.0571)	Purple	MD730889
	1.50 (0.0591)	Red	MD723277
	1.55 (0.0610)	White	MD730890
	1.60 (0.0630)	Yellow	MD723278
	1.65 (0.0650)	Brown	MD730891
	1.70 (0.0670)	Green	MD723279
	1.75 (0.0689)	Orange	MD730892
Spacer: F5M33, W5M33 (For adjustment of input shaft preload)	0.80 (0.0315)	80	MD727661
	0.83 (0.0327)	83	MD720937
	0.86 (0.0338)	86	MD720938
	0.89 (0.0350)	89	MD720939
	0.92 (0.0362)	92	MD720940
	0.95 (0.0374)	95	MD720941
	0.98 (0.0386)	98	MD720942
	1.01 (0.0398)	01	MD720943
	1.04 (0.0409)	04	MD720944
	1.07 (0.0421)	07	MD720945
	1.10 (0.0433)	J	MD710454
	1.13 (0.0445)	D	MD700270
	1.16 (0.0457)	K	MD710455
	1.19 (0.0468)	L	MD710456
	1.22 (0.0480)	G	MD700271
	1.25 (0.0492)	M	MD710457
1.28 (0.0504)	N	MD710458	
1.31 (0.0516)	E	MD706574	
1.34 (0.0527)	O	MD710459	
1.37 (0.0539)	P	MD710460	
1.40 (0.0551)	–	MD706573	
1.43 (0.0563)	Q	MD710461	
1.46 (0.0575)	R	MD710462	

Part name	Thickness mm (in.)	Identification symbol	Part No.
Snap ring: F4M21, F5M21, F5M22, F5M33 (For adjustment of intermediate gear front bearing end play)	1.40 (0.0551)	None	MD703779
	1.50 (0.0591)	Brown	MD703780
	1.60 (0.0630)	Blue	MD703781
Snap ring: F5M31 (For adjustment of intermediate gear front bearing end play)	1.40 (0.0551)	Blue	MD723276
	1.50 (0.0591)	Red	MD723277
	1.60 (0.0630)	Yellow	MD723278
	1.70 (0.0670)	Green	MD723279
Spacer: F4M21, F5M21 (For adjustment of intermediate gear end play)	0.47 (0.0185)	47	MD736750
	0.56 (0.0220)	56	MD720969
	0.65 (0.0256)	65	MD720970
	0.74 (0.0291)	74	MD720971
	0.83 (0.0327)	83	MD720972
	0.92 (0.0362)	92	MD720973
	1.01 (0.0394)	01	MD720974
	1.10 (0.0433)	10	MD718511
	1.19 (0.0469)	19	MD736751
Spacer: F5M22 (For adjustment of intermediate gear preload)	0.62 (0.0244)	62	MD736752
	0.65 (0.0256)	65	MD736753
	0.68 (0.0268)	68	MD735663
	0.71 (0.0280)	71	MD735664
	0.74 (0.0291)	74	MD735665
	0.77 (0.0303)	77	MD735666
	0.80 (0.0315)	80	MD723307
	0.83 (0.0327)	83	MD723308
	0.86 (0.0338)	86	MD723309
	0.89 (0.0350)	89	MD723310
	0.92 (0.0362)	92	MD723311
	0.95 (0.0374)	95	MD723312
	0.98 (0.0394)	98	MD723313
	1.01 (0.0398)	01	MD723314
	1.04 (0.0409)	04	MD723315
	1.07 (0.0421)	07	MD723316
	1.10 (0.0433)	10	MD723317
1.13 (0.0445)	13	MD723318	
1.16 (0.0457)	16	MD723319	
1.19 (0.0468)	19	MD723320	
1.22 (0.0480)	22	MD723321	
1.25 (0.0492)	25	MD723322	
1.28 (0.0504)	28	MD723323	
1.31 (0.0516)	31	MD723324	
1.34 (0.0527)	34	MD723325	
1.37 (0.0539)	37	MD723326	

Part name	Thickness mm (in.)	Identification symbol	Part No.
Spacer: F5M31, F5M33 (For adjustment of intermediate gear preload)	0.68 (0.0268)	68	MD735659
	0.71 (0.0280)	71	MD735660
	0.74 (0.0291)	74	MD735661
	0.77 (0.0303)	77	MD735662
	0.80 (0.0315)	80	MD724142
	0.83 (0.0327)	83	MD724143
	0.86 (0.0338)	86	MD724144
	0.89 (0.0350)	89	MD724145
	0.92 (0.0362)	92	MD724146
	0.95 (0.0374)	95	MD724147
	0.98 (0.0386)	98	MD724148
	1.01 (0.0398)	01	MD724149
	1.04 (0.0409)	04	MD724150
	1.07 (0.0421)	07	MD724151
	1.10 (0.0433)	10	MD724152
	1.13 (0.0445)	13	MD724153
	1.16 (0.0457)	16	MD724154
	1.19 (0.0468)	19	MD724155
	1.22 (0.0480)	22	MD724156
	1.25 (0.0492)	25	MD724157
1.28 (0.0504)	28	MD724158	
1.31 (0.0516)	31	MD724159	
1.34 (0.0527)	34	MD724160	
1.37 (0.0539)	37	MD724161	
Spacer: W5M31 (For adjustment of intermediate gear preload)	1.19 (0.0468)	19	MD720962
	1.22 (0.0480)	22	MD720961
	1.25 (0.0492)	25	MD712346
	1.28 (0.0504)	28	MD712347
	1.31 (0.0516)	31	MD712348
	1.34 (0.0527)	34	MD712349
	1.37 (0.0539)	37	MD712329
	1.40 (0.0551)	40	MD712330
	1.43 (0.0563)	43	MD712331
	1.46 (0.0575)	46	MD712332
	1.49 (0.0587)	49	MD712333
	1.52 (0.0598)	52	MD712334
	1.55 (0.0610)	55	MD712335
	1.58 (0.0622)	58	MD712336
	1.61 (0.0634)	61	MD712337
	1.64 (0.0646)	64	MD712338
	1.67 (0.0657)	67	MD712339
	1.70 (0.0669)	70	MD712340
1.73 (0.0681)	73	MD712341	
1.76 (0.0692)	76	MD712342	
1.79 (0.0705)	79	MD712343	
1.82 (0.0716)	82	MD712344	
1.85 (0.0728)	85	MD712345	

Part name	Thickness mm (in.)	Identification symbol	Part No.
Spacer W5M33 (For adjustment of intermediate gear preload)	0.80 (0.0315)	80	MD720948
	0.83 (0.0327)	83	MD720949
	0.86 (0.0338)	86	MD720950
	0.89 (0.0350)	89	MD720951
	0.92 (0.0362)	92	MD720952
	0.95 (0.0374)	95	MD720953
	0.98 (0.0386)	98	MD720954
	1.01 (0.0398)	01	MD720955
	1.04 (0.0409)	04	MD720956
	1.07 (0.0421)	07	MD720957
	1.10 (0.0433)	10	MD720958
	1.13 (0.0445)	13	MD720959
	1.16 (0.0457)	16	MD720960
	1.19 (0.0468)	19	MD720961
	1.22 (0.0480)	22	MD720962
	1.25 (0.0492)	25	MD712346
	1.28 (0.0504)	28	MD712347
	1.31 (0.0516)	31	MD712348
	Spacer: F4M21, F5M21: Up to JUN. 1987 (For adjustment of output shaft end play)	1.34 (0.0527)	34
1.37 (0.0539)		37	MD712329
1.40 (0.0551)		40	MD712330
1.43 (0.0563)		43	MD712331
0.65 (0.0256)		65	MD720946
0.74 (0.0291)		74	MD720947
Spacer: F4M21, F5M21: From JUL. 1987, F5M22 (For adjustment of output shaft preload)	0.83 (0.0327)	83	MD720949
	0.92 (0.0392)	92	MD720952
	1.01 (0.0398)	01	MD720955
	1.10 (0.0433)	10	MD720958
	0.74 (0.0291)	74	MD720947
	0.77 (0.0303)	77	MD736756
	0.80 (0.0315)	80	MD720948
	0.83 (0.0327)	83	MD720949
	0.86 (0.0338)	86	MD720950
	0.89 (0.0350)	89	MD720951
	0.92 (0.0362)	92	MD720952
0.95 (0.0374)	95	MD720953	
0.98 (0.0386)	98	MD720954	
1.01 (0.0398)	01	MD720955	
1.04 (0.0409)	04	MD720956	
1.07 (0.0421)	07	MD720957	

Part name	Thickness mm (in.)	Identification symbol	Part No.
Spacer: F4M21, F5M21: From JUL. 1987, F5M22 (For adjustment of output shaft preload)	1.10 (0.0433)	10	MD720958
	1.13 (0.0445)	13	MD720959
	1.16 (0.0457)	16	MD720960
	1.19 (0.0468)	19	MD720961
	1.22 (0.0480)	22	MD720362
	1.25 (0.0492)	25	MD712346
	1.28 (0.0504)	28	MD712347
	1.31 (0.0516)	31	MD712348
	1.34 (0.0527)	34	MD712349
Spacer: F5M31, F5M33 (For adjustment of output shaft preload)	0.83 (0.0327)	83	MD720937
	0.86 (0.0338)	86	MD720938
	0.89 (0.0350)	89	MD720939
	0.92 (0.0362)	92	MD720940
	0.95 (0.0374)	95	MD720941
	0.98 (0.0386)	98	MD720942
	1.01 (0.0398)	01	MD720943
	1.04 (0.0409)	04	MD720944
	1.07 (0.0421)	07	MD720945
	1.10 (0.0433)	J	MD710454
	1.13 (0.0445)	D	MD700270
	1.16 (0.0457)	K	MD710455
	1.19 (0.0468)	L	MD710456
	1.22 (0.0480)	G	MD700271
	1.25 (0.0492)	M	MD710457
	1.28 (0.0504)	N	MD710458
1.31 (0.0516)	E	MD706574	
1.34 (0.0527)	O	MD710459	
Spacer: F4M21, F5M21, W5M31, W5M33 (For adjustment of front differential case end play)	0.56 (0.0220)	56	MD727658
	0.65 (0.0256)	65	MD727659
	0.74 (0.0291)	74	MD727660
	0.83 (0.0327)	83	MD720937
	0.92 (0.0362)	92	MD720940
	1.01 (0.0398)	01	MD720943
	1.10 (0.0433)	J	MD710454
	1.19 (0.0468)	L	MD710456
	1.28 (0.0504)	N	MD710458
1.37 (0.0539)	P	MD710460	
Spacer: F5M22, F5M31, F5M33 (For adjustment of front differential case preload)	0.80 (0.0315)	80	MD727661
	0.83 (0.0327)	83	MD720937
	0.86 (0.0338)	86	MD720938
	0.89 (0.0350)	89	MD720939
	0.92 (0.0362)	92	MD720940
	0.95 (0.0374)	95	MD720941
0.98 (0.0386)	98	MD720942	

Part name	Thickness mm (in.)	Identification symbol	Part No.
Spacer: F5M22, F5M31, F5M33 (For adjustment of front differential case preload)	1.01 (0.0398)	01	MD720943
	1.04 (0.0409)	04	MD720944
	1.07 (0.0421)	07	MD720945
	1.10 (0.0433)	J	MD710454
	1.13 (0.0445)	D	MD700270
	1.16 (0.0457)	K	MD710455
	1.19 (0.0468)	L	MD710456
	1.22 (0.0480)	G	MD700271
	1.25 (0.0492)	M	MD710457
Spacer (For adjustment of front differential pinion backlash)	0.75 – 0.82 (0.0295 – 0.0323)	–	MA180862
	0.83 – 0.92 (0.0327 – 0.0362)	–	MA180861
	0.93 – 1.00 (0.0366 – 0.0394)	–	MA180860
	1.01 – 1.08 (0.0398 – 0.0425)	–	MA180875
	1.09 – 1.16 (0.0429 – 0.0457)	–	MA180876
Spacer: W5M31, W5M33 (For adjustment of front output shaft preload)	1.28 (0.0504)	B28	MD726167
	1.31 (0.0516)	B31	MD726168
	1.34 (0.0527)	B34	MD726169
	1.37 (0.0539)	B37	MD724326
	1.40 (0.0551)	B40	MD724327
	1.43 (0.0563)	B43	MD724328
	1.46 (0.0575)	B46	MD724329
	1.49 (0.0587)	B49	MD724330
	1.52 (0.0598)	B52	MD724331
	1.55 (0.0610)	B55	MD724332
	1.58 (0.0622)	B58	MD724333
	1.61 (0.0634)	B61	MD724334
	1.64 (0.0646)	B64	MD724335
	1.67 (0.0657)	B67	MD724336
	1.70 (0.0669)	B70	MD724337
	1.73 (0.0681)	B73	MD724338
1.76 (0.0692)	B76	MD724339	
1.79 (0.0705)	B79	MD724340	
1.82 (0.0716)	B82	MD724341	
1.85 (0.0728)	B85	MD724342	
1.88 (0.0740)	B88	MD724343	
1.91 (0.0751)	B91	MD724344	

Part name	Thickness mm (in.)	Identification symbol	Part No.
Snap ring: W5M31, W5M33 [For adjustment of clutch gear end play (with diff.lock) and viscous coupling end play (with VCU)]	1.3 (0.0512)	Orange	MD727650
	1.4 (0.0551)	Red	MD720686
	1.5 (0.0591)	Blue	MD720687
	1.6 (0.0630)	None	MD720688
	1.7 (0.0669)	White	MD720689
	1.8 (0.0709)	Yellow	MD720690
	1.9 (0.0748)	Green	MD727651
Spacer: W5M31 (For adjustment of center differential pinion backlash, front side)	0.59 – 0.66 (0.0232 – 0.0260)	73	MD724973
	0.67 – 0.74 (0.0264 – 0.0291)	47	MD724947
	0.75 – 0.82 (0.0295 – 0.0323)	46	MD724946
	0.83 – 0.92 (0.0327 – 0.0362)	45	MD724945
	0.93 – 1.00 (0.0366 – 0.0394)	81	MD720681
	1.01 – 1.08 (0.0398 – 0.0425)	44	MD724944
	1.09 – 1.16 (0.0429 – 0.0457)	43	MD724943
	1.17 – 1.24 (0.0421 – 0.0488)	42	MD724942
	1.25 – 1.32 (0.0492 – 0.0520)	72	MD724972
Spacer: W5M33 (For adjustment of center differential pinion backlash, front side)	2.09 – 2.16 (0.0823 – 0.0850)	0	MD741413
	2.17 – 2.24 (0.0854 – 0.0882)	9	MD741412
	2.25 – 2.32 (0.0886 – 0.0913)	8	MD741411
	2.33 – 2.42 (0.0917 – 0.0953)	7	MD741410
	2.43 – 2.50 (0.0857 – 0.0984)	6	MD741409
	2.51 – 2.58 (0.0988 – 0.1016)	5	MD741408
	2.59 – 2.66 (0.1020 – 0.1047)	4	MD741407
	2.67 – 2.74 (0.1050 – 0.1079)	3	MD741406
	2.75 – 2.82 (0.1083 – 0.1110)	2	MD741405

Part name	Thickness mm (in.)	Identification symbol	Part No.
Spacer: W5M31 (For adjustment of center differential case preload)	1.13 (0.0445)	13	MD736928
	1.16 (0.0457)	16	MD736929
	1.19 (0.0468)	19	MD736751
	1.22 (0.0480)	22	MD736931
	1.25 (0.0492)	25	MD726166
	1.28 (0.0504)	28	MD718517
	1.31 (0.0516)	31	MD718518
	1.34 (0.0527)	34	MD718519
	1.37 (0.0539)	37	MD718520
	1.40 (0.0551)	40	MD718521
	1.43 (0.0563)	43	MD718522
	1.46 (0.0575)	46	MD718523
	1.49 (0.0587)	49	MD718524
	1.52 (0.0598)	52	MD718525
	1.55 (0.0610)	55	MD718526
	1.58 (0.0622)	58	MD718527
	1.61 (0.0634)	61	MD718528
	1.64 (0.0646)	64	MD718529
	1.67 (0.0657)	67	MD718530
1.70 (0.0669)	70	MD718531	
1.73 (0.0681)	73	MD721959	
1.76 (0.0692)	76	MD721960	
1.79 (0.0705)	79	MD721961	
Spacer: W5M31, W5M33 (For adjustment of center differential pinion backlash, rear side)	0.59 – 0.66 (0.0232 – 0.0260)	74	MD724974
	0.67 – 0.74 (0.0264 – 0.0291)	50	MD724950
	0.75 – 0.82 (0.0295 – 0.0323)	80	MD720680
	0.83 – 0.92 (0.0327 – 0.0362)	79	MD720679
	0.93 – 1.00 (0.0366 – 0.0394)	78	MD720678
	1.01 – 1.08 (0.0398 – 0.0425)	76	MD720676
	1.09 – 1.16 (0.0429 – 0.0457)	77	MD720677
	1.17 – 1.24 (0.0421 – 0.0488)	49	MD724949

Part name	Thickness mm (in.)	Identification symbol	Part No.
Spacer: W5M31, W5M33 (For adjustment of drive bevel gear mount)	1.34 (0.0528)	34	MD723600
	1.37 (0.0539)	37	MD723601
	1.40 (0.0551)	40	MD723602
	1.43 (0.0563)	43	MD723603
	1.46 (0.0575)	46	MD723604
	1.49 (0.0587)	49	MD723605
	1.52 (0.0598)	52	MD723606
	1.55 (0.0610)	55	MD723607
	1.58 (0.0622)	58	MD723608
	1.61 (0.0634)	61	MD723609
Spacer: W5M31, W5M33 (For adjustment of drive bevel gear preload)	1.64 (0.0646)	64	MD726170
	1.67 (0.0657)	67	MD726171
	1.28 (0.0504)	B28	MD726167
	1.31 (0.0516)	B31	MD726168
	1.34 (0.0528)	B34	MD726169
	1.37 (0.0539)	B37	MD724326
	1.40 (0.0551)	B40	MD724327
	1.43 (0.0563)	B43	MD724328
	1.46 (0.0575)	B46	MD724329
	1.49 (0.0587)	B49	MD724330
Spacer: W5M31, W5M33 (For adjustment of driven bevel gear mount)	1.52 (0.0598)	B52	MD724331
	1.55 (0.0610)	B55	MD724332
	1.58 (0.0622)	B58	MD724333
	1.61 (0.0634)	B61	MD724334
	1.64 (0.0646)	B64	MD724335
	1.67 (0.0657)	B67	MD724336
	1.70 (0.0669)	B70	MD724337
	1.73 (0.0681)	B73	MD724338
	1.76 (0.0693)	B76	MD724339
	1.79 (0.0705)	B79	MD724340
Spacer: W5M31, W5M33 (For adjustment of driven bevel gear mount)	1.82 (0.0717)	B82	MD724341
	1.85 (0.0728)	B85	MD724342
	0.13 (0.0051)	13	MD720353
	0.16 (0.0063)	16	MD720354
	0.19 (0.0075)	19	MD720355
	0.22 (0.0087)	22	MD720356
	0.25 (0.0098)	25	MD720357
	0.28 (0.0110)	28	MD720358
	0.31 (0.0122)	31	MD720359
	0.34 (0.0134)	34	MD720360
0.37 (0.0146)	37	MD720361	
0.40 (0.0157)	40	MD720362	
0.43 (0.0169)	43	MD720363	
0.46 (0.0181)	46	MD720364	
0.49 (0.0193)	49	MD720365	
0.52 (0.0205)	52	MD720366	

Part name	Thickness mm (in.)	Identification symbol	Part No.
Spacer: W5M31, W5M33 (For adjustment of driven bevel gear preload)	1.19 (0.0469)	19	MD726172
	1.22 (0.0480)	22	MD722081
	1.25 (0.0492)	25	MD722082
	1.28 (0.0504)	28	MD722083
	1.31 (0.0516)	31	MD722084
	1.34 (0.0528)	34	MD722085
	1.37 (0.0539)	37	MD722086
	1.40 (0.0551)	40	MD722087
	1.43 (0.0563)	43	MD722088
	1.46 (0.0575)	46	MD722089
	1.49 (0.0587)	49	MD722090
	1.52 (0.0598)	52	MD722091
	1.55 (0.0610)	55	MD722092
	1.58 (0.0622)	58	MD722093
	1.61 (0.0634)	61	MD722094
	1.64 (0.0646)	64	MD722095
	1.67 (0.0657)	67	MD722096
	1.70 (0.0669)	70	MD722097
	1.73 (0.0681)	73	MD722098
	1.76 (0.0693)	76	MD722099
1.79 (0.0705)	79	MD722100	
1.82 (0.0717)	82	MD722101	
1.85 (0.0728)	85	MD722102	
1.88 (0.0740)	88	MD722103	
1.91 (0.0752)	91	MD722104	
1.94 (0.0764)	94	MD722105	



TORQUE SPECIFICATIONS

	Torque		
	Nm	kgm	ft.lbs.
Transmission			
Backup light switch	30 – 35	3.0 – 3.5	22 – 25
Bearing retainer bolt	15 – 22	1.5 – 2.2	11 – 15
Bell housing cover mounting bolt	8.0 – 10	0.8 – 1.0	5.8 – 7.2
Center differential lock actuator mounting bolt (Four wheel drive model only)	15 – 22	1.5 – 2.2	11 – 15
Center differential lock indicator lamp switch (Four wheel drive model only)	30 – 35	3.0 – 3.5	22 – 25
Center differential shift lever mounting bolt (Four wheel drive model only)	15 – 22	1.5 – 2.2	11 – 15
Differential drive gear bolt	130 – 140	13 – 14	94 – 101
Input shaft lock nut	140 – 160	14 – 16	102 – 115
Interlock plate bolt	20 – 27	2.0 – 2.7	15 – 19
Intermediate gear lock nut	140 – 160	14 – 16	102 – 115
Oil drain plug	30 – 35	3.0 – 3.5	22 – 25
Oil filler plug	30 – 35	3.0 – 3.5	22 – 25
Output gear mounting bolt	70 – 80	7.0 – 8.0	51 – 57
Poppet plug	30 – 42	3.0 – 4.2	22 – 30
Rear cover bolt (Four wheel drive model only)	35 – 42	3.5 – 4.2	26 – 30
Rear cover bolt (Front wheel drive model only)	15 – 22	1.5 – 2.2	11 – 15
Restrict ball	30 – 35	3.0 – 3.5	22 – 25
Reverse brake cone machine screw	6.5 – 7.5	0.65 – 0.75	4.7 – 5.4
Reverse idler gear shaft bolt	43 – 55	4.3 – 5.5	32 – 39
Reverse shift lever assembly attaching bolt	15 – 22	1.5 – 2.2	11 – 15
Select lever mounting bolt	15 – 22	1.5 – 2.2	11 – 15
Shift cable bracket mounting bolt	15 – 22	1.5 – 2.2	11 – 15
Speedometer sleeve bolt	3.0 – 5.0	0.3 – 0.5	2.5 – 3.5
Starter motor mounting bolt	22 – 32	2.2 – 3.2	16 – 23
Stopper bracket bolt	15 – 22	1.5 – 2.2	11 – 15
Transmission case tightening bolt	35 – 42	3.5 – 4.2	26 – 30
Transmission mount bracket mounting bolt	60 – 80	6.0 – 8.0	44 – 57
Transmission mounting bolt			
[10 mm diameter bolt]	43 – 55	4.3 – 5.5	32 – 39
[8 mm diameter bolt]	22 – 32	2.2 – 3.2	16 – 23
[6 mm diameter bolt]	10 – 12	1.0 – 1.2	7.3 – 8.6
Transmission switch (Front wheel drive model only)	30 – 35	3.0 – 3.5	22 – 25
Transfer			
Cover mounting bolt	8.0 – 10	0.8 – 1.0	5.8 – 7.2
Driven bevel gear lock nut	140 – 160	14 – 16	102 – 115
Extension housing	15 – 22	1.5 – 2.2	11 – 15
Oil drain plug	30 – 35	3.0 – 3.5	22 – 25
Oil filler plug	30 – 35	3.0 – 3.5	22 – 25
Transfer case adapter mounting bolt	35 – 42	3.5 – 4.2	26 – 30
Transfer cover mounting bolt	35 – 42	3.5 – 4.2	26 – 30
Transfer hanger bracket	15 – 22	1.5 – 2.2	11 – 15
Transfer mounting bolt	55 – 60	5.5 – 6.0	40 – 43

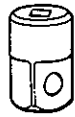
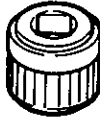
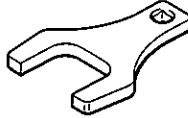
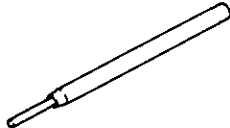
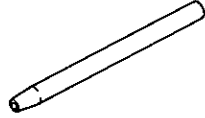
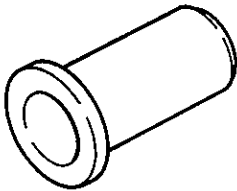
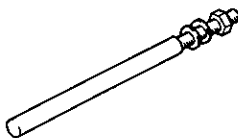
2. SPECIAL TOOLS

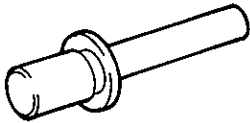
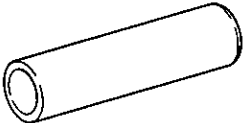
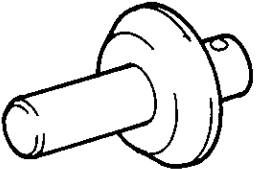
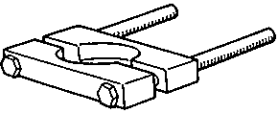
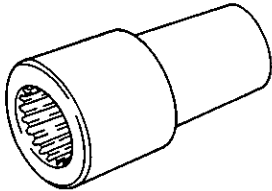
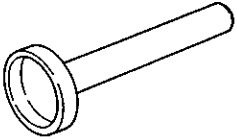
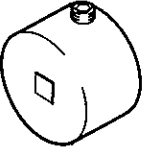
Tool	Number	Name	Use
	MB990326	Preload socket	Measurement of drive bevel gear shaft rotating torque (Four wheel drive model only)
	MB990990	Side gear holding Tool (A)	Measurement of drive bevel gear shaft rotating torque (Four wheel drive model only)
	MB991013	Special spanner	Installation and removal of driven bevel gear lock nut (Four wheel drive model only)
	MD998019	Lock pin extractor	Removal of spring pin and lock pin
	MD998245	Lock pin installer	Installation of spring pin and lock pin
	MD998304	Oil seal installer	Press-fitting of front output shaft bearing (Four wheel drive model only)
	MD998316	Dial gauge support	Measurement of driven bevel gear and drive bevel gear backlash (Four wheel drive model only)

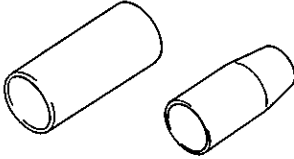
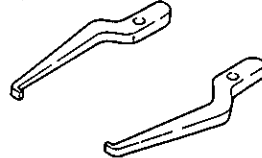
Tool	Number	Name	Use
	MD998321	Oil seal installer	Installation of input shaft front oil seal
	MD998323	Bearing installer	Installation of transfer case oil seal (Four wheel drive model only)
	MD998325	Differential oil seal installer	Installation of differential oil seal
	MD998801	Bearing remover	Press-fitting of bearing and gear to input shaft, intermediate gear and front output shaft
	MD998802	Input shaft holder	Removal and installation of input shaft and intermediate gear lock nut
	MD998803	Differential oil seal installer	Installation of differential oil seal (Four wheel drive model only)
	MD998806	Wrench adapter	Measurement of driven bevel gear rotating torque (Four wheel drive model only)

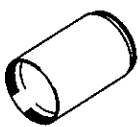
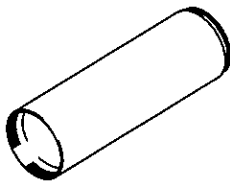
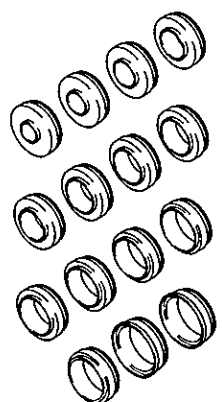
Tool	Number	Name	Use
	MD998808	Snap ring installer	Installation of snap ring to input shaft rear bearing
	MD999566	Claw	Removal to taper roller bearing outer race (Four wheel drive model only)
	MD998812	Installer cap	Installation of each bearing
	MD998813	Installer (100)	Installation of each bearing
	MD998814	Installer (200)	Installation of each bearing
	MD998815 MD998816 MD998817 MD998818 MD998819 MD998820 MD998821 MD998822 MD998823 MD998824 MD998825 MD998826 MD998827 MD998829 MD998830	Installer adapter	Installation of each bearing

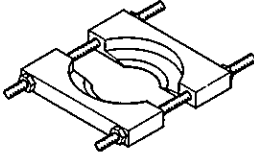
Tool	Number	Name	Use
	MD998917	Bearing remover	Removal of intermediate gear bearing (F4M21, F5M21)

3. TRANSMISSION

F4M21, F5M21

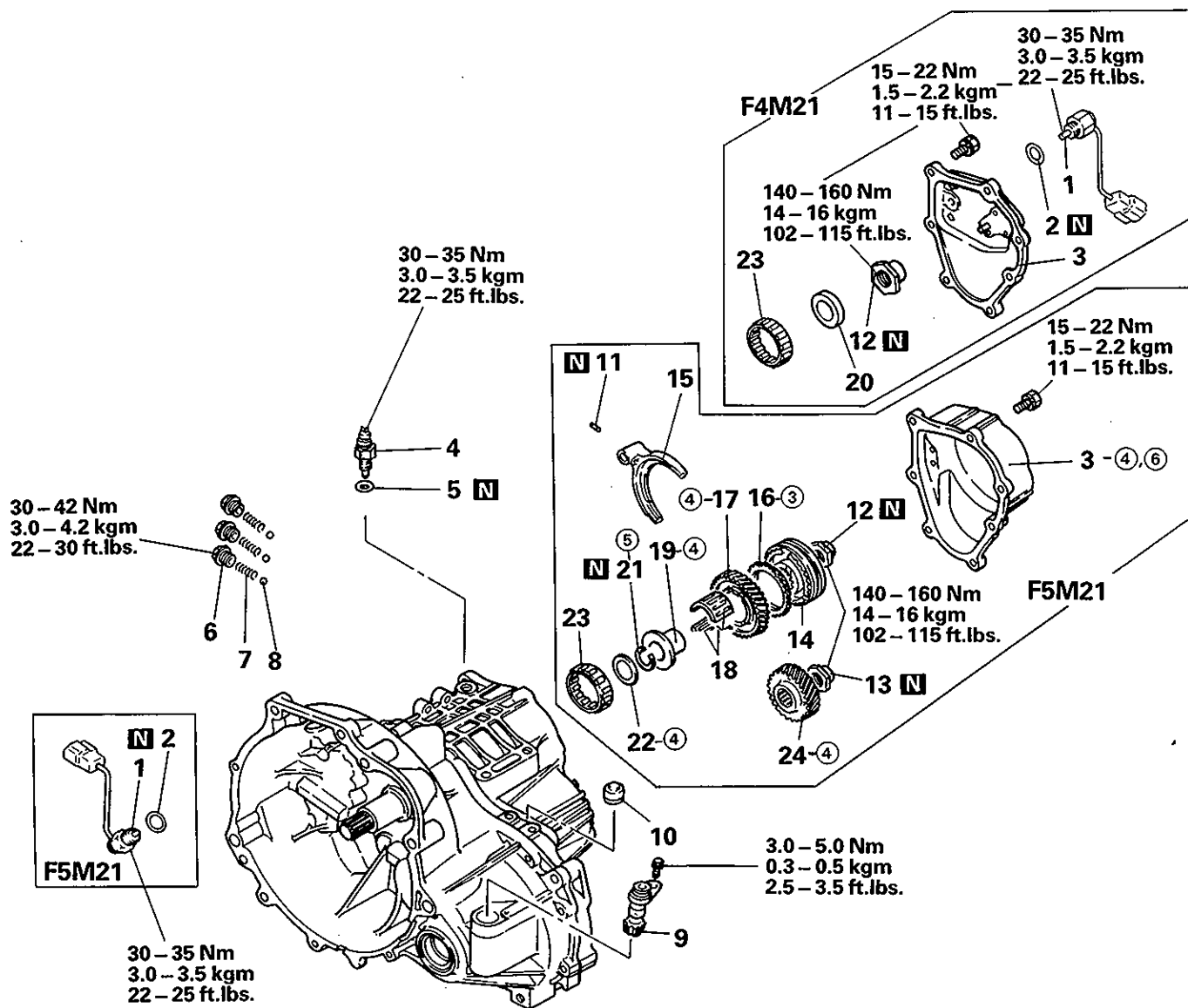

Disassembly steps

- | | |
|---|---|
| <ul style="list-style-type: none"> 1. Transmission switch 2. Gasket Q 3. Rear cover 4. Backup lamp switch 5. Gasket 6. Poppet plug 7. Poppet spring 8. Poppet ball 9. Speedometer driven gear assembly P 10. Air breather A B E N O 11. Spring pin N 12. Lock nut L 13. Lock nut 14. 5th speed synchronizer assembly | <ul style="list-style-type: none"> 15. 5th speed shift fork 16. Synchronizer ring 17. 5th speed gear 18. Needle bearing 19. Bearing sleeve M L 20. Dished washer 21. Snap ring (From DEC. 1987 – F5M21) 22. Spacer 23. Roller bearing 24. 5th speed intermediate gear |
|---|---|

NOTE

③④⑤⑥: Refer to "Details of Change" table.

F4M21, F5M21

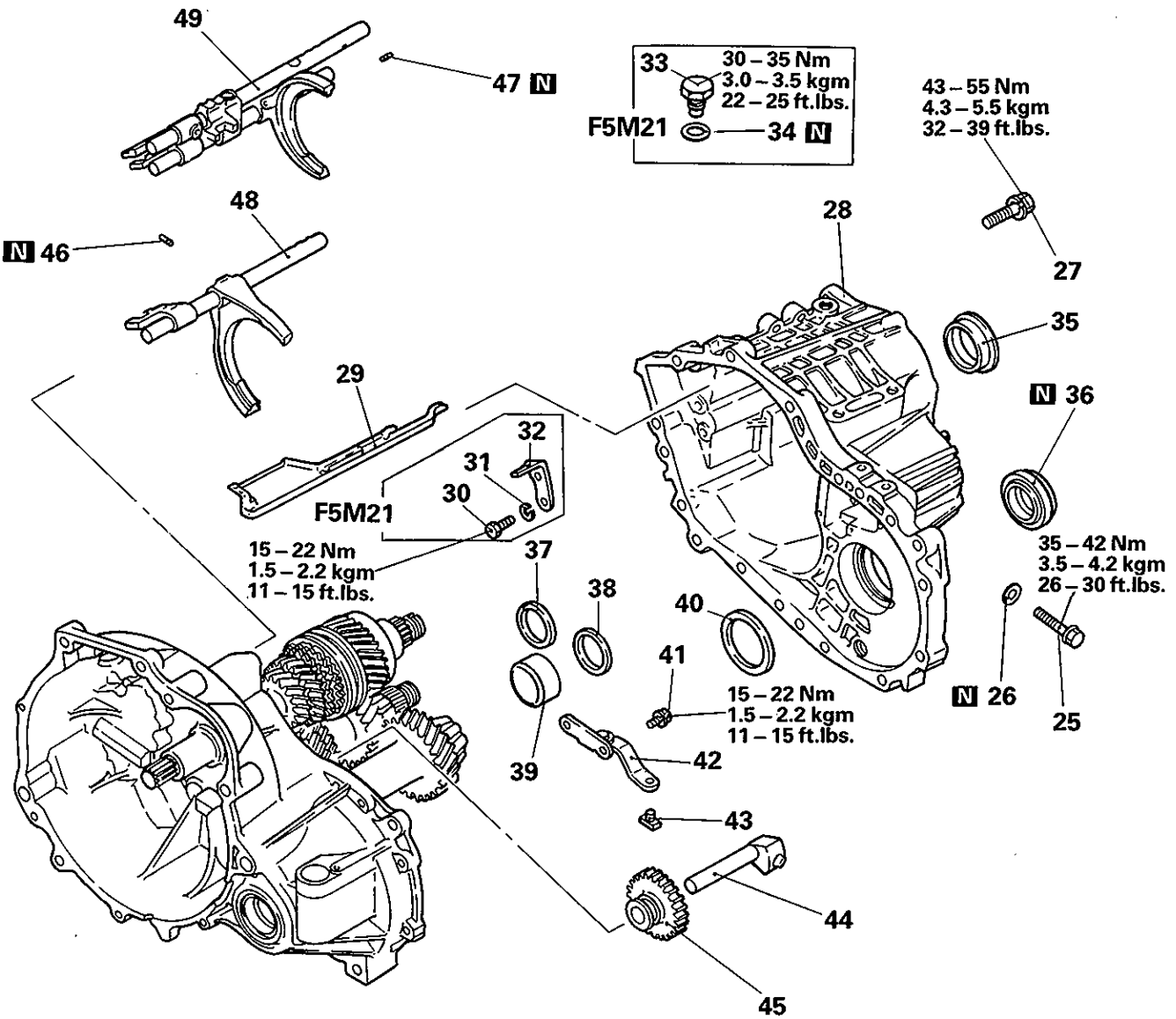

Disassembly steps

- K** 25. Reverse idler gear shaft bolt
- 26. Gasket
- 27. Bolt
- J** 28. Transmission case
- 29. Oil guide
- 30. Bolt
- 31. Spring washer
- 32. Stopper bracket
- 33. Restrict ball assembly
- 34. Gasket
- 35. Outer ring
- I** 36. Oil seal
- H** 37. Spacer
- H** 38. Spacer
- 39. Bearing outer race (From JUL. 1987)

- H** 40. Spacer
- 41. Bolt
- 42. Reverse shift lever assembly
- 43. Reverse shift lever shoe
- G** 44. Reverse idler gear shaft
- 45. Reverse idler gear
- C** 46. Spring pin
- F** 47. Spring pin
- D** 48. Shift rail assembly
- E** 49. Shift rail assembly

F4M21, F5M21

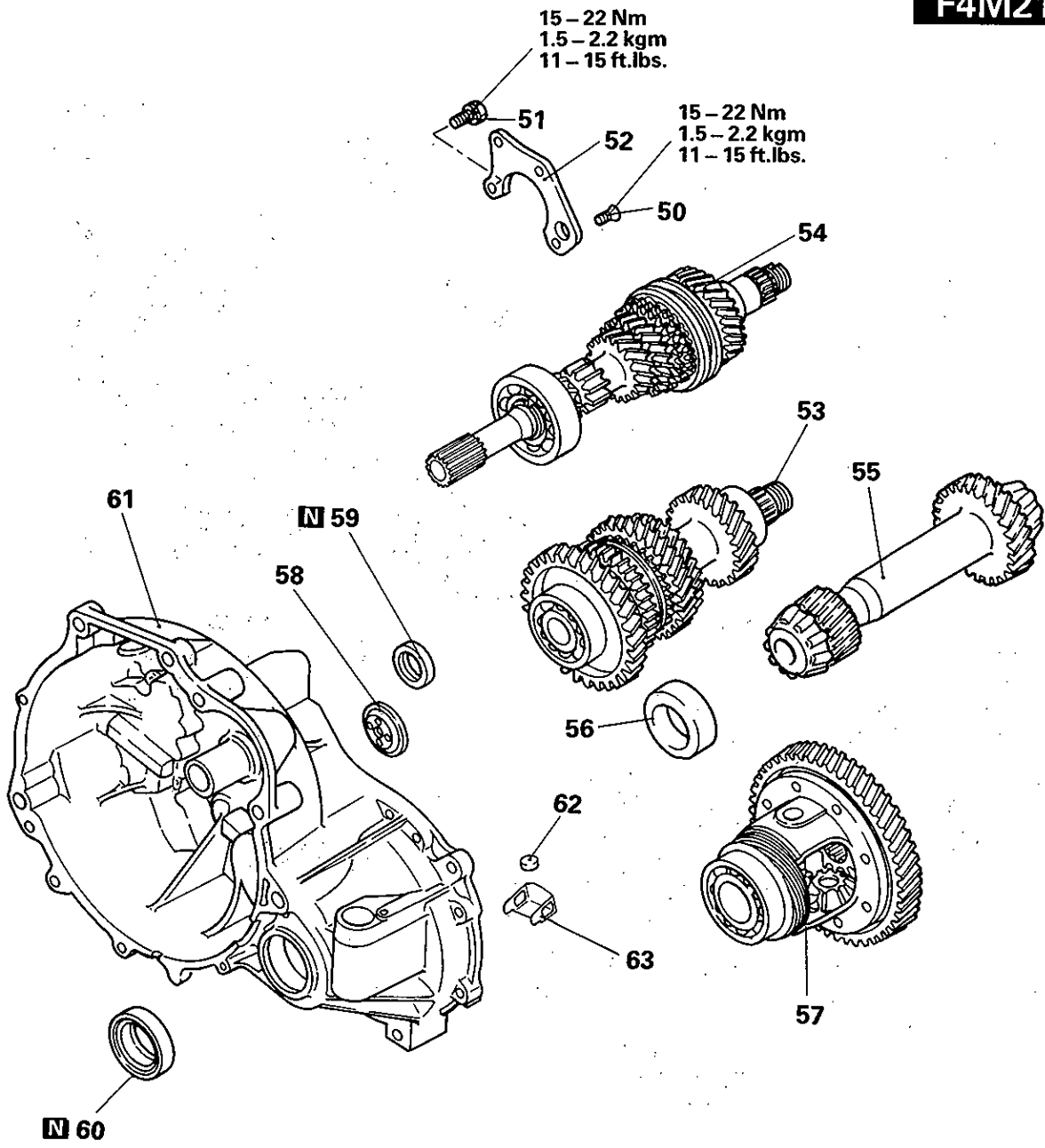

Disassembly steps

- D 50. Bolt
D 51. Bolt
E 52. Bearing retainer
- E C 53. Intermediate gear assembly
E C 54. Input shaft assembly
E 55. Output shaft assembly
E 56. Bearing outer race (From JUL. 1987)
E 57. Differential gear assembly
E 58. Oil guide
E 59. Oil seal
B A 60. Oil seal
B 61. Clutch housing assembly
B 62. Magnet
B 63. Magnet holder

F5M22

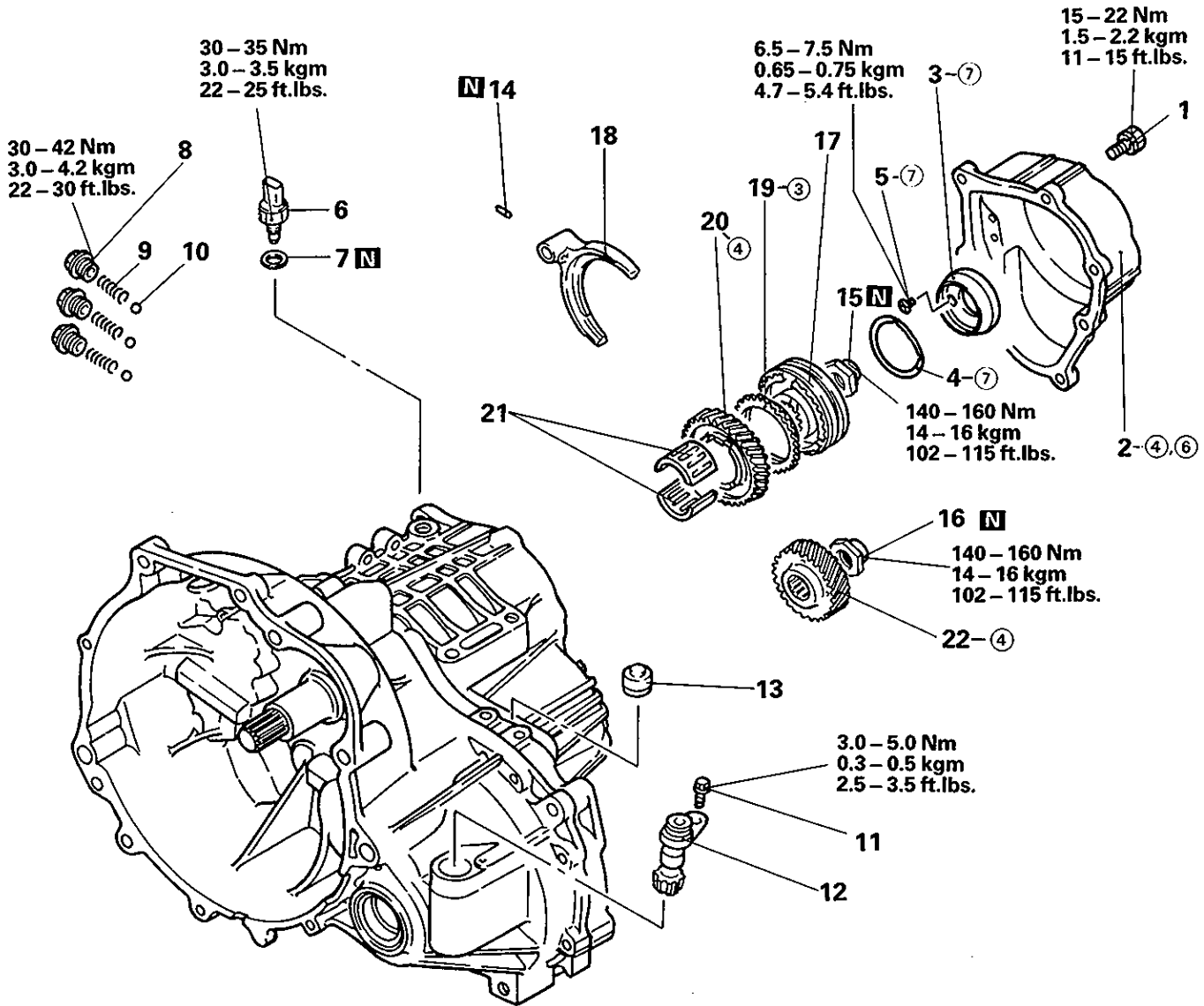

Disassembly steps

- 1. Bolt
- Q** 2. Rear cover
- 3. Reverse brake cone
- Z** 4. Wave spring
- R** 5. Machine screw
- 6. Backup lamp switch
- 7. Gasket
- 8. Poppet plug
- 9. Poppet spring
- 10. Poppet ball
- 11. Bolt
- 12. Speedometer driven gear assembly
- P** 13. Air breather
- A** 14. Spring pin
- B** 15. Lock nut
- B** 16. Lock nut

- 17. 5th speed synchronizer assembly
- 18. 5th speed shift fork
- 19. Synchronizer ring
- 20. 5th speed gear
- 21. Needle bearing
- 22. 5th speed intermediate gear

NOTE

③④⑥⑦: Refer to "Details of Change" table.

F5M22

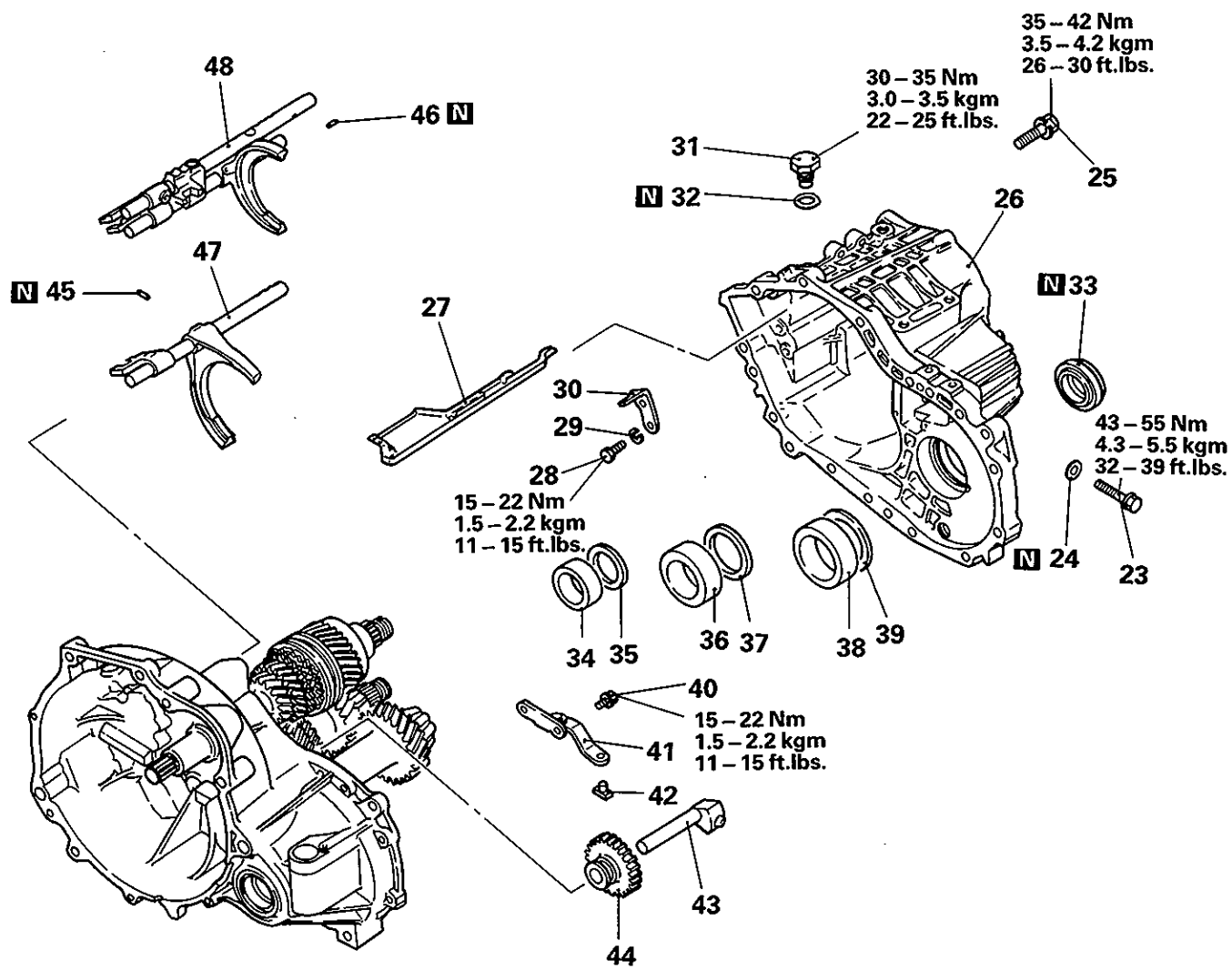

Disassembly steps

- K** 23. Reverse idler gear shaft bolt
- 24. Gasket
- 25. Bolt
- J** 26. Transmission case
- 27. Oil guide
- 28. Bolt
- 29. Spring washer
- 30. Stopper bracket
- 31. Restrict ball assembly
- 32. Gasket
- I** 33. Oil seal
- 34. Bearing outer race

- H** 35. Spacer
- 36. Bearing outer race
- H** 37. Spacer
- 38. Bearing outer race
- H** 39. Spacer
- 40. Bolt
- 41. Reverse shift lever assembly
- 42. Reverse shift lever shoe
- G** 43. Reverse idler gear shaft
- 44. Reverse idler gear
- C** **F** 45. Spring pin
- C** **F** 46. Spring pin
- D** **E** 44. Shift rail assembly
- D** **E** 48. Shift rail assembly

F5M22

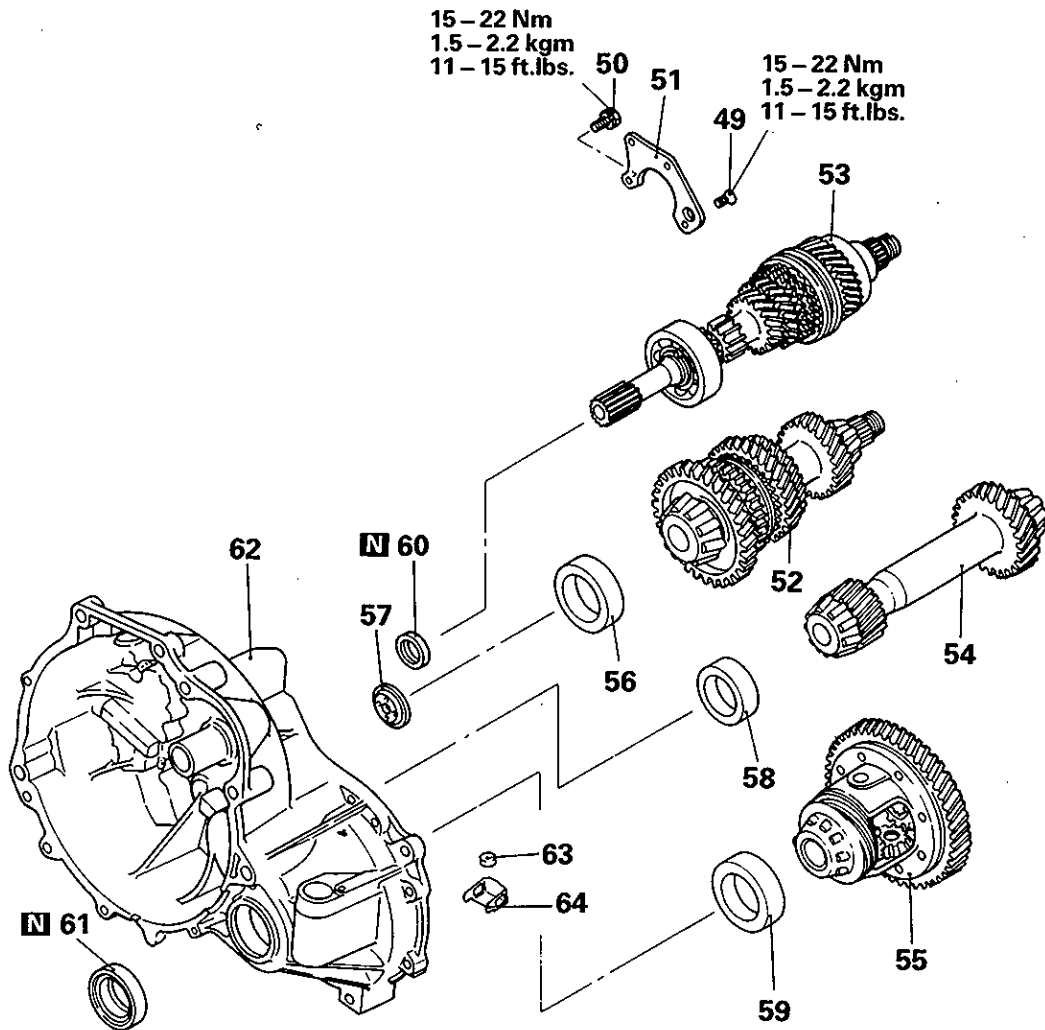
**Disassembly steps**

- | | |
|---|--|
| <p>D 49. Bolt</p> <p>50. Bolt</p> <p>51. Bearing retainer</p> <p>E C 52. Intermediate gear assembly</p> <p>E C 53. Input shaft assembly</p> <p>54. Output shaft assembly</p> <p>55. Differential gear assembly</p> <p>56. Bearing outer race</p> | <p>57. Oil guide</p> <p>58. Bearing outer race</p> <p>59. Bearing outer race</p> <p>B A 60. Oil seal</p> <p>61. Oil seal</p> <p>62. Clutch housing assembly</p> <p>63. Magnet</p> <p>64. Magnet holder</p> |
|---|--|

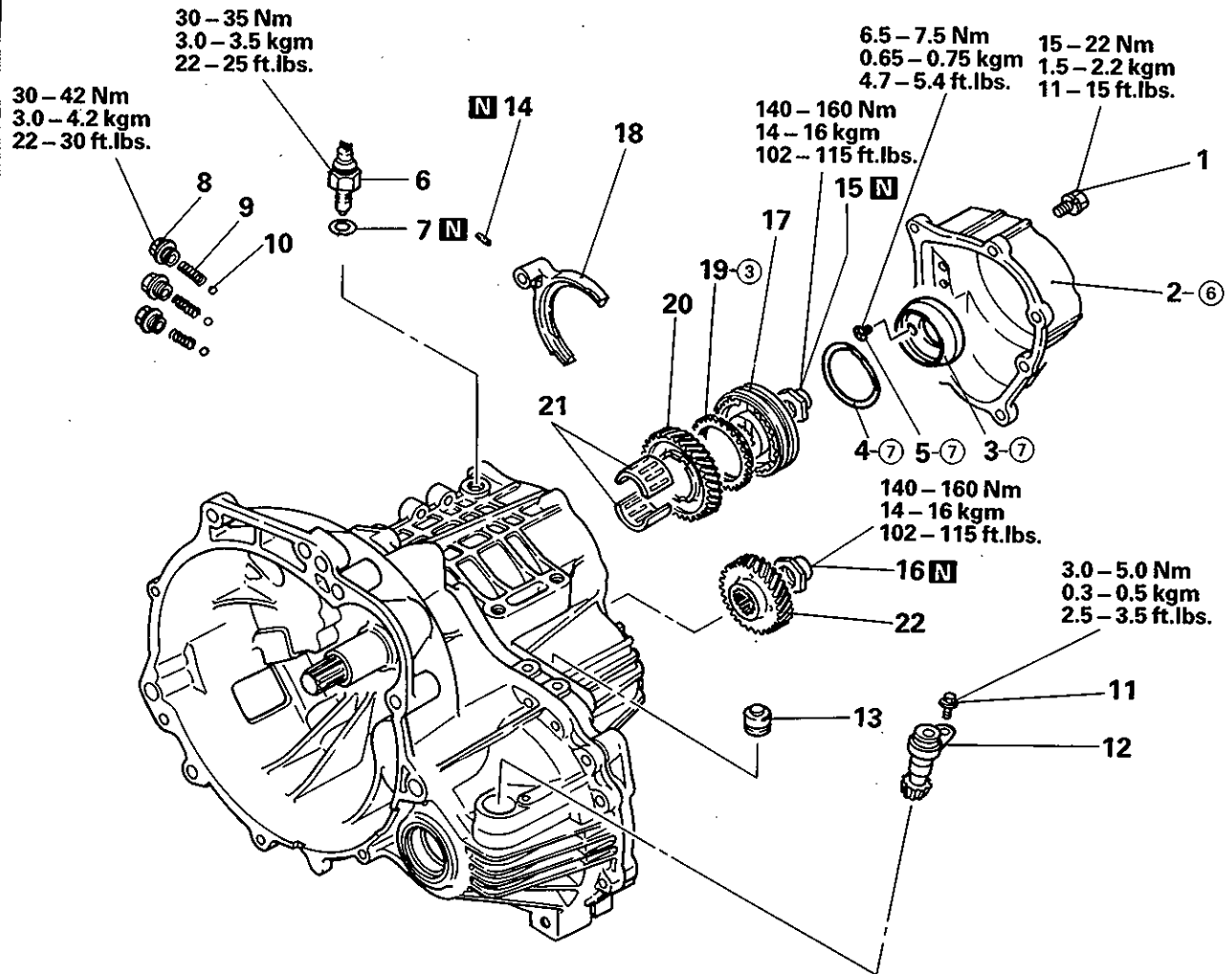

Disassembly steps

- 1. Bolt
- Q** 2. Rear cover
- 3. Reverse brake cone
- Z** 4. Wave spring
- R** 5. Machine screw
- 6. Back up lamp switch
- 7. Gasket
- 8. Poppet plug
- 9. Poppet spring
- 10. Poppet ball
- 11. Bolt
- 12. Speedometer driven gear assembly

- P** 13. Air breather
- A** 14. Spring pin
- B** 15. Lock nut
- N** 16. Lock nut
- O** 17. 5th speed synchronizer assembly
- N** 18. 5th speed shift fork
- N** 19. Synchronizer ring
- N** 20. 5th speed gear
- N** 21. Needle bearing
- N** 22. 5th speed intermediate gear

NOTE
(3)(6)(7): Refer to "Details of Change" table.

F5M31

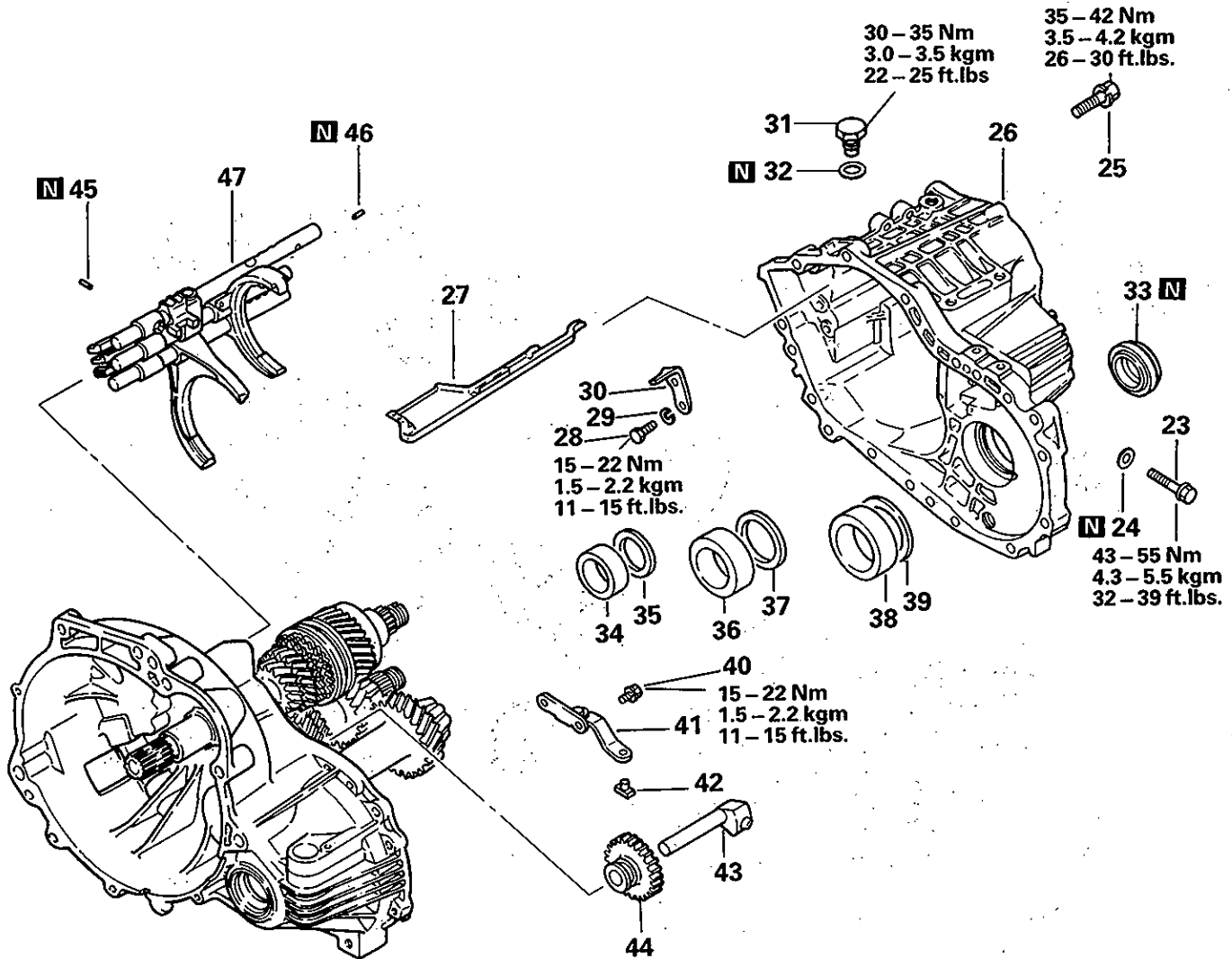

Disassembly steps

- | | |
|--|---|
| <p>K 23. Reverse idler gear shaft bolt</p> <p>24. Gasket</p> <p>25. Bolt</p> <p>J 26. Transmission case</p> <p>27. Oil guide</p> <p>28. Bolt</p> <p>29. Spring washer</p> <p>30. Stopper bracket</p> <p>31. Restrict ball assembly</p> <p>32. Gasket</p> <p>I 33. Oil seal</p> <p>34. Bearing outer race</p> <p>H 35. Spacer</p> | <p>36. Bearing outer race</p> <p>H 37. Spacer</p> <p>38. Bearing outer race</p> <p>H 39. Spacer</p> <p>40. Bolt</p> <p>41. Reverse shift lever assembly</p> <p>42. Reverse shift lever shoe</p> <p>G 43. Reverse idler gear shaft</p> <p>44. Reverse idler gear</p> <p>C F 45. Spring pin</p> <p>C F 46. Spring pin</p> <p>C E 47. Shift rail assembly</p> |
|--|---|

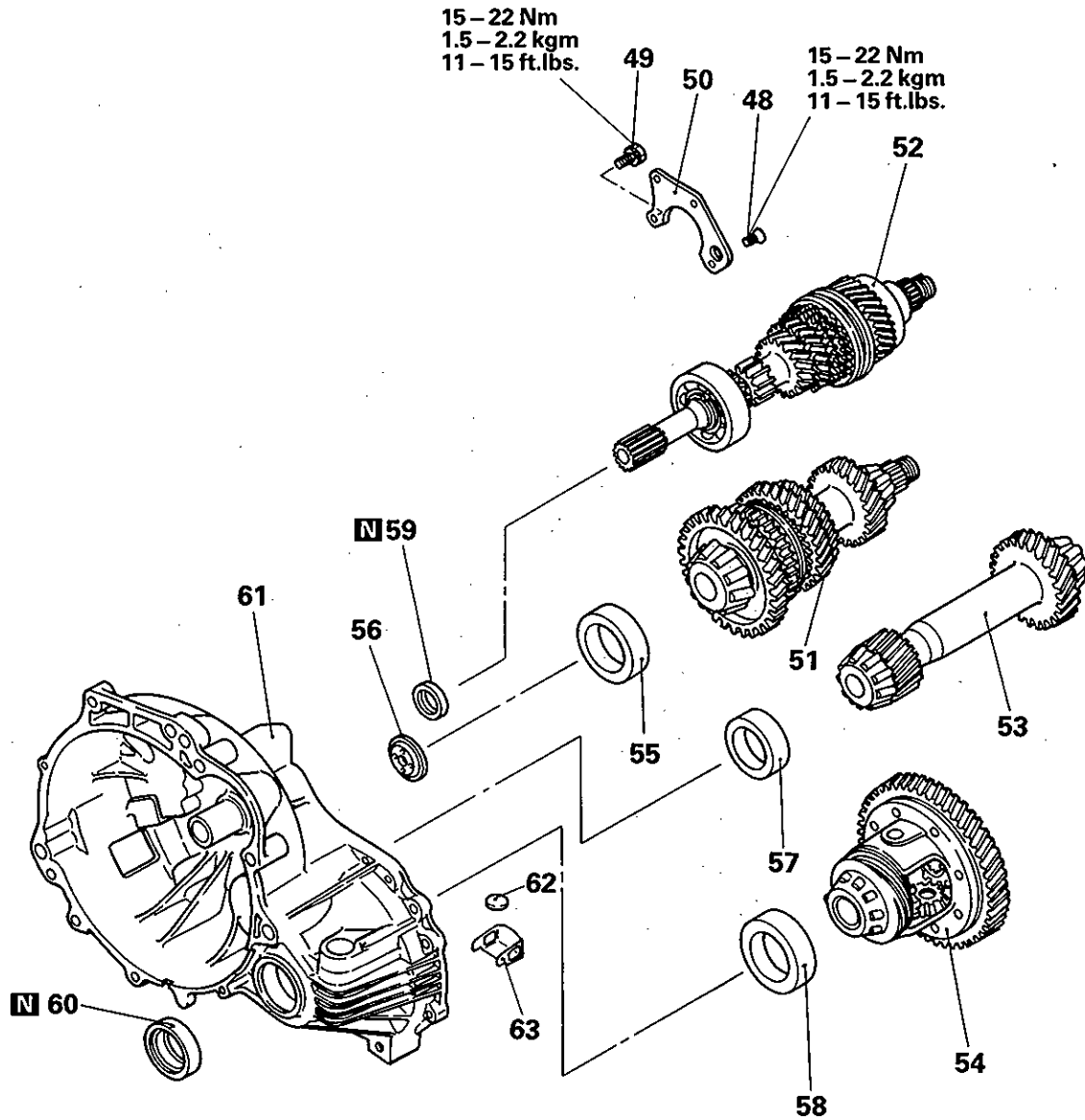

Disassembly steps

- | | |
|---|--|
| <p>[D] 48. Bolt
49. Bolt</p> <p>[D] [C] 51. Intermediate gear assembly
[D] [C] 52. Input shaft assembly</p> | <p>56. Oil guide
57. Bearing outer race
58. Bearing outer race</p> <p>[B] [A] 59. Oil seal
60. Oil seal
61. Clutch housing assembly
62. Magnet
63. Magnet holder</p> |
|---|--|

F5M33

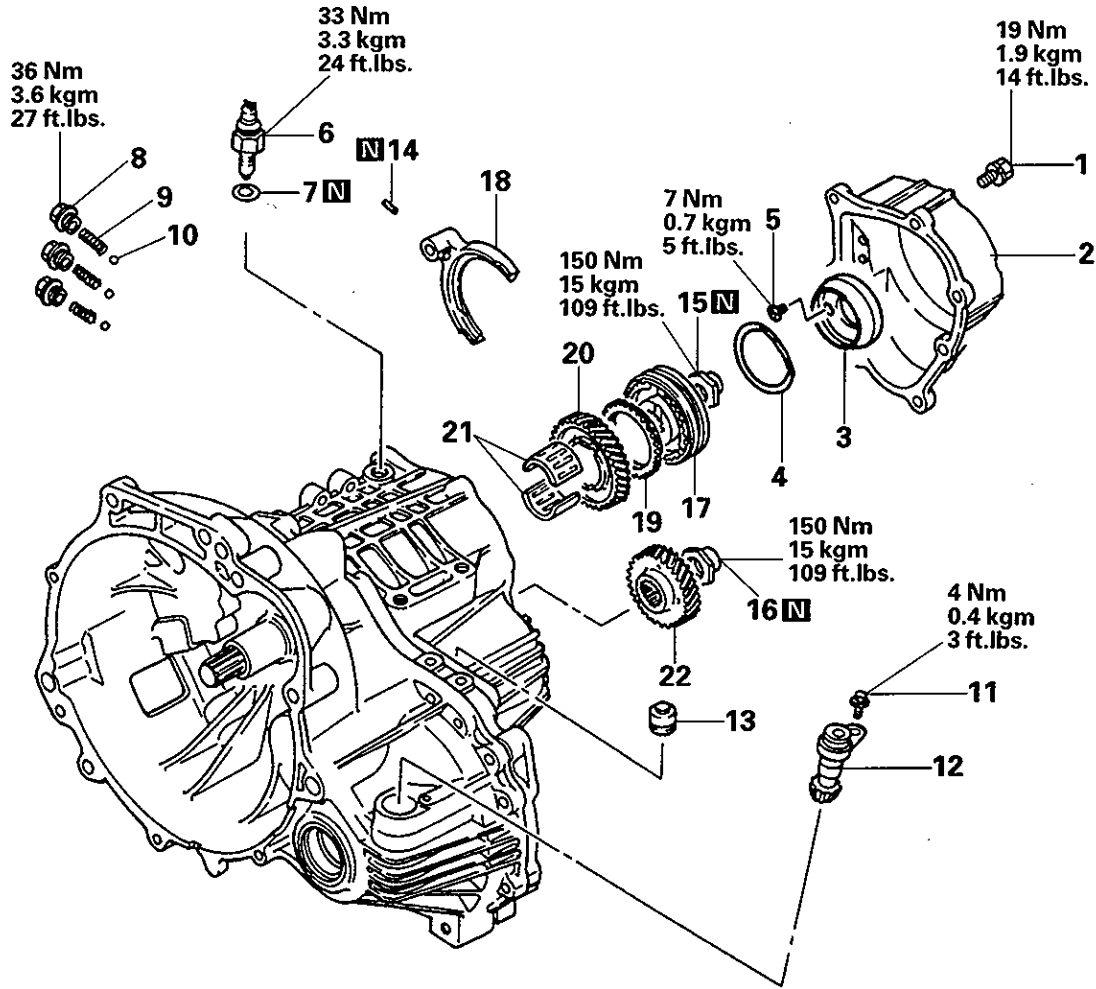

Disassembly steps

- | | |
|---|--|
| <ul style="list-style-type: none"> 1. Bolt Q 2. Rear cover 3. Reverse brake cone 4. Wave spring Z 5. Machine screw R 6. Back up light switch 7. Gasket 8. Poppet plug 9. Poppet spring 10. Poppet ball 11. Bolt | <ul style="list-style-type: none"> 12. Speedometer driven gear assembly 13. Air breather P 14. Spring pin A 15. Lock nut B 16. Lock nut 17. 5th speed synchronizer assembly 18. 5th speed shift fork 19. Synchronizer ring 20. 5th speed gear 21. Needle bearing 22. 5th speed intermediate gear |
|---|--|

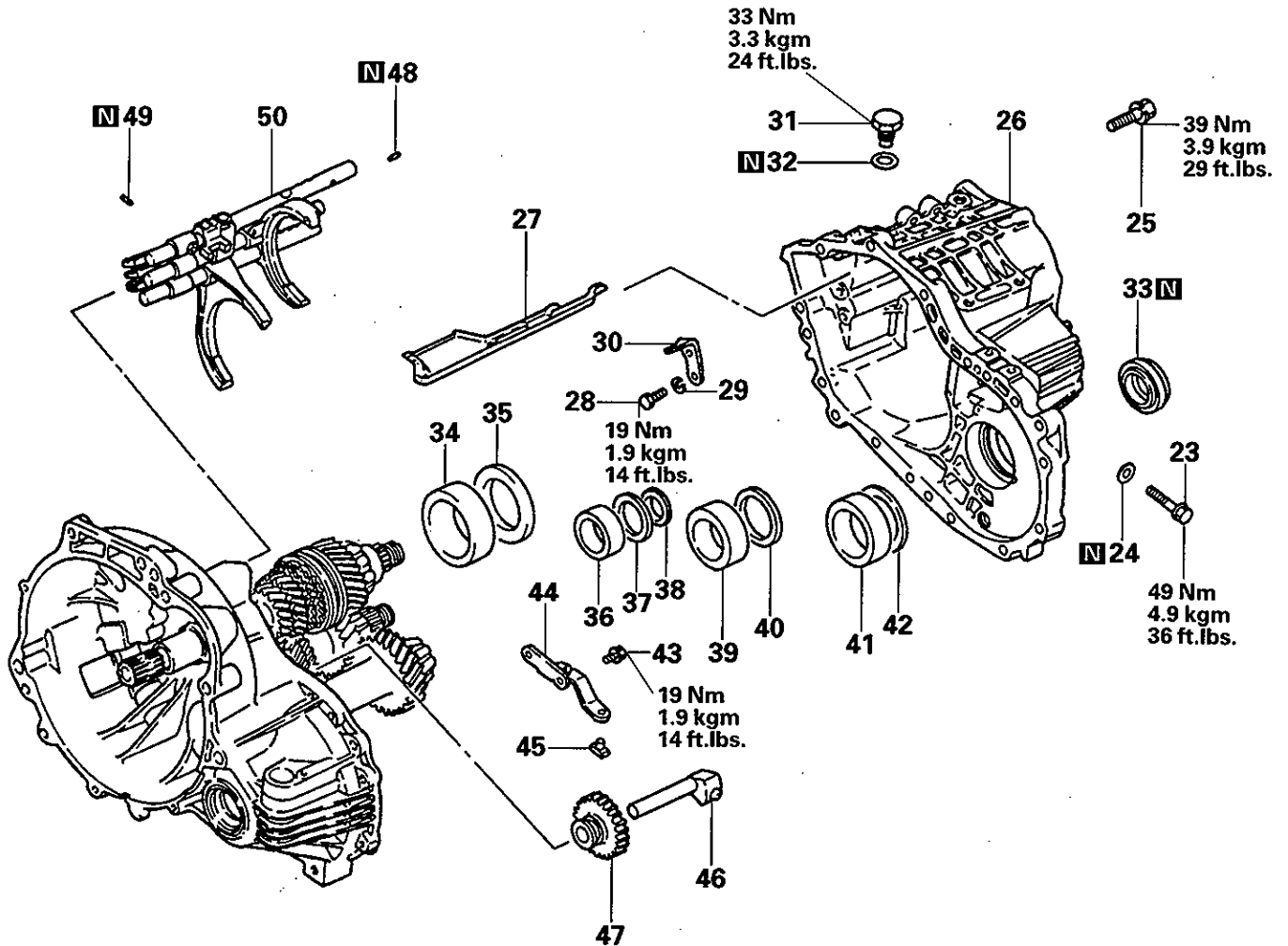

Disassembly steps

- K** 23. Reverse idler gear shaft bolt
- 24. Gasket
- 25. Bolt
- J** 26. Transmission case
- 27. Oil guide
- 28. Bolt
- 29. Spring washer
- 30. Stopper bracket
- 31. Restrict ball assembly
- Gasket
- I** 33. Oil seal
- 34. Bearing outer race
- H** 35. Spacer
- 36. Bearing outer race

- H** 37. Spacer
- 38. Filter
- 39. Bearing outer race
- H** 40. Spacer
- 41. Bearing outer race
- H** 42. Spacer
- 43. Bolt
- 44. Reverse shift lever assembly
- 45. Reverse shift lever shoe
- G** 46. Reverse idler gear shaft
- 47. Reverse idler gear
- F** 48. Spring pin
- F** 49. Spring pin
- C** **F** 50. Shift rail assembly

F5M33

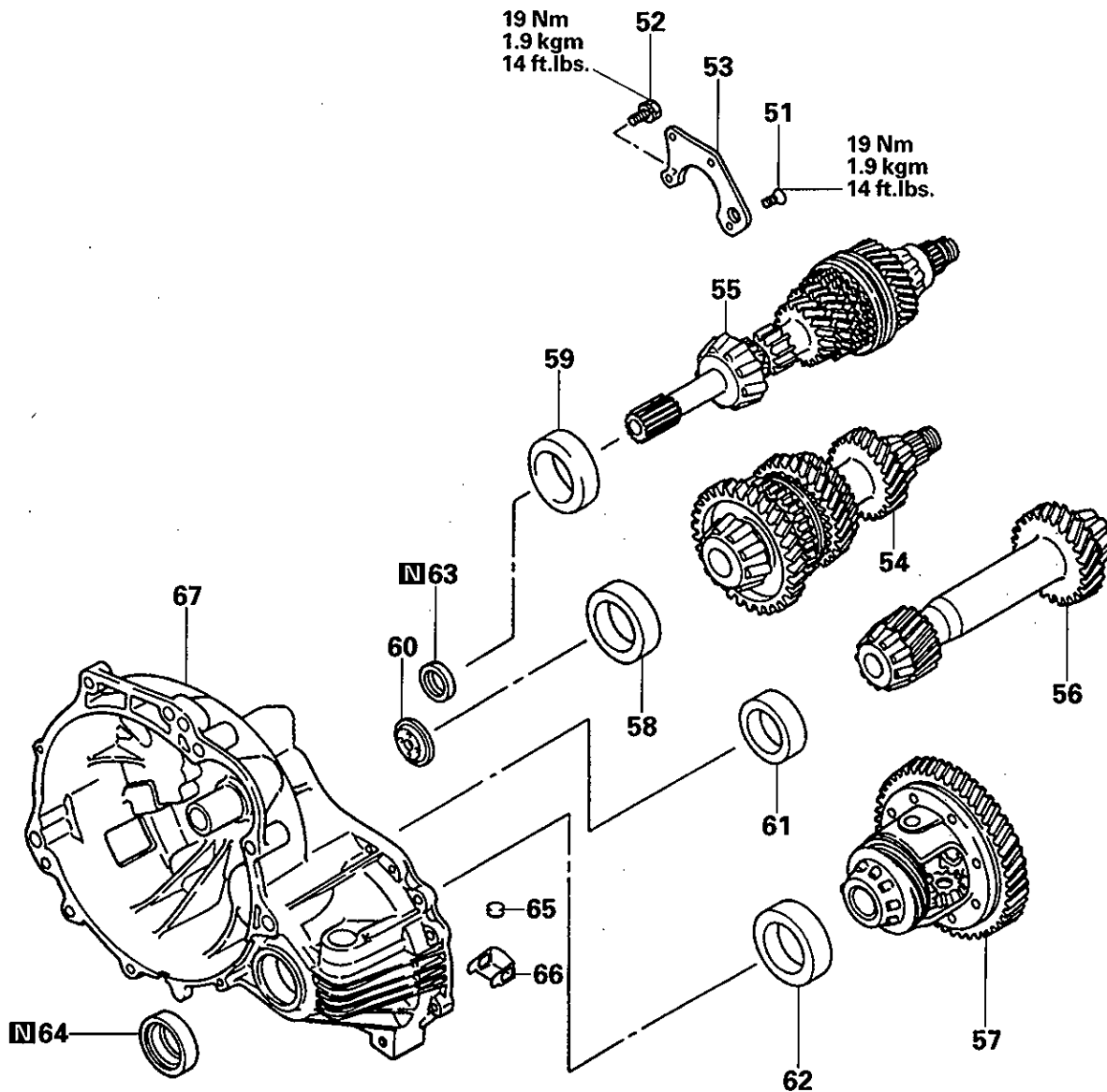

Disassembly steps

- D** 51. Bolt
- 52. Bolt
- E** **C** 53. Bearing retainer
- E** **C** 54. Intermediate gear assembly
- 55. Input shaft assembly
- 56. Output shaft assembly
- 57. Differential gear assembly
- 58. Bearing outer race
- 59. Bearing outer race

- 60. Oil guide
- 61. Bearing outer race
- 62. Bearing outer race
- B** **A** 63. Oil seal
- 64. Oil seal
- 65. Magnet
- 66. Magnet holder
- 67. Clutch housing assembly

Intentionally blank

W5M31

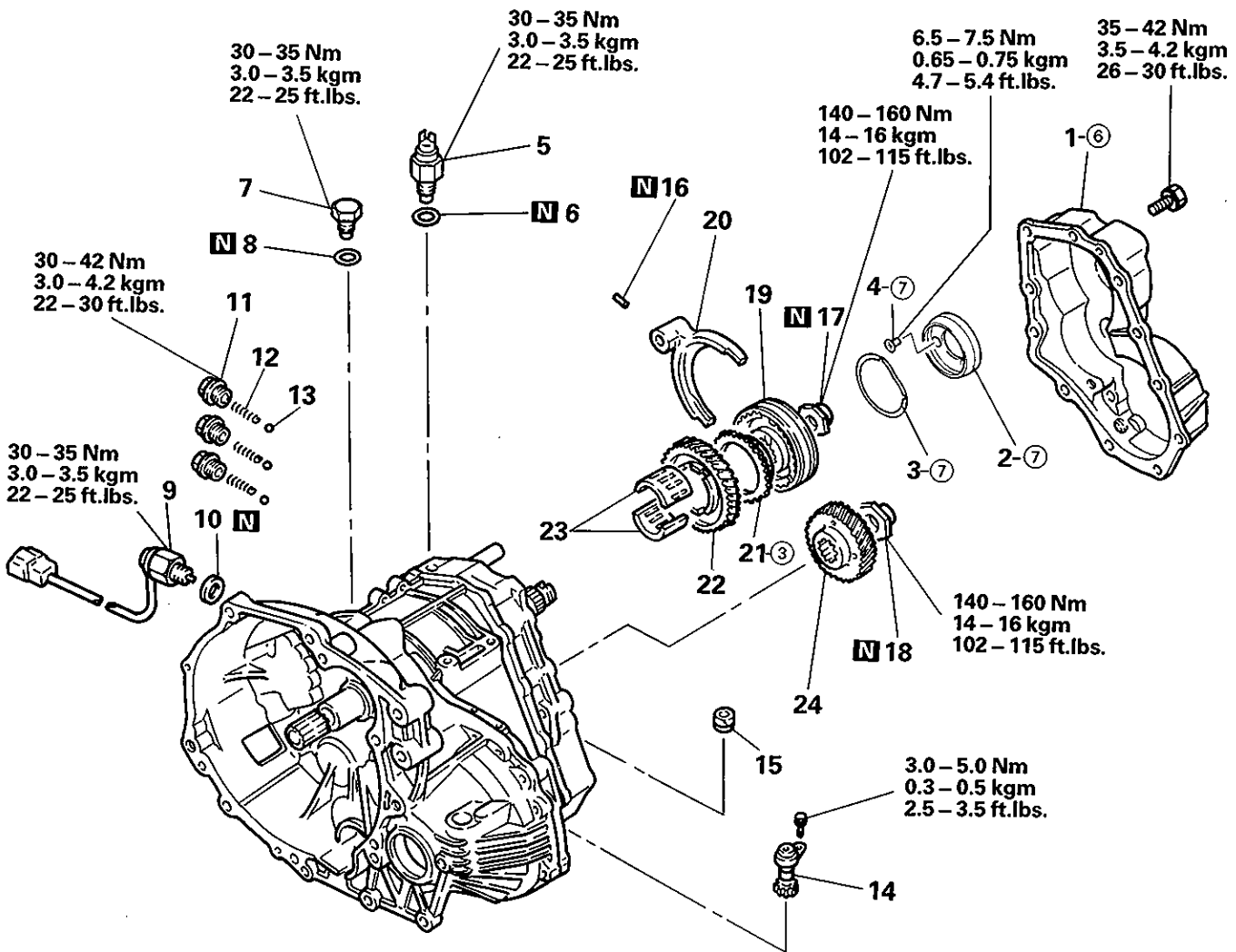

Disassembly steps

- | | |
|---|--|
| <p>Q 1. Rear cover</p> <p>Z 2. Reverse brake cone</p> <p>R 3. Wave spring</p> <p>4. Machine screw</p> <p>5. Backup lamp switch</p> <p>6. Gasket</p> <p>7. Restrict ball assembly</p> <p>8. Gasket</p> <p>9. Indicator lamp switch (with differential lock)</p> <p>10. Gasket (with differential lock)</p> <p>11. Poppet plug</p> <p>12. Poppet spring</p> <p>13. Poppet ball</p> <p>14. Speedometer driven gear assembly</p> | <p>A 15. Air breather</p> <p>B 16. Spring pin</p> <p>P 17. Lock nut</p> <p>N 18. Lock nut</p> <p>19. 5th speed synchronizer assembly</p> <p>20. Shift fork</p> <p>21. Synchronizer ring</p> <p>22. 5th speed gear</p> <p>23. Needle bearing</p> <p>24. 5th speed intermediate gear</p> |
|---|--|

NOTE
 ③⑥: Refer to "Details of Change" table.

Provided with viscous coupling

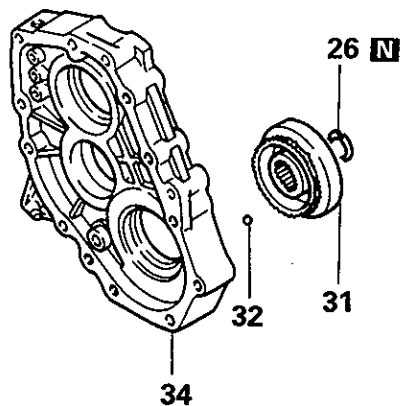

Provided with differential lock

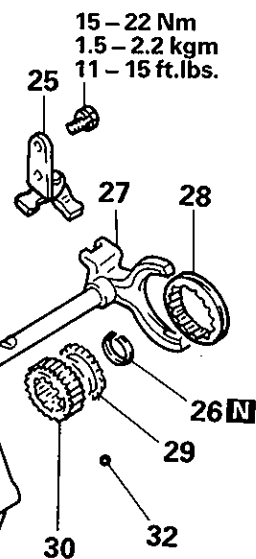

15 – 22 Nm
1.5 – 2.2 kgm
11 – 15 ft.lbs.

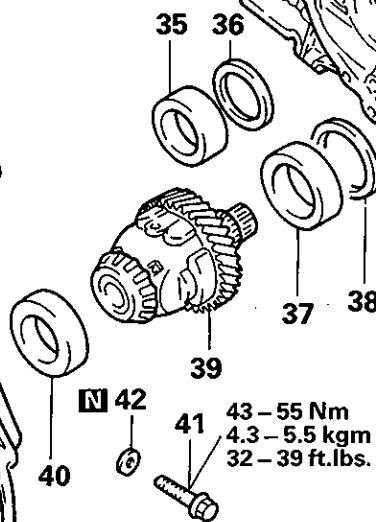
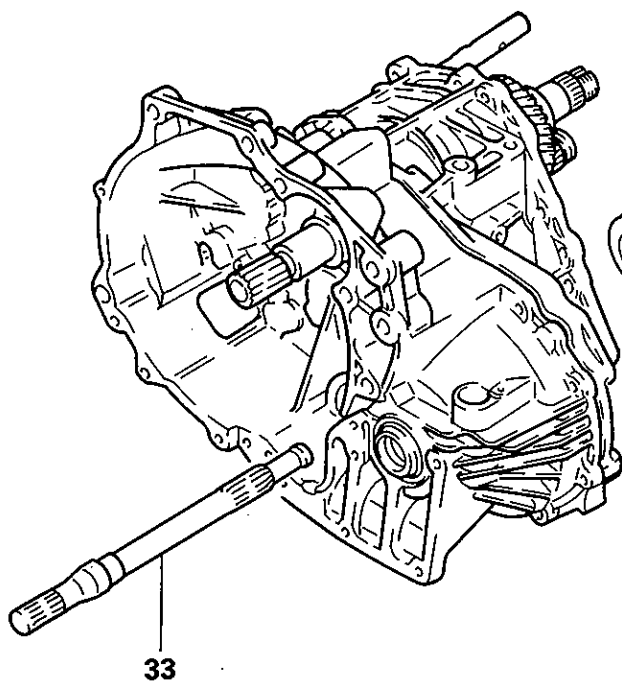

43 – 55 Nm
4.3 – 5.5 kgm
32 – 39 ft.lbs.

Disassembly steps

- 25. Differential lock shift lever
- Y** 26. Snap ring
- 27. Differential lock shift rail assembly
- 28. Clutch sleeve
- 29. Clutch gear
- 30. Differential lock hub
- 31. Viscous coupling
- X** 32. Steel ball
- 33. Center shaft

- W** 34. Transmission case adapter assembly
- V** 35. Bearing outer race
- V** 36. Spacer
- V** 37. Bearing outer race
- V** 38. Spacer
- F** 39. Center differential
- K** 40. Bearing outer race
- K** 41. Reverse idler gear shaft bolt
- F** 42. Gasket

W5M31

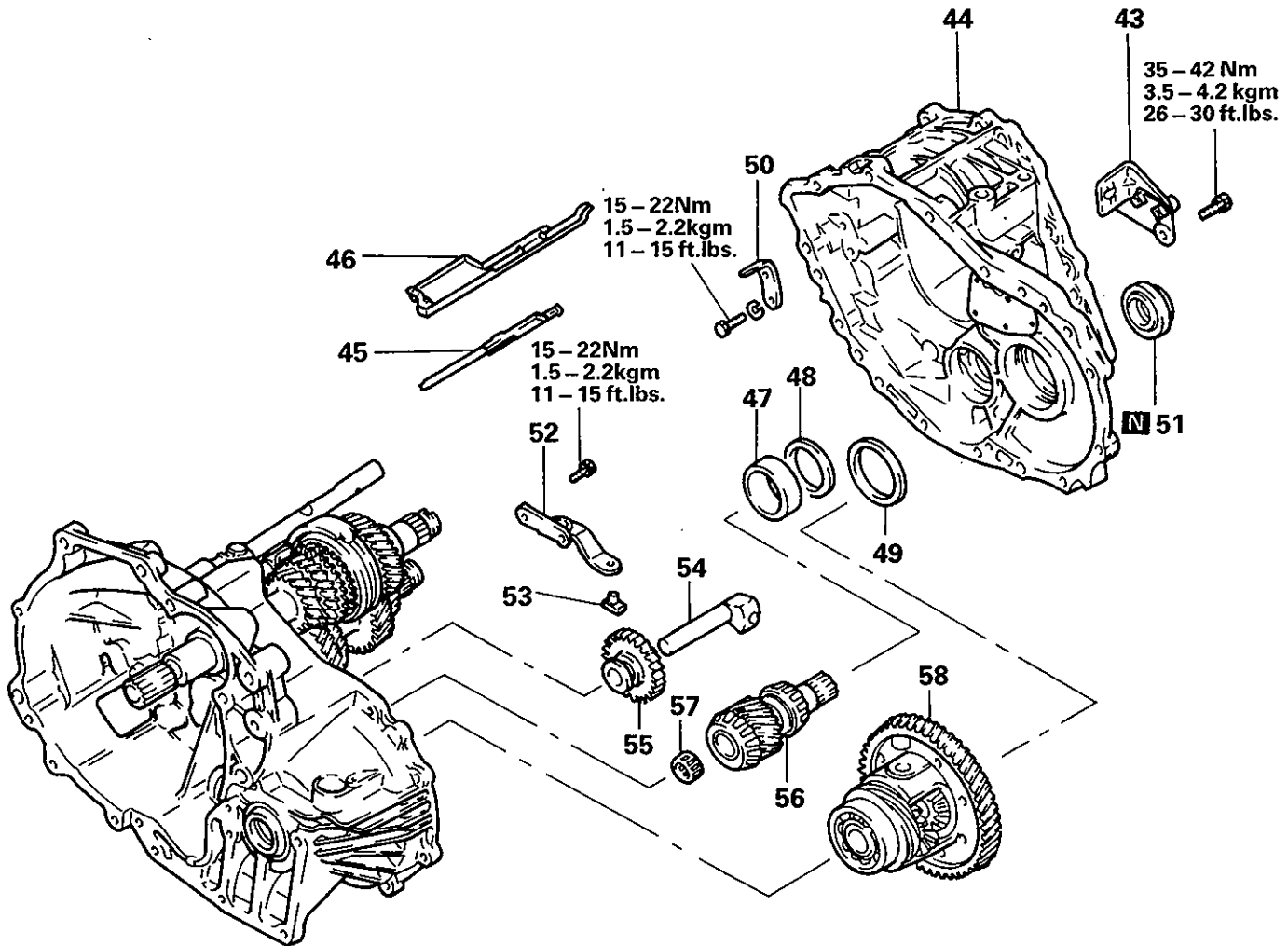
**Disassembly steps**

- 43. Clutch oil line bracket
- J** 44. Transmission case
- 45. Oil guide
- 46. Oil guide
- 47. Bearing outer race
- U** 48. Spacer
- U** 49. Spacer
- 50. Stopper bracket

- I** 51. Oil seal
- 52. Reverse shift lever assembly
- 53. Reverse shift lever shoe
- 54. Reverse idler gear shaft
- 55. Reverse idler gear
- 56. Front output shaft
- 57. Needle bearing
- 58. Front differential

W5M31

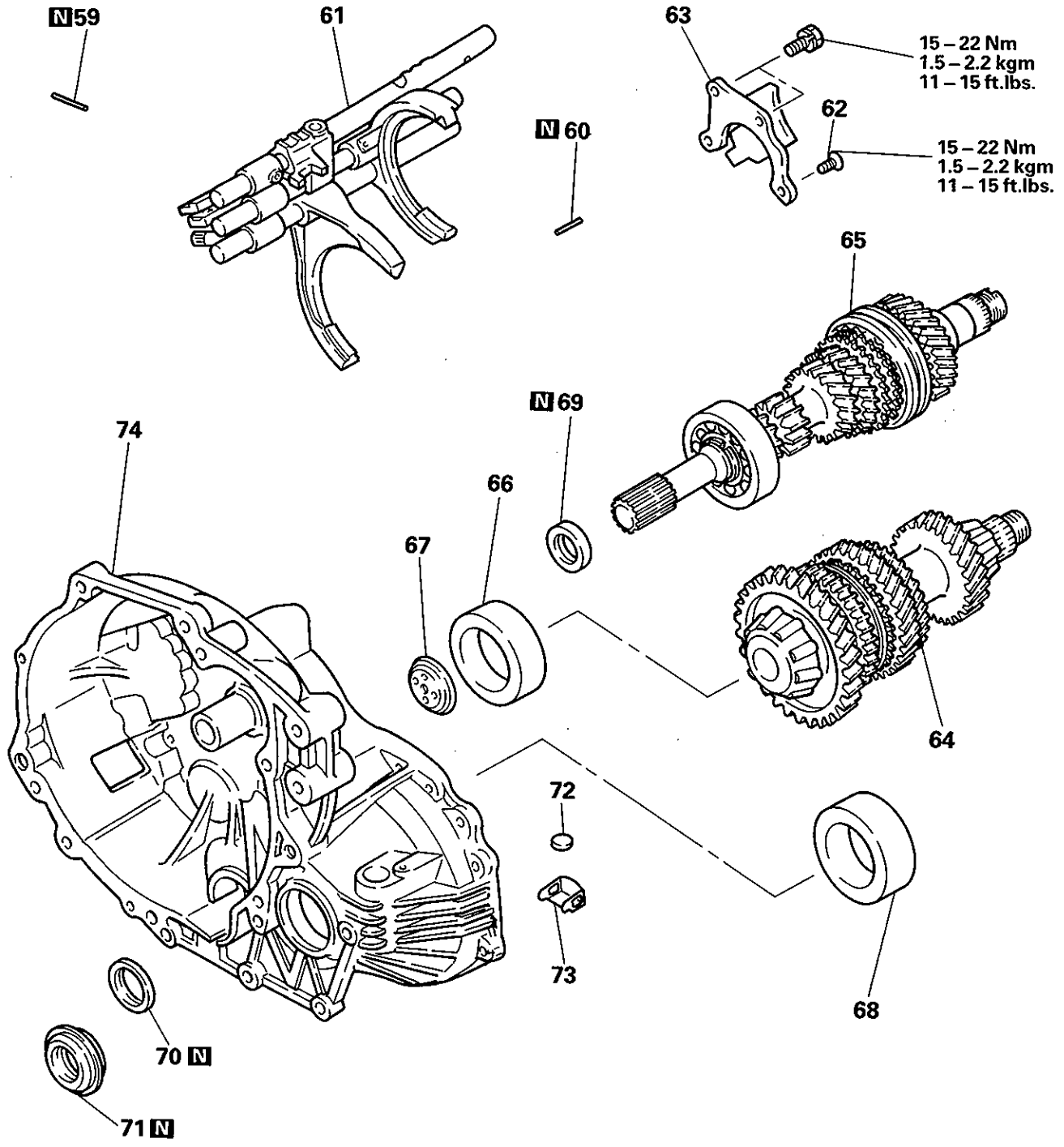

Disassembly steps

- Ⓒ **F** 59. Spring pin
- Ⓒ **F** 60. Spring pin
- Ⓓ **E** 61. Shift rail assembly
- Ⓓ **D** 62. Bolt
- Ⓔ 63. Bearing retainer
- Ⓔ **C** 64. Intermediate gear assembly
- Ⓔ **C** 65. Input shaft assembly
- Ⓔ **F** 66. Outer race

- Ⓔ 67. Oil guide
- Ⓔ **F** 68. Outer race
- Ⓔ **B** 69. Oil seal
- Ⓔ **S** 70. Oil seal
- Ⓔ **S** 71. Oil seal
- Ⓔ 72. Magnet
- Ⓔ 73. Magnet holder
- Ⓔ 74. Clutch housing

W5M33

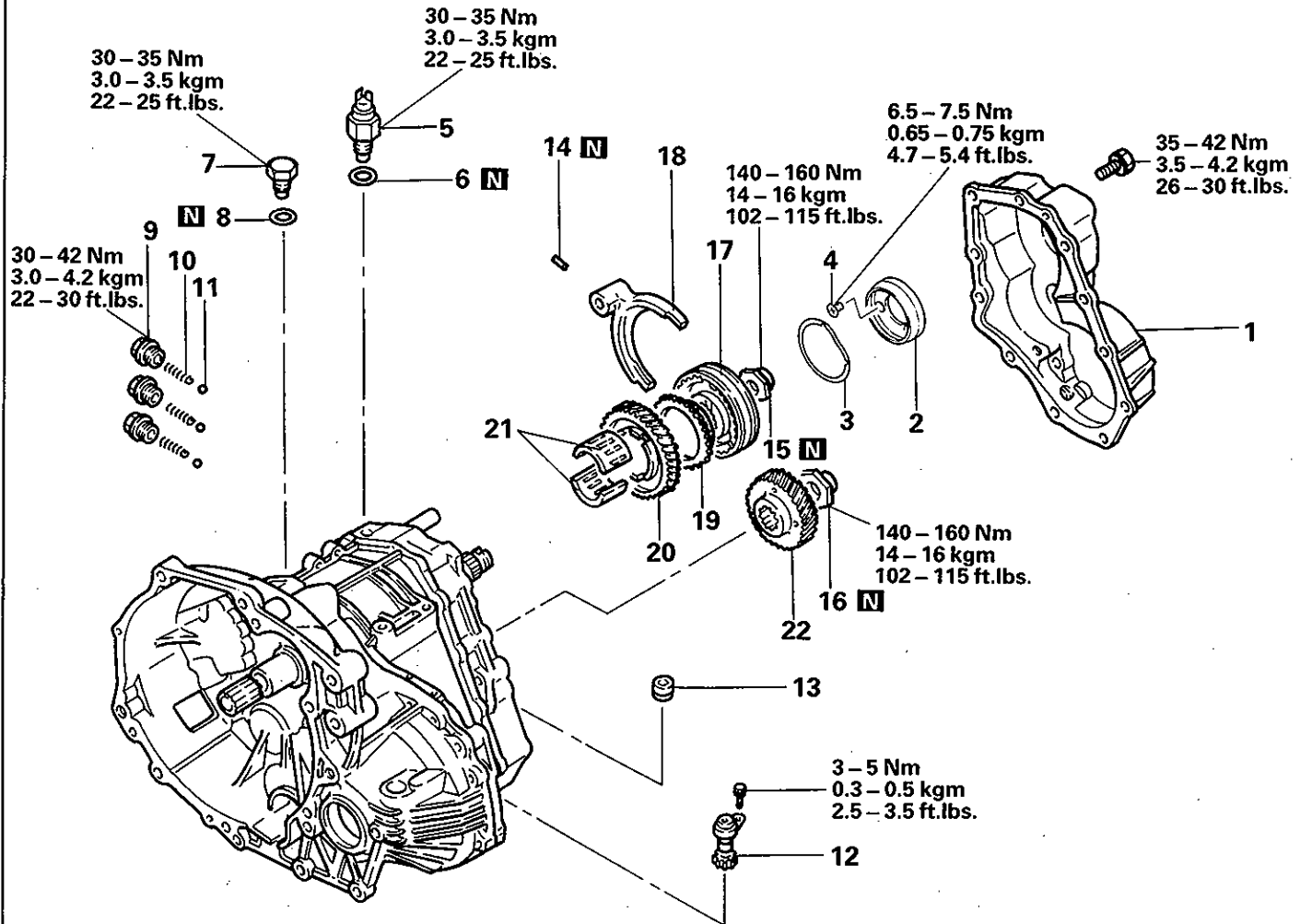

Disassembly steps

- Q** 1. Rear cover
- 2. Reverse brake cone
- R** 3. Wave spring
- Z** 4. Machine screw
- 5. Backup light switch
- 6. Gasket
- 7. Restrict ball assembly
- 8. Gasket
- 9. Poppet plug
- 10. Poppet spring
- 11. Poppet ball
- 12. Speedometer driven gear assembly
- P** 13. Air breather
- A** 14. Spring pin
- B** 15. Lock nut
- B** 16. Lock nut
- Z** 17. 5th speed synchronizer assembly
- N** 18. Shift fork
- O** 19. Synchronizer ring
- F** 20. 5th speed gear
- N** 21. Needle bearing
- P** 22. 5th speed intermediate gear

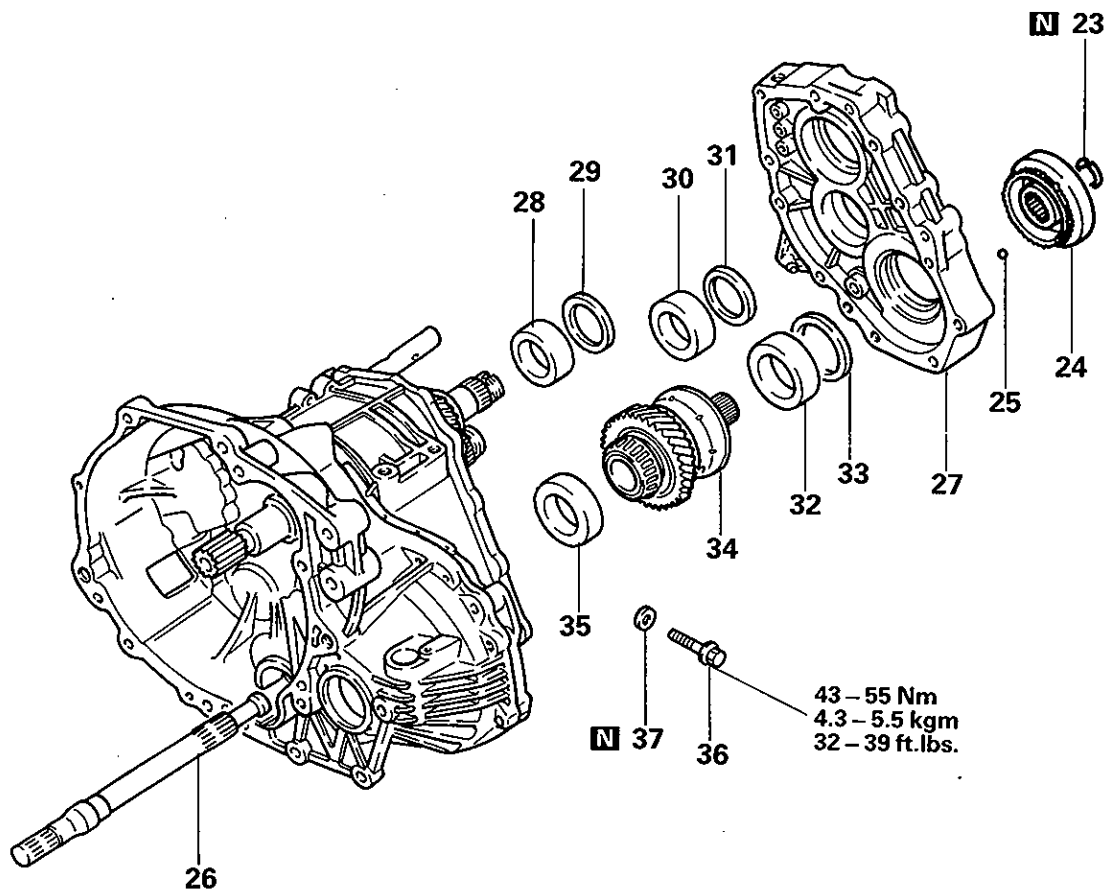

Disassembly steps

- 23. Snap ring
- 24. Viscous coupling
- 25. Steel ball
- 26. Center shaft
- 27. Transaxle case adapter
- 28. Outer case
- 29. Spacer
- 30. Outer race
- 31. Spacer
- 32. Outer race
- 33. Spacer
- 34. Center differential
- 35. Outer race
- 36. Reverse idler gear shaft bolt
- 37. Gasket

W5M33

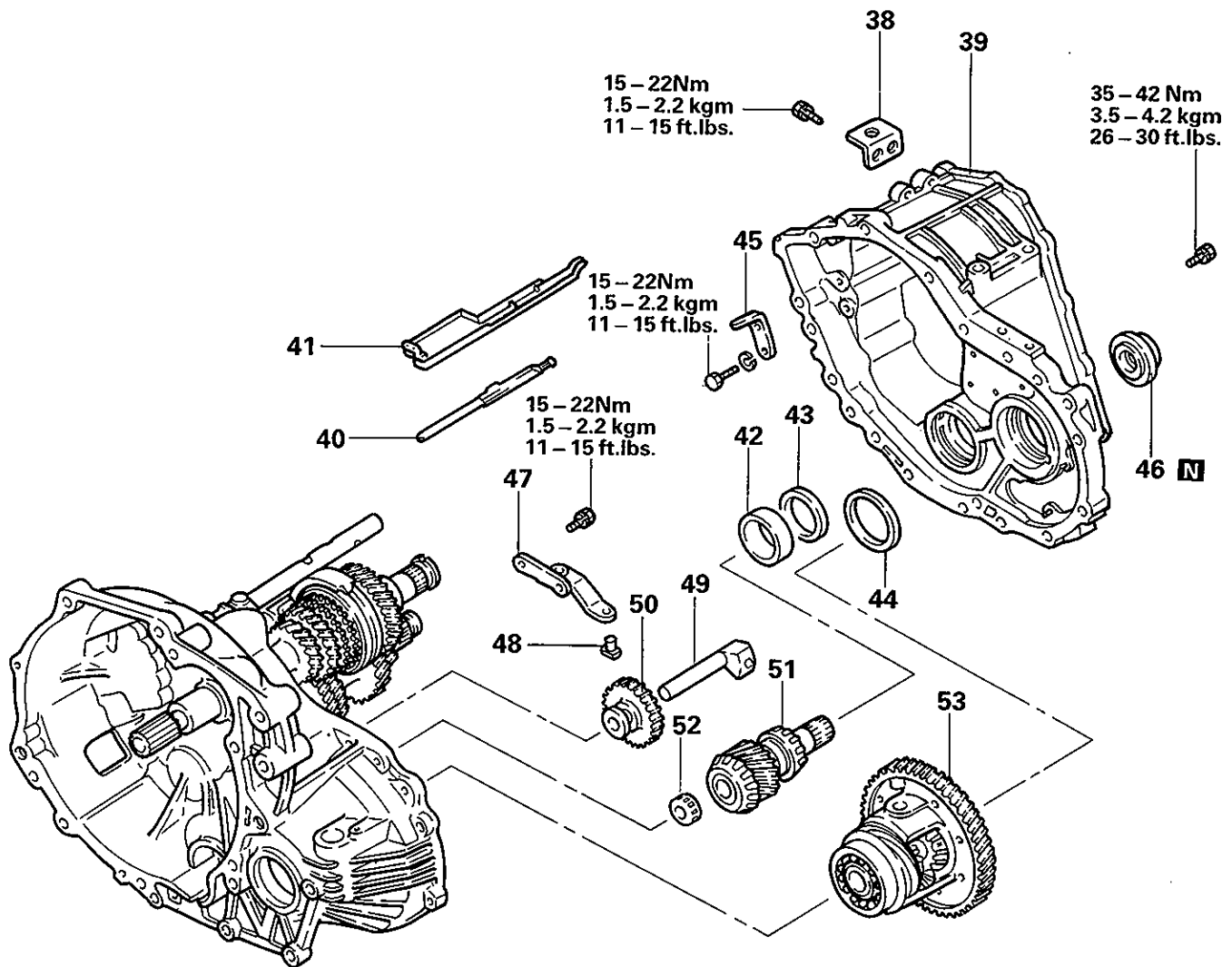

Disassembly steps

- 38. Clutch oil line bracket
- J** 39. Transaxle case
- 30. Oil guide
- 41. Oil guide
- 42. Outer race
- E** 43. Spacer
- E** 44. Spacer
- 45. Stopper bracket
- I** 46. Oil seal
- 47. Reverse shift lever assembly
- 48. Reverse shift lever shoe
- 49. Reverse idler gear shaft
- 50. Reverse idler gear
- 51. Front output shaft assembly
- 52. Needle bearing
- 53. Front differential

W5M33

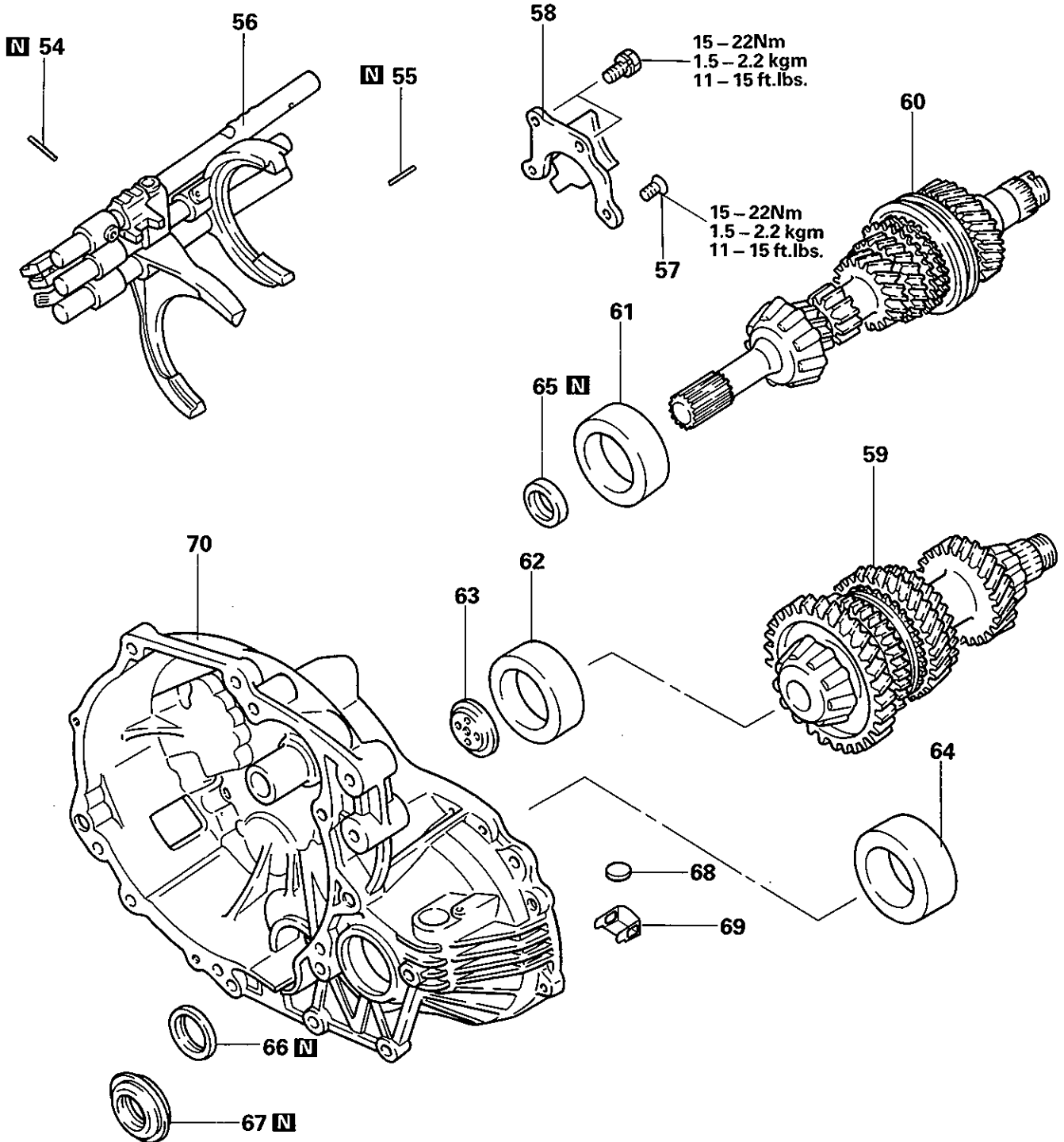

Disassembly steps

- (C) (F) 54. Spring pin
- (C) (F) 55. Spring pin
- (D) (E) 56. Shift rail assembly
- (D) 57. Bolt
- (E) 58. Bearing retainer
- (E) (C) 59. Intermediate gear assembly
- (E) (C) 60. Input shaft assembly
- (E) 61. Outer racer
- (F) 62. Outer race

- (F) 63. Oil guide
- (F) 64. Outer race
- (B) (T) (S) 65. Oil seal
- (B) (T) (S) 66. Oil seal
- (B) (T) (S) 67. Oil seal
- (F) 68. Magnet
- (F) 69. Magnet holder
- (F) 70. Clutch housing assembly

Details of Change

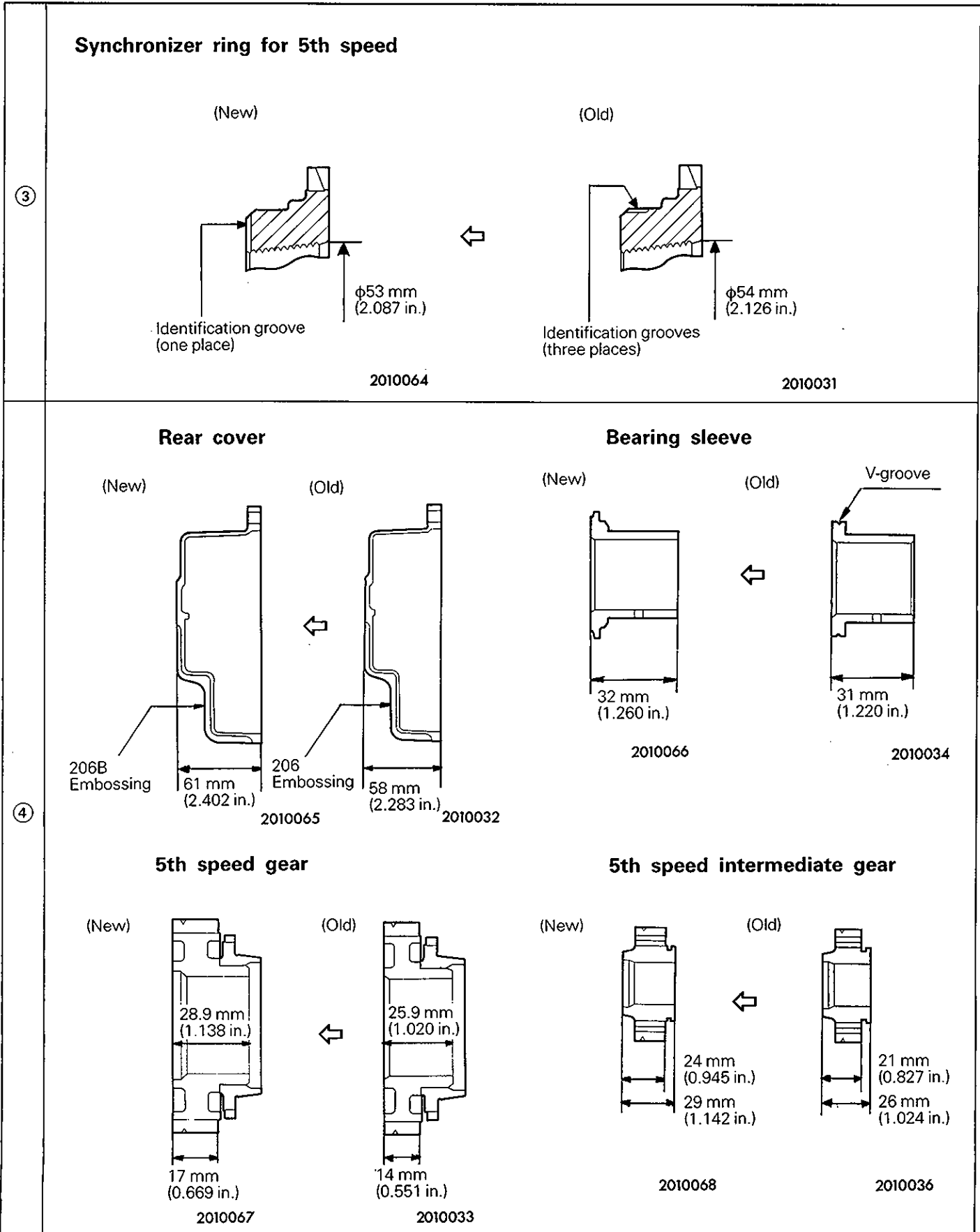

Snap ring

⑤

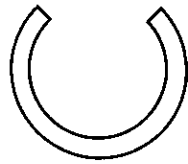

2010075

Rear cover

(New)

Embossing
F5M2 ... F5M21, F5M22
F5M31 ... F5M31

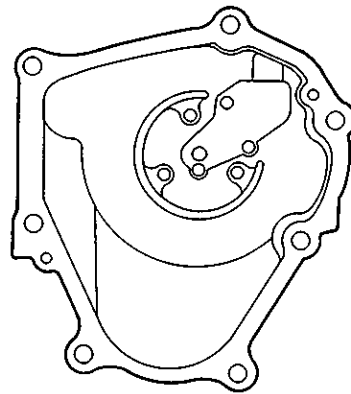
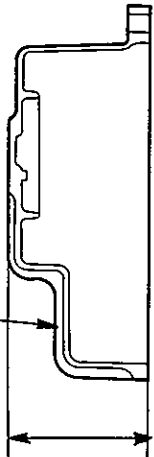

62.6 mm (2.465 in.) ... F5M21, F5M22
60.6 mm (2.386 in.) ... F5M31

2010078

⑥

(Old)

Embossing
206B ... F5M21, F5M22
210 ... F5M31

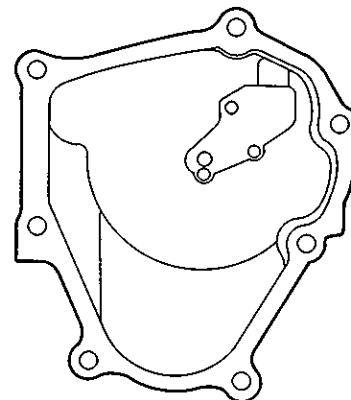
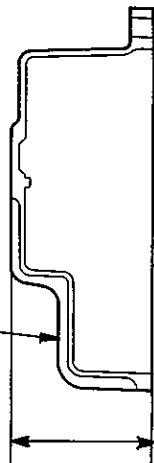

61 mm (2.402 in.) ... F5M21, F5M22
59 mm (2.323 in.) ... F5M31

2010038

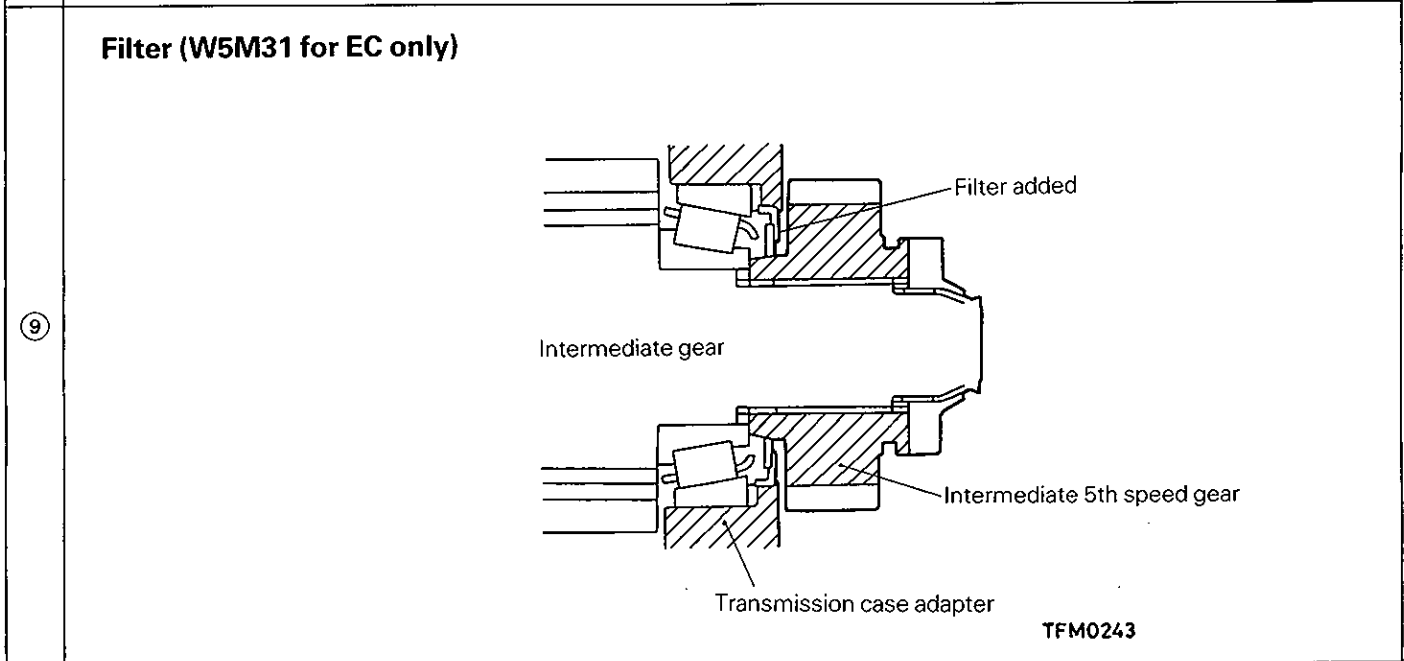
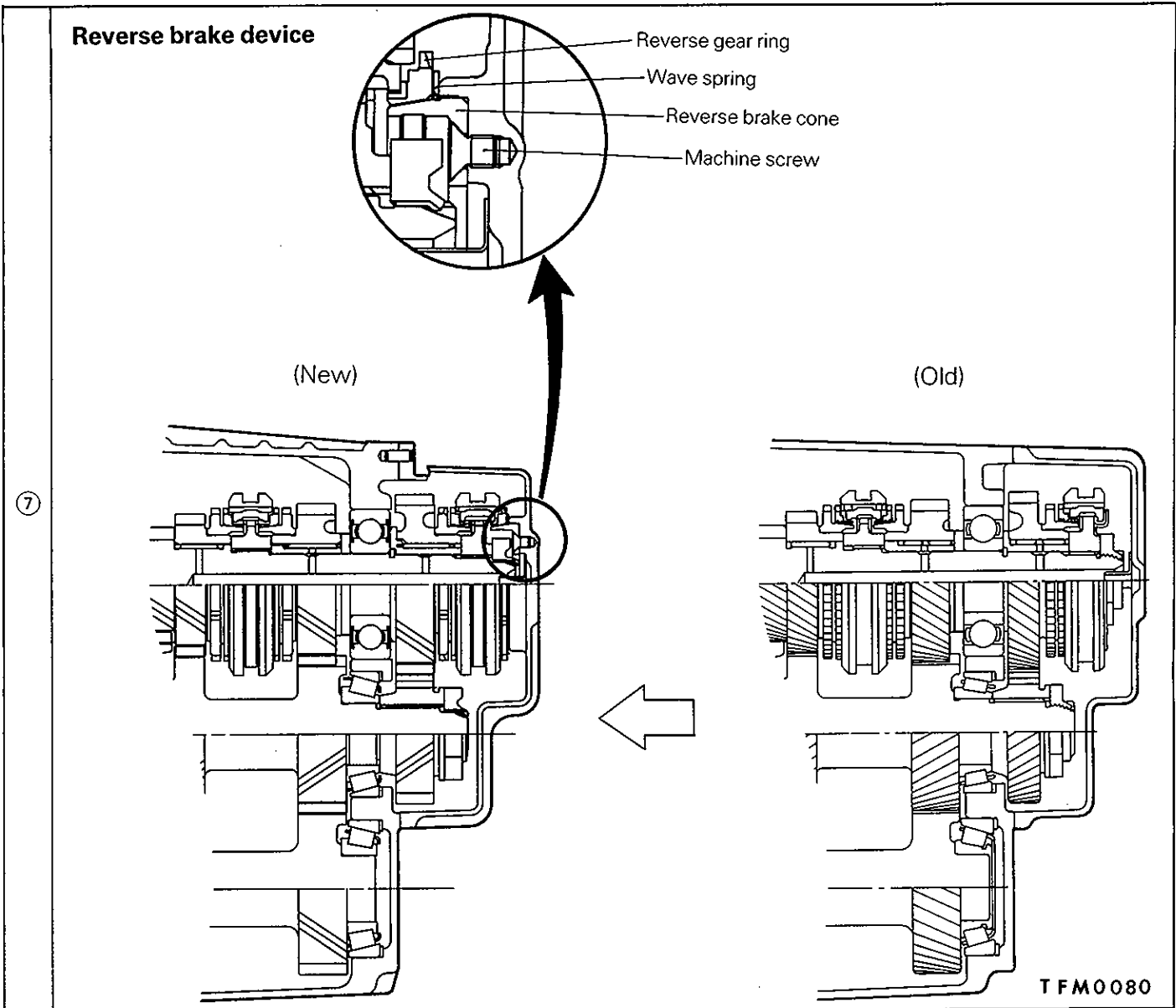

SERVICE POINTS OF DISASSEMBLY

Ⓐ REMOVAL OF SPRING PIN FOR OD-R SHIFT FORK

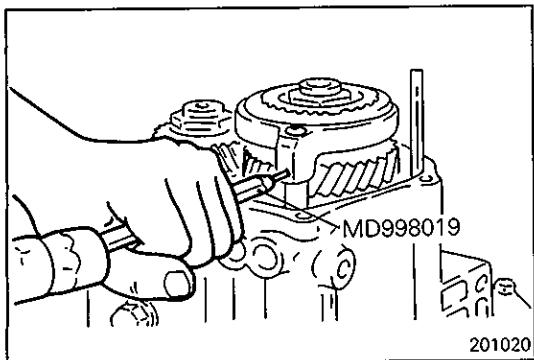

Ⓑ REMOVAL OF LOCK NUTS FOR INPUT SHAFT / INTERMEDIATE GEAR

(1) Unstake lock nuts of the input shaft and intermediate gear.

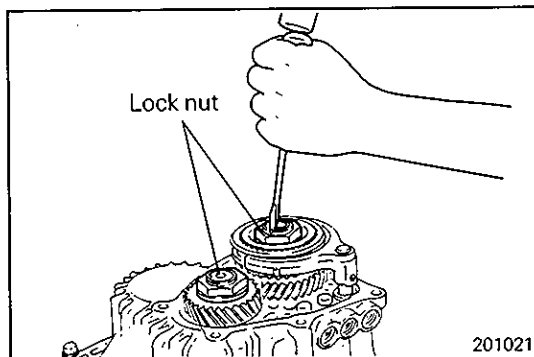

(2) Shift the transmission in reverse using the control lever and select lever.

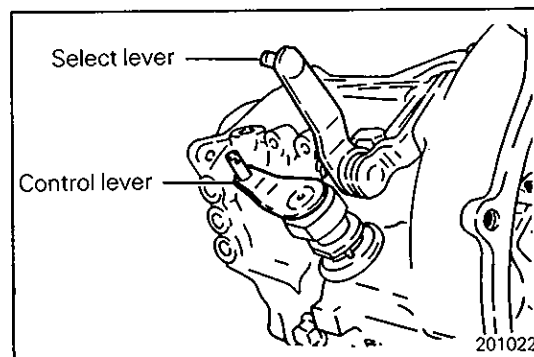

- (3) Install the special tool onto the input shaft.
- (4) Screw a bolt (10 mm) into the bolt hole on the periphery of clutch housing and attach a spinner handle to the special tool.
- (5) Remove the lock nut, while using the bolt as a spinner handle stopper.

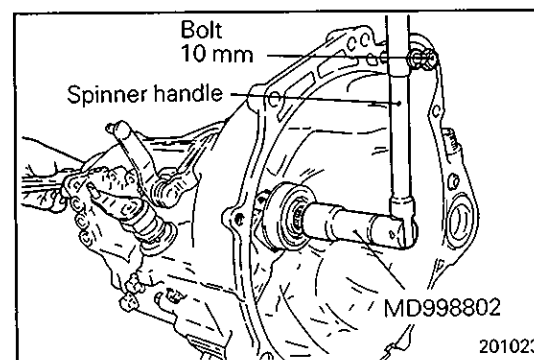

Ⓒ REMOVAL OF SPRING PINS FOR 1ST-2ND SPEED SHIFT FORK / 3RD-4TH SPEED SHIFT FORK

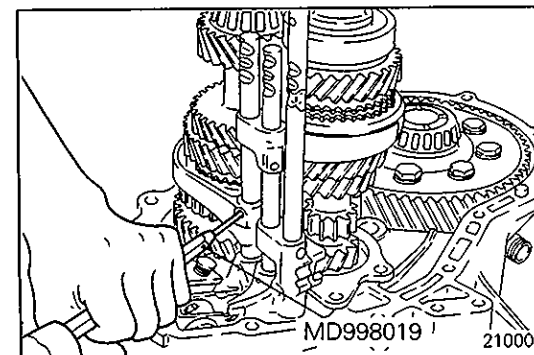

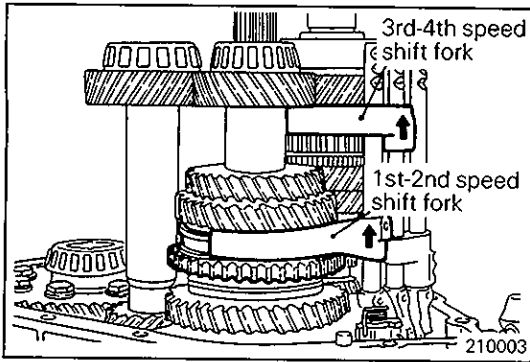

ⓓ REMOVAL OF SHIFT RAIL ASSEMBLY

- (1) Shift the 1st-2nd speed shift fork to the 2nd speed.
- (2) Shift the 3rd-4th speed shift fork to the 4th speed.

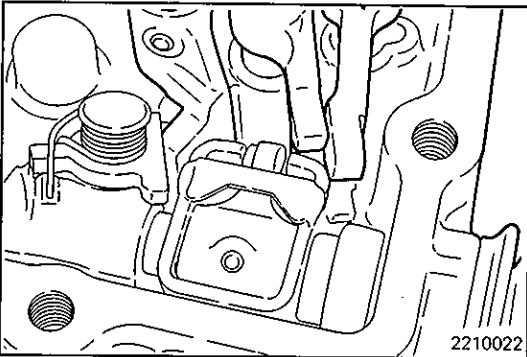

- (3) Remove the shift rail assembly as shown in the illustration so as not to hit the interlock plate and control finger.

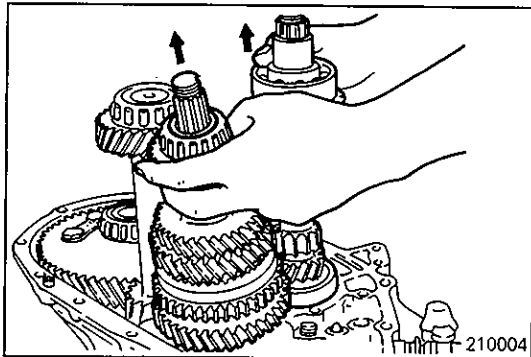

ⓔ REMOVAL OF INTERMEDIATE GEAR ASSEMBLY / INPUT SHAFT ASSEMBLY

- (1) Lift up the input shaft assembly and remove the intermediate gear assembly.

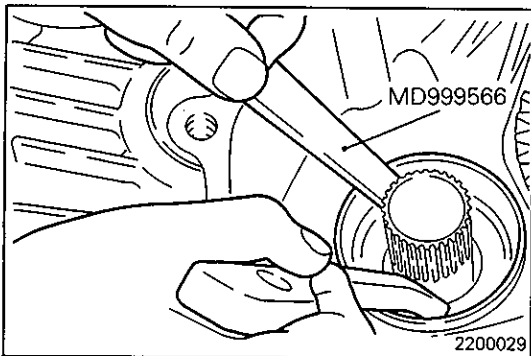

ⓕ REMOVAL OF BEARING OUTER RACE

SERVICE POINTS OF REASSEMBLY

ⓐ INSTALLATION OF OIL SEAL FOR DRIVE SHAFT

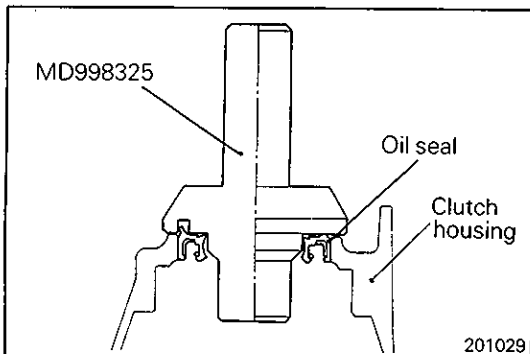

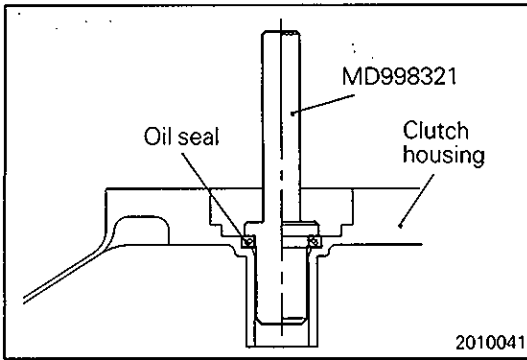

B INSTALLATION OF OIL SEAL FOR INPUT SHAFT FRONT

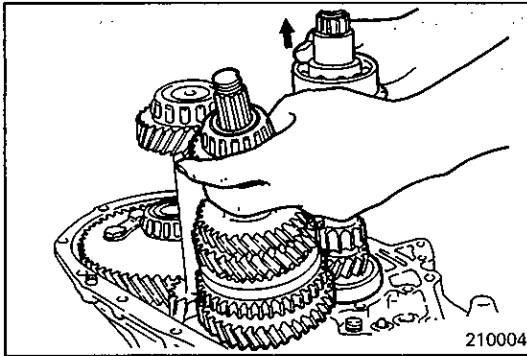

C INSTALLATION OF INTERMEDIATE GEAR ASSEMBLY / INPUT SHAFT ASSEMBLY

- (1) Lifting up the input shaft assembly, install it simultaneously with the intermediate gear assembly.

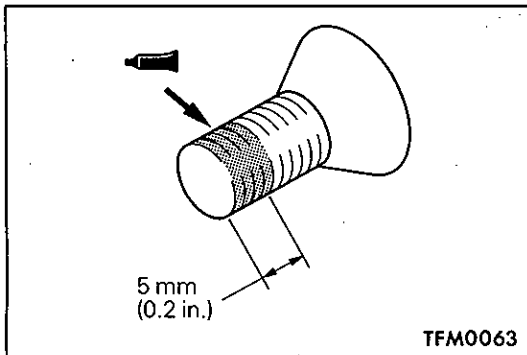

D APPLICATION OF SEALANT TO BEARING RETAINER MOUNTING BOLT

Specified sealant: 3M STUD Locking No. 4170 or equivalent

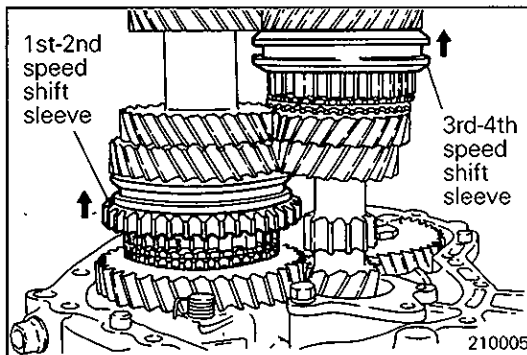

E INSTALLATION OF SHIFT RAIL ASSEMBLY

- (1) Set the 1st-2nd speed shift sleeve at 2nd speed.
- (2) Set the 3rd-4th speed shift sleeve at 4th speed.
- (3) Install the shift forks to respective sleeves.

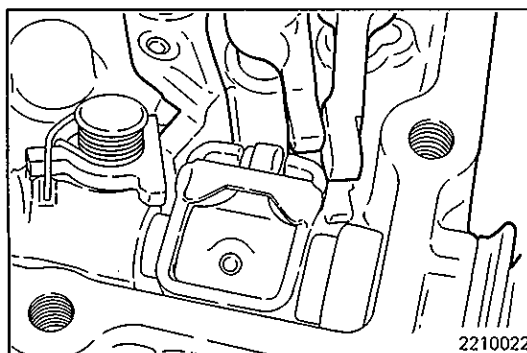

- (4) Insert the shift rail into the shift fork hole, while turning so as to prevent the shift lug from interfering with the stopper plate.
- (5) Turn the shift rail to engage shift lug.

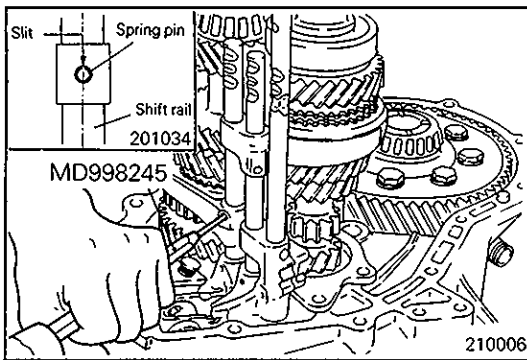

F INSTALLATION OF SPRING PINS FOR 1ST-2ND SPEED SHIFT FORK / 3RD-4TH SPEED SHIFT FORK

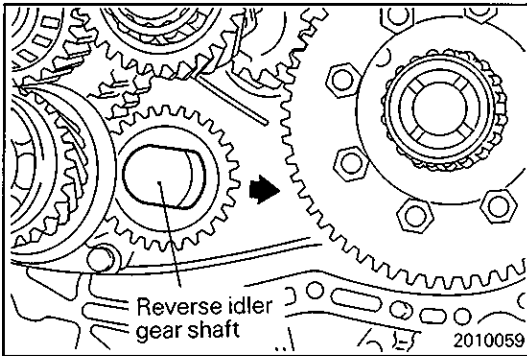

G INSTALLATION OF REVERSE IDLER GEAR SHAFT

- (1) Install in the direction as illustrated.

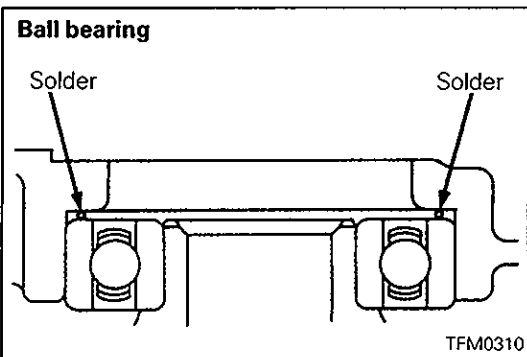

H SPACERS SELECTION

- (1) Place solder with a length of approximately 10 mm (0.39 in.) and a diameter of approximately 1.6 mm (0.063 in.) in the spacer mounting position.
- (2) Tighten the case mounting bolt at the specified torque.
- (3) Remove the case and then take out the solder. If the solder is not broken, use solder with a larger diameter to carry out the operations in (1) and (2).

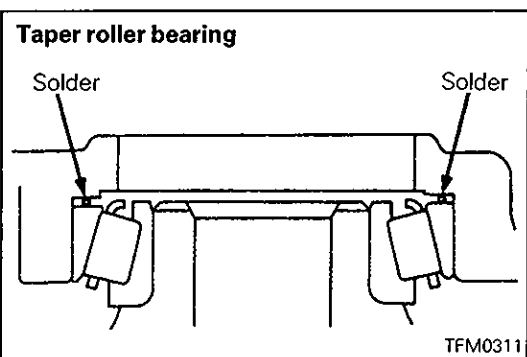

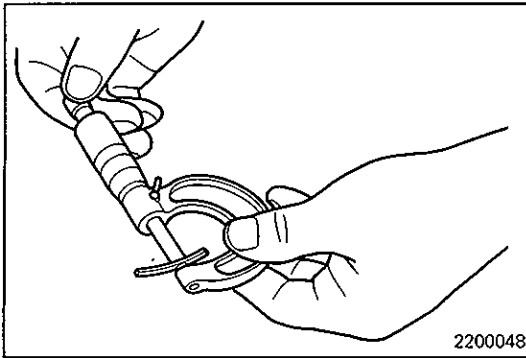

- (4) Measure the thickness of the crushed solder with a micrometer and select and install a spacer of thickness that gives standard end play and preload.

Standard value:

Input shaft preload

0 – 0.05 mm (0 – 0.002 in.) F5M33

Intermediate gear

0.05 – 0.17 mm (0.002 – 0.007 in.) F4M21, F5M21

0.05 – 0.10 mm (0.002 – 0.004 in.)
F5M22, F5M31, F5M33

Output shaft

0.05 – 0.17 mm (0.002 – 0.007 in.)
F4M21, F5M21 (Up to JUN. 1987)

0.05 – 0.10 mm (0.002 – 0.004 in.)
F4M21, F5M21 (From JUL. 1987)
F5M22, F5M31, F5M33

Differential case

0.05 – 0.17 mm (0.002 – 0.007 in.) F4M21, F5M21

0.05 – 0.10 mm (0.002 – 0.004 in.)
F5M22, F5M31, F5M33

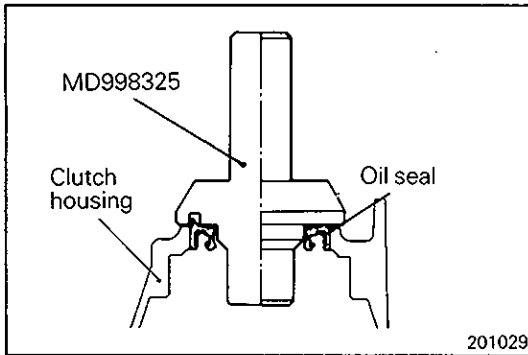

I INSTALLATION OF OIL SEAL FOR DRIVE SHAFT

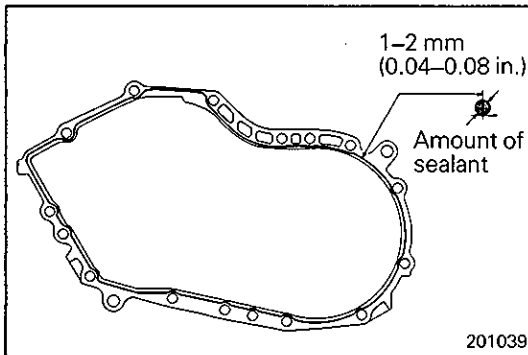

J APPLICATION OF SEALANT TO TRANSMISSION CASE

- (1) Squeeze out sealant from the tube uniformly without excess or discontinuity.

Specified sealant: Mitsubishi genuine sealant Part No. MD997740 or equivalent

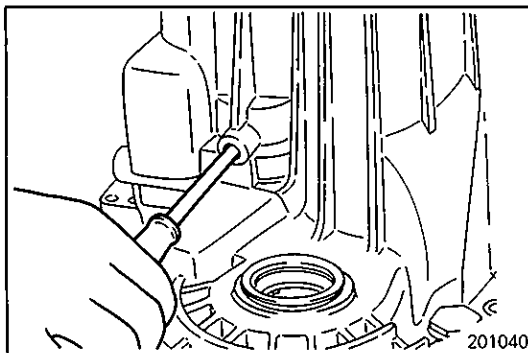

K INSTALLATION OF REVERSE IDLER GEAR SHAFT BOLT

- (1) Center the shaft with a Phillips screwdriver [shaft diameter 8 mm (0.32 in.)] or the like.
- (2) Tighten the reverse idler gear shaft bolt to specified torque.

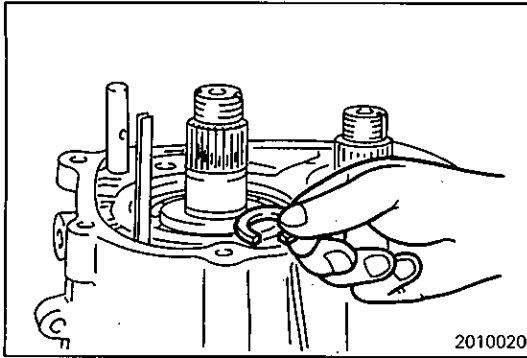
**L INSTALLATION OF SNAP RING**

- (1) Select the thickest snap ring that can be fitted into the snap ring groove.

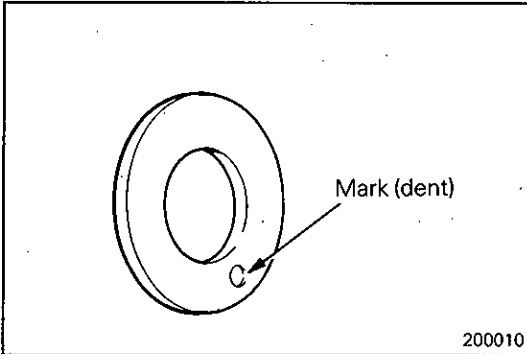
**M INSTALLATION OF DISHED WASHER**

- (1) Install the dished washer with the face identified by mark (dent) toward lock nut.

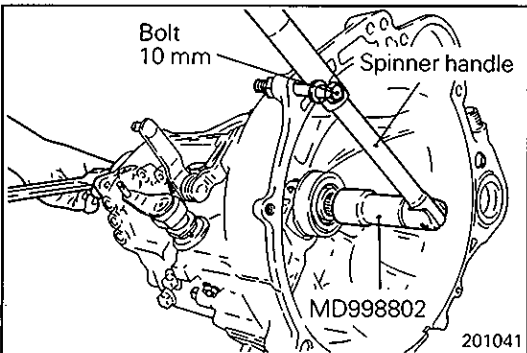
**N INSTALLATION OF LOCK NUTS FOR INPUT SHAFT / INTERMEDIATE GEAR**

- (1) Install the special tool onto the input shaft.
- (2) Screw a bolt (10 mm) into the hole on the periphery of clutch housing and attach a spinner handle to the special tool.

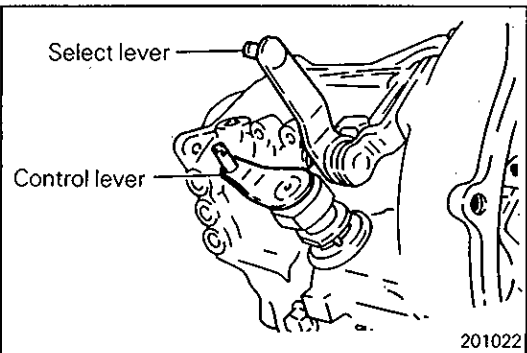

- (3) Shift the transmission in reverse using control lever and select lever.

- (4) Tighten the lock nut to specified torque, while using the bolt attached in the above step as a spinner handle stopper.

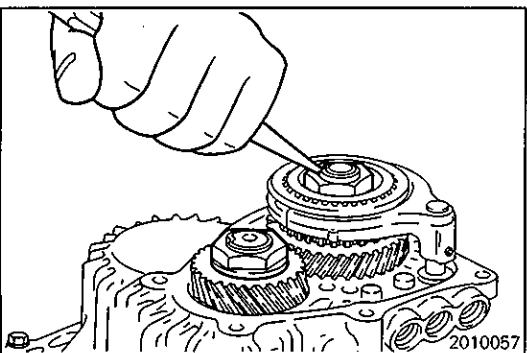

- (5) Stake the lock nut.

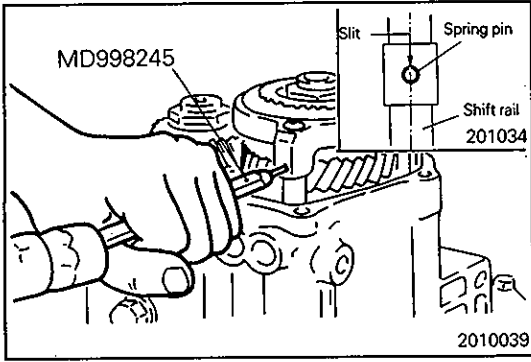

Q INSTALLATION OF SPRING PIN FOR OD-R SHIFT FORK

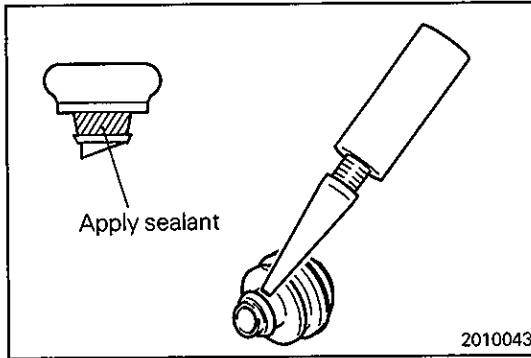

P APPLICATION OF SEALANT TO AIR BREATHER
Specified sealant: 3M SUPER WEATHERSTRIP No. 8001 or equivalent

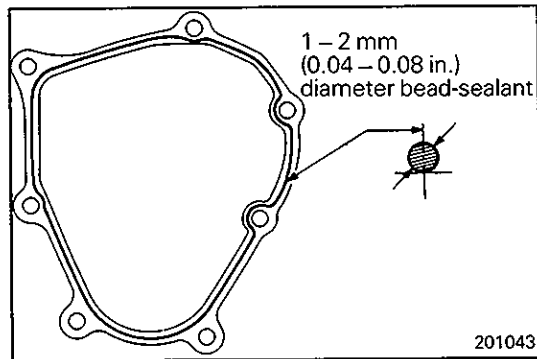

Q APPLICATION OF SEALANT TO REAR COVER
Specified sealant: Mitsubishi genuine sealant Part No. MD997740 or equivalent

Caution

- Squeeze out sealant from the tube uniformly without excess or discontinuity.

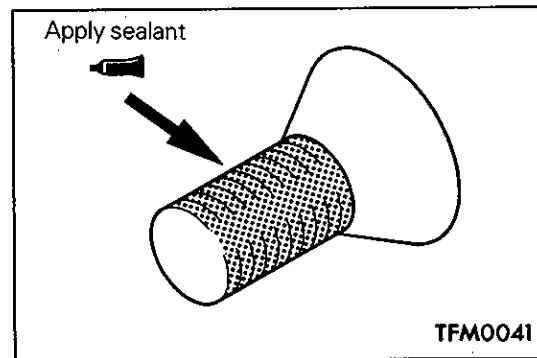

R APPLICATION OF SEALANT TO MACHINE SCREW
Specified sealant: 3M STUD Locking No. 4170 or equivalent

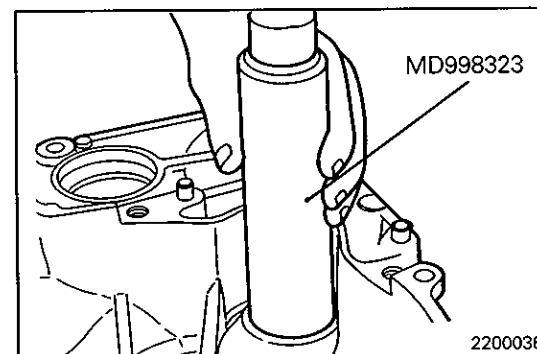

S INSTALLATION OF OIL SEAL

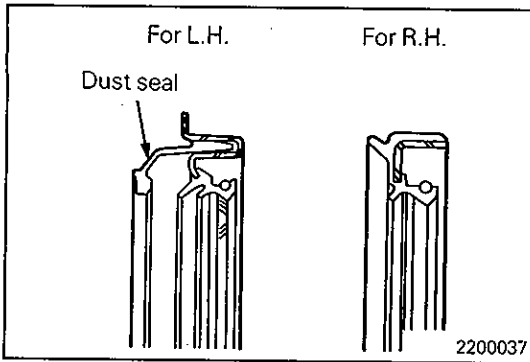

T INSTALLATION OF OIL SEAL

- (1) Install the drive shaft oil seals, the correct ones on correct sides, using the special tool.

Caution

- Install in such position that the notch of the L.H. oil seal flange faces up as installed on vehicle.

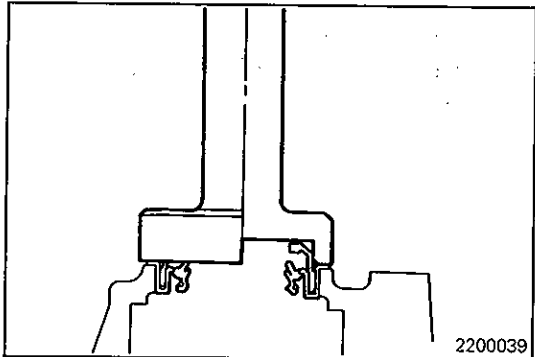

U INSTALLATION OF SPACERS

- (1) Place two pieces of solder measuring about 10 mm (0.39 in.) in length and 3 mm (0.12 in.) in diameter at illustrated locations on the transmission and install each outer race.

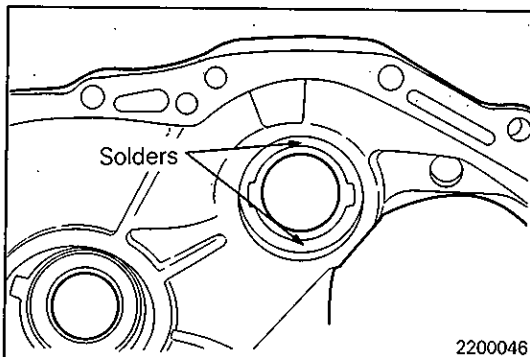

- (2) Place two pieces of solder measuring about 10 mm (0.39 in.) in length and 3 mm (0.12 in.) in diameter on the bearing outer race as shown in illustration.
- (3) Install the transmission case and tighten the bolts to specified torque.
- (4) Remove the transmission case and remove the solder.

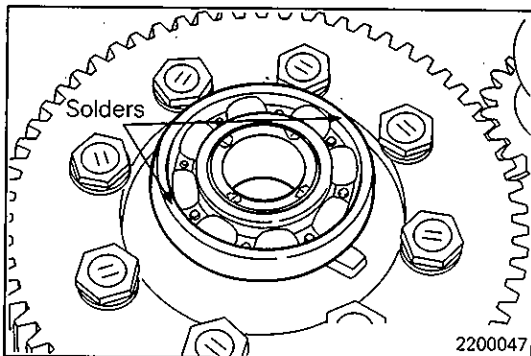

- (5) Measure the thickness of the crushed solder with a micrometer and select and install a spacer of thickness that gives standard end play.

Standard value:

Front output shaft bearing preload:
0.08 – 0.13 mm (0.0031 – 0.0051 in.)

Front differential case end play:
0.05 – 0.17 mm (0.0020 – 0.0067 in.)

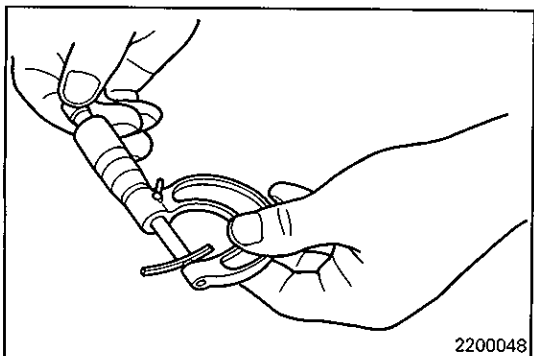

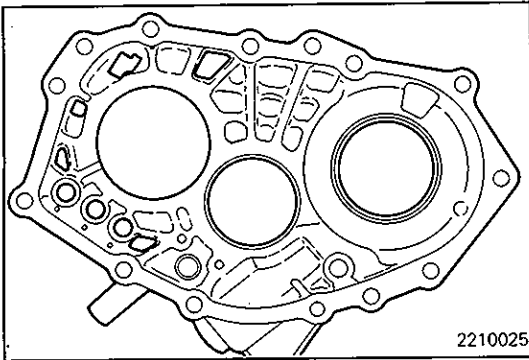

V INSTALLATION OF SPACERS

- (1) Place two pieces of solder measuring about 10 mm (0.39 in.) in length and 3 mm (0.12 in.) in diameter at illustrated locations on the transmission case adapter assembly and install each outer race.
- (2) Install the transmission case adapter assembly and rear cover and tighten the bolts to specified torque.
- (3) Remove the transmission case adapter assembly and rear cover.

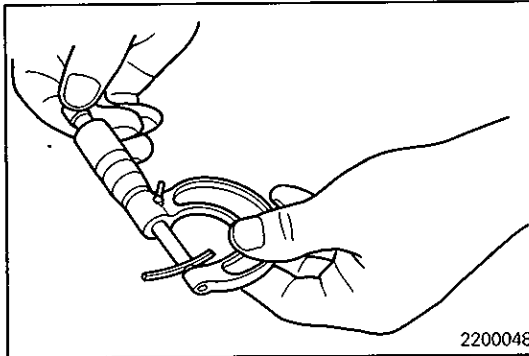

- (4) Remove each outer race and remove the solder. Measure the thickness of the crushed solder with a micrometer and select and install a spacer of thickness that gives standard end play and preload.

Standard value:

Intermediate gear preload:

0.08 – 0.13 mm (0.0031 – 0.0051 in.)

Center differential case preload:

0.08 – 0.13 mm (0.0031 – 0.0051 in.)

Input shaft end play:

0 – 0.05 mm (0 – 0.0020 in.) W5M33

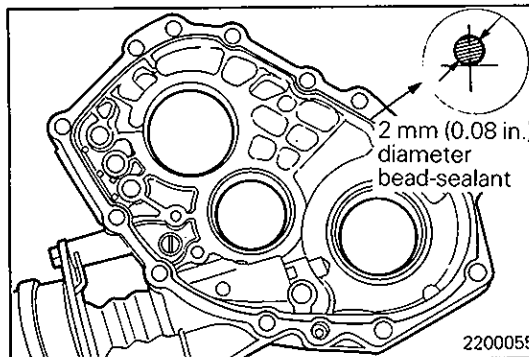

W INSTALLATION OF TRANSMISSION CASE ADAPTER ASSEMBLY

- (1) Apply specified sealant (liquid gasket) to the transmission case side of the transmission case adapter assembly.

Specified sealant: Mitsubishi genuine sealant Part No. MD997740 or equivalent

Caution

- Squeeze out sealant from the tube uniformly without excess or discontinuity.

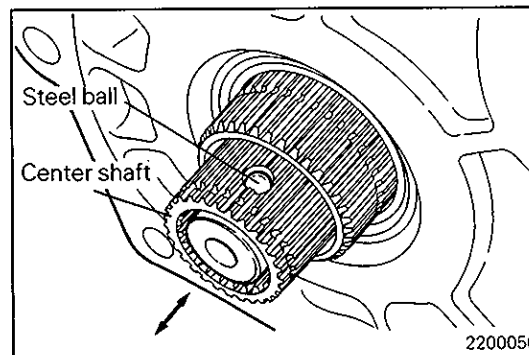

X INSTALLATION OF STEEL BALLS

- (1) Move the center shaft so that the steel balls are securely seated in the grooves.

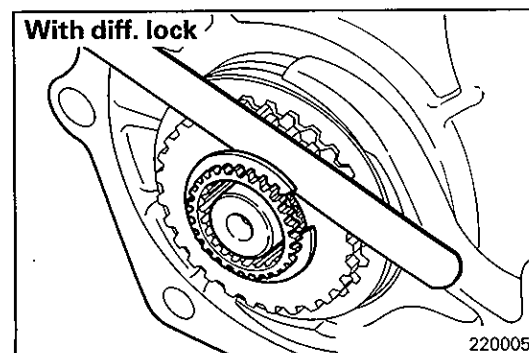

Y INSTALLATION OF SNAP RING

- (1) Choose a snap ring that gives the standard end play of the clutch gear and install it.

Standard value:

Clutch gear: 0.10 – 0.26 mm (0.0039 – 0.0102 in.)

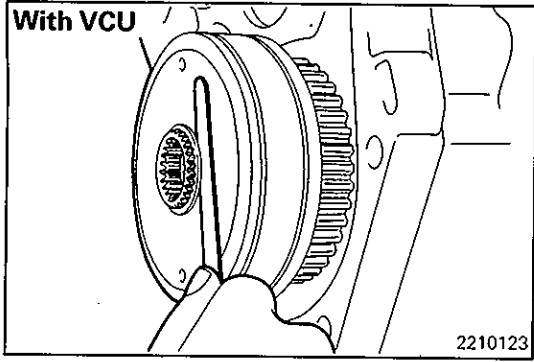

4. 5TH SPEED SYNCHRONIZER <5-speed Model Only>

DISASSEMBLY AND REASSEMBLY

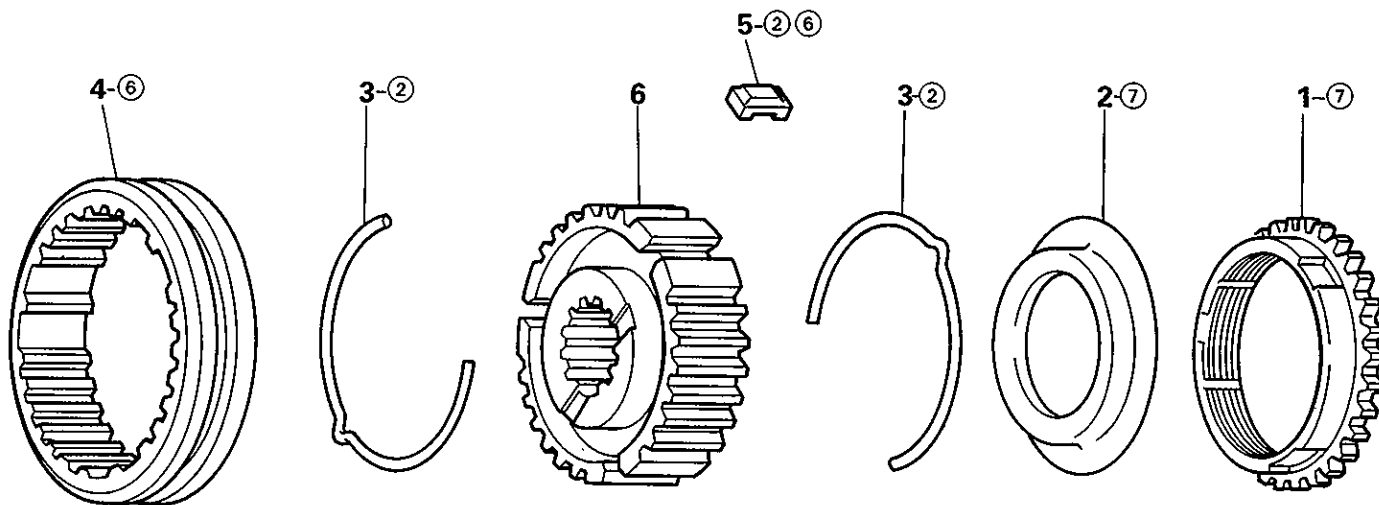

Disassembly steps

1. Reverse brake ring
2. Stop plate
3. Synchronizer spring
4. Synchronizer sleeve
5. Synchronizer key
6. Synchronizer hub

NOTE

②⑥⑦: Refer to "Details of Change" table.

TFM0055

Details of Change

Synchronizer spring

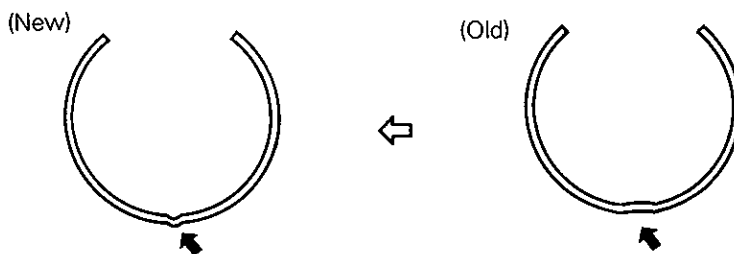

②

Synchronizer key

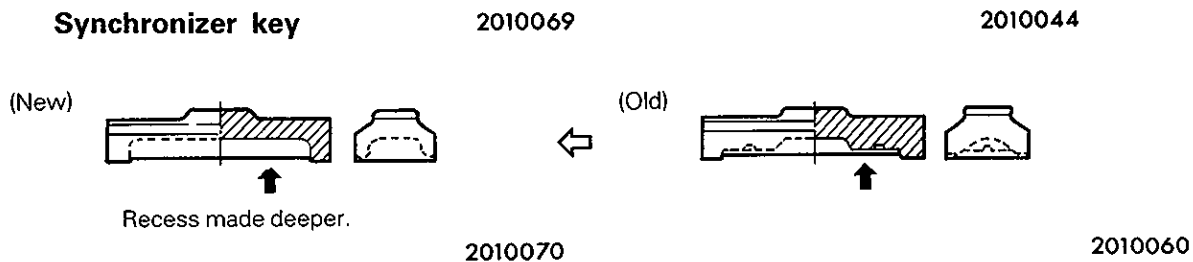

Synchronizer sleeve

(New)

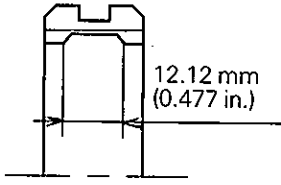

(Old)

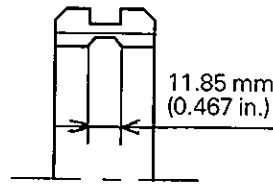

⑥

Synchronizer key

2010071

2010061

(New)

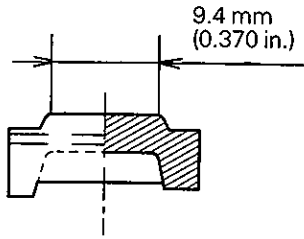

(Old)

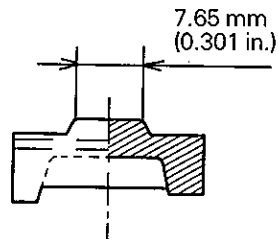

2010072

2010062

Reverse brake ring

Stop plate

(New)

(Old)

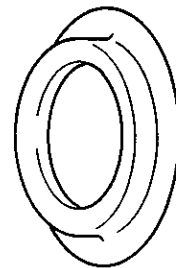
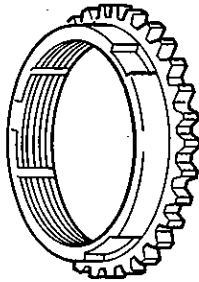

⑦

TFM0081

TFM0082

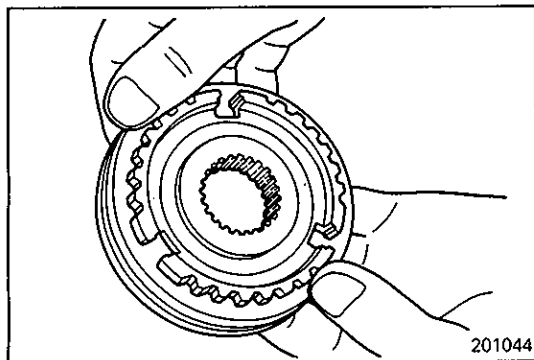

INSPECTION

SYNCHRONIZER SLEEVE AND HUB

- (1) Combine the synchronizer sleeve and hub and check that they slide smoothly.
- (2) Check that the sleeve is free from damage at its inside front and rear ends.
- (3) Check for wear of the hub front end (surface in contact with the 5th speed gear).

Caution

- When replacing, replace the synchronizer hub and sleeve as a set.

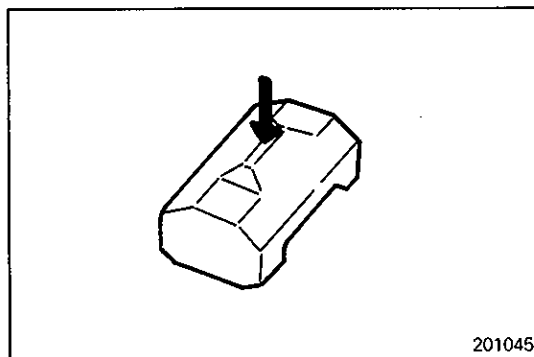

SYNCHRONIZER KEY AND SPRING

- (1) Check for wear of the synchronizer key center protrusion.
- (2) Check the spring for weakness, deformation and breakage.

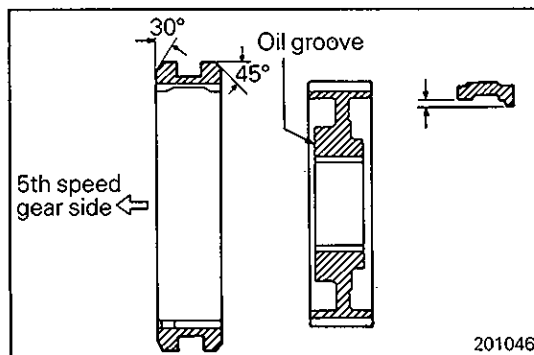

SERVICE POINTS OF REASSEMBLY

A INSTALLATION OF SYNCHRONIZER HUB / SYNCHRONIZER KEY / SYNCHRONIZER SLEEVE

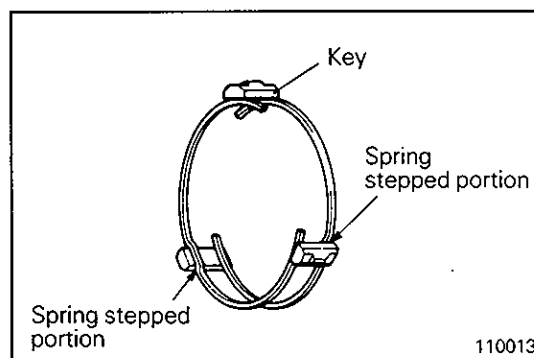

B INSTALLATION OF SYNCHRONIZER SPRING

- (1) When installing the synchronizer springs, be sure to position each spring with respect to the keys as illustrated.

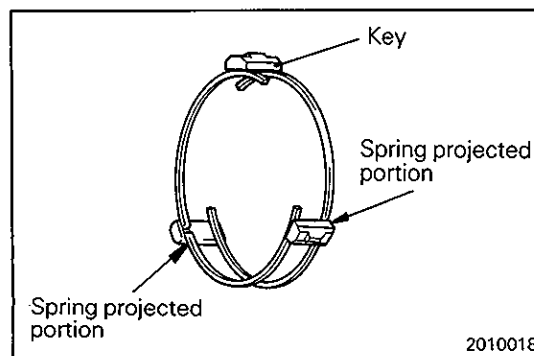

NOTES

5. INPUT SHAFT

F4M21, F5M21

DISASSEMBLY AND REASSEMBLY

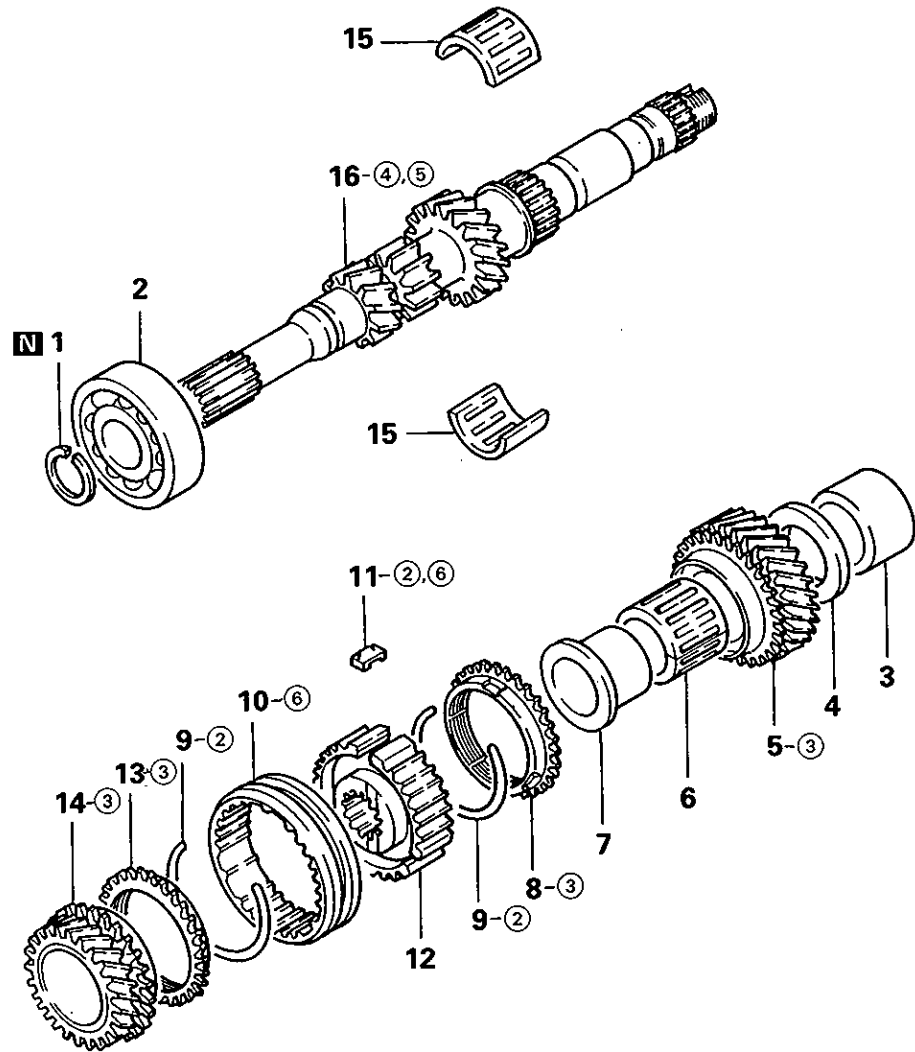

Disassembly steps

- (A) (K) 1. Snap ring
- (A) (J) 2. Ball bearing
- (A) (F) 3. Inner ring
- (A) (E) 4. Spacer
- (C) 5. 4th speed gear
- (C) 6. Needle bearing
- (C) 7. Bearing sleeve
- (C) 8. Synchronizer ring
- (B) 9. Synchronizer spring
- (A) 10. 3rd-4th speed synchronizer sleeve
- (B) 11. Synchronizer key
- (A) 12. 3rd-4th speed synchronizer hub

- (C) 13. Synchronizer ring
- (C) 14. 3rd speed gear
- (C) 15. Needle bearing
- (C) 16. Input shaft

NOTE

(2)(3)(4)(5)(6): Refer to "Details of Change" table.

F5M22, F5M31 W5M31

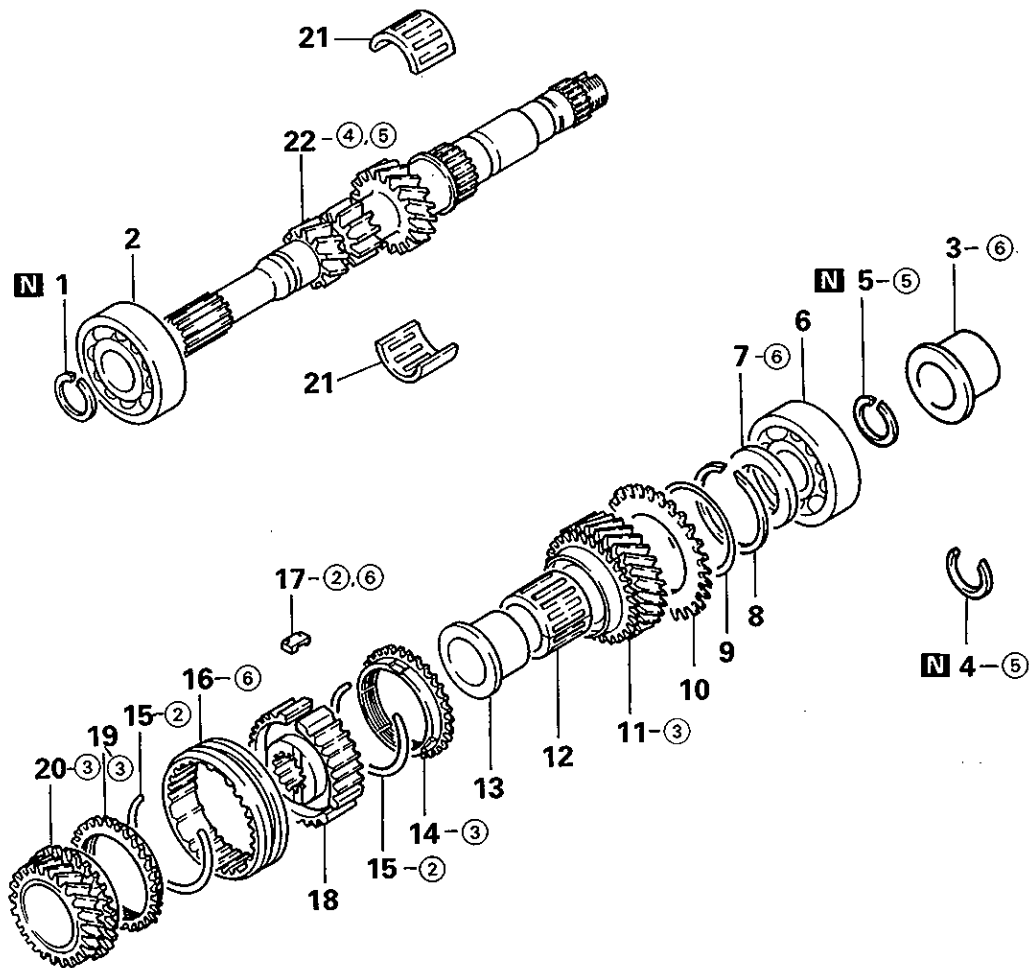

Disassembly steps

- K** 1. Snap ring
- A** **J** 2. Ball bearing
- B** 3. Bearing sleeve
- H** 4. Snap ring (From DEC. 1987 – F5M22)
- H** 5. Snap ring (From DEC. 1987 – F5M31)
- D** **G** 6. Ball bearing
- D** 7. Spacer
- D** 8. Snap ring (KM206-0-EKPH, F5M31)
- D** 9. Cone spring (KM206-0-EKPH, F5M31)
- D** 10. Subgear (KM206-0-EKPH, F5M31)
- 11. 4th speed gear
- C** 12. Needle bearing
- C** 13. Bearing sleeve

- B** 14. Synchronizer ring
- A** 15. Synchronizer spring
- B** 16. 3rd-4th speed synchronizer sleeve
- A** 17. Synchronizer key
- A** 18. 3rd-4th speed synchronizer hub
- D** 19. Synchronizer ring
- D** 20. 3rd speed gear
- D** 21. Needle bearing
- D** 22. Input shaft

NOTE

②③④⑤⑥: Refer to "Details of Change" table.

F5M33, W5M33

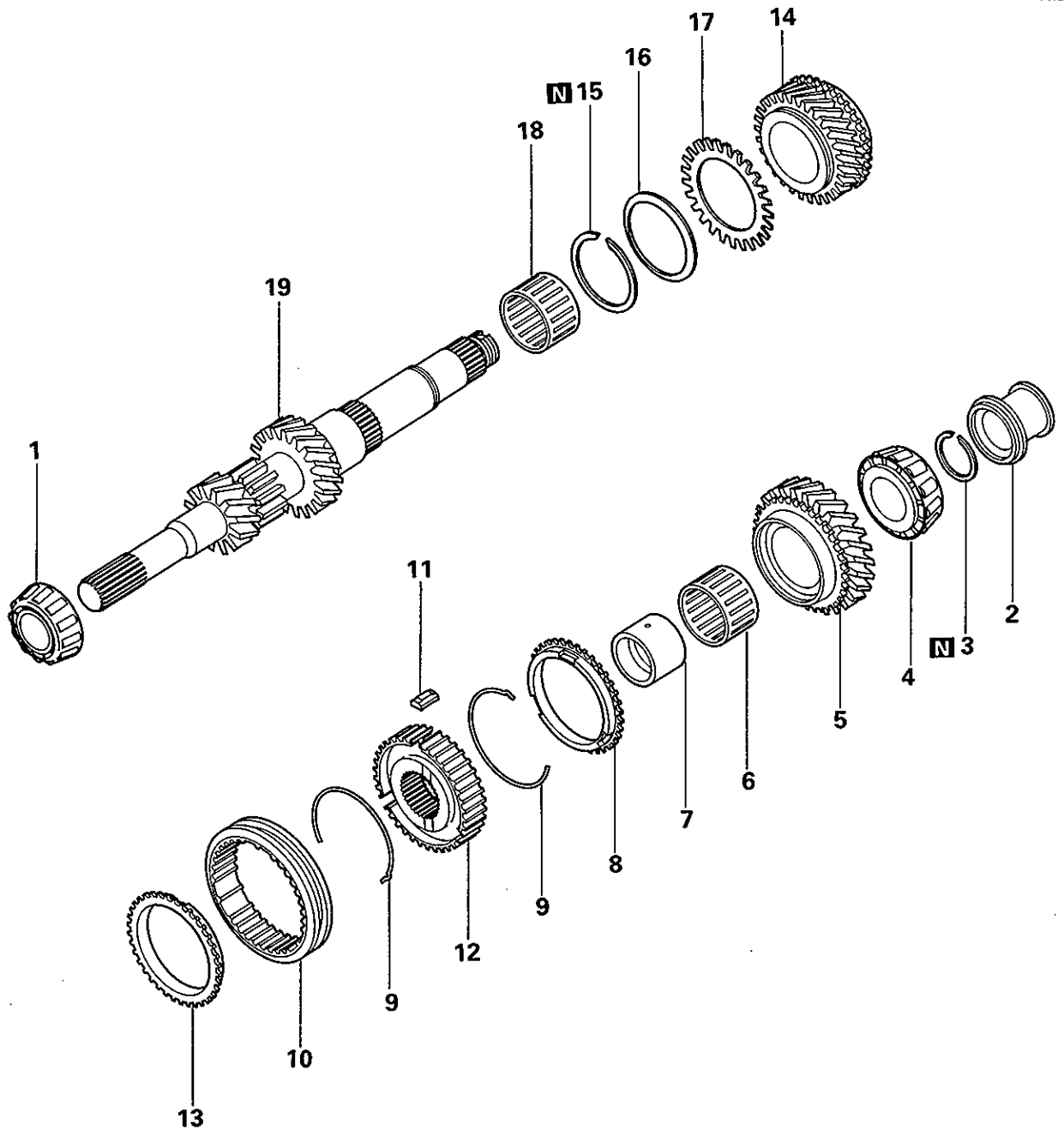

Disassembly steps

- (A) (K) 1. Taper roller bearing
- (B) (J) 2. Bearing sleeve
- (I) 3. Snap ring
- (D) (G) 4. Taper roller bearing
- 5. 4th speed gear
- (C) 6. Needle bearing
- 7. Bearing sleeve
- 8. Synchronizer ring
- (B) 9. Synchronizer spring

- (A) 10. 3rd-4th speed synchronizer sleeve
- (B) 11. Synchronizer key
- (A) 12. 3rd-4th speed synchronizer hub
- 13. Synchronizer ring
- (D) 14. 3rd speed gear
- (D) 15. Snap ring
- (D) 16. Cone spring
- (D) 17. Sub gear
- 18. Needle bearing
- 19. Input shaft

Intentionally blank

Details of Change

②

Synchronizer spring for 3rd-4th speed

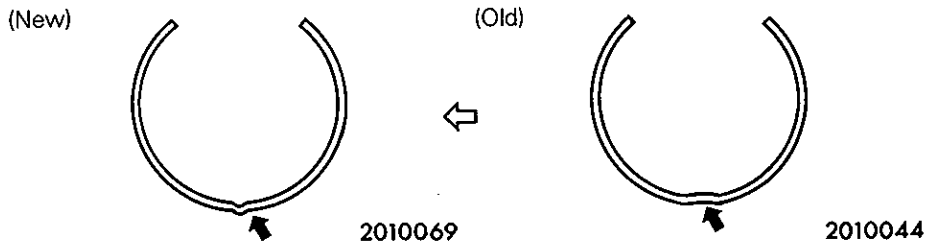

Synchronizer key for 3rd-4th speed

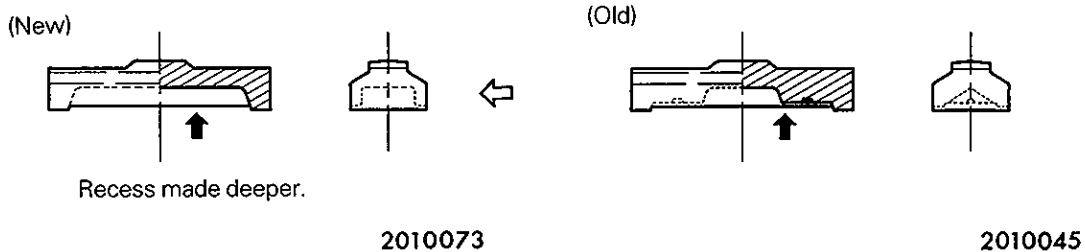

③

Synchronizer ring for 3rd-4th speed
(F4M21, F5M21, F5M22)

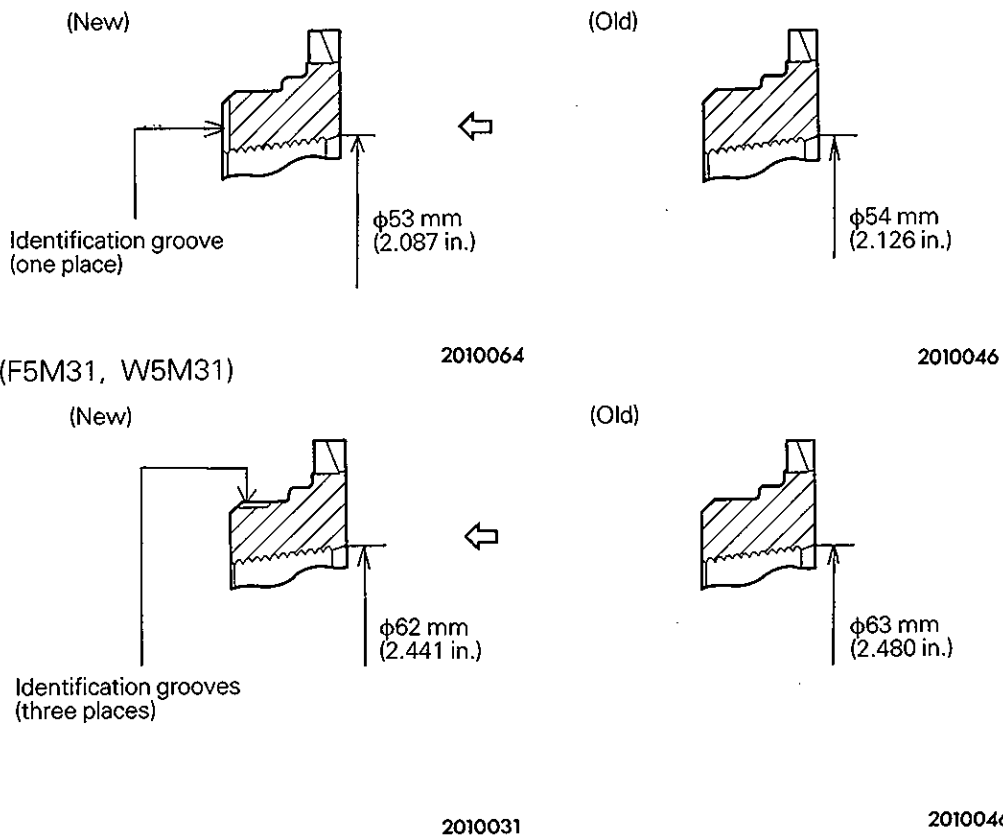

③

3rd speed gear

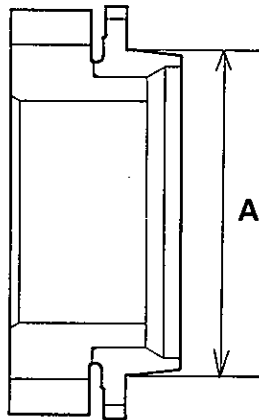

TFM0083

(F4M21, F5M21, F5M22)
 (New) (Old)
 A = 53 mm ← 54 mm
 (F5M31, W5M31)
 (New) (Old)
 A = 62 mm ← 63 mm

4th speed gear

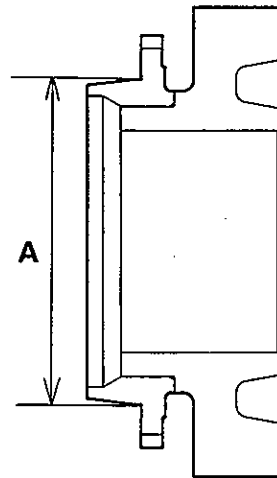

TFM0084

(F4M21, F5M21, F5M22)
 (New) (Old)
 A = 53 mm ← 54 mm
 (F5M31, W5M31)
 (New) (Old)
 A = 53 mm ← 54 mm

④

Input shaft

(New)

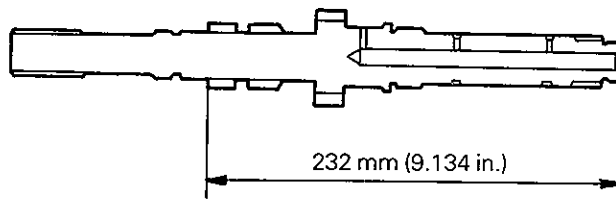

2010048

(Old)

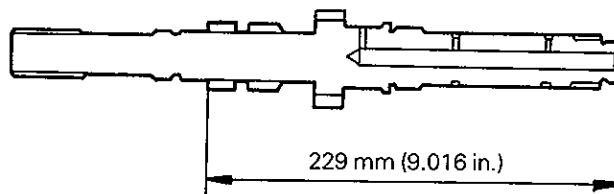

2010048

5

Input shaft

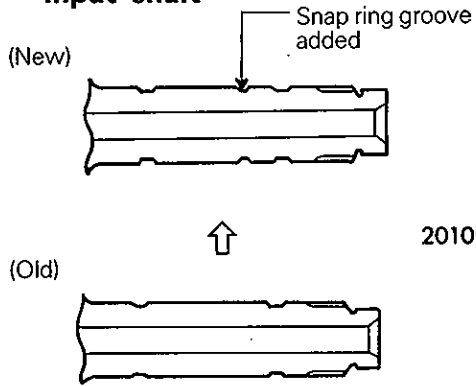

2010074

2010049

Snap ring (F5M22)

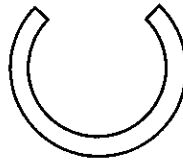

2010075

(F5M31, W5M31)

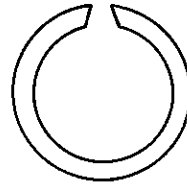

2010050

Bearing sleeve

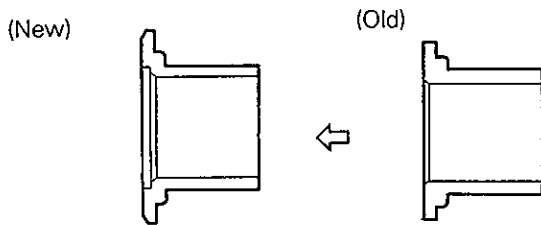

2060024

2060026

Spacer (F5M31, W5M31)

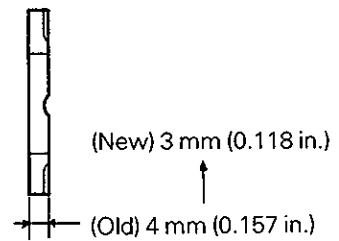

2100035

6

Synchronizer sleeve



2010071

2010061

Synchronizer key

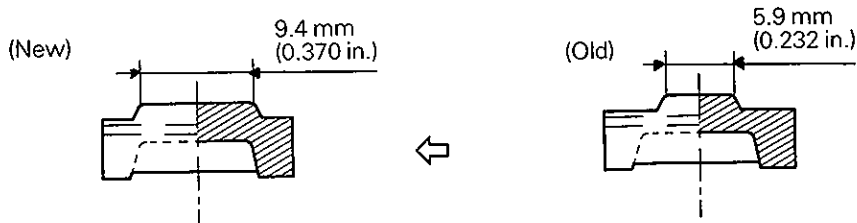

2010076

2010063

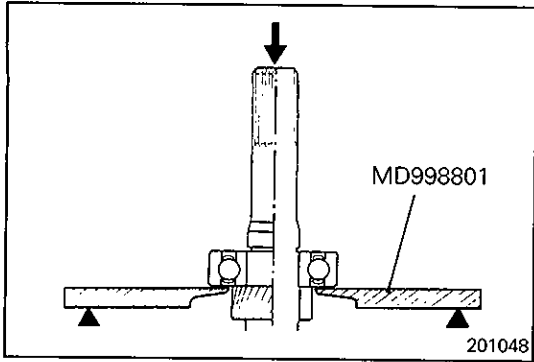

SERVICE POINTS OF REASSEMBLY

Ⓐ REMOVAL OF FRONT BALL BEARING / FRONT TAPER ROLLER BEARING

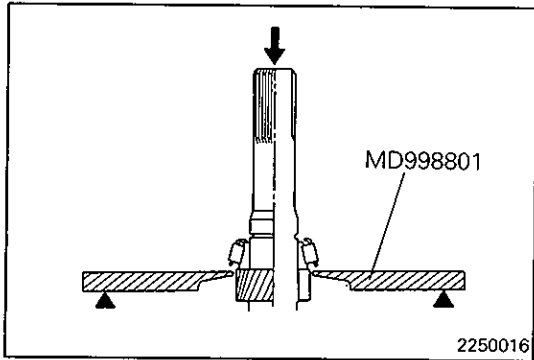

Ⓑ REMOVAL OF BEARING SLEEVE FOR 5TH SPEED GEAR

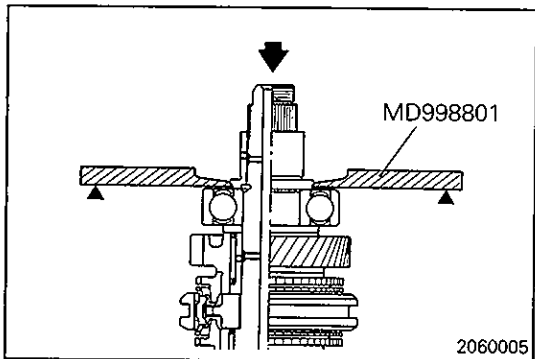

Ⓒ REMOVAL OF 4TH SPEED GEAR / 3RD SPEED GEAR

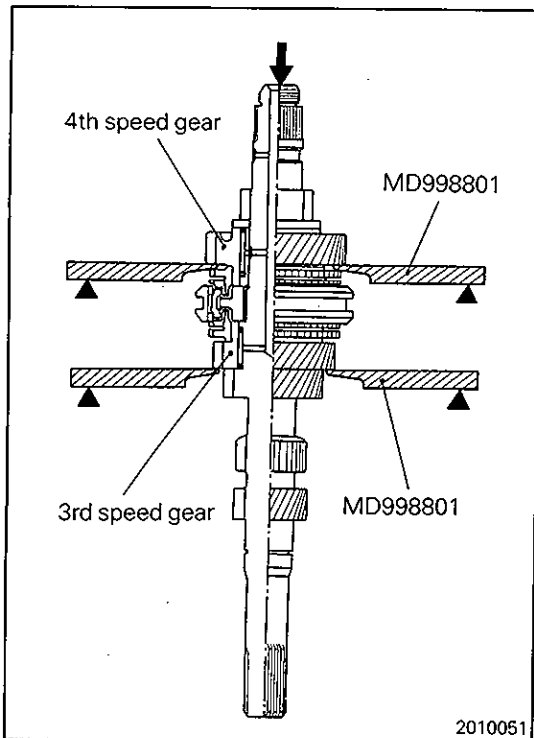

ⓐ REMOVAL OF REAR BALL BEARING TAPER ROLLER BEARING / 3RD SPEED GEAR

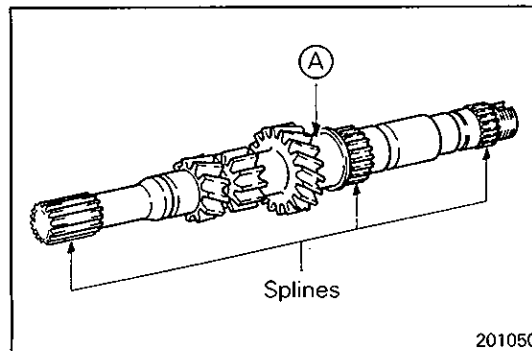
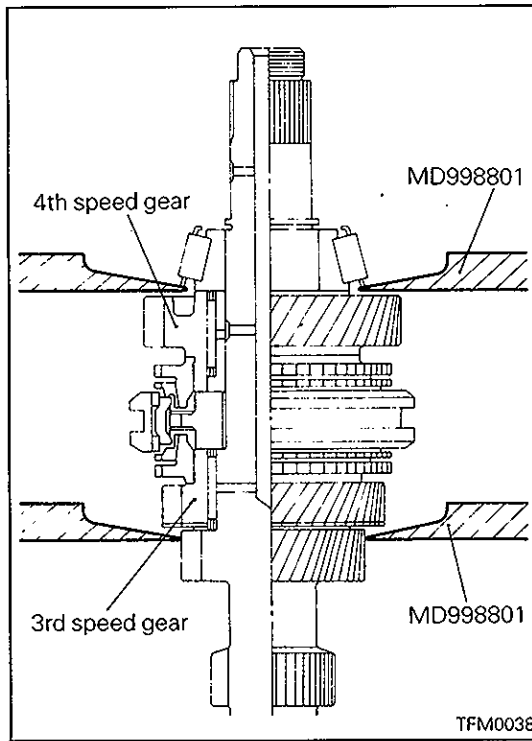
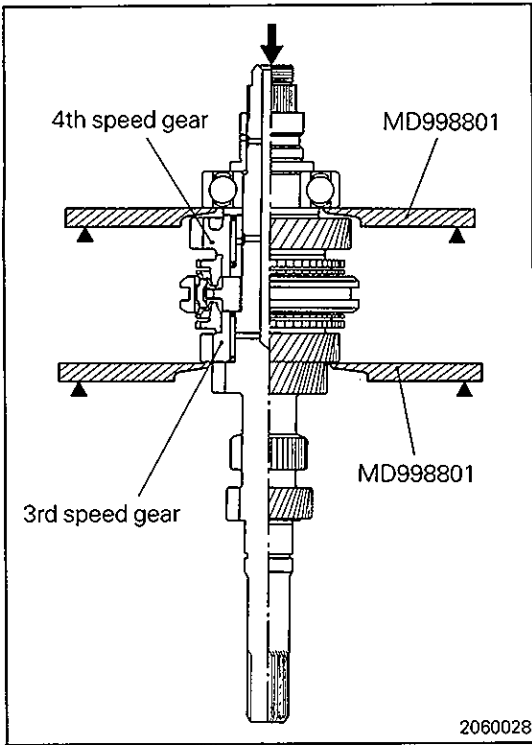

**INSPECTION
INPUT SHAFT**

- (1) Check the outer surface of the input shaft where the needle bearing is mounted for damage, abnormal wear and seizure [portion A].
- (2) Check the splines for damage and wear.

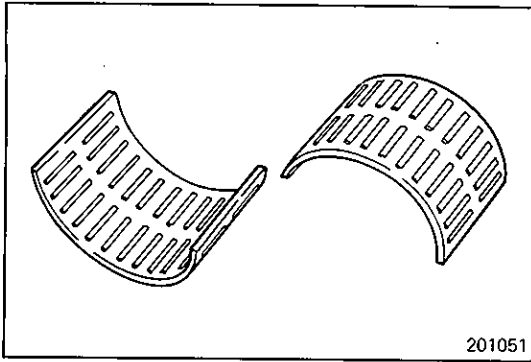

201051

NEEDLE BEARING

- (1) Combine the needle bearing with the shaft or bearing sleeve and gear and check that it rotates smoothly without abnormal noise or play.
- (2) Check the needle bearing cage for deformation.

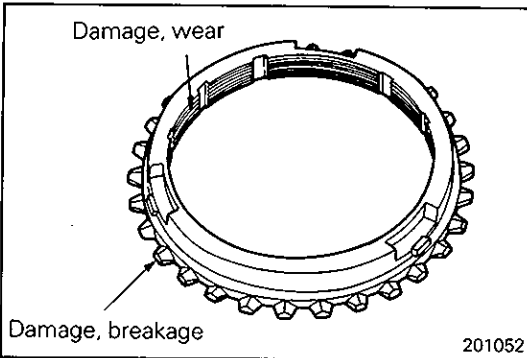

201052

SYNCHRONIZER RING

- (1) Check the clutch gear teeth for damage and breakage.
- (2) Check the internal surface for damage, wear and broken threads.

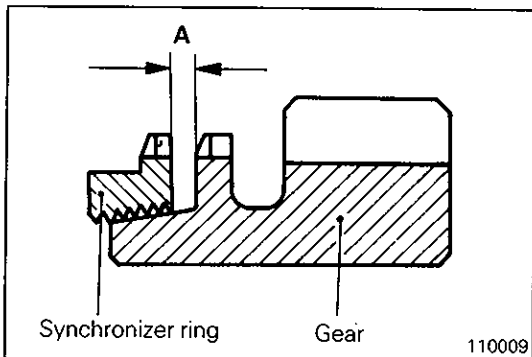

110009

- (3) Force the synchronizer ring toward the clutch gear and check clearance "A". Replace if it is out of specification.

Limit: 0.5 mm (0.02 in.)

SYNCHRONIZER SLEEVE AND HUB

- (1) Combine the synchronizer sleeve and hub and check that they slide smoothly.
- (2) Check that the sleeve is free from damage at its inside front and rear ends.
- (3) Check for wear of the hub end surfaces (in contact with each speed gear).

Caution

- When replacing, replace the synchronizer hub and sleeve as a set.

SYNCHRONIZER KEY AND SPRING

- (1) Check for wear of the synchronizer key center protrusion.
- (2) Check the spring for weakness, deformation and breakage.

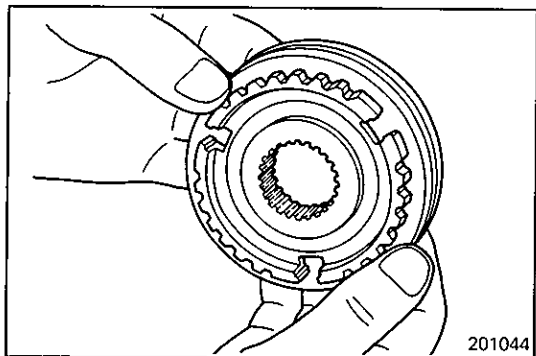

201044

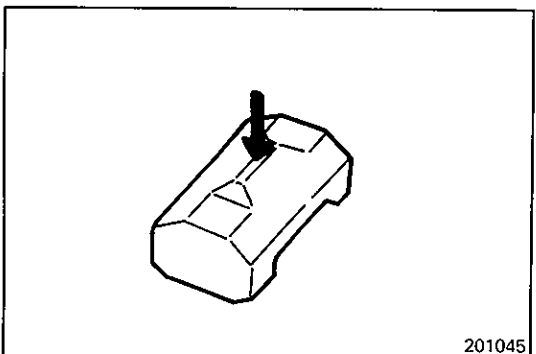

201045

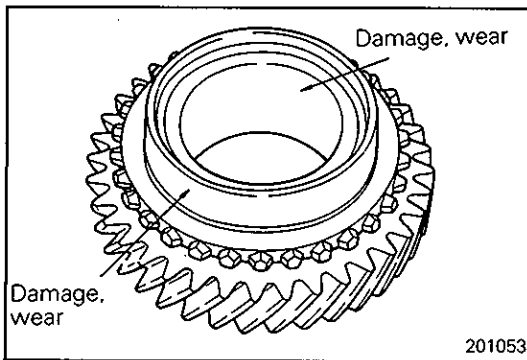

SPEED GEARS

- (1) Check the synchronizer cone for rough surface, damage and wear.
- (2) Check the gear bore and front and rear ends for damage and wear.

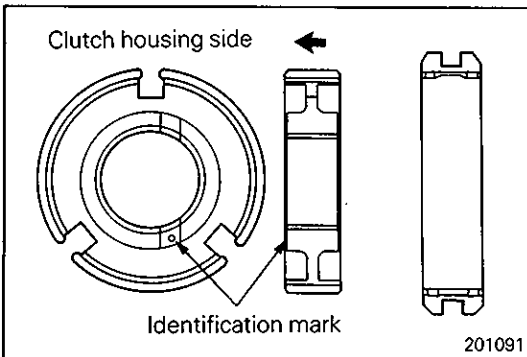

SERVICE POINTS OF REASSEMBLY

A INSTALLATION OF 3RD-4TH SPEED SYNCHRONIZER HUB / 3RD-4TH SPEED SYNCHRONIZER SLEEVE

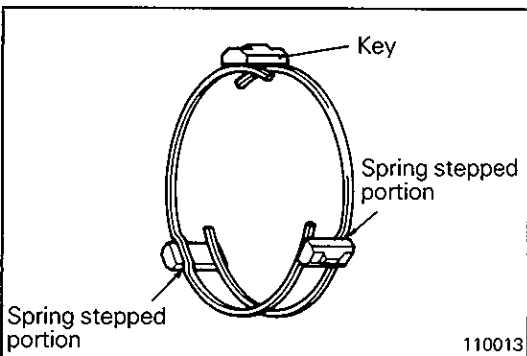

B INSTALLATION OF SYNCHRONIZER SPRING / SYNCHRONIZER KEY

- (1) When installing the synchronizer springs, be sure to position each spring with respect to the keys as illustrated.

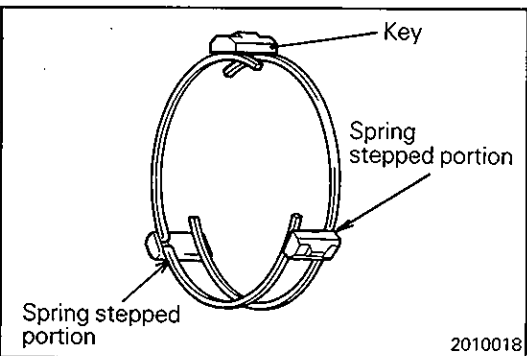

C INSTALLATION OF BEARING SLEEVE FOR 4TH SPEED GEAR

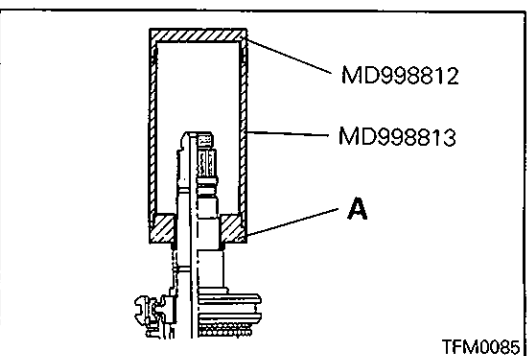

	F5M21, F5M22	F5M31, F5M33, W5M31, W5M33
A	MD998817	MD998818

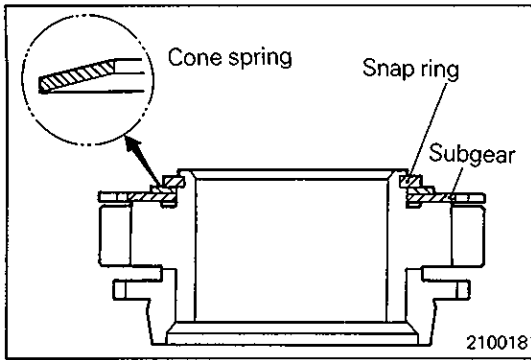

D INSTALLATION OF SUB GEAR / CONE SPRING / SNAP RING

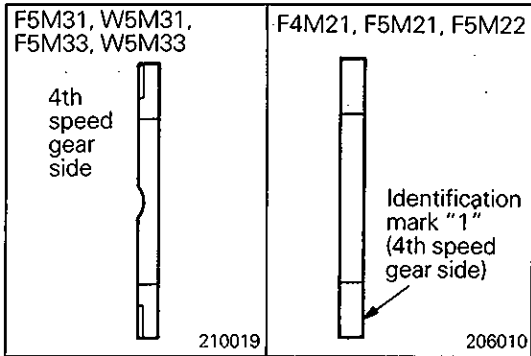

E INSTALLATION OF SPACER

- (1) Install with the side having the identification mark "1" on the 4th speed gear side. Spacers without identification mark may be installed in either direction.

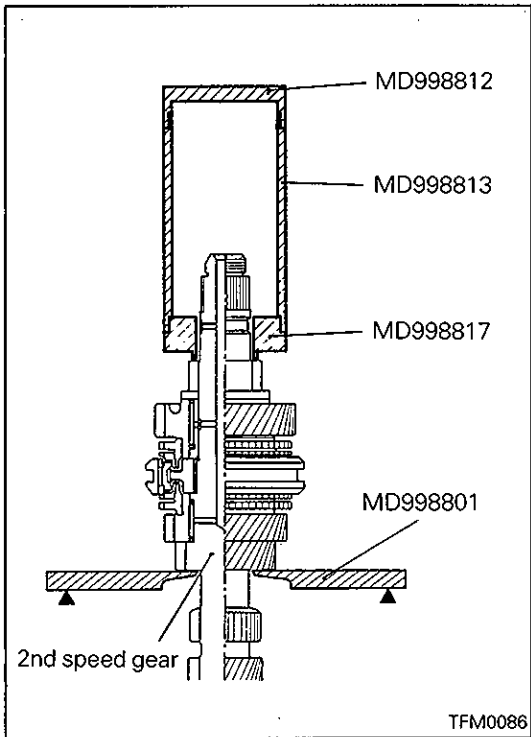

F INSTALLATION OF INNER RING FOR REAR BEARING

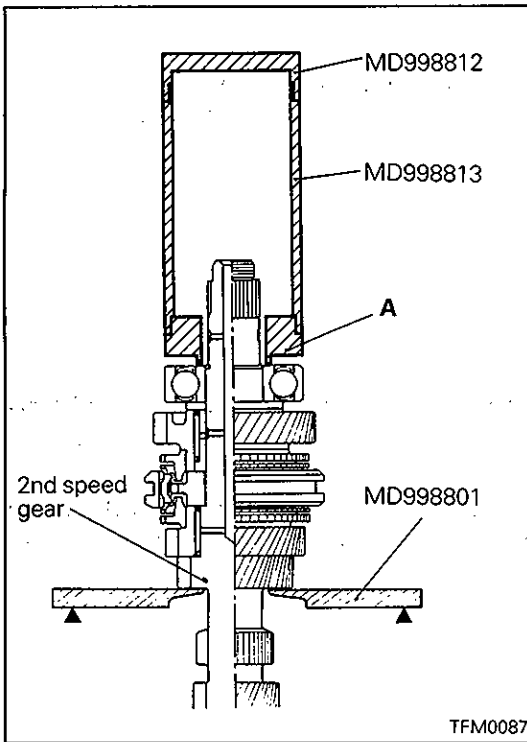

G INSTALLATION OF REAR BALL BEARING

	F5M22	F5M31, F5M33, W5M31, W5M33
A	MD998817	MD998818

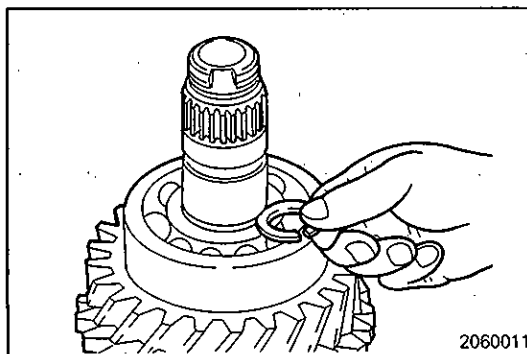
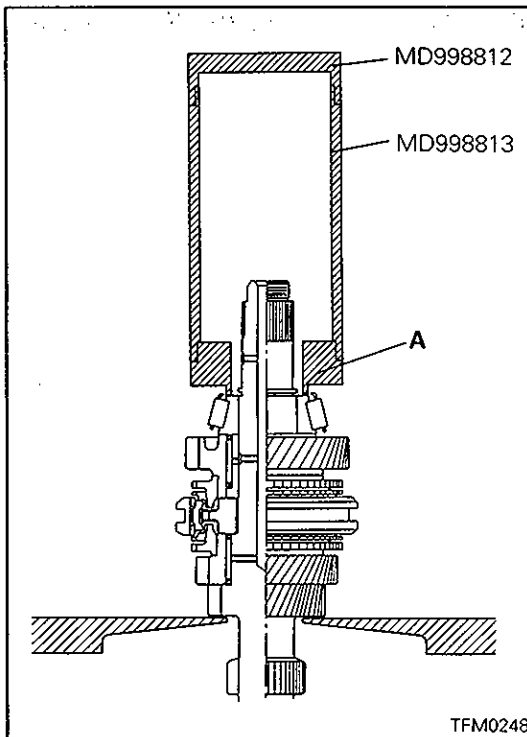

H INSTALLATION OF SNAP RING

- (1) Select the thickest snap ring that can be fitted in the snap ring groove.

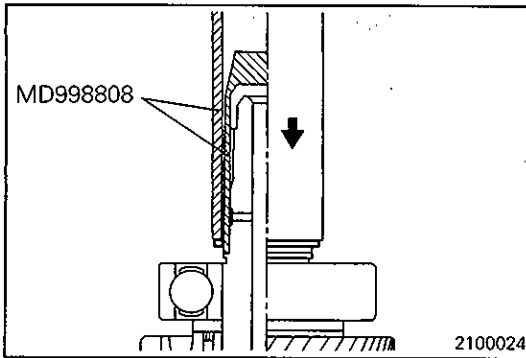
**Caution**

- Do not reuse the snap ring.
- The snap ring may be opened too wide by pliers, resulting in improper installation of the sleeve.

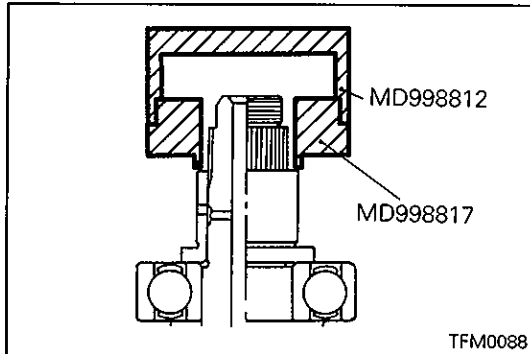
**I INSTALLATION OF BEARING SLEEVE FOR 5TH SPEED GEAR****Caution**

- When press-fitting the sleeve to the input shaft, make sure that the sleeve flange is closely fitted to the bearing.

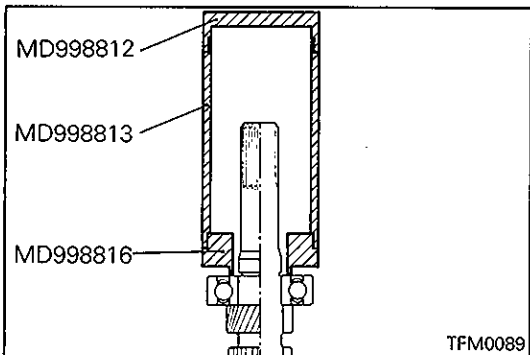
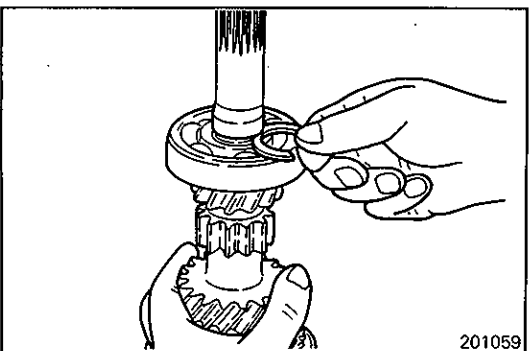
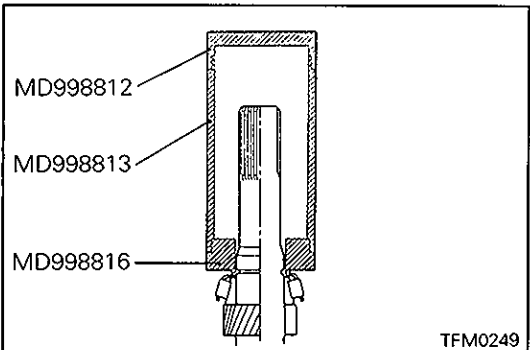
**J INSTALLATION OF FRONT BALL BEARING / FRONT TAPER ROLLER BEARING****K INSTALLATION OF SNAP RING**

- (1) Snap rings are available in three different thickness. Select the thickest one that fits in the snap ring groove.

Caution

- Do not damage the input shaft oil seal contacting portion.

6. INTERMEDIATE GEAR

DISASSEMBLY AND REASSEMBLY

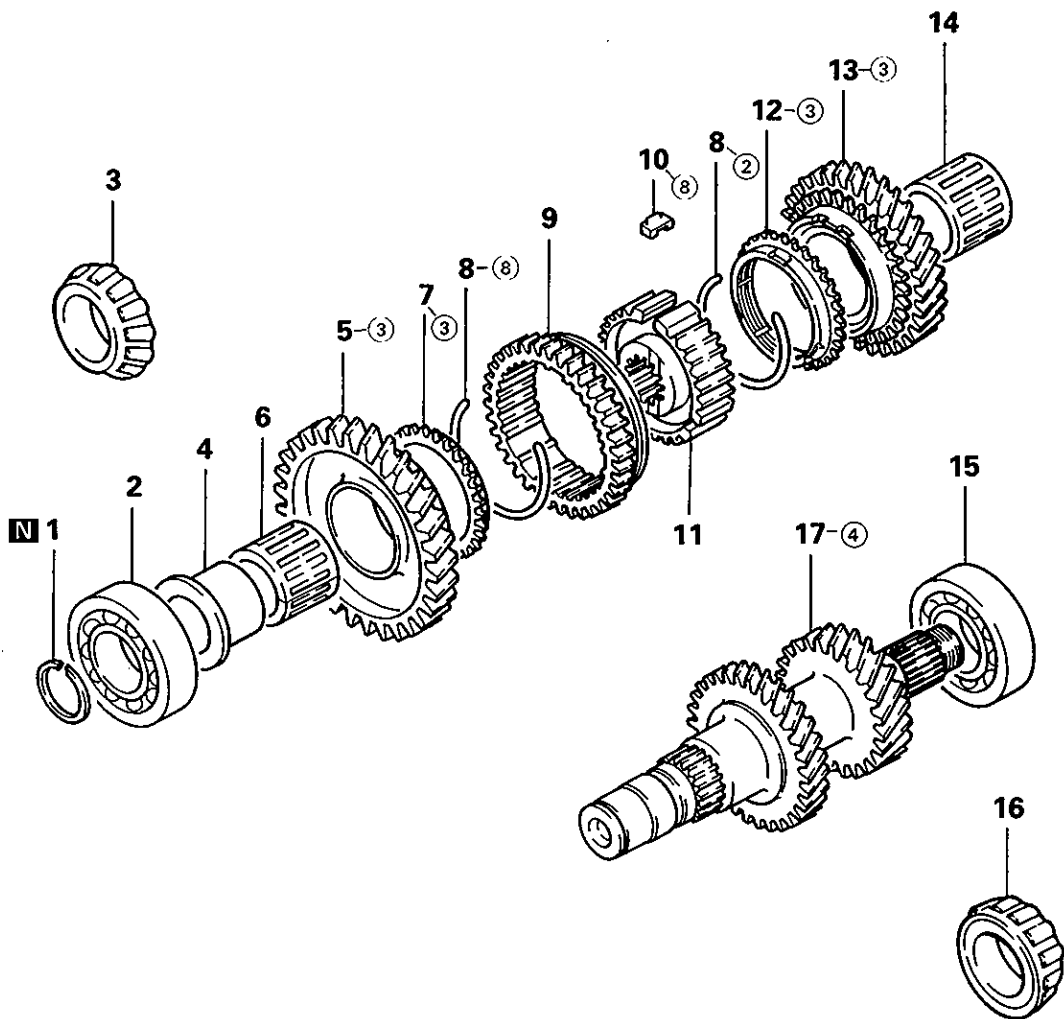

Disassembly steps

- ① I 1. Snap ring
- Ⓐ H 2. Ball bearing (F4M21, F5M21)
- Ⓐ G 3. Taper roller bearing (F5M22, F5M31, F5M33, W5M31, W5M33)
- Ⓐ F 4. Bearing sleeve
- Ⓐ 5. 1st speed gear
- 6. Needle bearing
- 7. Synchronizer ring
- 8. Synchronizer spring
- 9. 1st-2nd speed synchronizer sleeve
- 10. Synchronizer key
- Ⓑ D 11. 1st-2nd speed synchronizer hub
- Ⓑ C 12. Synchronizer ring
- Ⓑ 13. 2nd speed gear
- 14. Needle bearing
- Ⓒ B 15. Ball bearing (F4M21, F5M21)
- Ⓒ A 16. Taper roller bearing (F5M22, F5M31, F5M33, W5M31, W5M33)
- 17. Intermediate gear

NOTE

②③④⑧: Refer to "Details of Change" table

Details of Change

Synchronizer spring for 1st-2nd speed

(New)

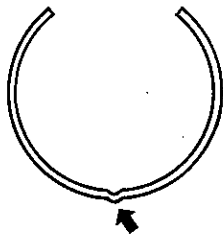

2010069

(Old)

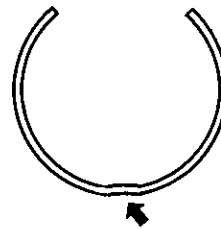

2010044



②

Synchronizer key for 1st-2nd speed

(New)

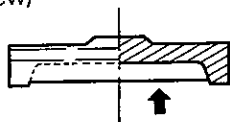

Recess made deeper.

2010073

(Old)

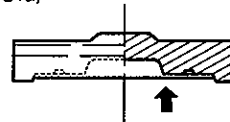

2010045



Synchronizer ring for 1st speed
(F4M21, F5M21, F5M22)

(New)

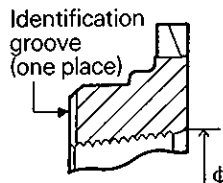

φ62 mm
(2.441 in.)

2010064

(Old)

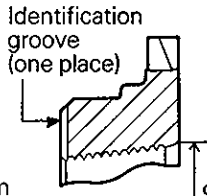

φ63 mm
(2.480 in.)

2010064



Synchronizer ring for 2nd speed
(F4M21, F5M21, F5M22)

(New)

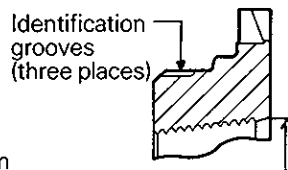

φ62 mm
(2.441 in.)

2010031

(Old)

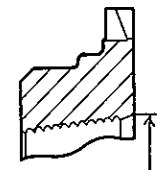

φ63 mm
(2.480 in.)

2010046



Synchronizer ring for 1st speed
(F5M31, W5M31)

Identification groove
(three places)

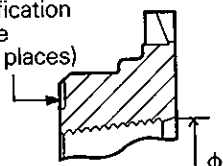

φ71 mm
(2.795 in.)

2010077

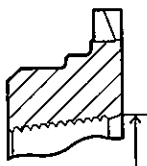

φ72 mm
(2.835 in.)

2010046

Key groove width ... 11.9 mm (0.469 in.)

Synchronizer ring for 2nd speed
(F5M31, W5M31)

Identification grooves
(three places)

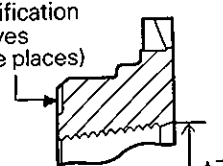

φ71 mm
(2.795 in.)

2010077

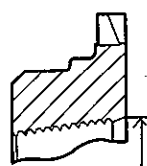

φ72 mm
(2.835 in.)

2010046

Key groove width ... 12.9 mm (0.508 in.)

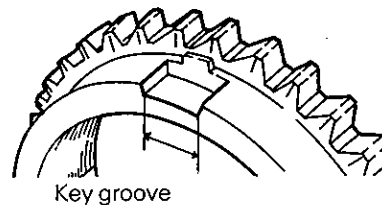

2100036

③

1st speed gear

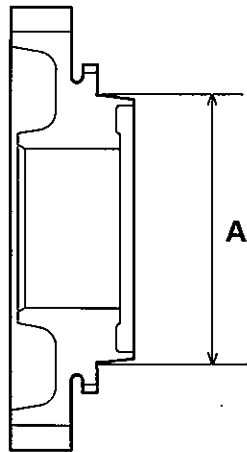

TFM0090

(F4M21, F5M21, F5M22)
 (New) (Old)
 A = 62 mm ← 63 mm

(F5M31, W5M31)
 (New) (Old)
 A = 71 mm ← 72 mm

2nd speed gear

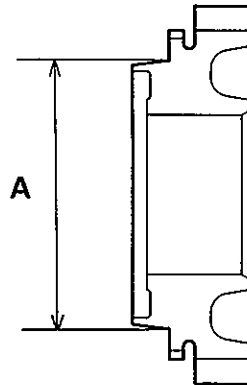

TFM0091

(F4M21, F5M21, F5M22)
 (New) (Old)
 A = 62 mm ← 63 mm

(F5M31, W5M31)
 (New) (Old)
 A = 71 mm ← 72 mm

Intermediate gear (F5M21)

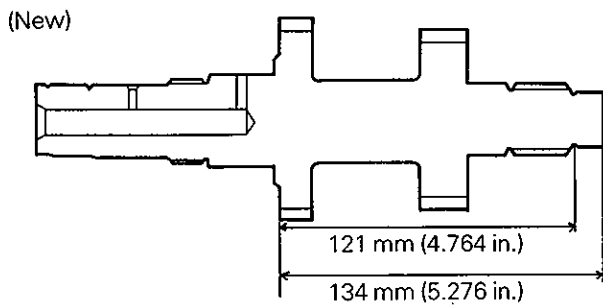

2010053

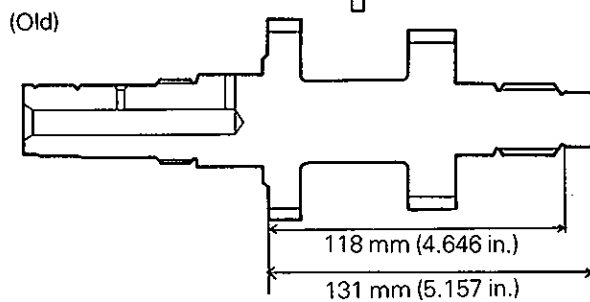

2010053

Intermediate gear (F5M22)

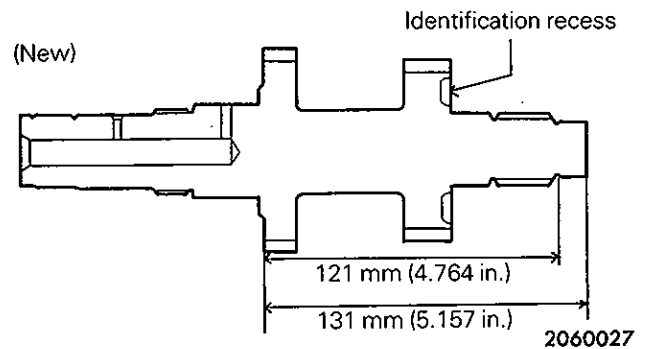

2060027

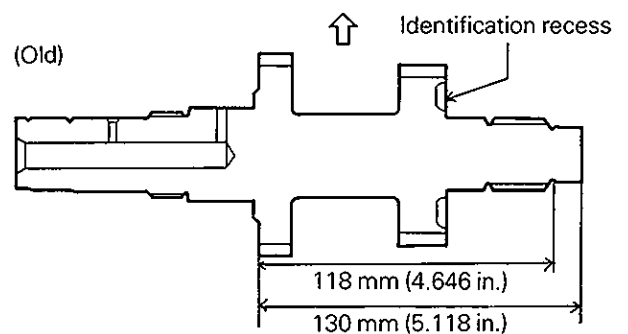

2060027

③

④

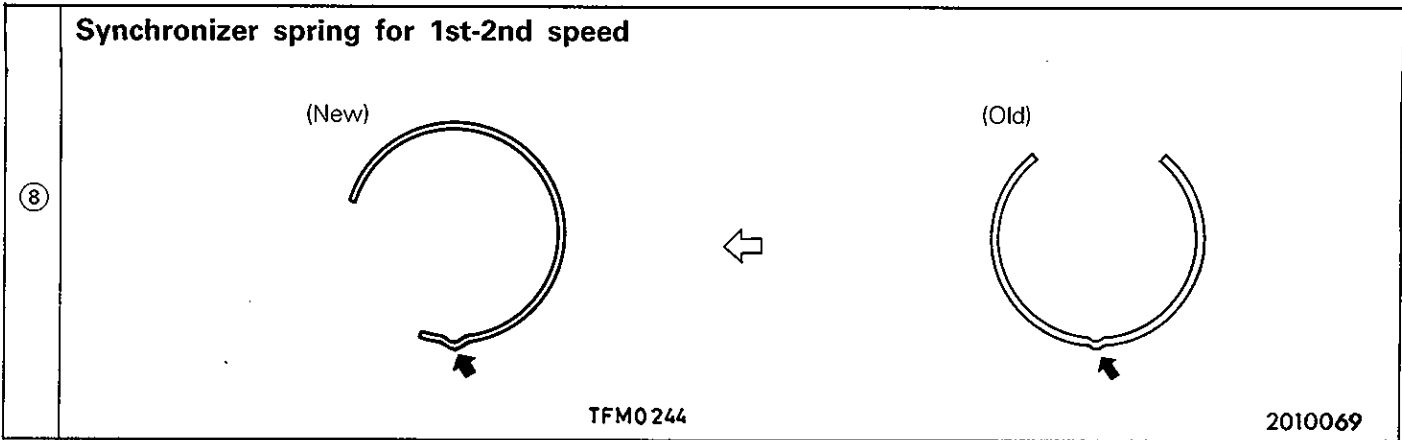

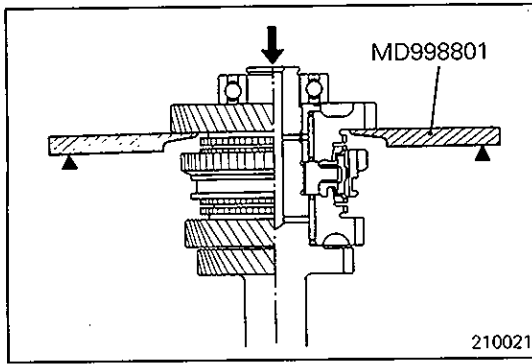

SERVICE POINTS OF DISASSEMBLY

(A) REMOVAL OF BALL BEARING / TAPER ROLLER BEARING / 1ST SPEED GEAR

Caution

- Do not reuse the bearing removed from the shaft.

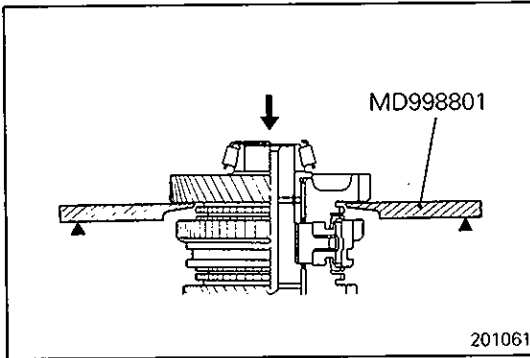

Caution

- Do not reuse the bearing removed from the shaft.
- Replace the inner and outer races of the taper roller bearing as a set.

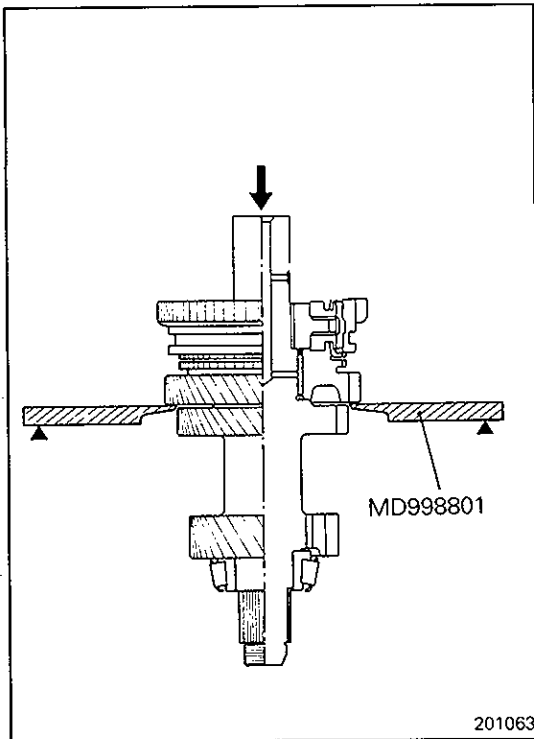

(B) REMOVAL OF 1ST-2ND SPEED SYNCHRONIZER HUB / 2ND SPEED GEAR

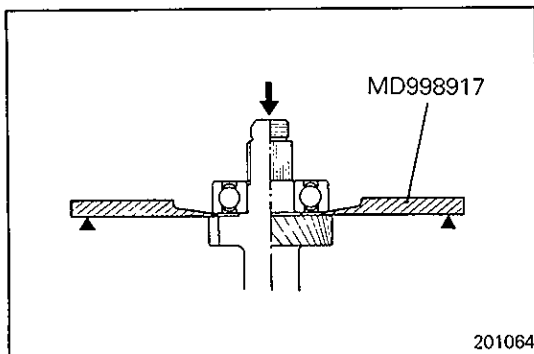

(C) REMOVAL OF BALL BEARING

Caution

- Do not reuse the bearing removed from the shaft.

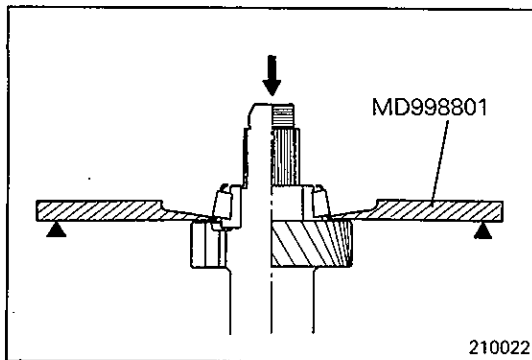

ⓐ REMOVAL OF TAPER ROLLER BEARING

Caution

- Do not reuse the bearing removed from the shaft.
- Replace the inner and outer races of the taper roller bearing as a set.

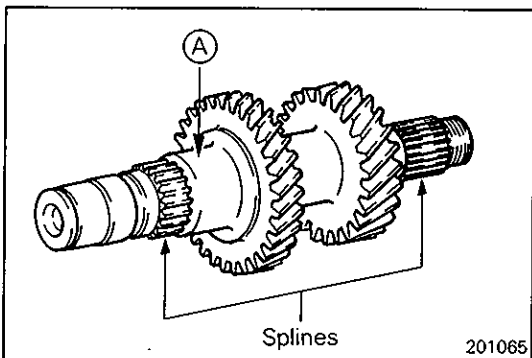

INSPECTION

INTERMEDIATE GEAR

- (1) Check the outer surface of the intermediate gear where the needle bearing is mounted for damage, abnormal wear and seizure [portion (A)].
- (2) Check the splines for damage and wear.

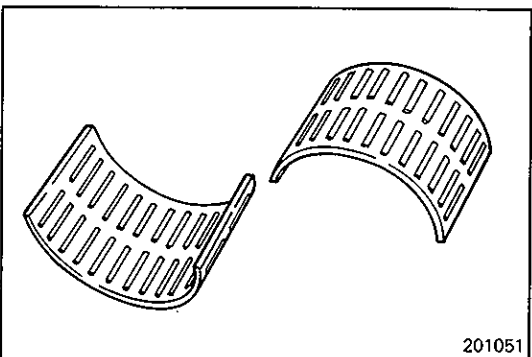

NEEDLE BEARING

- (1) Combine the needle bearing with the shaft or bearing sleeve and gear and check that it rotates smoothly without abnormal noise or play.
- (2) Check the needle bearing cage for deformation.

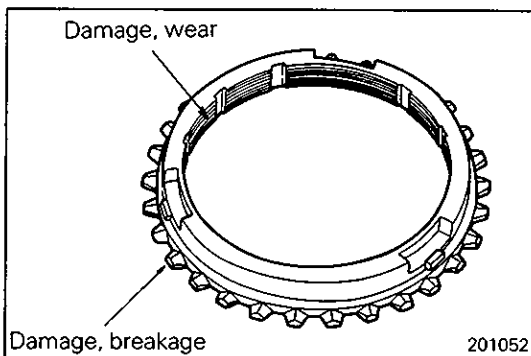

SYNCHRONIZER RING

- (1) Check the clutch gear teeth for damage and breakage.
- (2) Check the internal surface for damage, wear and broken threads.

- (3) Force the synchronizer ring toward the clutch gear and check clearance "A". Replace if it is out of specification.

Limit: 0.5 mm (0.02 in.)

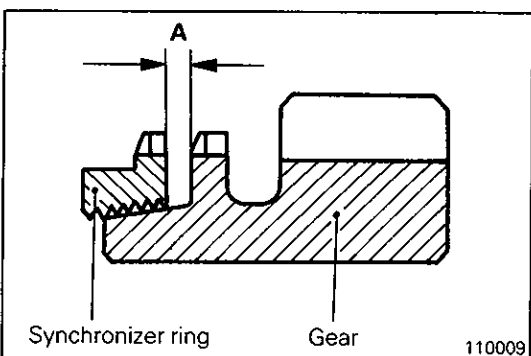

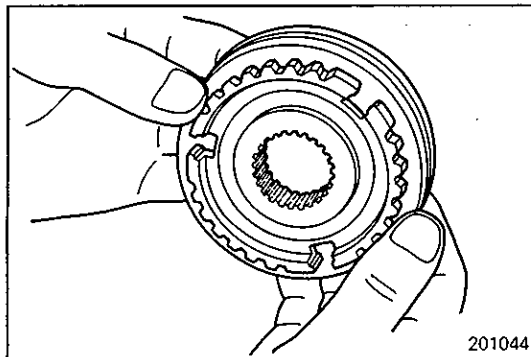

SYNCHRONIZER SLEEVE AND HUB

- (1) Combine the synchronizer sleeve and hub and check that they slide smoothly.
- (2) Check that the sleeve is free from damage at its inside front and rear ends.
- (3) Check for wear of the hub end surfaces (in contact with each speed gear).

Caution

- When replacing, replace the synchronizer hub and sleeve as a set.

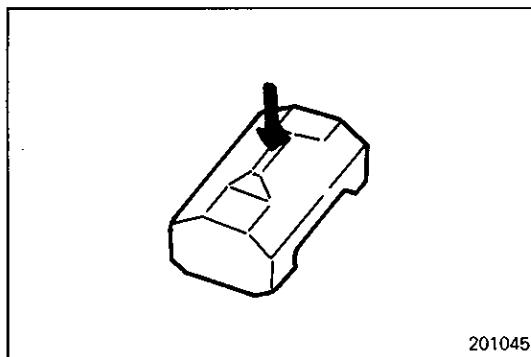

SYNCHRONIZER KEY AND SPRING

- (1) Check for wear of the synchronizer key center protrusion.
- (2) Check the spring for weakness, deformation and breakage.

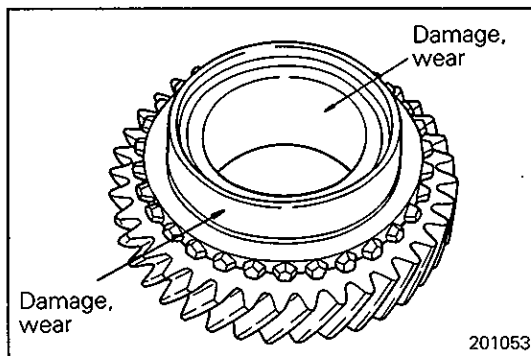

SPEED GEARS

- (1) Check the bevel gear and clutch gear teeth for damage and wear.
- (2) Check the synchronizer cone for rough surface, damage and wear.
- (3) Check the gear bore and front and rear ends for damage and wear.

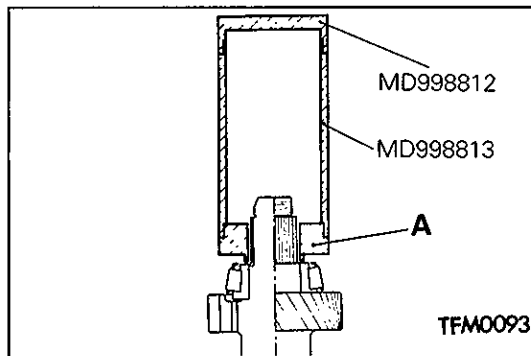

SERVICE POINTS OF REASSEMBLY

A INSTALLATION OF TAPER ROLLER BEARING

Caution

- When installing the bearing, push the inner race only.

	F5M22, F5M31	F5M33, W5M31, W5M33
A	MD998817	MD998818

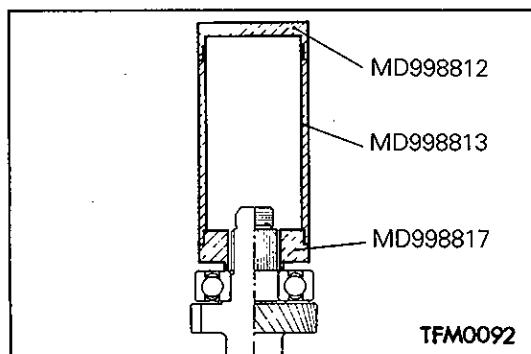

B INSTALLATION OF BALL BEARING

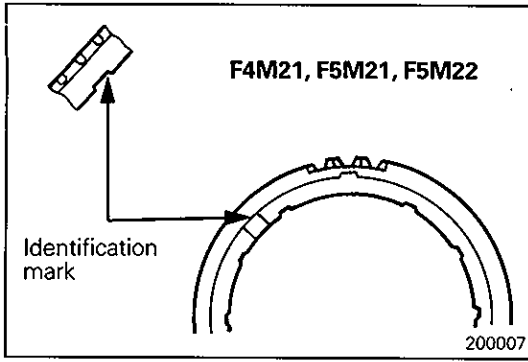

C INSTALLATION OF SYNCHRONIZER RINGS FOR 1ST SPEED GEAR, 2ND SPEED GEAR

- (1) The 1st speed gear and 2nd speed gear of synchronizer rings have an identification mark.

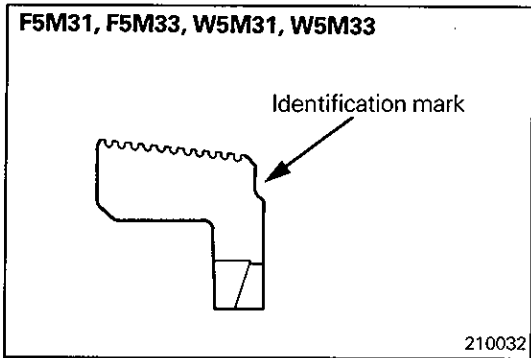

D INSTALLATION OF 1ST-2ND SPEED SYNCHRONIZER HUB / SYNCHRONIZER KEY / 1ST-2ND SYNCHRONIZER SLEEVE

- (1) Combine the 1st-2nd speed synchronizer hub and sleeve as illustrated.

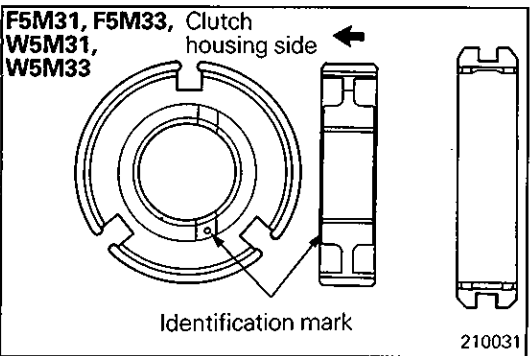
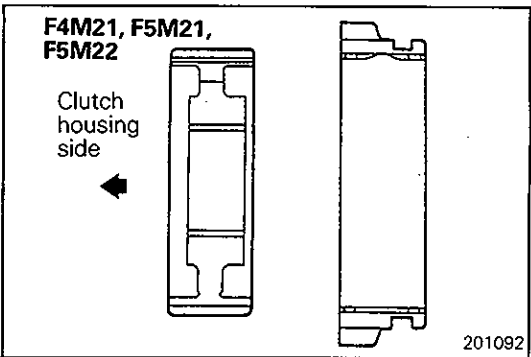

- (2) The synchronizer sleeve has tooth missing at six portions. Assemble the hub to the sleeve in such a way that the center tooth "T" between two missing teeth will touch the synchronizer key.

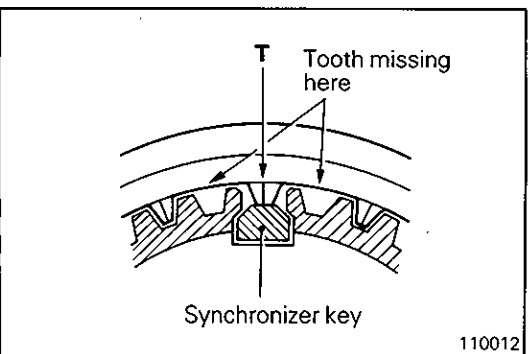

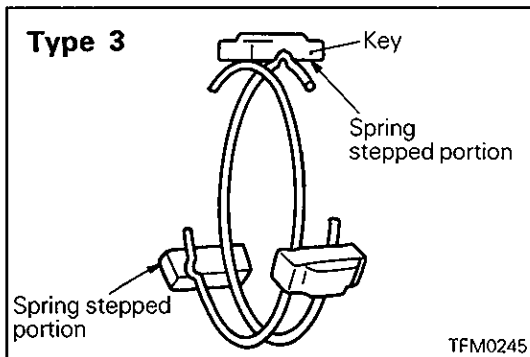
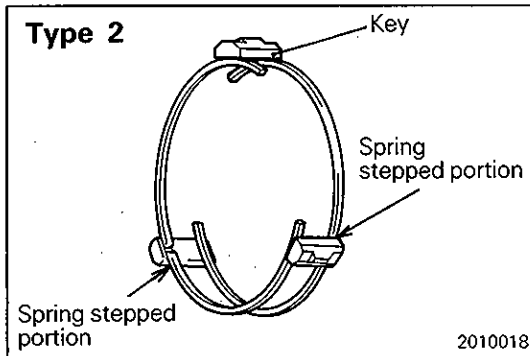
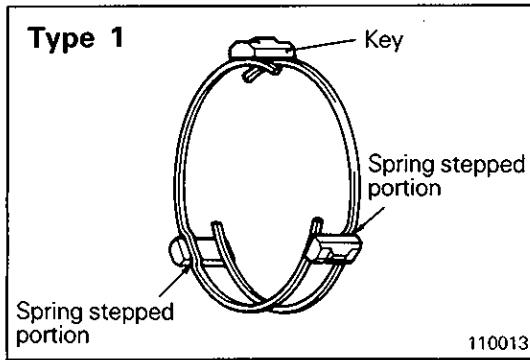

E INSTALLATION OF SYNCHRONIZER SPRING

- (1) Stagger the two synchronizer springs and place them so that the spring steps are on different synchronizer keys.
- (2) Do not mix types 1, 2 and 3 springs with one another.

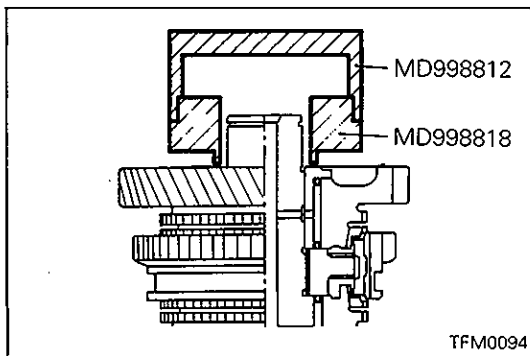

F INSTALLATION OF BEARING SLEEVE

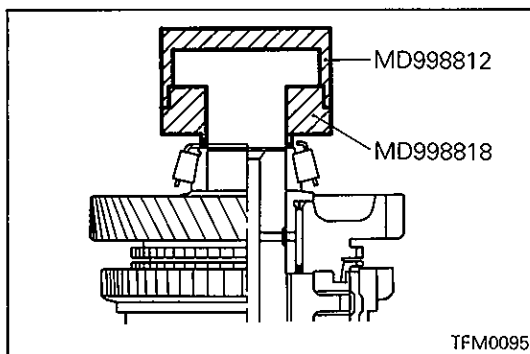

G INSTALLATION OF TAPER ROLLER BEARING

Caution

- When installing the bearing, push the inner race only.

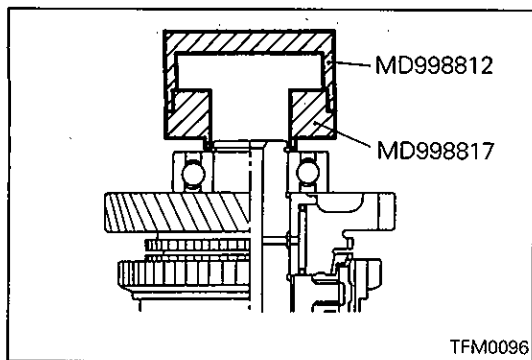
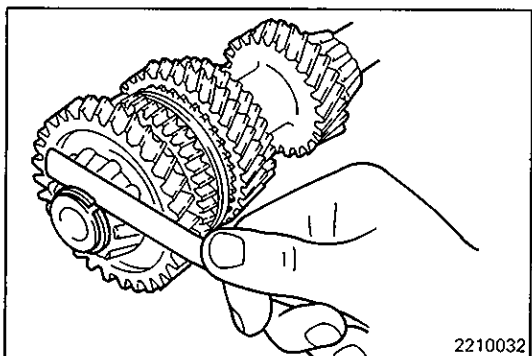
**H** INSTALLATION OF BALL BEARING**I** INSTALLATION OF SNAP RING

- (1) Select and install the snap ring that gives standard intermediate gear bearing end play.

Standard value:**Intermediate gear bearing end play:**

0.01 – 0.11 mm (0.0004 – 0.0043 in.) (F5M31, W5M31)

0.01 – 0.14 mm (0.0004 – 0.0055 in.) (F4M21, F5M21, F5M22, F5M33, W5M33)

7. OUTPUT SHAFT

DISASSEMBLY AND REASSEMBLY

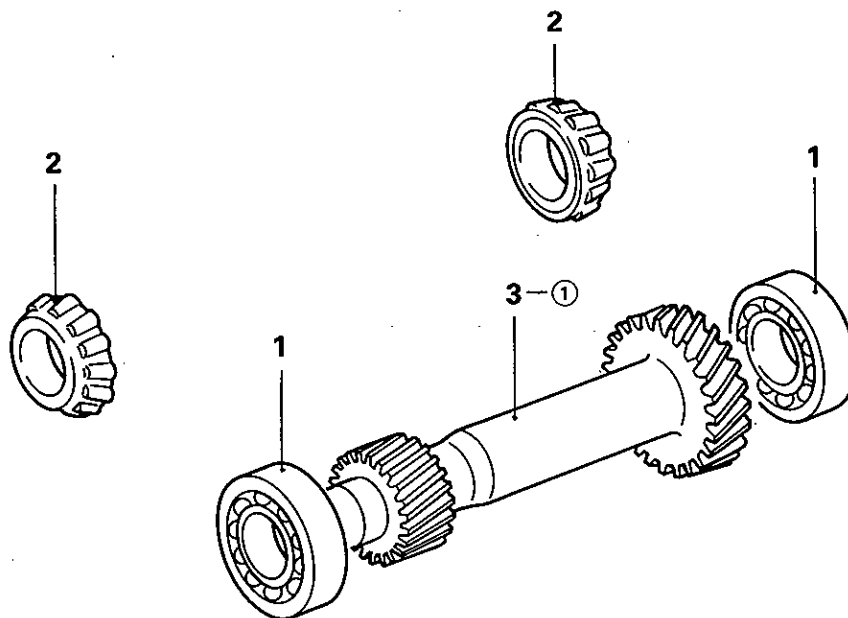

Disassembly steps

- Ⓐ Ⓑ 1. Ball bearing (Up to JUN. 1987 – F4M21, F5M21)
- Ⓑ Ⓐ 2. Taper roller bearing (F5M22, F5M31, F5M33, W5M31) (From JUL. 1987 – F4M21, F5M21)
- 3. Output shaft

NOTE
 ①: Refer to "Details of Change" table.

201071

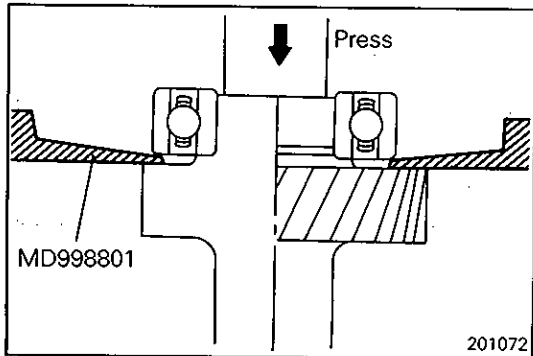

SERVICE POINTS OF DISASSEMBLY

Ⓐ REMOVAL OF BALL BEARINGS

Caution

- Do not reuse the bearings removed from the shaft.

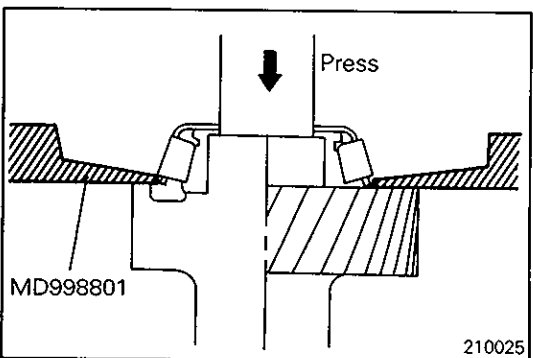

Ⓑ REMOVAL OF TAPER ROLLER BEARINGS

Caution

- Do not reuse the bearings removed from the shaft.
- Replace the inner and outer races of the taper roller bearing as a set.

Details of Change

Output shaft

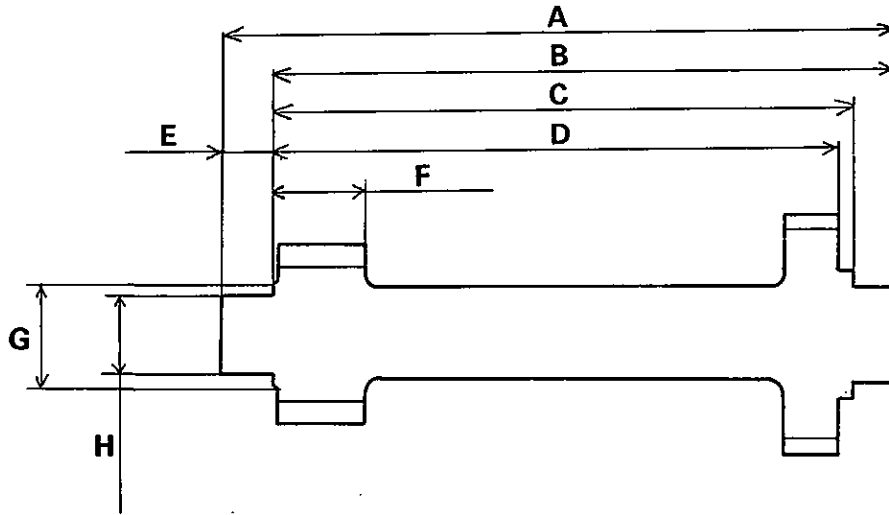

①

2010054

mm (in.)

	(New)	(Old)
A	214.7 (8.453)	216.5 (8.524)
B	199.2 (7.843)	199.5 (7.854)
C	183.7 (7.232)	184.5 (7.264)
D	182.2 (7.173)	181.5 (7.146)
E	15.5 (0.610)	17 (0.669)
F	30 (1.181)	29.1 (1.146)
G	40 (1.575)	33 (1.299)
H	30 (1.181)	25 (0.984)

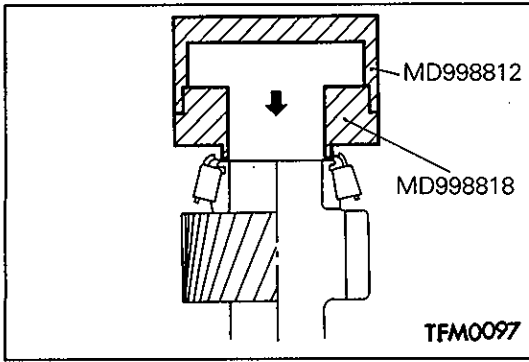

SERVICE POINTS OF REASSEMBLY

A INSTALLATION OF TAPER ROLLER BEARINGS

Caution

- When installing the bearing, push the inner race only.

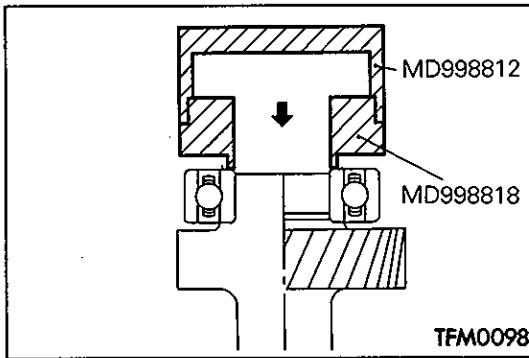

B INSTALLATION OF BALL BEARINGS

NOTES

8. FRONT OUTPUT SHAFT

W5M31

DISASSEMBLY AND REASSEMBLY

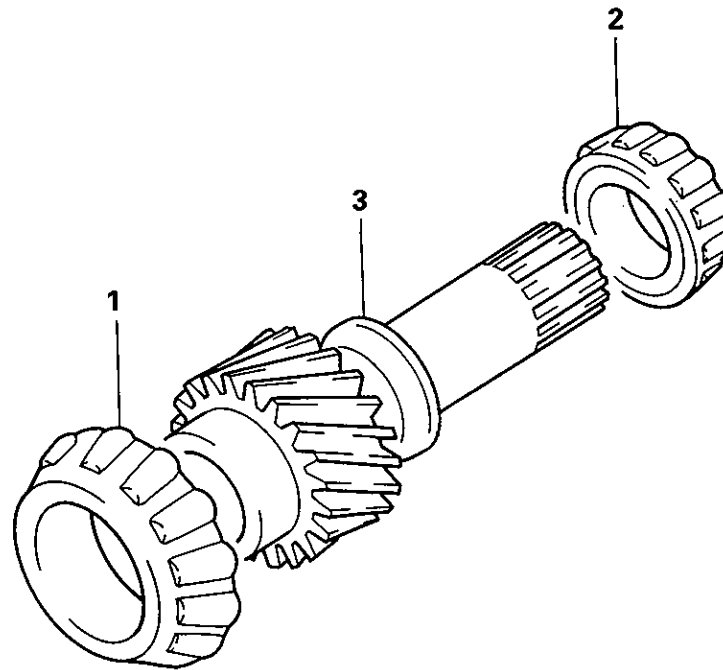

Disassembly steps

- Ⓐ Ⓑ 1. Taper roller bearing
- Ⓐ Ⓐ 2. Taper roller bearing
- 3. Front output shaft

2200075

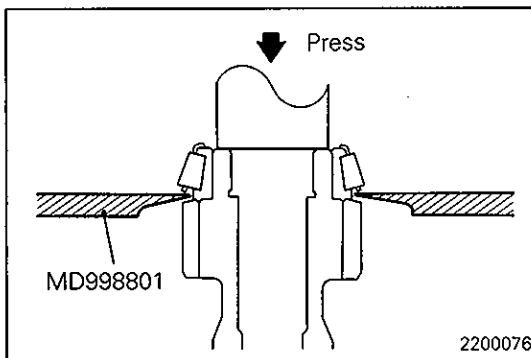

SERVICE POINTS OF DISASSEMBLY

Ⓐ REMOVAL OF TAPER ROLLER BEARINGS

- (1) Remove the taper roller bearings using the special tool.

NOTE

- (1) Do not reuse the bearing removed from the shaft.
- (2) Replace the inner and outer races of the taper roller bearing as a set.

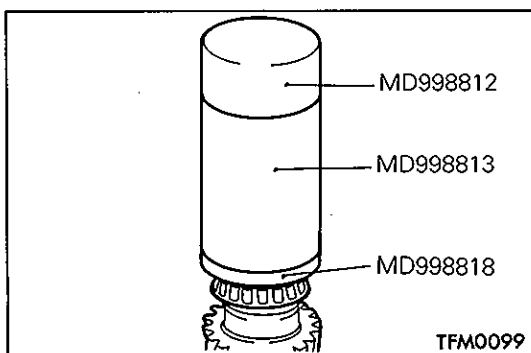

SERVICE POINTS OF REASSEMBLY

Ⓐ INSTALLATION OF TAPER ROLLER BEARINGS

- (1) Install the taper roller bearing using the special tool.

NOTE

- Apply the special tool to the inner race only when installing the bearing.

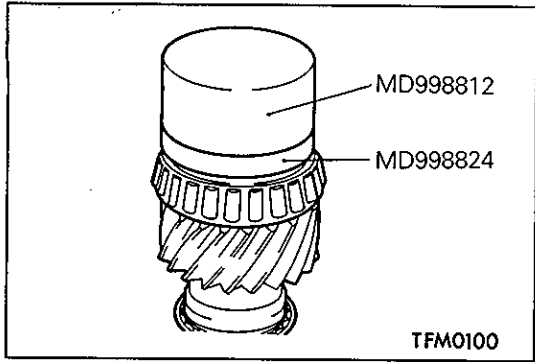
**B INSTALLATION OF TAPER ROLLER BEARINGS**

(1) Install the taper roller bearing using the special tool.

NOTE

Apply the special tool to the inner race only when installing the bearing.

9. DIFFERENTIAL

DISASSEMBLY AND REASSEMBLY

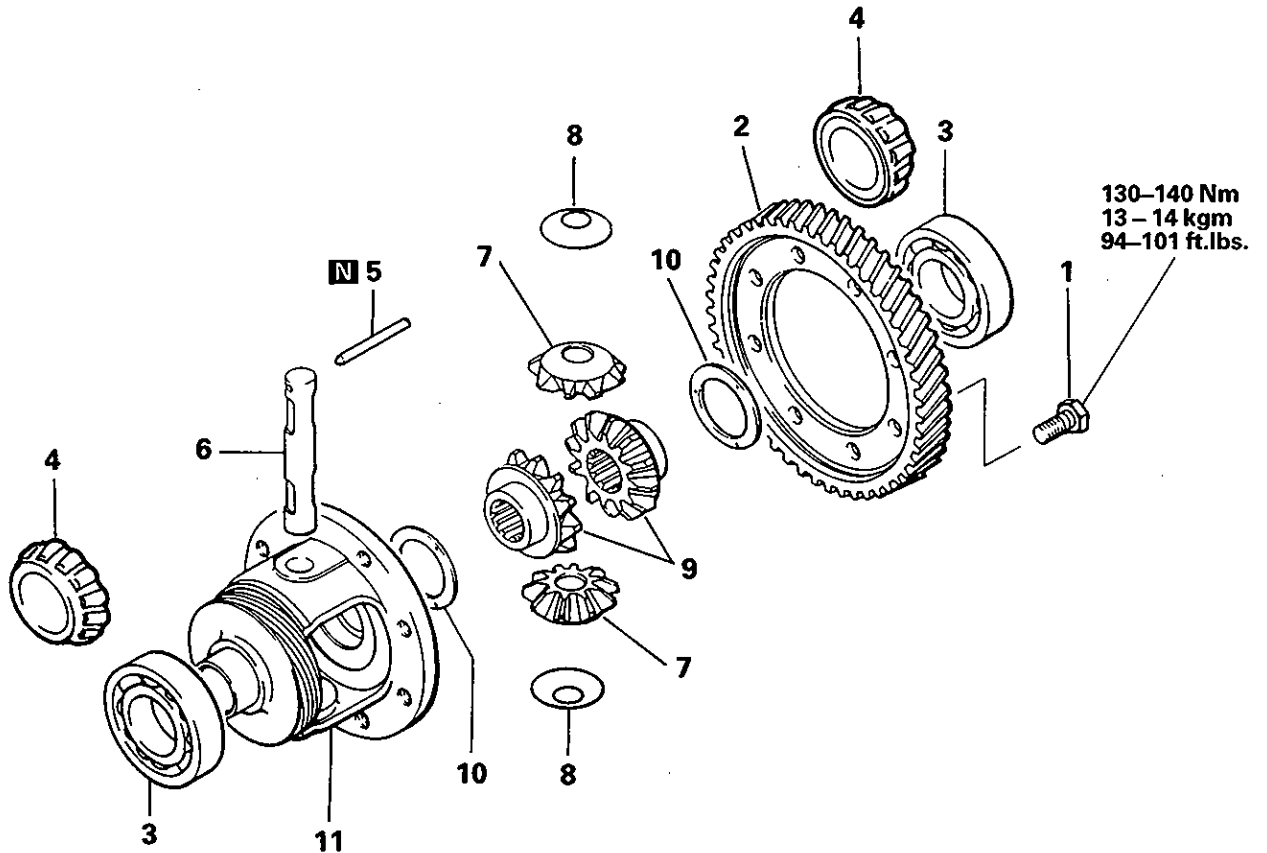

Disassembly steps

- E** 1. Bolt
- 2. Differential drive gear
- A** **D** 3. Ball bearing (F4M21, F5M21, W5M31, W5M33)
- B** **C** 4. Taper roller bearing (F5M22, F5M31, F5M33)
- C** **B** 5. Lock pin
- A** 6. Pinion shaft
- A** 7. Pinion
- A** 8. Washer
- A** 9. Side gear
- A** 10. Spacer
- 11. Differential case

160119

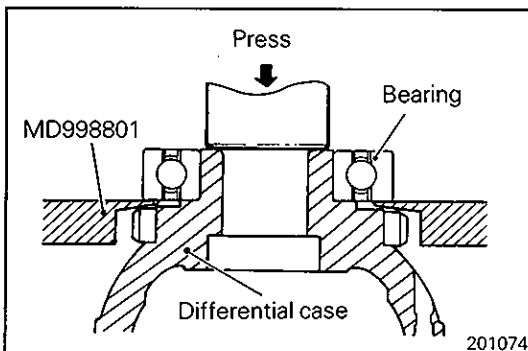

SERVICE POINTS OF DISASSEMBLY

A REMOVAL OF BALL BEARINGS

Caution

- Do not reuse the bearing removed from the shaft.

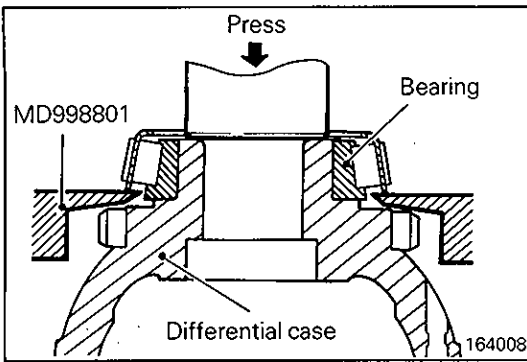
**ⓑ REMOVAL OF TAPER ROLLER BEARING****Caution**

- Do not reuse the bearing removed from the shaft.
- Replace the inner and outer races of the taper roller bearing as a set.

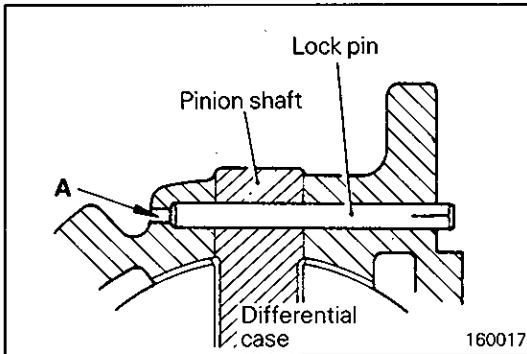
**ⓒ REMOVAL OF LOCK PIN**

- (1) Drive out the lock pin from the hole A using a punch.

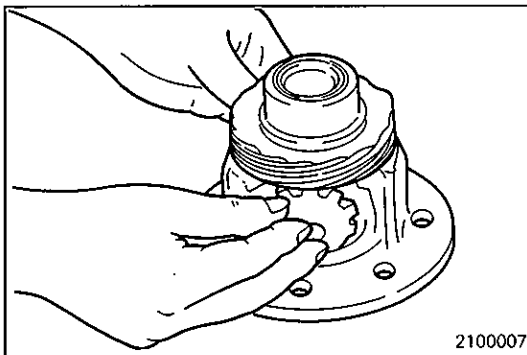
**SERVICE POINTS OF REASSEMBLY****Ⓐ INSTALLATION OF SPACER / SIDE GEAR / WASHER / PINION / PINION SHAFT**

- (1) Install the spacer on the back of the side gear and then install the gear in the differential case.

Caution

- When installing a new side gear, use a spacer of medium thickness [0.93 – 1.00 mm (0.366 – 0.394 in.)].

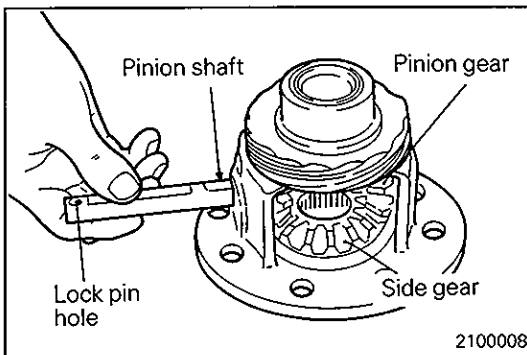

- (2) Set the washer on the back of each pinion and insert the two pinions to specified position while engaging them with the side gears and turning them.
- (3) Insert the pinion shaft.

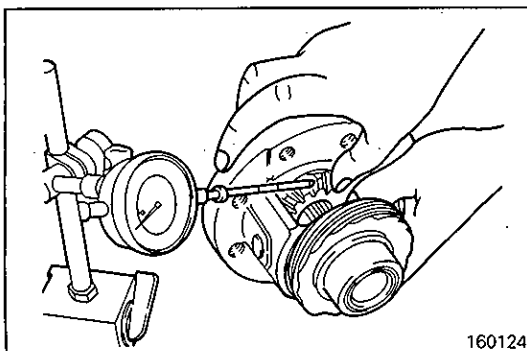

- (4) Measure the backlash between the side gears and pinions.

Standard value:

0.025 – 0.150 mm (0.001 – 0.006 in.)

- (5) If the backlash is out of specification, disassemble again and using correct spacer, reassemble and adjust.

Caution

- Adjust for same backlash of both side gears.

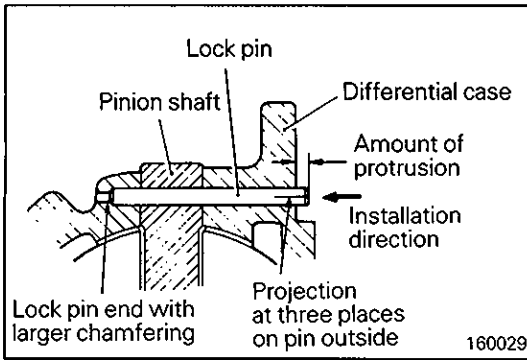

B INSTALLATION OF LOCK PIN

- (1) Align the pinion shaft lock pin hole with the case lock pin hole and insert the lock pin.

Caution

- Do not reuse the lock pin.
- The lock pin must not protrude more than 3 mm (0.118 in.). (F4M21, F5M21)
- The lock pin head must be sunk from the flange surface of the differential case. (F5M22, F5M31, F5M33, W5M31, W5M33)

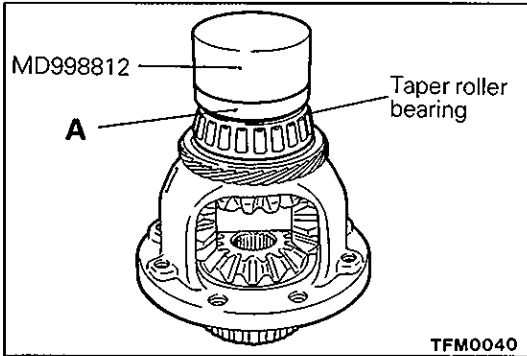

C INSTALLATION OF TAPER ROLLER BEARINGS

Caution

- When press-fitting the bearings, push the inner race only.

	F5M22	F5M31, F5M33
A	MD998819	MD998822

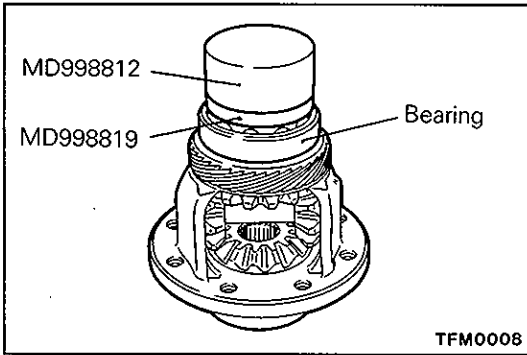

D INSTALLATION OF BALL BEARINGS

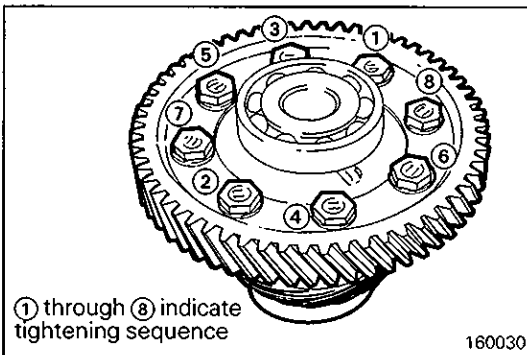

E INSTALLATION OF BOLTS

- (1) Apply specified sealant to the entire threads of the bolts and quickly tighten in the order shown to specified torque.

Specified sealant: 3M Stud Locking No. 4170 or equivalent

Caution

- If a bolt is reused, remove traces of old sealant completely from the threads.

NOTES

10. CENTER DIFFERENTIAL
<FOUR WHEEL DRIVE MODEL ONLY>

DISASSEMBLY AND REASSEMBLY

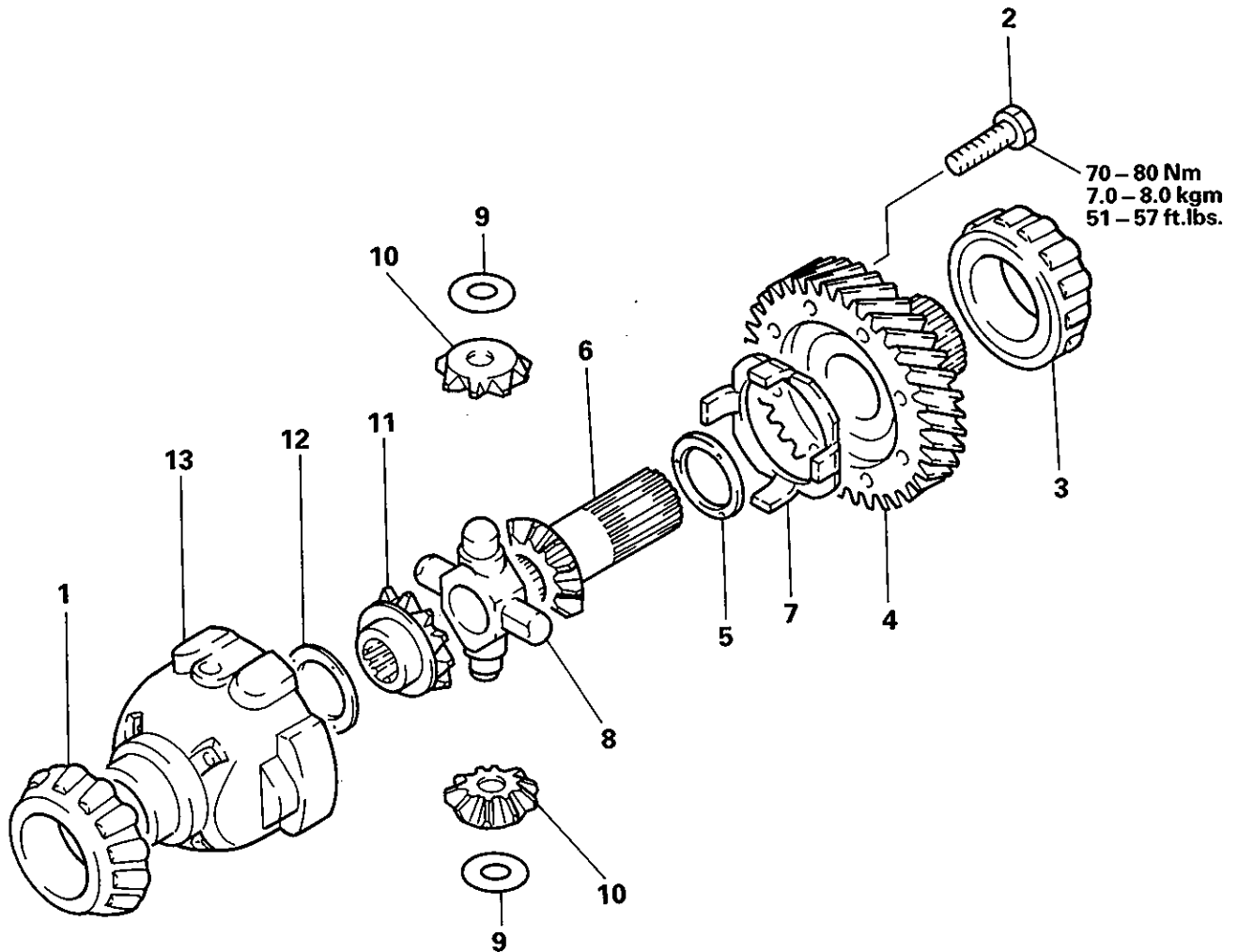

Disassembly steps

- (A) (D) 1. Taper roller bearing
- (A) (C) 2. Bolt
- (A) (B) 3. Taper roller bearing
- 4. Output gear
- (A) 5. Spacer
- 6. Side gear
- 7. Pinion shaft retainer (with differential lock)
- 8. Pinion shaft
- 9. Washer
- 10. Pinion
- 11. Side gear
- (A) 12. Spacer
- 13. Center differential case

W5M33

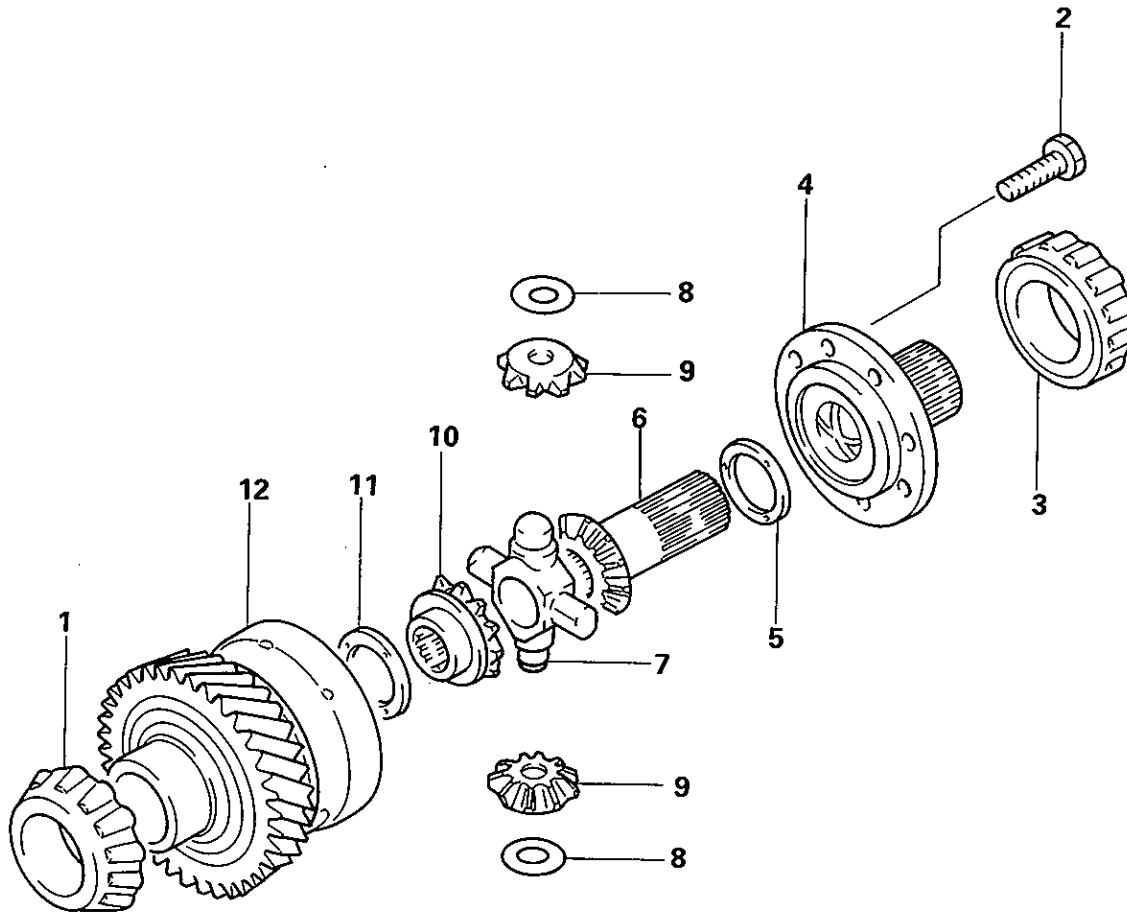
**Disassembly steps**

- Ⓐ

D

 1. Taper roller bearing
- Ⓐ

C

 2. Bolt
- Ⓐ

B

 3. Taper roller bearing
- 4. Output flange
- Ⓐ 5. Spacer
- 6. Side gear
- 7. Pinion shaft
- 8. Washer
- 9. Pinion
- 10. Side gear
- Ⓐ 11. Spacer
- 12. Center differential case

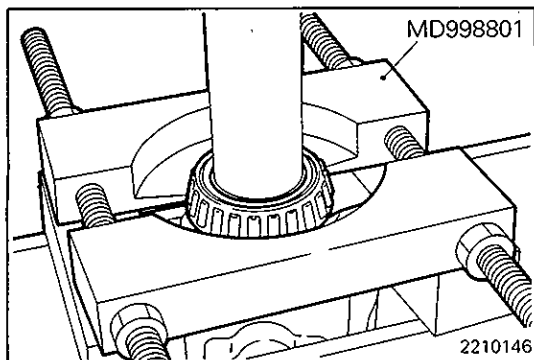

SERVICE POINTS OF DISASSEMBLY

A REMOVAL OF TAPER ROLLER BEARINGS

- (1) Remove the taper roller bearings using the special tool.

NOTE

- (1) Do not reuse the bearing removed from the shaft.
- (2) Replace the inner and outer races of the taper roller bearing as a set.

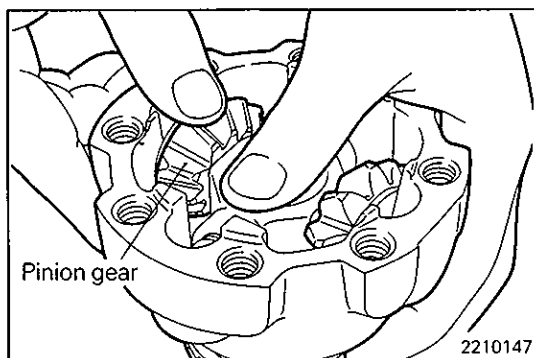

SERVICE POINTS OF REASSEMBLY

A INSTALLATION OF SPACERS

- (1) Install the spacer, side gear, pinion gear, washer and pinion shaft to the center differential case.
- (2) Holding down the pinion shaft, select the spacer of maximum thickness that allows the pinion gear to turn lightly and install it to the shaft.
- (3) Install the side gear, spacer, pinion shaft retainer (KM220 only) and output gear and tighten the bolt to specified torque.
- (4) Select the spacer of maximum thickness that allows the side gear to turn lightly and install it.
- (5) Check that both side gears turn lightly.

Standard value:

Center differential side gear end play:
 0.05 – 0.25 mm (0.0020 – 0.0010 in.)

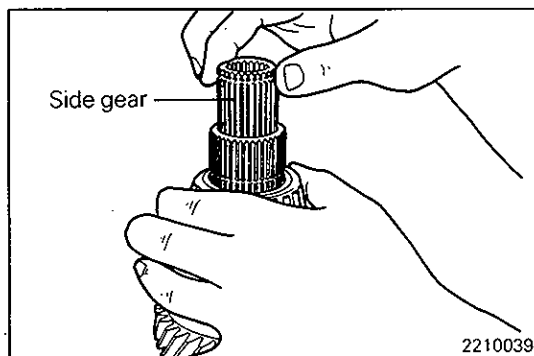

B INSTALLATION OF TAPER ROLLER BEARINGS

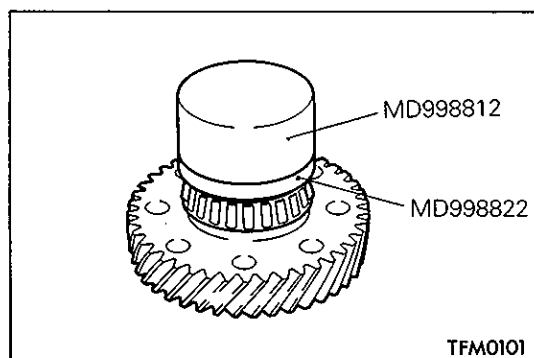

C INSTALLATION OF BOLTS

- (1) Apply specified sealant to the entire threads of the bolts and quickly tighten the bolts in the order shown to specified torque.

Specified sealant: 3M STUD Locking No. 4170 or equivalent

NOTE

If the bolts are reused, completely remove old sealant from the threads.

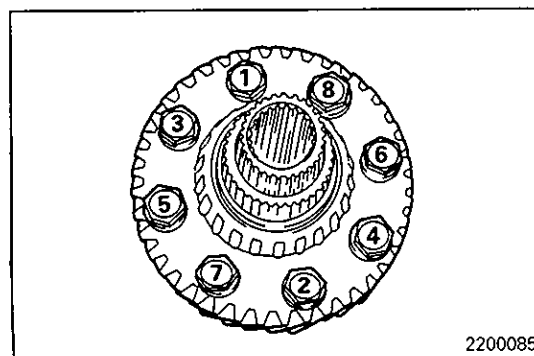

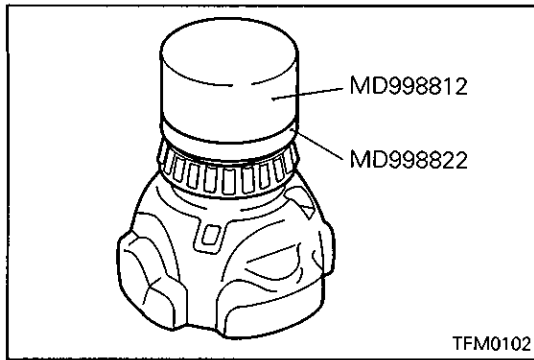
**D INSTALLATION OF TAPER ROLLER BEARINGS**

NOTE

Apply the special tool to the inner race only when installing the bearing.

11. TRANSMISSION CASE ADAPTER

<FOUR WHEEL DRIVE MODEL WITH DIFFERENTIAL LOCK>

DISASSEMBLY AND REASSEMBLY

15 – 22 Nm
1.5 – 2.2 kgm
11 – 15 ft.lbs.

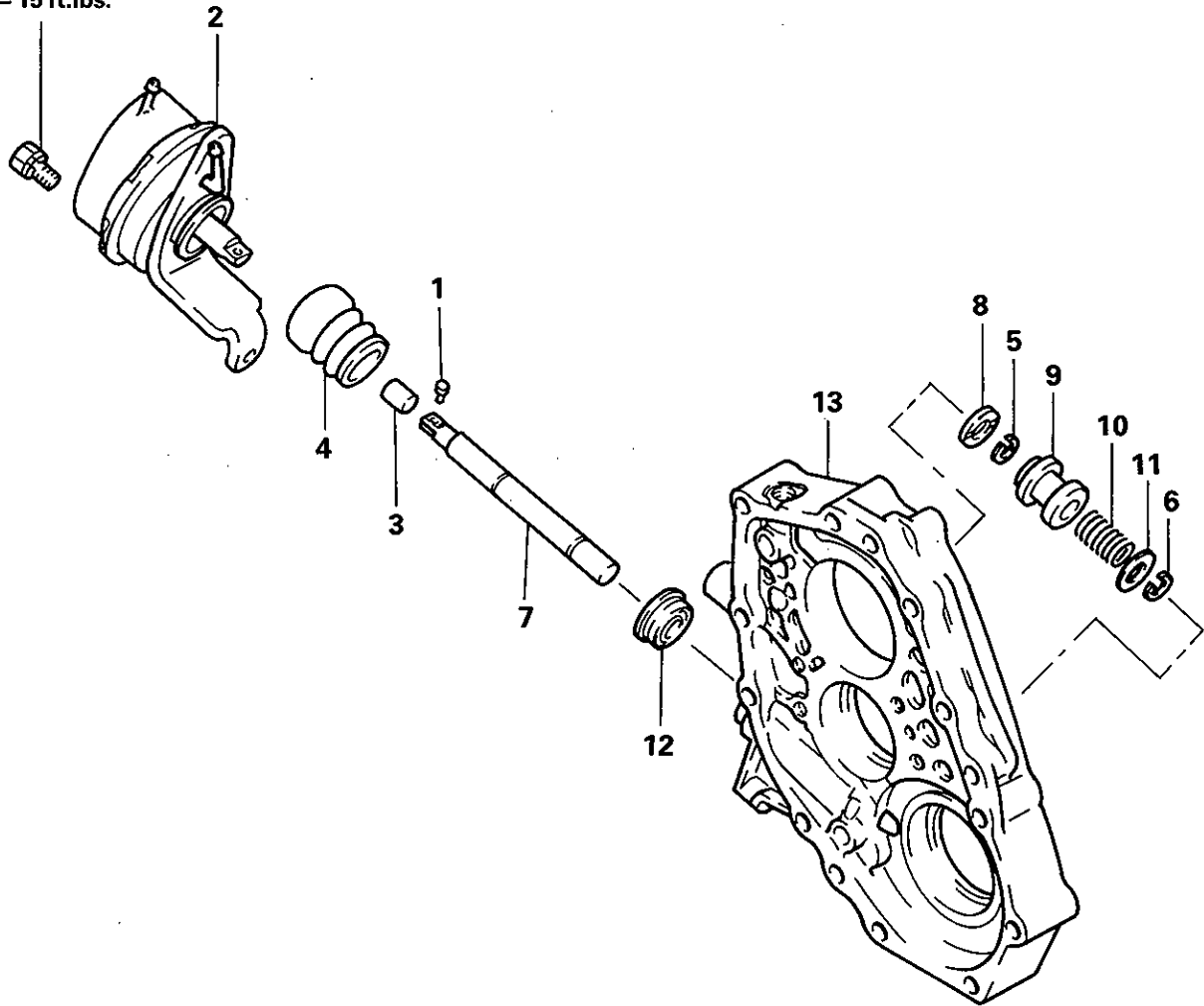

Disassembly steps

- (A) (B) 1. Pin
- (B) 2. Actuator assembly
- (B) 3. Collar
- 4. Boot
- 5. Snap ring
- 6. Snap ring
- 7. Differential lock shift rod
- 8. Seat
- 9. Differential lock shift lug
- 10. Spring
- 11. Washer
- (A) 12. Oil seal
- 13. Transmission case adapter

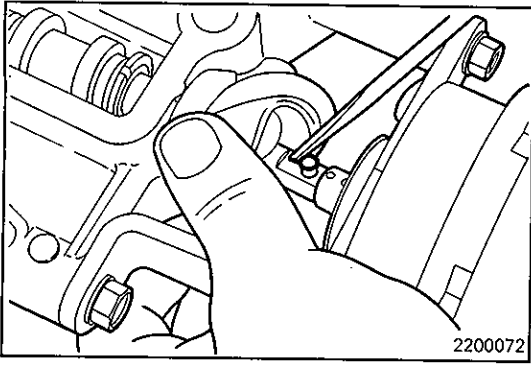

SERVICE POINTS OF DISASSEMBLY

A REMOVAL OF PIN

- (1) Slide the collar toward the actuator and remove the pin.

SERVICE POINTS OF REASSEMBLY

A INSTALLATION OF OIL SEAL

- (1) Pack the lip of the oil seal with grease and install the seal using socket wrench (14 mm).

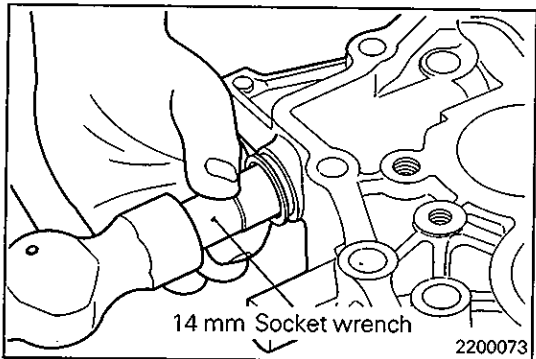

B INSTALLATION OF PIN / ACTUATOR ASSEMBLY / COLLAR

- (1) Install the collar over the actuator rod.
- (2) Connect the shift rod to the actuator rod and align the pin holes.
- (3) Insert the pin with its head at the top.

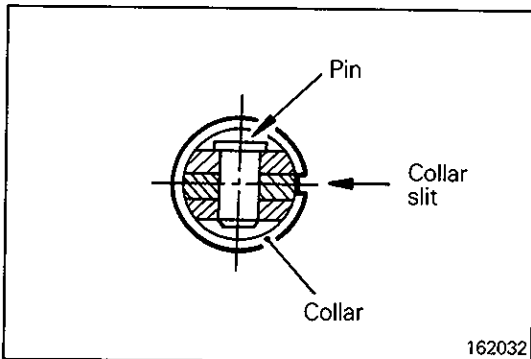

- (4) Slide the collar to the illustrated position. Make sure that the collar slit is at right angle to the pin.

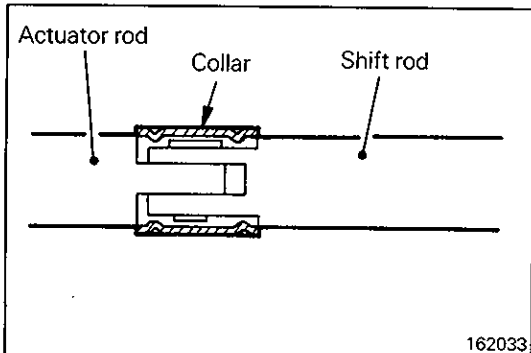
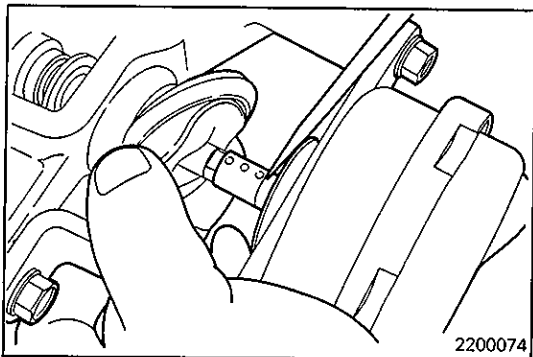

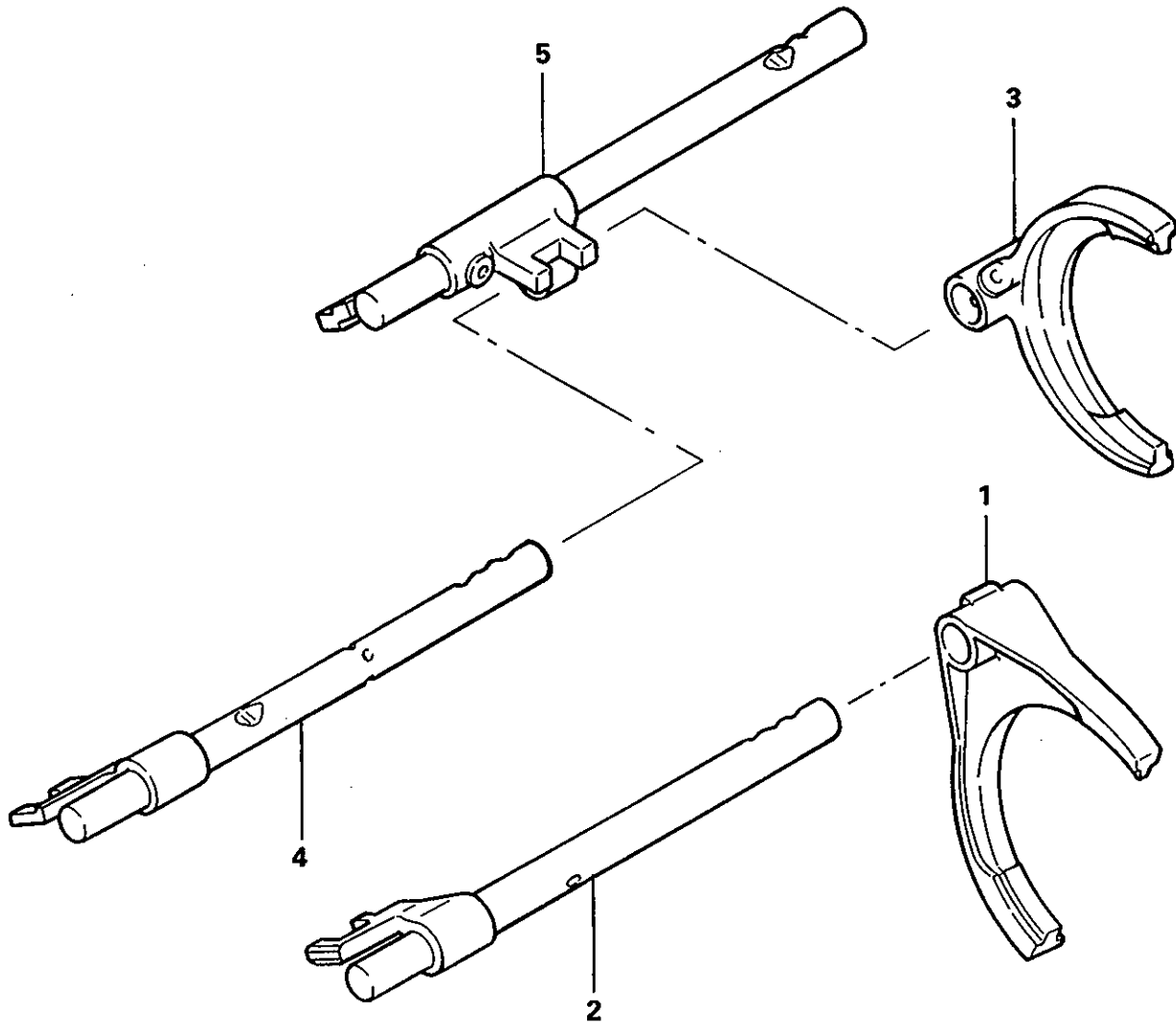
12. SHIFT FORK**F4M21****DISASSEMBLY AND REASSEMBLY****Disassembly steps**

1. 1st-2nd speed shift fork
2. 1st-2nd speed shift rail
3. 3rd-4th speed shift fork
4. 3rd-4th speed shift rail
5. Reverse shift rail

200005

F5M21, F5M22

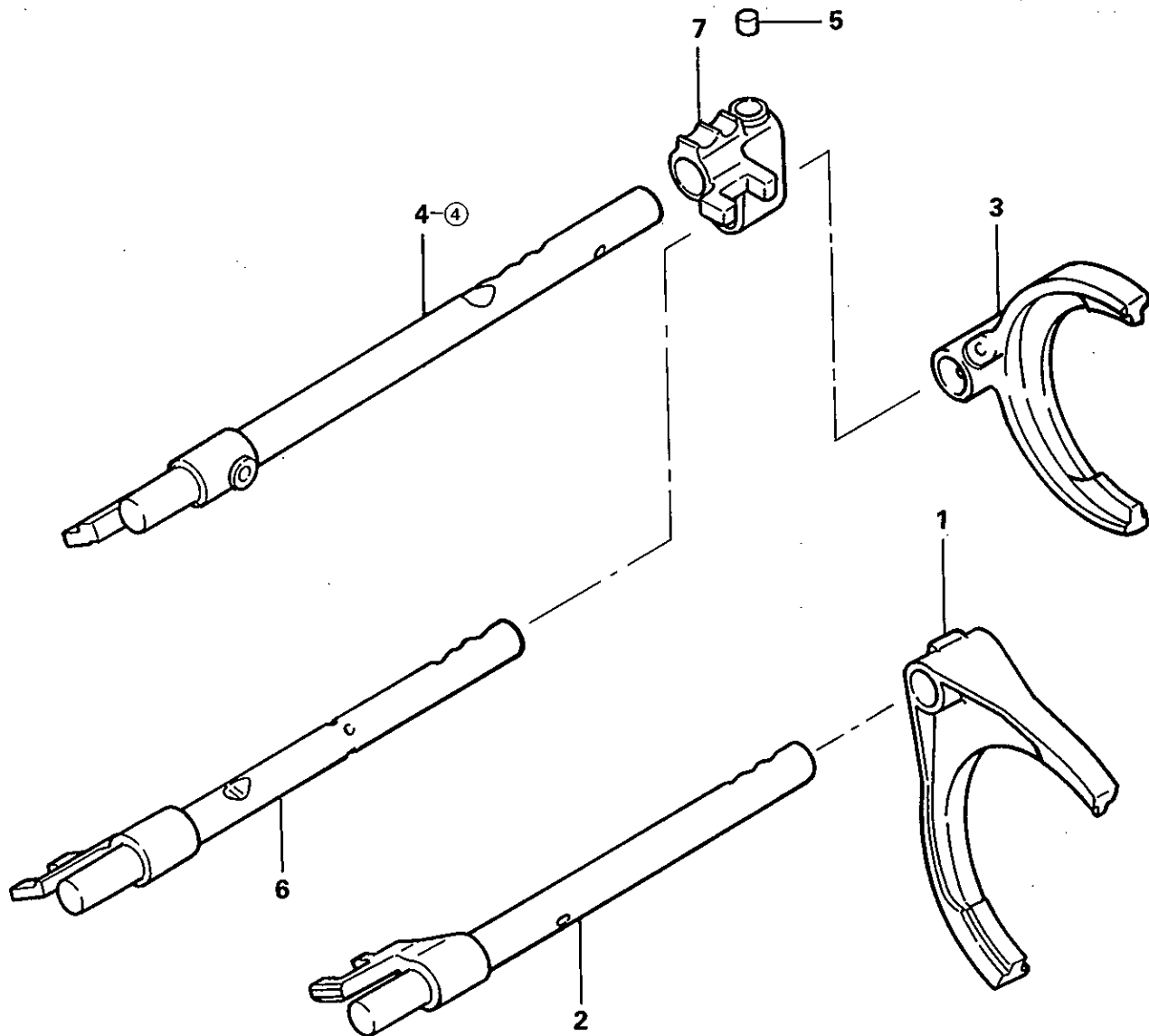

Disassembly steps

1. 1st-2nd speed shift fork
2. 1st-2nd speed shift rail
3. 3rd-4th speed shift fork
4. 5th-reverse speed shift rail
5. Interlock plunger
6. 3rd-4th speed shift rail
7. Reverse shift lug

A

NOTE

④: Refer to "Details of Change" table.

201073

SERVICE POINTS OF REASSEMBLY

A **INSTALLATION OF INTERLOCK PLUNGER**

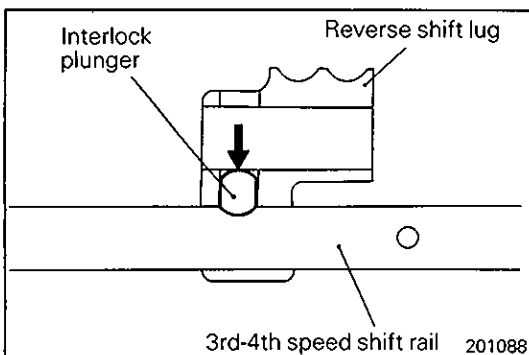

201088

Details of Change

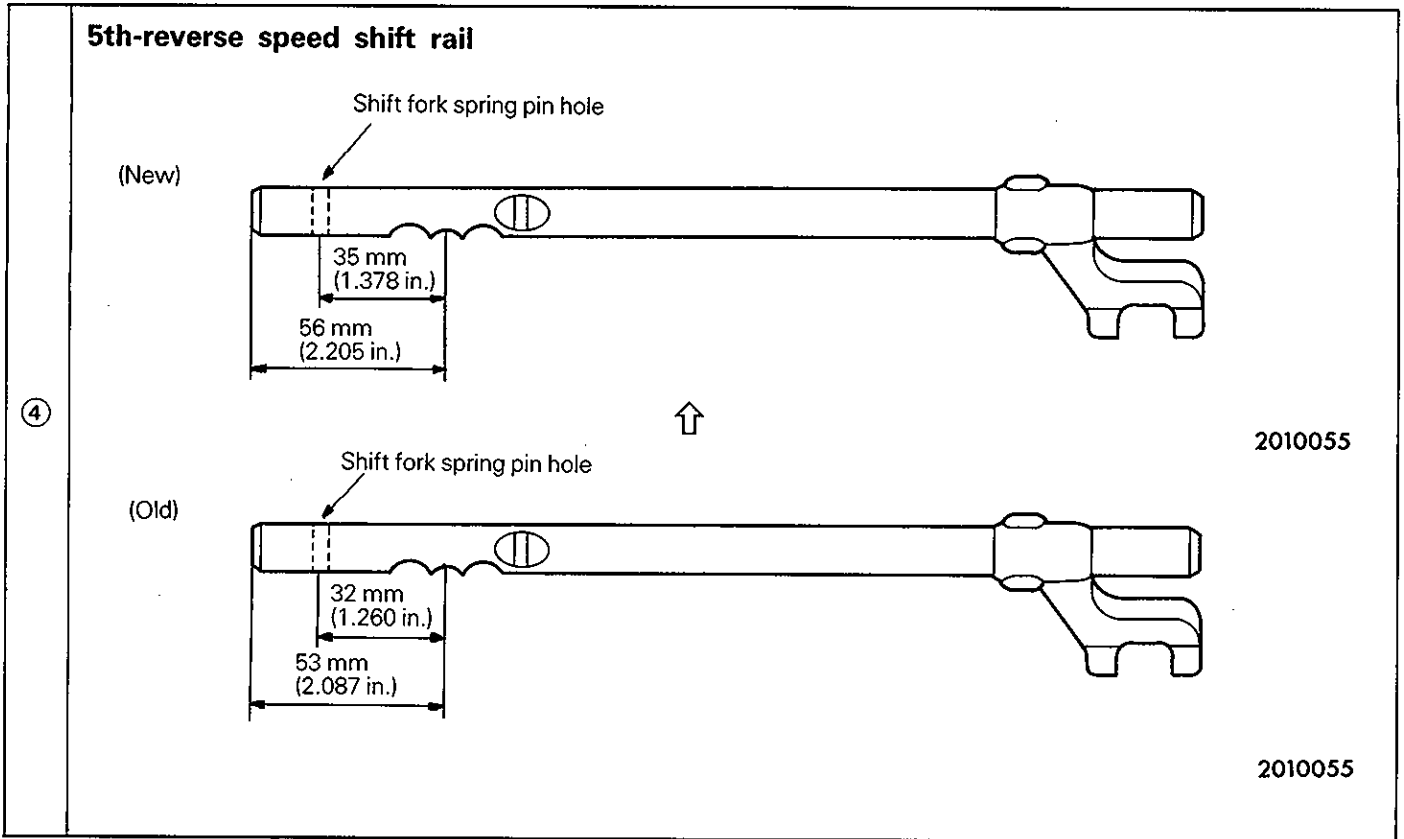

F5M31, F5M33, W5M31, W5M33

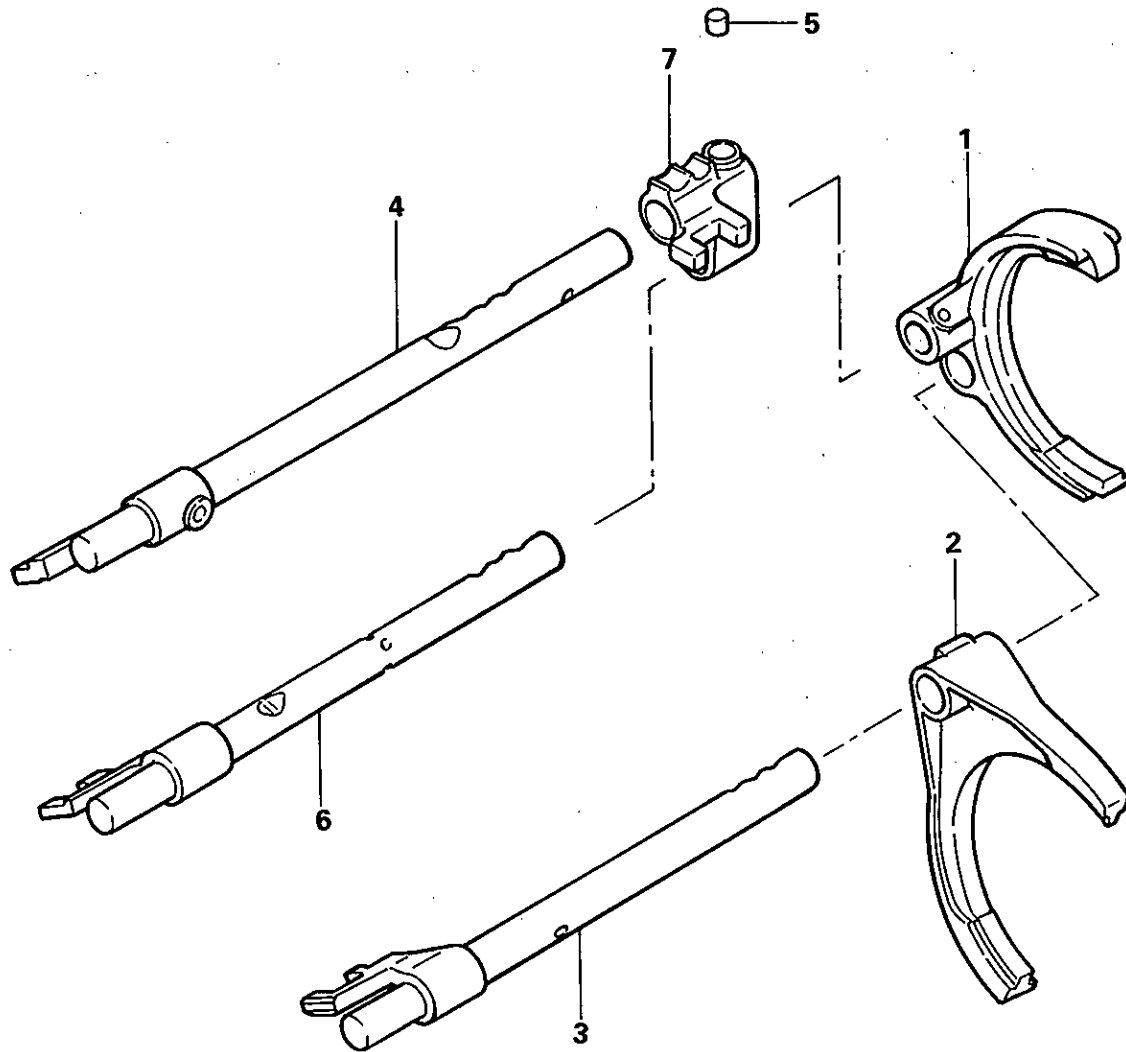

Disassembly steps

- 1. 3rd-4th speed shift fork
- 2. 1st-2nd speed shift fork
- 3. 3rd-4th speed shift rail
- 4. 5th-reverse speed shift rail
- A** 5. Interlock plunger
- 6. 3rd-4th speed shift rail
- 7. Reverse shift lug

210027

SERVICE POINTS OF REASSEMBLY

A INSTALLATION OF INTERLOCK PLUNGER

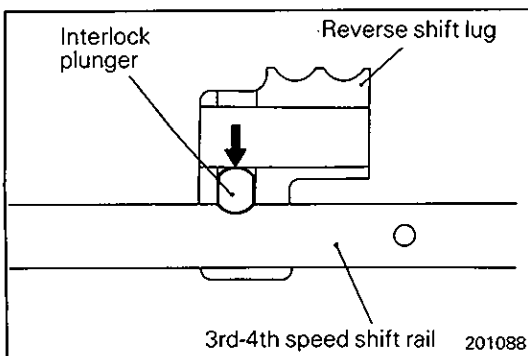

13. SPEEDOMETER DRIVEN GEAR DISASSEMBLY AND REASSEMBLY

Disassembly steps

- B** 1. O-ring
- A** 2. Spring pin
- 3. Speedometer driven gear
- 4. Oil seal
- 5. Sleeve

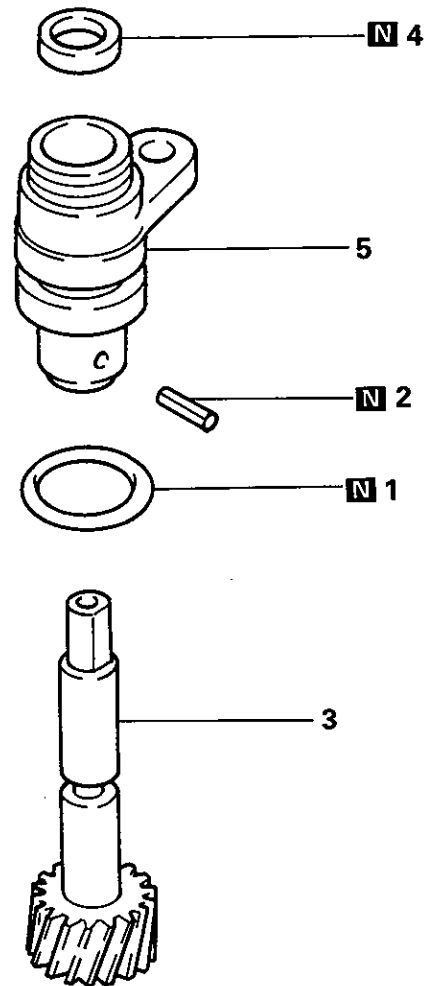

201078

SERVICE POINTS OF REASSEMBLY

A INSTALLATION OF SPEEDOMETER DRIVEN GEAR

- (1) Apply gear oil sparingly to the speedometer driven gear shaft and insert the shaft.

B INSTALLATION OF SPRING PIN

- (1) Install the spring pin in such a way that its slit does not face the gear shaft.

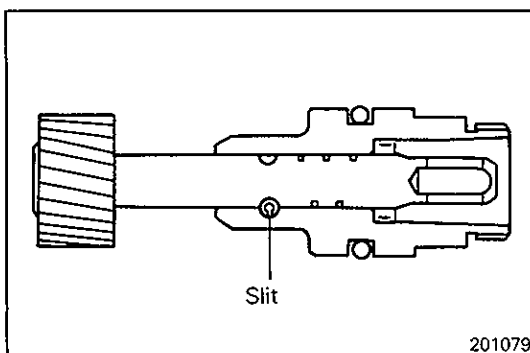

201079

NOTES

14. CLUTCH HOUSING

DISASSEMBLY AND REASSEMBLY

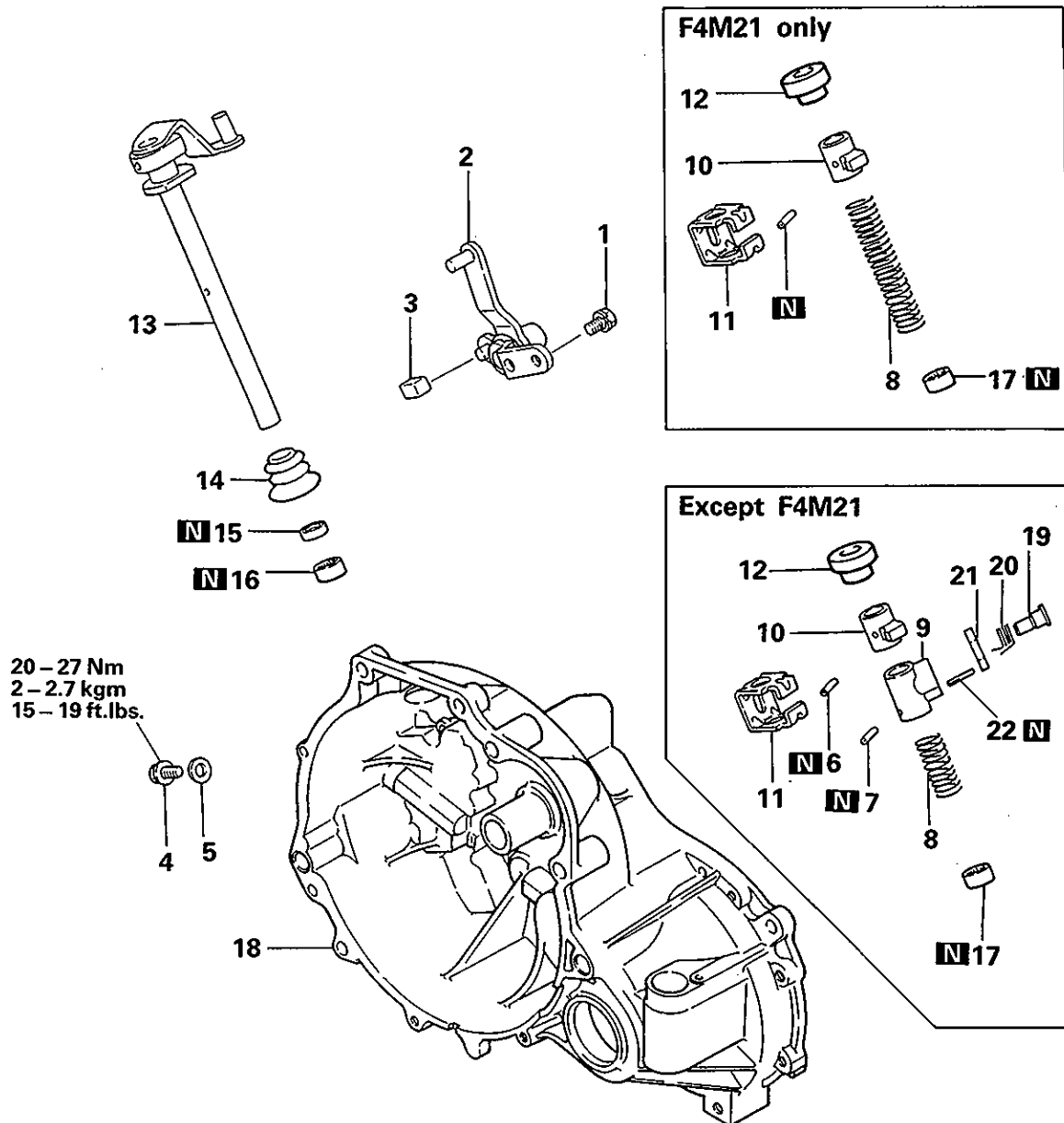

Disassembly steps

- 1. Bolt
- 2. Select lever assembly
- 3. Select lever shoe
- 4. Interlock plate bolt
- 5. Gasket
- 6. Lock pin
- 7. Spring pin
- 8. Neutral return spring
- 9. Stopper body
- 10. Control finger
- 11. Interlock plate

(A) (C)
(B) (C)

- 12. Neutral return spring assembly
- 13. Control shaft
- 14. Control shaft boot
- 15. Oil seal
- 16. Needle bearing
- 17. Needle bearing
- 18. Clutch housing
- 19. Pin
- 20. Return spring
- 21. Stopper plate
- 22. Spring pin

(C) (B) (A)
(C) (A)

SERVICE POINTS OF DISASSEMBLY**(A) REMOVAL OF LOCK PIN****Caution**

- When removing the lock pin, turn the control lever to such position that the lock pin will not contact the clutch housing.

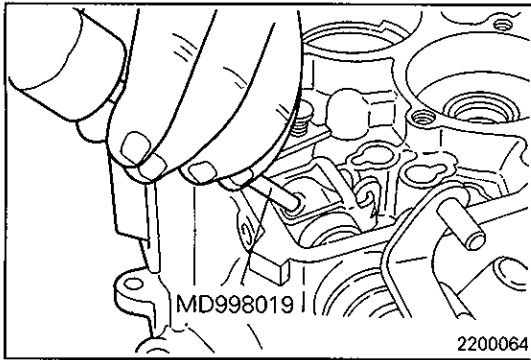
**(B) REMOVAL OF SPRING PIN****Caution**

- When removing the spring pin, pull the control shaft in the direction illustrated so that the spring pin will not contact the clutch housing.

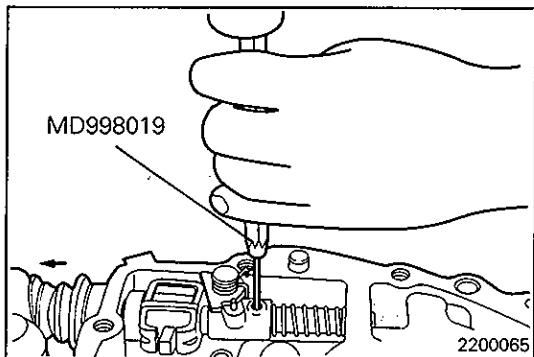
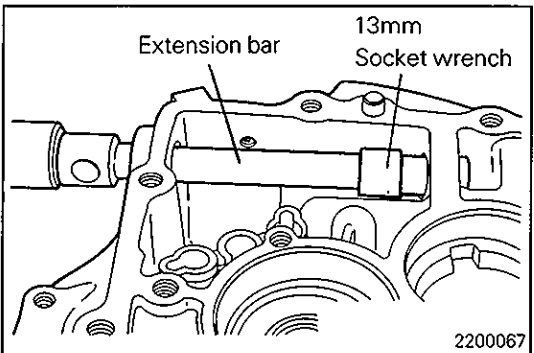
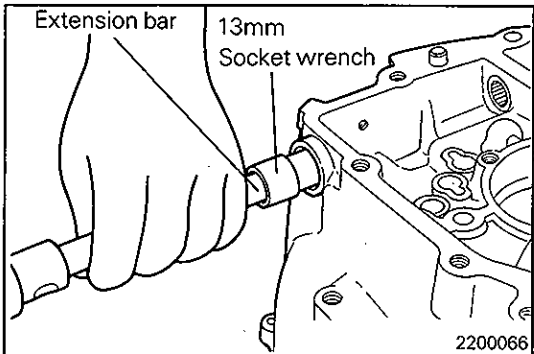
**(C) REMOVAL OF NEEDLE BEARING****SERVICE POINTS OF REASSEMBLY****(A) INSTALLATION OF NEEDLE BEARINGS**

- (1) Install the needle bearing flush with the surface A of the clutch housing using a socket wrench.
- (2) Install with the part type stamped side facing the surface A.

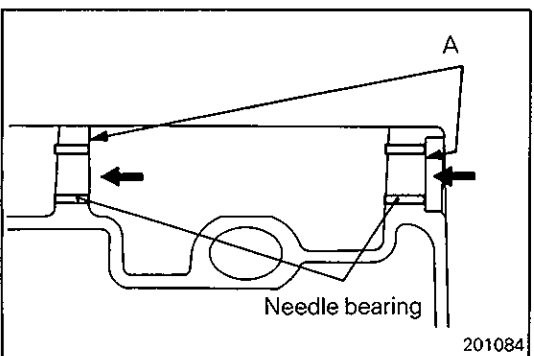

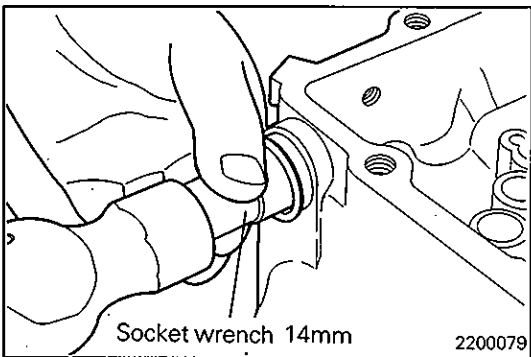
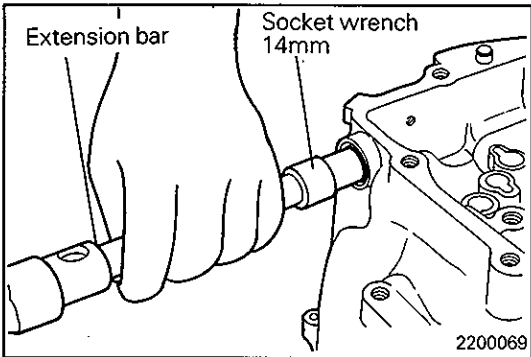
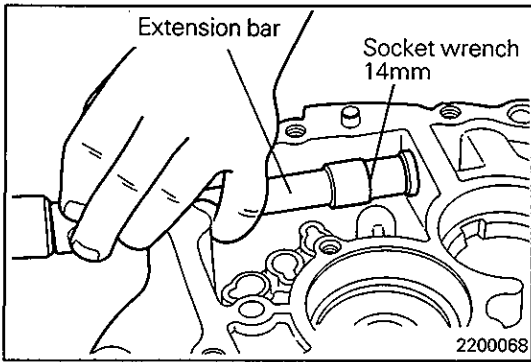

B INSTALLATION OF OIL SEAL

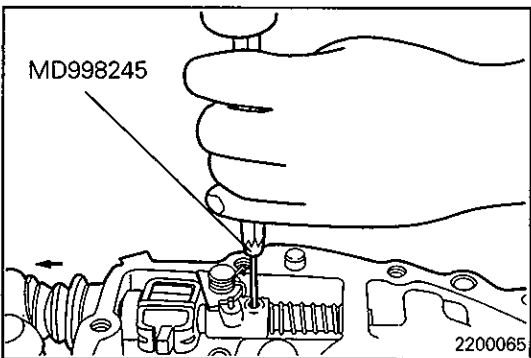

C INSTALLATION OF SPRING PIN / LOCK PIN

Caution

- Do not reuse the spring pin and lock pin.
- Install the spring pin in such a way its slit will be at right angle to the control shaft center.

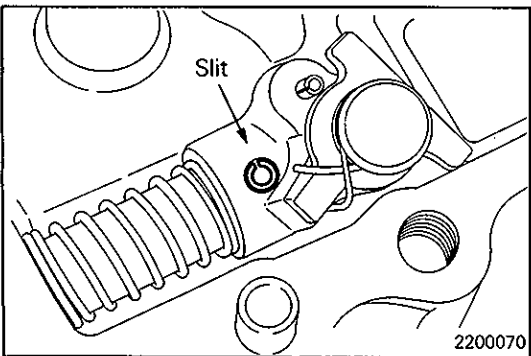

NOTES

15. TRANSFER

DISASSEMBLY AND REASSEMBLY

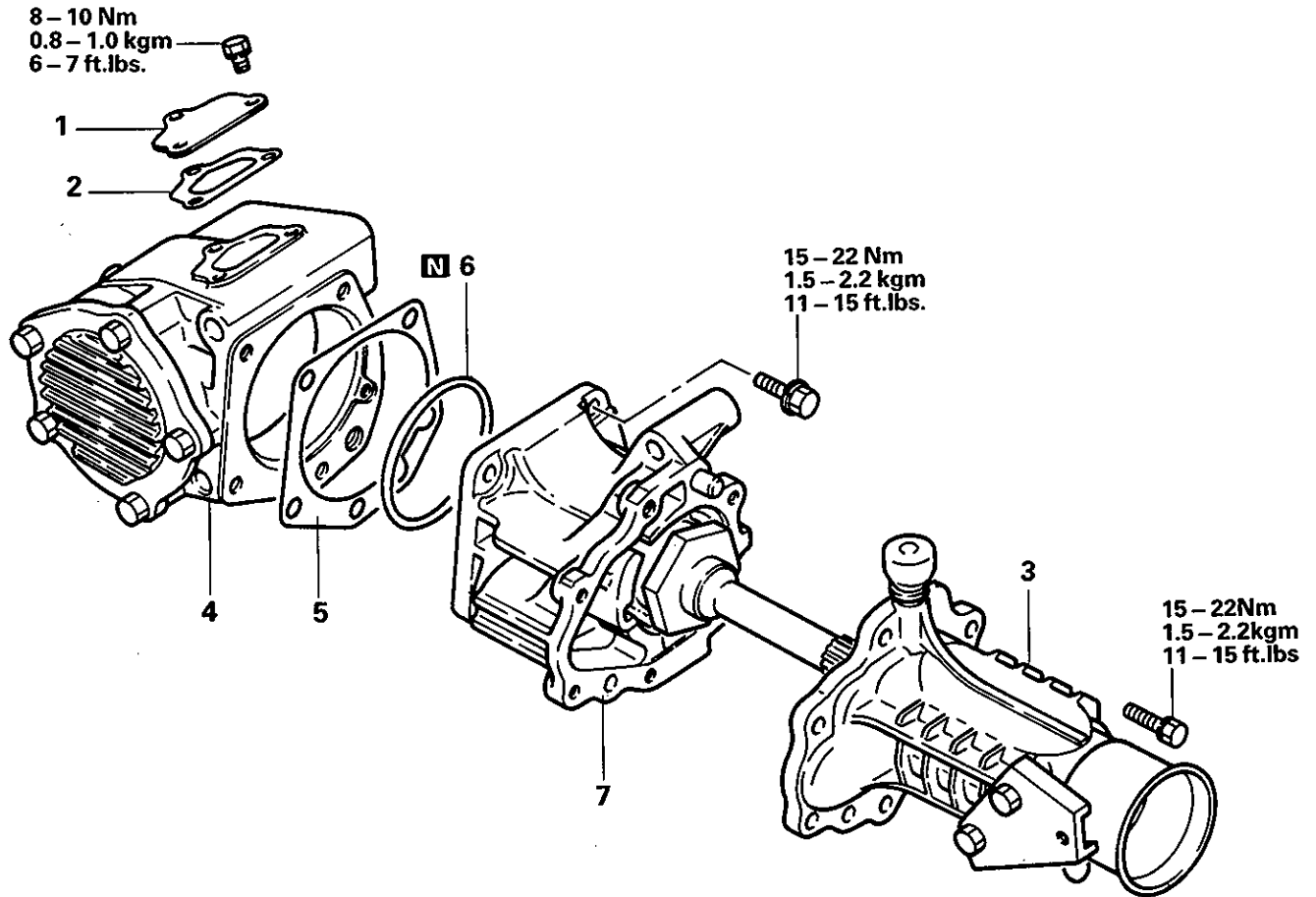

Disassembly steps

- 1. Cover
- E** 2. Cover gasket
- D** 3. Extension housing assembly
- C** 4. Transfer case sub assembly
- B** 5. Spacer
- 6. O-ring
- A** 7. Transfer case adapter sub assembly

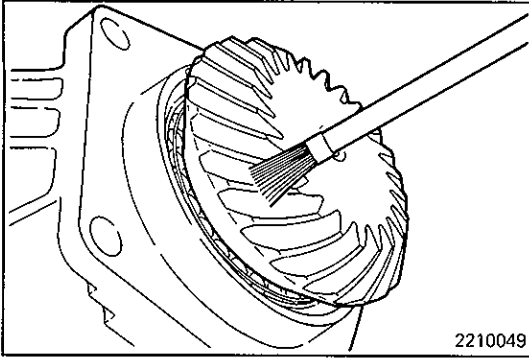

2210049

SERVICE POINTS OF REASSEMBLY

A INSTALLATION OF TRANSFER CASE ADAPTER SUB ASSEMBLY

- (1) Apply a light and uniform coat of machine blue or red lead to the driven bevel gear teeth (both sides) using a brush.

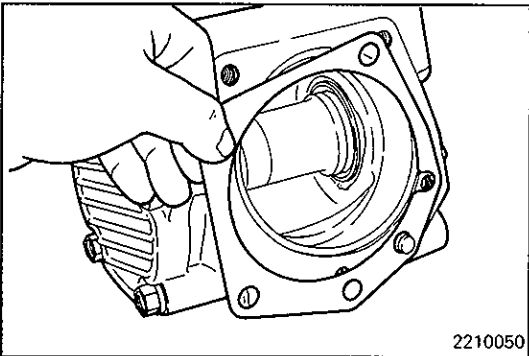

2210050

B INSTALLATION OF SPACER

- (1) Install the spacer that has been used.

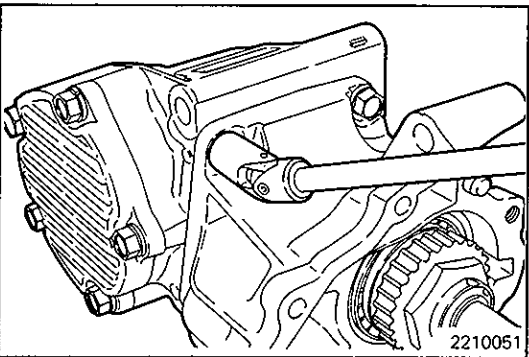

2210051

C INSTALLATION OF TRANSFER CASE SUB ASSEMBLY

- (1) Tighten the transfer case adapter sub assembly to the transfer case sub assembly to specified torque.

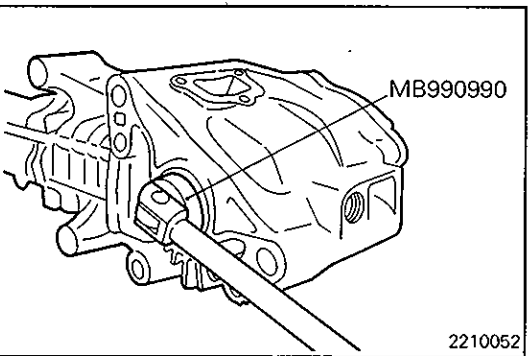

2210052

- (2) Using the special tool, turn the drive bevel gear shaft (one turn in normal direction, one turn in reverse direction).

NOTE

Do not give the drive bevel gear shaft more than one turn in either direction as this causes unclear tooth contact pattern.

- (3) Check to see if the drive bevel gear tooth contact is normal.

NOTE

Refer to the TOOTH CONTACT ADJUSTMENT PROCEDURES on next page (below) for the standard tooth contact.

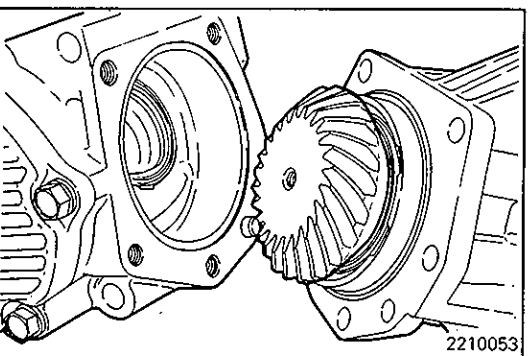

2210053

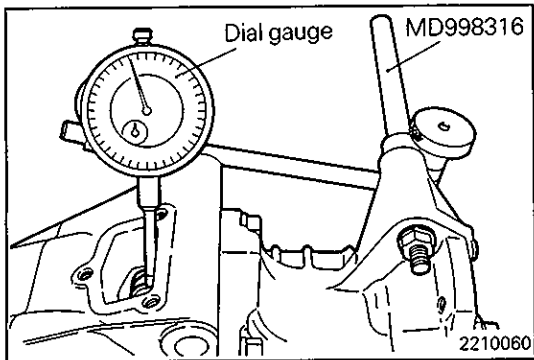

(4) Check to see if the drive bevel gear and driven bevel backlash is as specified.

Standard value: Bevel gear set backlash
0.08 – 0.13 (0.0031 – 0.0051 in.)

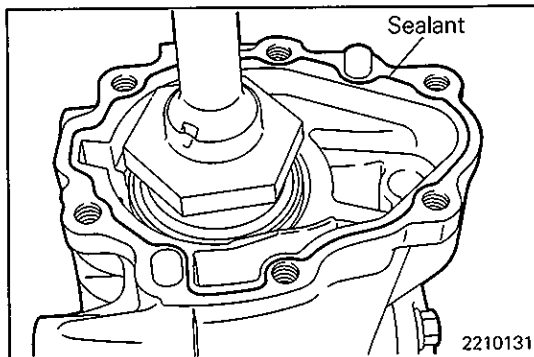

D INSTALLATION OF EXTENSION HOUSING

(1) Apply sealant to the adapter flange surface and install the extension housing.

Specified sealant:
THREEBOND TB1216 or equivalent

NOTE

Squeeze out sealant from the tube uniformly and continuously in adequate amount.

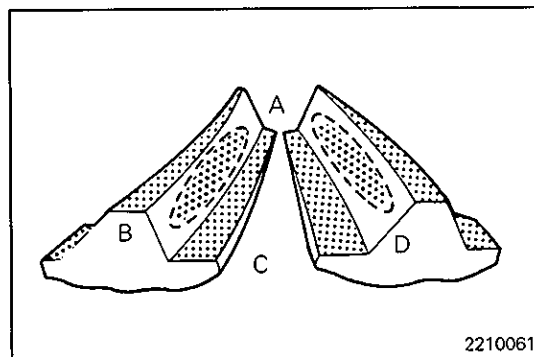

TOOTH CONTACT ADJUSTING PROCEDURES

1. Standard tooth contact pattern

- A ... Small end side
- B ... Drive side tooth face
(Side on which force acts when running forward)
- C ... Big end side
- D ... Coast side tooth face
(Side on which force acts when reversing)

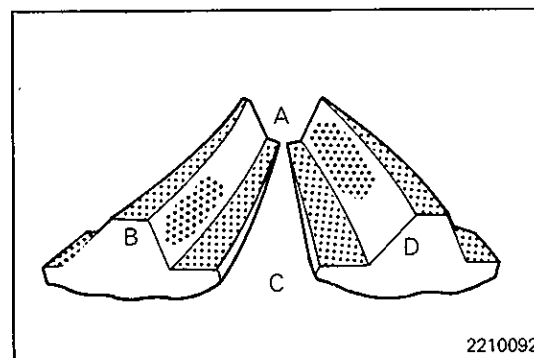

2. Tooth contact pattern produced when drive bevel gear height is too large

Cause

The driven bevel is too close to the drive bevel gear.

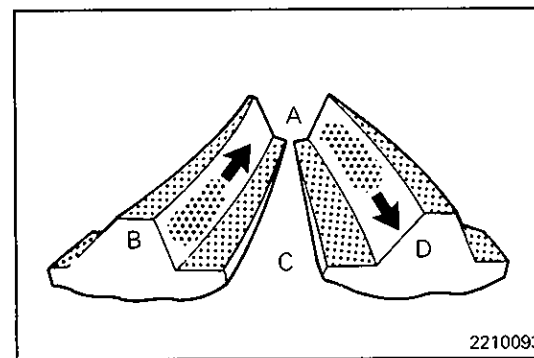

Remedy

Use thicker bevel gear mount adjusting spacer to separate the driven bevel gear more from the drive bevel gear.

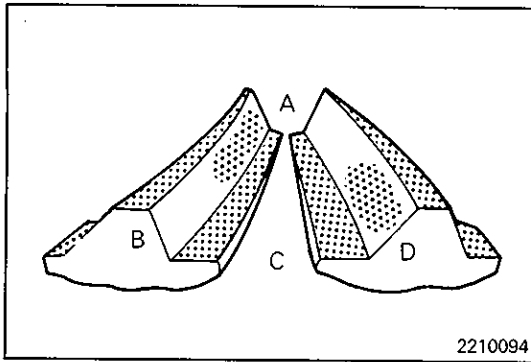

3. Tooth contact pattern produced when driven bevel gear height is too small

Cause

The driven bevel gear is too separated from the drive bevel gear.

Remedy

Use thinner driven bevel gear mount adjusting spacer to bring the driven bevel gear more closer to the drive bevel gear.

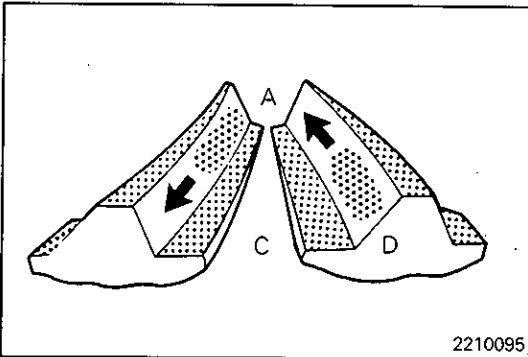

NOTE

(1) If correct tooth contact cannot be obtained even by change of the driven bevel gear mount adjusting spacer, increase or decrease the drive bevel gear preload adjusting spacer and the drive bevel gear mount adjusting spacer as described below and then adjust tooth contact again.

- When the driven bevel gear height is too small even if the thinnest driven bevel gear mount adjusting spacer 0.13 mm (0.0051 in.) is used:

Replace the drive bevel gear mount adjusting spacer that is in use with one that is one rank thicker and replace the drive bevel preload adjusting spacer that is in use with one that is one rank thinner.

- When the driven bevel gear height is too large even if the thickest driven bevel gear mount adjusting spacer 0.52 mm (0.025 in.) is used:

Replace the drive bevel gear mount adjusting spacer that is in use with one that is one rank thinner and replace the drive bevel gear preload adjusting spacer that is in use with one that is one rank thicker.

Repeat above steps until the tooth contact pattern equal or close to the standard pattern is obtained.

- (2) If the tooth contact pattern cannot be adjusted close to the standard pattern by above adjustment, replace the drive bevel gear and driven bevel gear as a set and readjust the tooth contact.

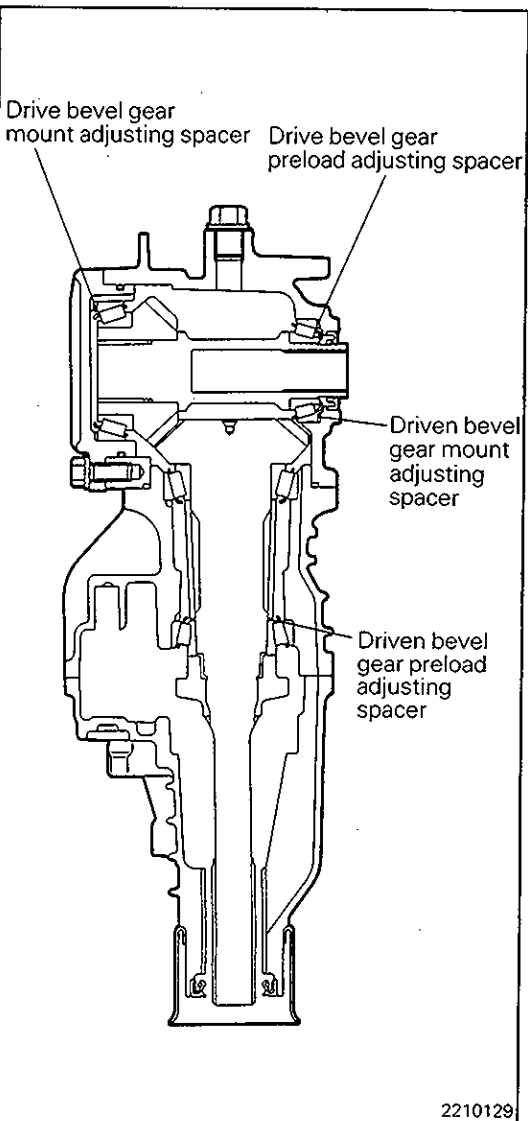

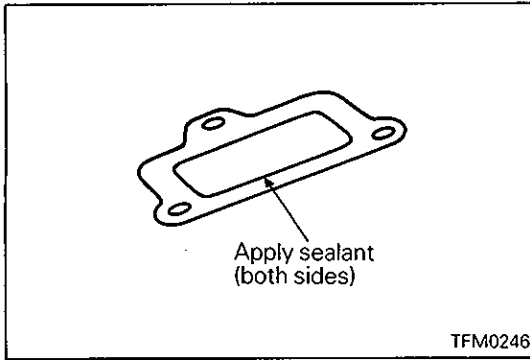

E APPLICATION OF SEALANT TO COVER GASKET

Specified sealant:

3M ATD Part No. 8660 or equivalent

NOTES

16. EXTENSION HOUSING DISASSEMBLY AND REASSEMBLY

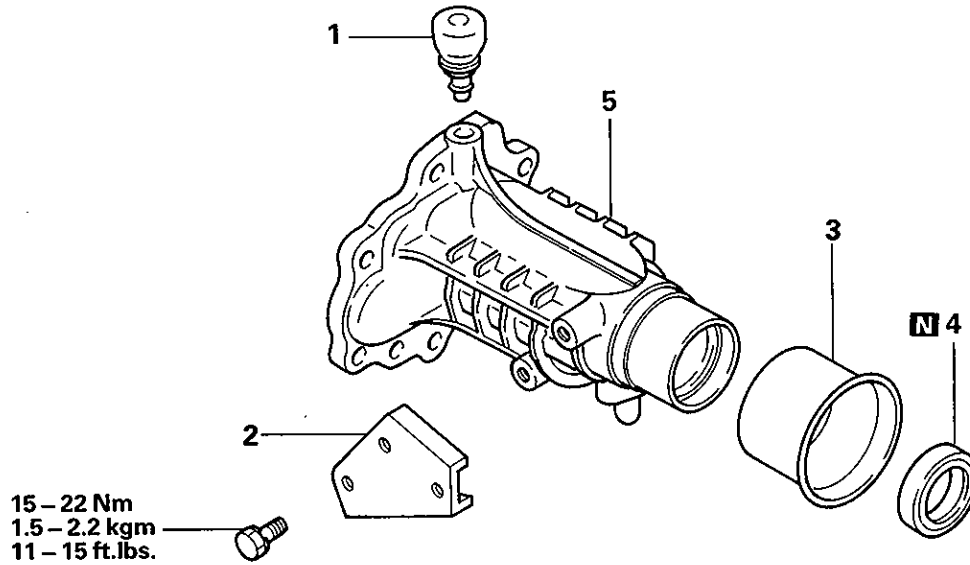

Disassembly steps

- B** 1. Air bleeder
- 2. Hanger bracket (with differential lock only)
- 3. Dust seal guard
- A** 4. Oil seal
- 5. Extension housing

2210132

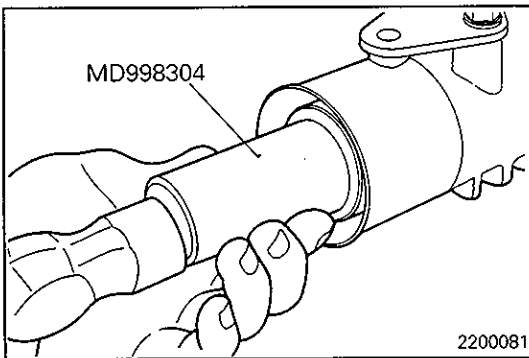

SERVICE POINTS OF REASSEMBLY

A INSTALLATION OF OIL SEAL

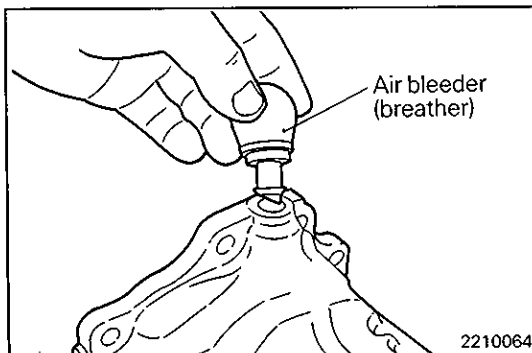

B INSTALLATION OF AIR BLEEDER

- (1) Install the air bleeder applying sealant to the inserting portion.

Specified sealant:

3M SUPER WETHERSTRIP No. 8001 or equivalent

NOTES

**17. TRANSFER CASE
DISASSEMBLY AND REASSEMBLY**

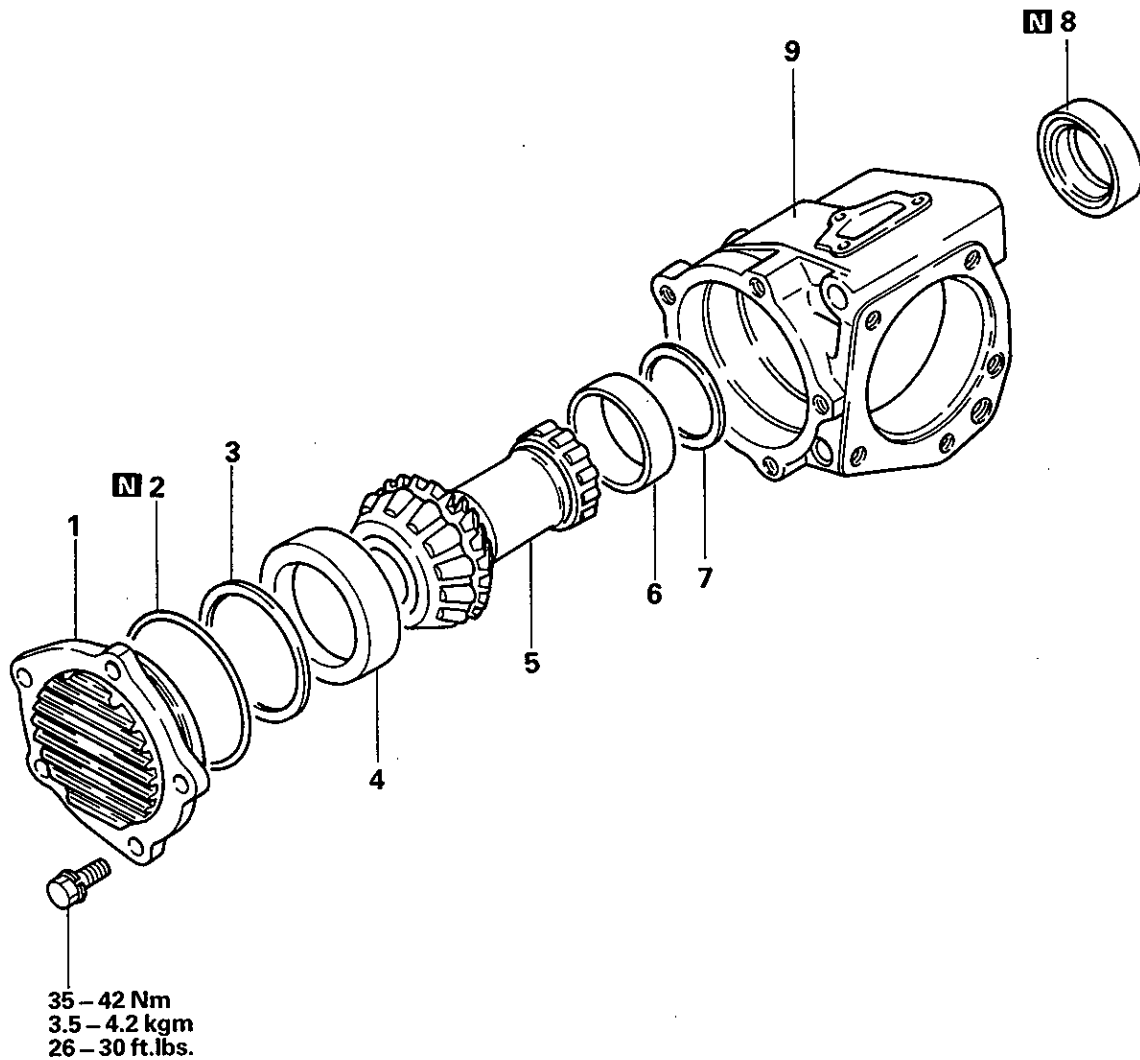

Disassembly steps

1. Transfer cover
2. O-ring
- B** 3. Spacer
4. Outer race
5. Drive bevel gear assembly
6. Outer race
- B** 7. Spacer
- A** 8. Oil seal
9. Transfer case

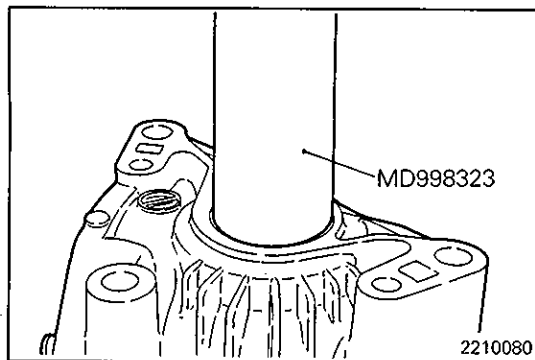
SERVICE POINTS OF REASSEMBLY**A** INSTALLATION OF OIL SEAL**B** SELECTION OF SPACER

- (1) Use the existing spacer to assemble the transfer case.
- (2) Using the special tool, check that the bevel gear rotating drive torque is within standard range.

Standard value:

1.7 – 2.5 Nm

(0.17 – 0.25 kgm, 1.23 – 1.81 ft.lbs.)

- (3) If the rotating drive torque is outside of the standard range, adjust using adjusting spacers.

NOTE

For adjustment, use two spacers of which thickness is as close as possible to each other.

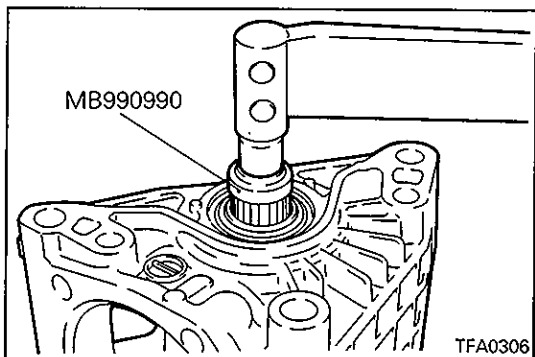

18. TRANSFER CASE ADAPTER

DISASSEMBLY AND REASSEMBLY

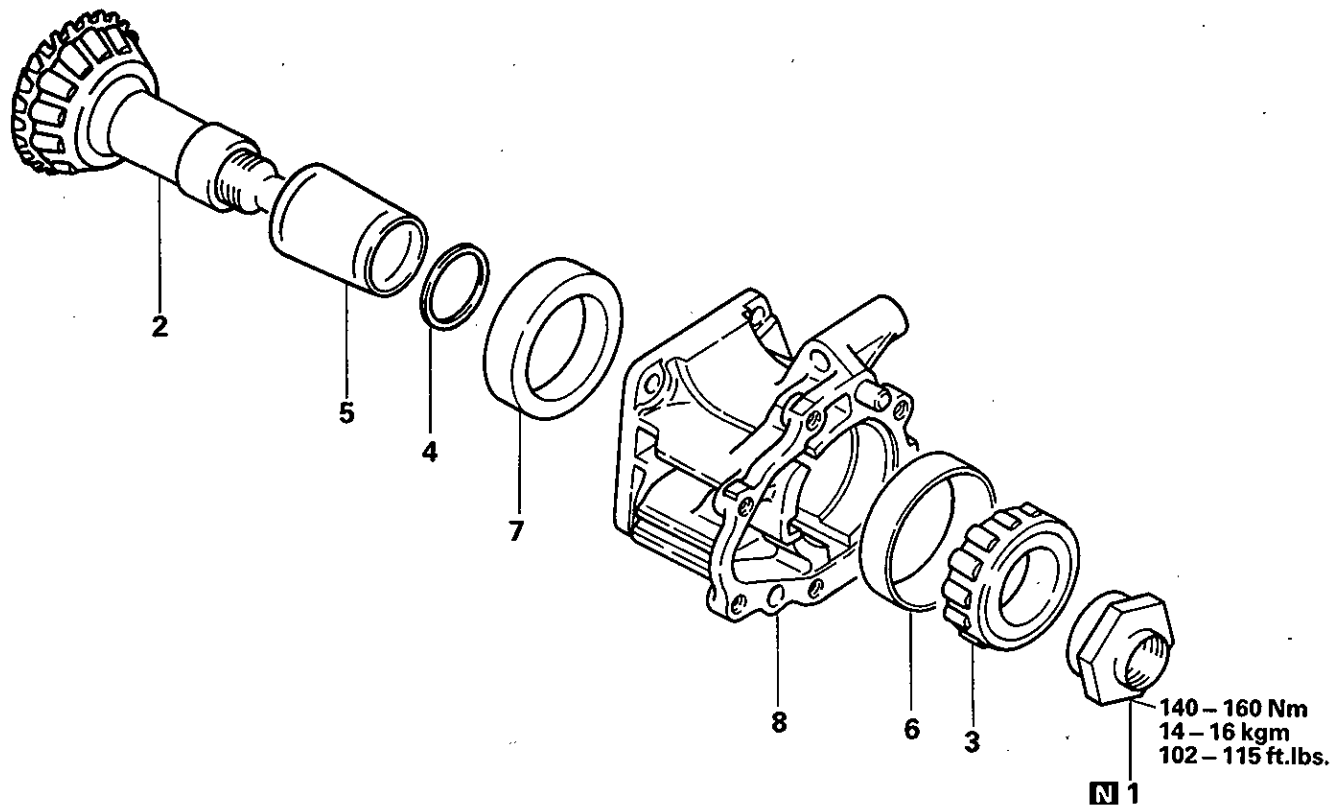

Disassembly steps

- Ⓐ Ⓒ 1. Lock nut
- Ⓑ 2. Driven bevel gear assembly
- Ⓑ Ⓑ 3. Taper roller bearing
- Ⓐ 4. Spacer
- 5. Collar
- Ⓒ 6. Outer race
- Ⓒ 7. Outer race
- 8. Transfer case assembly

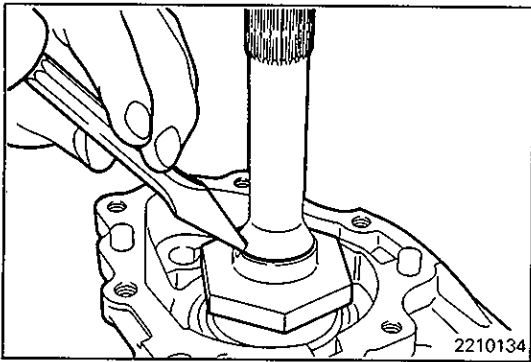
**SERVICE POINTS OF DISASSEMBLY****Ⓐ REMOVAL OF LOCKNUT**

(1) Unlock the lock nut. (Straighten the bent nut.)

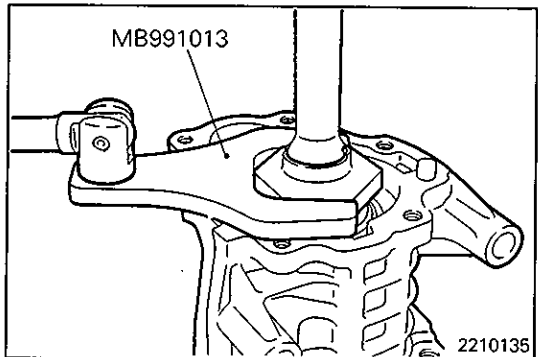

(2) Holding the driven bevel gear in a vice and using the special tool, remove the lock nut.

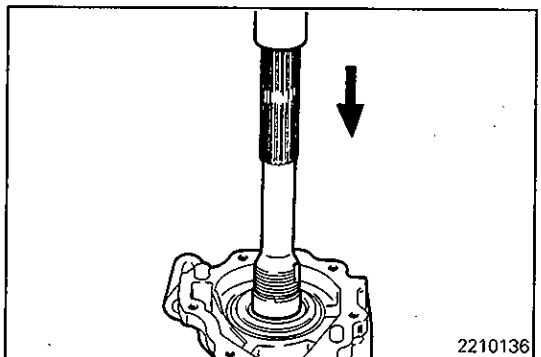
**Ⓑ REMOVAL OF DRIVEN BEVEL GEAR ASSEMBLY**

(1) Using a press, remove the driven bevel gear assembly.

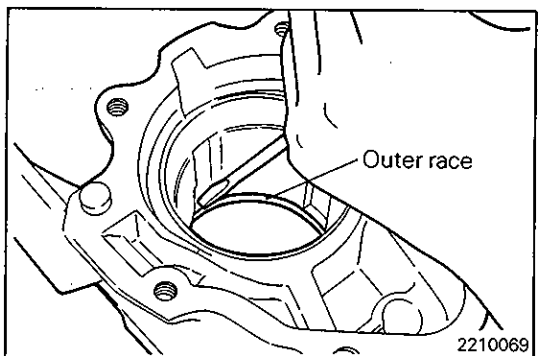
**Ⓒ REMOVAL OF OUTER RACE**

(1) Remove the outer race, striking lightly with a screwdriver, etc.

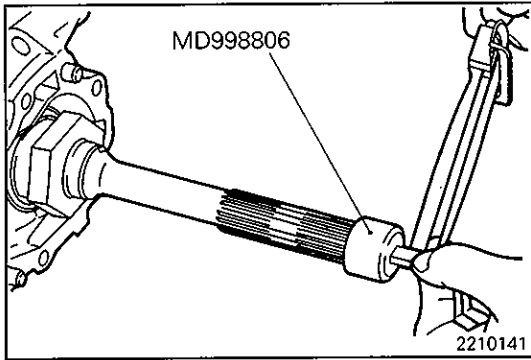

SERVICE POINTS OF REASSEMBLY

A SELECTION OF SPACER

- (1) Use the existing spacer to assemble the transfer case adapter.
- (2) Using the special tool, check that the bevel gear rotating drive torque is within standard range.

Standard value:

1.0 – 1.7 Nm

(0.10 – 0.17 kgm, 0.72 – 1.23 ft.lbs.)

- (3) If the rotating drive torque is outside of the standard range, adjust using adjusting spacers.

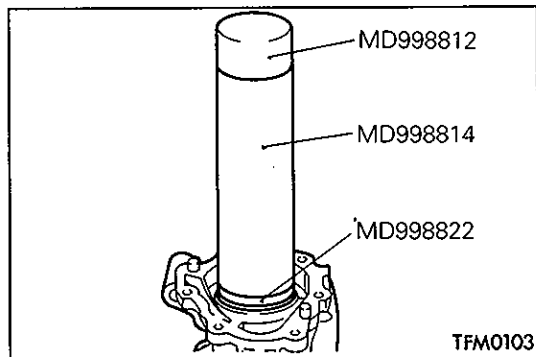

B INSTALLATION OF TAPER ROLLER BEARING

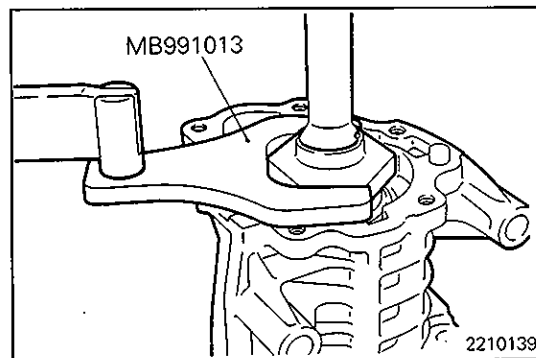

C INSTALLATION OF LOCK NUT

- (1) Holding the driven bevel gear in a vice and using the special tool, tighten the lock nut to specified torque.

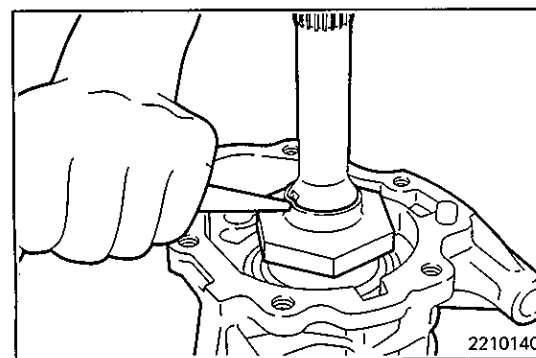

- (2) Lock the lock nut at two positions.

NOTES

19. DRIVE BEVEL GEAR DISASSEMBLY AND REASSEMBLY

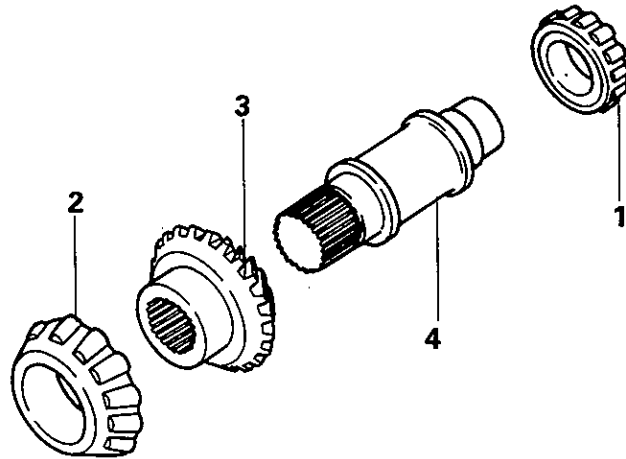

Disassembly steps

- Ⓐ Ⓐ 1. Taper roller bearing
- Ⓐ Ⓐ 2. Taper roller bearing
- Ⓑ 3. Drive bevel gear
- 4. Drive bevel gear shaft

2210142

SERVICE POINTS OF DISASSEMBLY

Ⓐ REMOVAL OF TAPER ROLLER BEARING

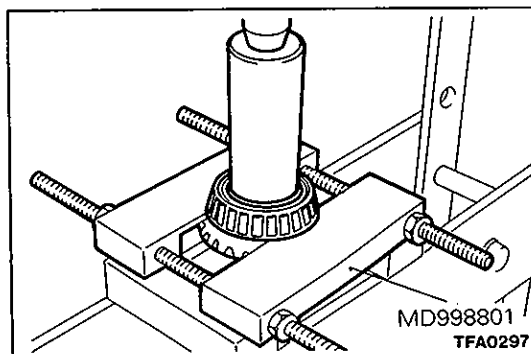
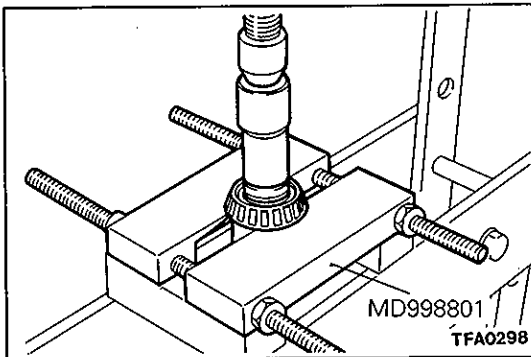

Ⓑ REMOVAL OF DRIVE BEVEL GEAR

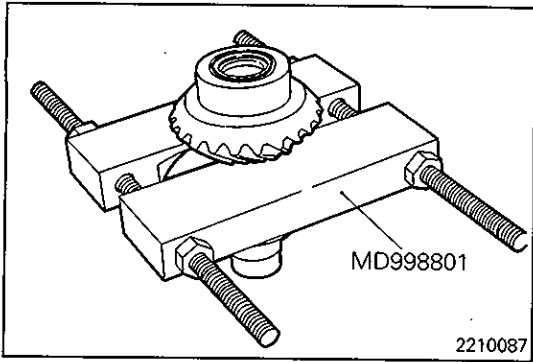

SERVICE POINTS OF REASSEMBLY

Ⓐ INSTALLATION OF TAPER ROLLER BEARING

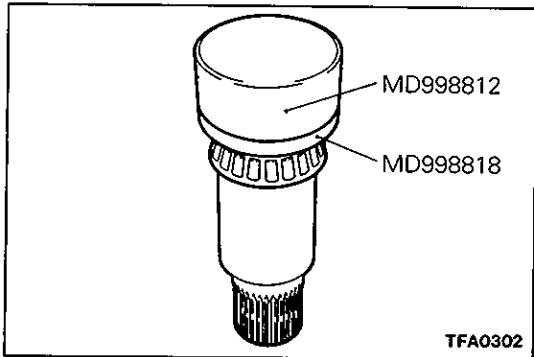
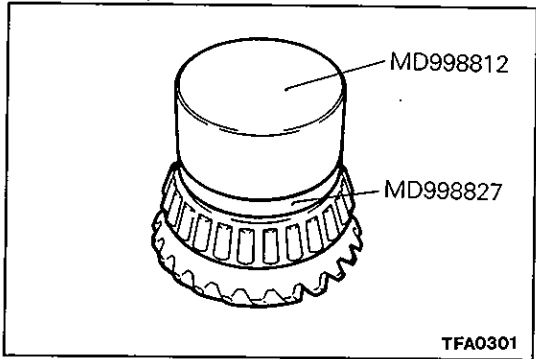

20. DRIVEN BEVEL GEAR DISASSEMBLY AND REASSEMBLY

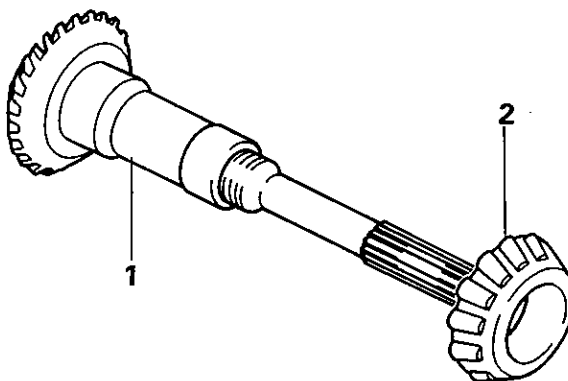

Disassembly steps

- Ⓐ **A** 1. Taper roller bearing
- 2. Drive bevel gear

2210143

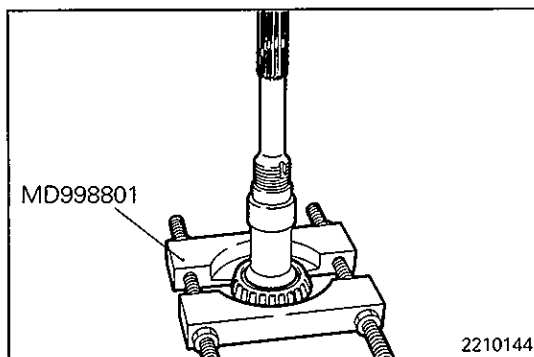

SERVICE POINTS OF DISASSEMBLY

- Ⓐ REMOVAL OF TAPER ROLLER BEARING

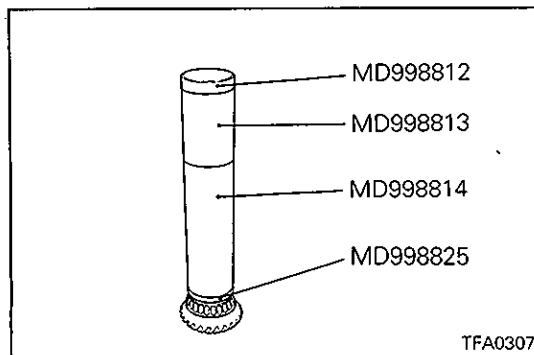

SERVICE POINTS OF REASSEMBLY

- A** INSTALLATION OF TAPER ROLLER BEARING

NOTES