

AUTOMATIC TRANSMISSION

F4A33, W4A32, W4A33

CONTENTS

GENERAL INFORMATION	23B- 0- 3
1. SPECIFICATIONS	23B- 1- 1
TRANSMISSION MODEL TABLE	23B- 1- 1
GEAR RATIO TABLE	23B- 1-1a
SERVICE SPECIFICATIONS	23B- 1- 2
VALVE BODY SPRING IDENTIFICATION	23B- 1- 2
ADJUSTING PRESSURE PLATE, SNAP RINGS AND SPACERS	23B- 1- 3
TORQUE SPECIFICATIONS	23B- 1- 9
2. SPECIAL TOOLS	23B- 2- 1
3. TRANSMISSION (F4A33)	23B- 3- 1
4. TRANSMISSION (W4A32, W4A33)	23B- 4- 1
5. OIL PUMP	23B- 5- 1
6. FRONT CLUTCH	23B- 6- 1
7. REAR CLUTCH	23B- 7- 1
8. END CLUTCH	23B- 8- 1
9. PLANETARY GEAR	23B- 9- 1
10. ANNULUS GEAR AND TRANSFER DRIVE GEAR SET	23B-10- 1
11. DIFFERENTIAL	23B-11- 1
12. KICKDOWN SERVO	23B-12- 1
13. LOW-REVERSE BRAKE	23B-13- 1
14. SPEEDOMETER GEAR	23B-14- 1
15. VALVE BODY	23B-15- 1
16. TRANSFER SHAFT (F4A33)	23B-16- 1
17. CENTRAL DIFFERENTIAL (W4A32, W4A33)	23B-17- 1
18. FRONT OUTPUT SHAFT (W4A32, W4A33)	23B-18- 1
19. TRANSFER (W4A32, W4A33)	23B-19- 1
20. TRANSFER CASE ADAPTER (W4A32, W4A33)	23B-20- 1
21. TRANSFER CASE (W4A32, W4A33)	23B-21- 1
22. EXTENSION HOUSING (W4A32, W4A33)	23B-22- 1
23. 4-WHEEL STEERING OIL PUMP DRIVE GEAR	23B-23- 1

GENERAL INFORMATION

SECTIONAL VIEW – F4A33 <Up to MODEL 1992>

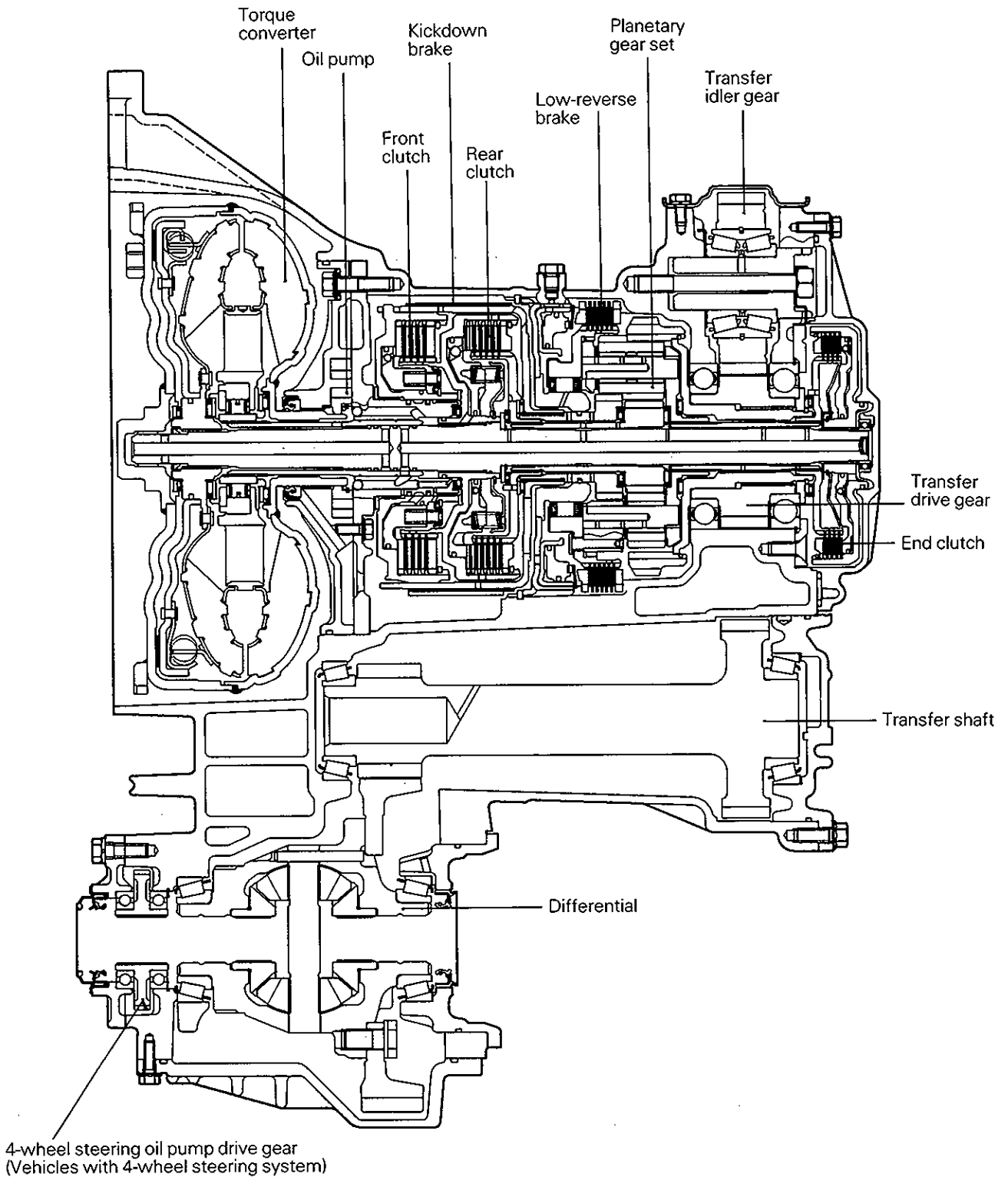

SECTIONAL VIEW – F4A33 <MODEL 1993>

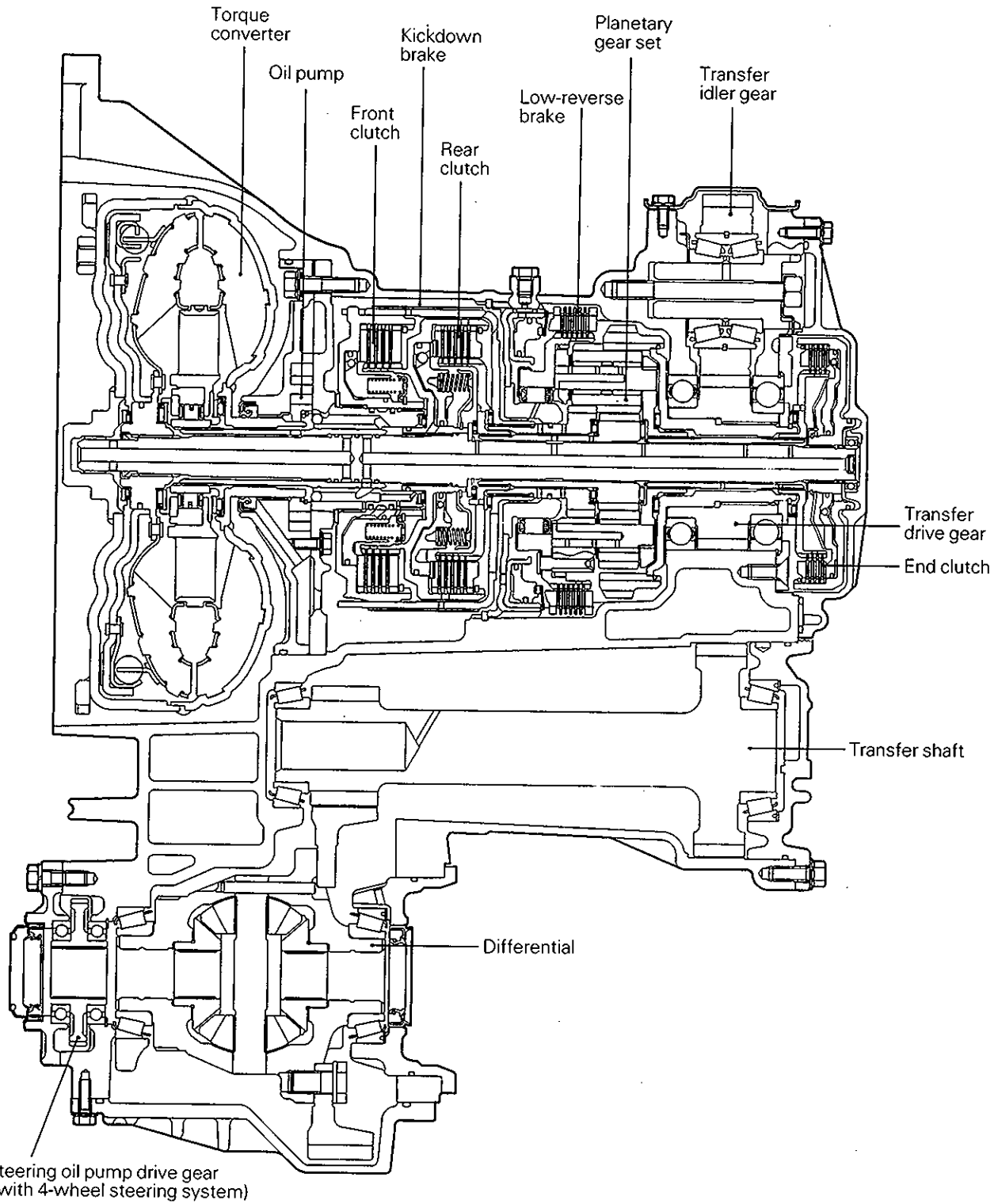

Intentionally blank

SECTIONAL VIEW – W4A32

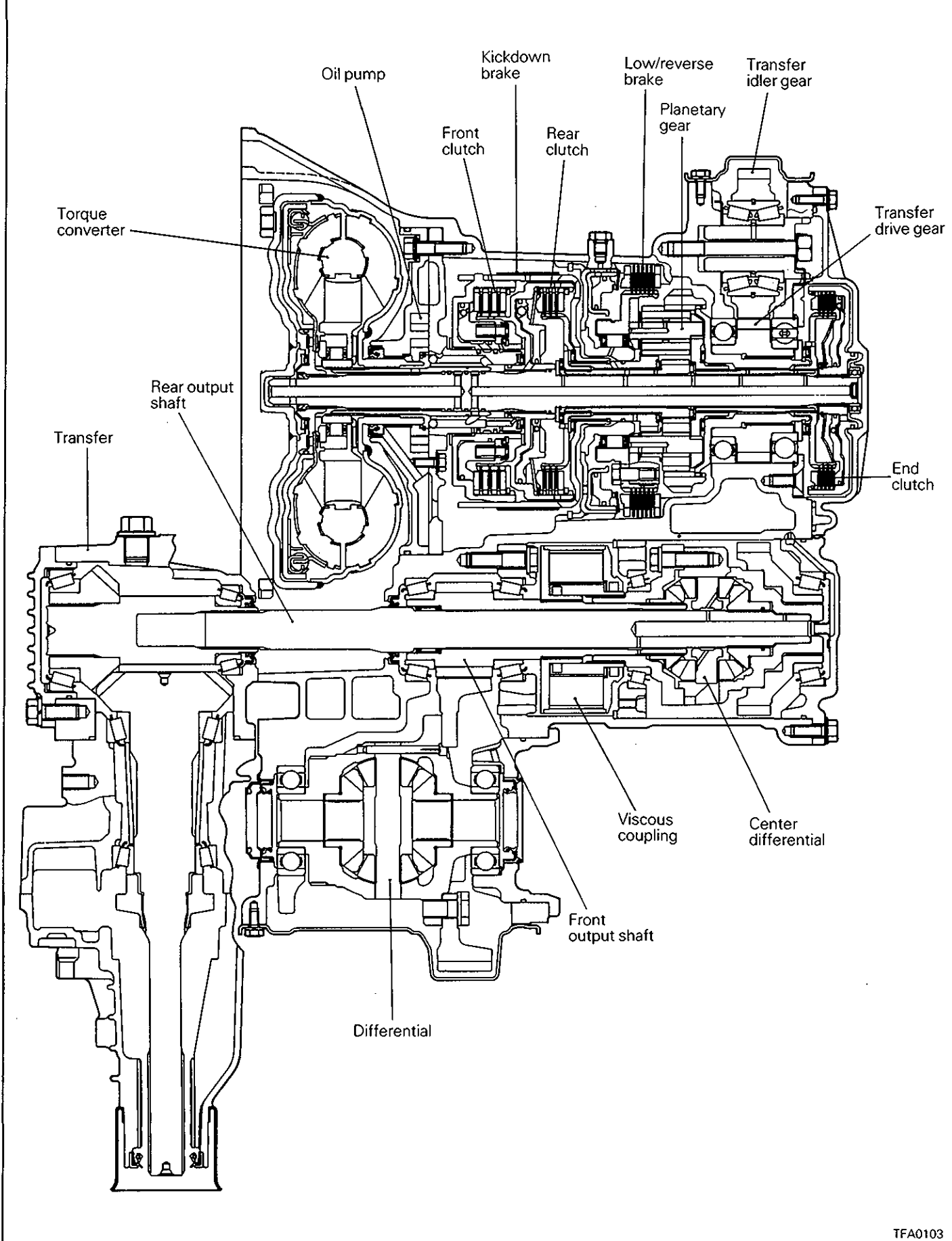

SECTIONAL VIEW – W4A33 <UP TO MODEL 1992>

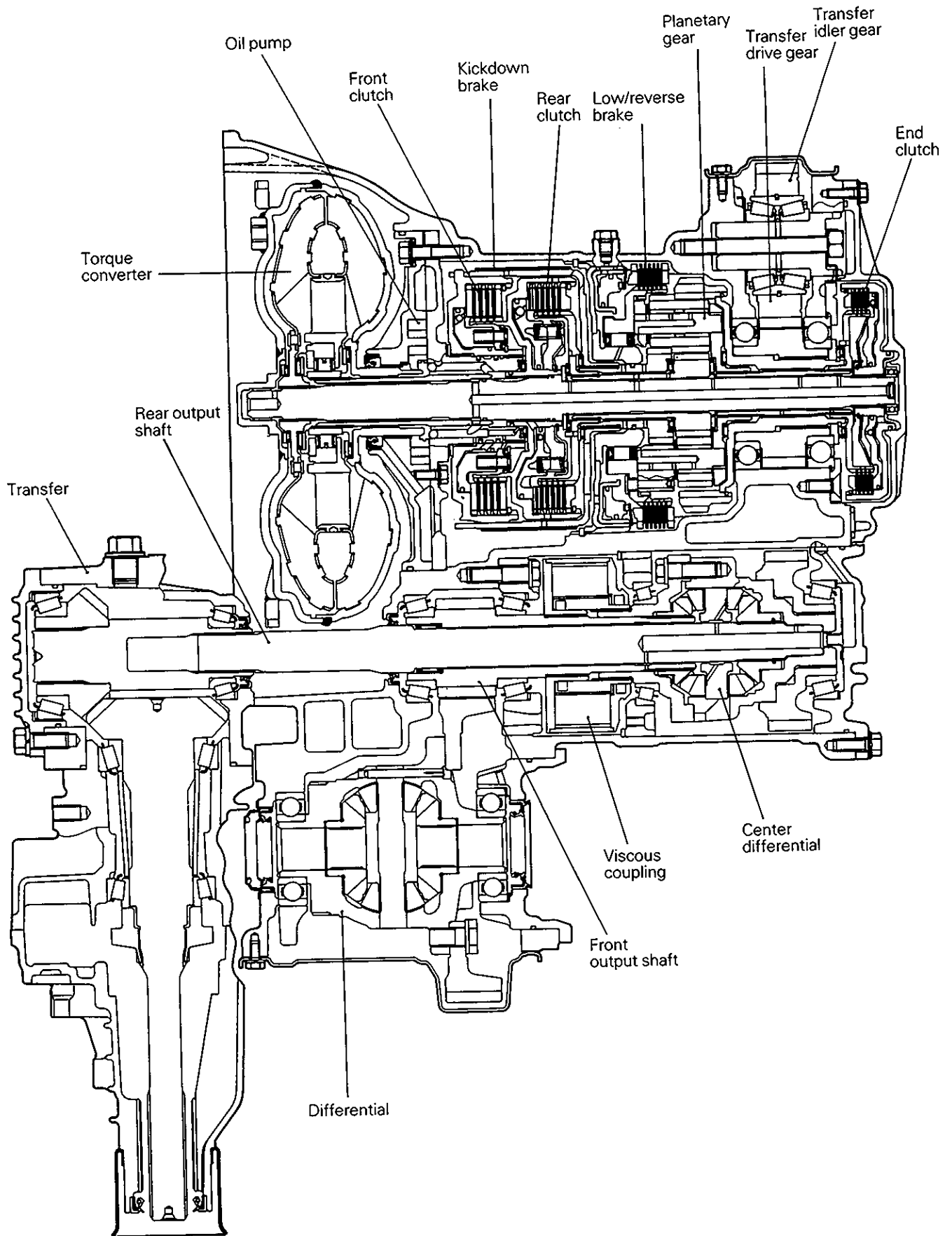

SECTIONAL VIEW – W4A33 <MODEL 1993>

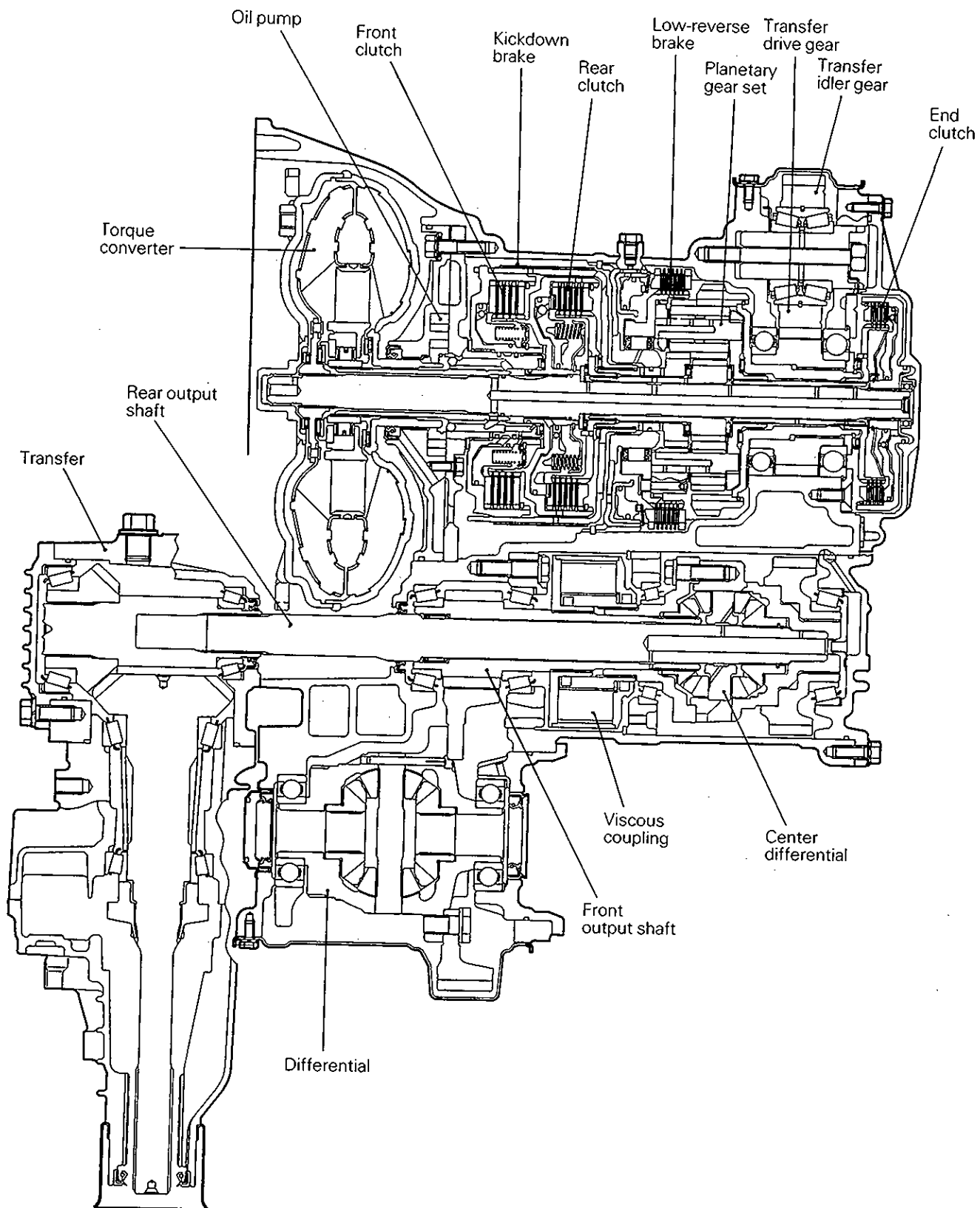

HYDRAULIC CONTROL SYSTEM

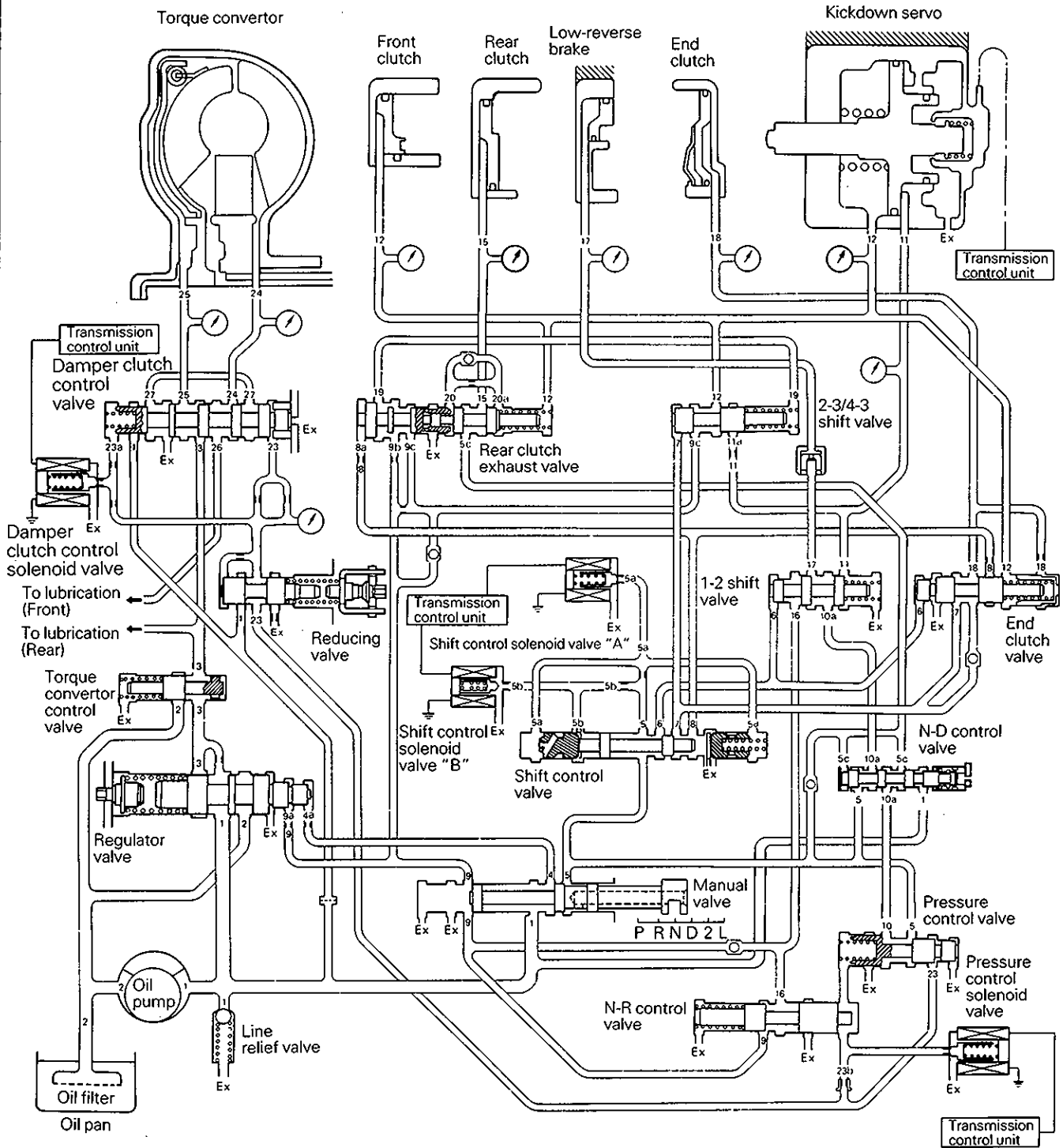

LIST OF MAJOR CHANGES

Description of Change	Applicable Transmission Model	Effective Date
① Change of drive plate tightening bolt	F4A33	From 1992 model

NOTES

1. SPECIFICATIONS**TRANSMISSION MODEL TABLE – MODEL 1991**

Transmission model	Gear ratio	Speedometer gear ratio	Final gear ratio	Vehicle model	Engine model
EC F4A33-1-UNN3	A	28/36	4.376	F16A	6G72
UNN4	A	28/36	4.376	F16A	6G72 DOHC
UNN5*	A	28/36	4.376	F16A	6G72 DOHC
EXP F4A33-1-MNN3	A	28/36	3.958	F16A	6G72
MNN4	A	28/36	3.958	F16A	6G72 DOHC

TRANSMISSION MODEL TABLE – MODEL 1992

Transmission model	Gear ratio	Speedometer gear ratio	Final gear ratio	Vehicle model	Engine model
EC F4A33-1-UNP3	A	28/36	4.376	F16A	6G72
UNP4	A	28/36	4.376	F16A	6G72 DOHC
UNP5*	A	28/36	4.376	F16A	6G72 DOHC
W4A32-1-WPA	B	29/36	4.750	N31W	4G93
EXP F4A33-1-MNP3	A	28/36	3.958	F16A	6G72
MNP4	A	28/36	3.958	F16A	6G72 DOHC
MNP5*	A	28/36	3.958	F16A	6G72 DOHC
W4A33-1-WNN3	A	28/36	4.750	F26A	6G72 DOHC

TRANSMISSION MODEL TABLE – MODEL 1993

Transmission model	Gear ratio	Speedometer gear ratio	Final gear ratio	Vehicle model	Engine model
EC F4A33-1-UNQ5	A	28/36	4.376	F16A	6G72-DOHC
F4A33-1-UNQ6*	A	28/36	4.376	F16A	6G72-DOHC
F4A33-1-UNQ7	A	28/36	4.376	F16A	6G72
W4A32-1-WPF	B	29/36	4.750	N43W	4G63
EXP F4A33-1-MNPC	A	28/36	3.958	F16A	6G72-DOHC
F4A33-1-MNPE*	A	28/36	3.958	F16A	6G72-DOHC
F4A33-1-MNP9	A	28/36	3.958	F16A	6G72
W4A33-1-WNQ1	A	28/36	4.750	F26A	6G72-DOHC

NOTE

DOHC: Double overhead camshaft

*: Model with 4-wheel steering

TRANSMISSION MODEL TABLE – MODEL 1994

	Transmission model	Gear ratio	Speedometer gear ratio	Final gear ratio	Vehicle model	Engine model
EC	F4A32-1-WPF	B	29/36	4.750	N43W	4G63
EXP	F4A33-1-MNQ3	A	28/36	3.958	F16A	6G72
	F4A33-1-MNQ4	A	28/36	3.958	F16A	6G72-DOHC
	F4A33-1-MNQ5*	A	28/36	3.958	F16A	6G72-DOHC
	F4A33-1-WNQ1	A	28/36	4.750	F26A	6G72-DOHC

TRANSMISSION MODEL TABLE – MODEL 1995

	Transmission model	Gear ratio	Speedometer gear ratio	Final gear ratio	Vehicle model	Engine model
EC	F4A33-1-UNQ5	A	28/36	4.367	F16A	6G72-DOHC
	F4A33-1-UNQ6	A	28/36	4.367	F16A	6G72-DOHC
	F4A33-1-UNQ7	A	28/36	4.367	F16A	6G72
	W4A32-1-LPF	B	29/36	4.668	N43W	4G63
EXP	F4A33-1-MNQ3	A	28/36	3.598	F16A	6G72
	F4A33-1-MNQ4	A	28/36	3.598	F16A	6G72-DOHC
	F4A33-1-MNQ5*	A	28/36	3.598	F16A	6G72-DOHC
	F4A33-1-MNQ8	A	28/36	3.598	F16A	6G72

TRANSMISSION MODEL TABLE – MODEL 1996

	Transmission model	Gear ratio	Speedometer gear ratio	Final gear ratio	Vehicle model	Engine model
EC	W4A32-1-LPF	B	29/36	4.668	N43W	4G63
EXP	F4A33-1-MNQ3	A	28/36	3.598	F16A	6G72
	F4A33-1-MNQ4	A	28/36	3.598	F16A	6G72-DOHC
	F4A33-1-MNQ5*	A	28/36	3.598	F16A	6G72-DOHC
	F4A33-1-MNQ8	A	28/36	3.598	F16A	6G72

NOTE

DOHC: Double overhead camshaft

*: Model with 4-wheel steering

GEAR RATIO TABLE

	A	B
1st	2.551	2.846
2nd	1.488	1.581
3rd	1.000	1.000
4th	0.685	0.685
Reverse	2.176	2.176

Intentionally blank

SERVICE SPECIFICATIONS

mm (in.)

Item	Standard
Transfer driven gear preload – F4A33	0.075 – 0.135 (0.0030 – 0.0053)
Low-reverse brake end play	1.0 – 1.2 (0.0394 – 0.0472)
Input shaft end play	0.3 – 1.0 (0.0118 – 0.0394)
Differential case preload – F4A33	0.075 – 0.135 (0.0030 – 0.0053)
Differential gear and pinion backlash	0.025 – 0.150 (0.0010 – 0.0059)
Oil pump side clearance	0.03 – 0.05 (0.0012 – 0.0020)
Output flange bearing end play	0 – 0.09 (0 – 0.0035)
Front clutch end play – F4A33, W4A33	0.8 – 1.0 (0.0315 – 0.0394)
– W4A32	0.7 – 0.9 (0.0276 – 0.0354)
Rear clutch end play – F4A33, W4A33	1.0 – 1.2 (0.0394 – 0.0472)
– W4A32	0.4 – 0.6 (0.0157 – 0.0236)
End clutch end play	0.60 – 0.85 (0.0236 – 0.0335)
Transfer drive gear end play	0 – 0.09 (0 – 0.0035)
Front differential case end play – W4A32, W4A33	0.045 – 0.165 (0.0018 – 0.0065)
Center differential case preload – W4A32, W4A33	0.075 – 0.135 (0.0030 – 0.0053)
Front output shaft preload – W4A32, W4A33	0.055 – 0.115 (0.0022 – 0.0045)
Center differential side gear end play – W4A32, W4A33	0.01 – 0.03 (0.0004 – 0.0012)
Bevel gear set backlash – W4A32, W4A33	0.08 – 0.13 (0.0031 – 0.0051)
Driven bevel gear turning drive torque – W4A32, W4A33 Nm (kgm, ft.lbs.)	1.0 – 1.7 (0.10 – 0.17, 0.72 – 1.23)
Drive bevel gear shaft turning drive torque – W4A32, W4A33 Nm (kgm, ft.lbs.)	1.7 – 2.5 (0.17 – 0.25, 1.23 – 1.81)

VALVE BODY SPRING IDENTIFICATION CHART

mm (in.)

Part name	Wire diameter	Outside diameter	Length	No. of turns
Regular valve spring	1.4 (0.055)	15 (0.59)	52 (2.05)	11.5
1-2 shift valve spring	0.6 (0.024)	7.6 (0.299)	26.6 (1.047)	13.5
Pressure control valve spring	0.45 (0.0177)	7.6 (0.299)	21.3 (0.839)	8.5
Rear clutch exhaust valve spring	0.7 (0.028)	6.8 (0.268)	27.4 (1.079)	12.5
End clutch valve spring				
<Up to model 1992>	0.6 (0.024)	6.6 (0.260)	24.4 (0.961)	15.5
<From model 1993>	0.8 (0.031)	7.0 (0.276)	27.5 (1.083)	15.5
2-3 shift valve spring	0.8 (0.031)	7.0 (0.276)	27.5 (1.083)	15.5
N-R control valve spring	0.7 (0.028)	9.2 (0.362)	32.1 (1.264)	8.5
Reducing valve spring	1.2 (0.047)	8.9 (0.350)	29.5 (1.161)	12.5
Line relief spring	1.0 (0.039)	7.0 (0.276)	17.3 (0.681)	10
Torque converter valve spring	1.3 (0.051)	9.0 (0.354)	22.6 (0.890)	9.5
Shift control valve spring	0.5 (0.020)	5.7 (0.224)	26.8 (1.055)	22
Damper clutch control valve spring				
<W4A32>	0.7 (0.028)	6.2 (0.244)	15.7 (0.618)	10.5
<F4A33, W4A33>	0.7 (0.028)	6.2 (0.244)	14.2 (0.559)	9.5

ADJUSTMENT PRESSURE PLATE, SNAP RINGS AND SPACERS

Part name	Thickness mm (in.)	Identification symbol	Part No.
Pressure plate – F4A33, W4A33 (For adjustment of low-reverse brake end play)	5.9 (0.232)	A	MD731736
	6.0 (0.236)	0	MD731737
	6.1 (0.240)	1	MD731738
	6.2 (0.244)	2	MD731739
	6.3 (0.248)	3	MD731740
	6.4 (0.252)	4	MD731588
	6.5 (0.256)	5	MD731741
	6.6 (0.260)	6	MD731742
	6.7 (0.264)	7	MD731743
	6.8 (0.268)	8	MD731744
Pressure plate – W4A32 (For adjustment of low-reverse brake end play)	6.9 (0.272)	9	MD731745
	5.6 (0.220)	Y	MD731720
	5.7 (0.224)	Z	MD731721
	5.8 (0.228)	8	MD727801
	5.9 (0.232)	9	MD731000
	6.0 (0.236)	0	MD727802
	6.1 (0.240)	1	MD731001
	6.2 (0.244)	2	MD727803
	6.3 (0.248)	3	MD731002
	6.4 (0.252)	4	MD727804
Snap ring – F4A33, W4A33 <Up to MODEL 1992> (For adjustment of front clutch and rear clutch end play)	6.5 (0.256)	5	MD731003
	6.6 (0.260)	6	MD727805
	6.7 (0.264)	7	MD731004
	6.8 (0.268)	X	MD731005
	6.9 (0.272)	A	MD734766
	7.0 (0.276)	B	MD734767
	1.3* (0.051)	None	MD731747
	1.4* (0.055)	Blue	MD731748
	1.5 (0.059)	Brown	MD731749
	* ... rear clutch only	1.6 (0.063)	None
1.7 (0.067)	Blue	MD731751	
1.8 (0.071)	Brown	MD731752	
1.9 (0.075)	None	MD731753	
2.0 (0.079)	Blue	MD731754	
2.1 (0.083)	Brown	MD731755	
2.2 (0.087)	None	MD731756	
2.3 (0.091)	Blue	MD731757	
2.4 (0.094)	Brown	MD731758	
Snap ring <MODEL 1993> (For adjustment of front clutch and rear clutch end play) F4A33 (except F4A33-1-UNQ5, UNQ6), W4A33	1.3 (0.051)	None	MD731747
	1.4 (0.055)	Blue	MD731748
	1.5 (0.059)	Brown	MD731749
	1.6 (0.063)	None	MD731750
	1.7 (0.067)	Blue	MD731751
	1.8 (0.071)	Brown	MD731752

Part name	Thickness mm (in.)	Identification symbol	Part No.
Snap ring <MODEL 1993> (For adjustment of front end play) F4A33-1-UNQ5, UNQ6	1.9 (0.075)	None	MD731753
	2.0 (0.079)	Blue	MD731754
	2.1 (0.083)	Brown	MD731755
	2.2 (0.087)	None	MD731756
	2.3 (0.091)	Blue	MD731757
	2.4 (0.094)	Brown	MD731758
	2.5 (0.098)	None	MD751195
	2.6 (0.102)	Blue	MD751196
	2.7 (0.106)	Brown	MD751197
	2.8 (0.110)	None	MD751198
Snap ring <MODEL 1993> (For adjustment of front clutch end play) F4A33-1-UNQ5, UNQ6	2.9 (0.114)	Blue	MD751199
	3.0 (0.118)	Brown	MD751200
	1.3 (0.051)	None	MD738370
	1.4 (0.055)	Blue	MD738371
	1.5 (0.059)	Brown	MD738372
	1.6 (0.063)	None	MD738373
	1.7 (0.067)	Blue	MD738374
	1.8 (0.071)	Brown	MD738375
	1.9 (0.075)	None	MD738376
	2.0 (0.079)	Blue	MD738377
Snap ring (For adjustment of end clutch end play)	2.1 (0.083)	Brown	MD738378
	2.2 (0.087)	None	MD738379
	2.3 (0.091)	Blue	MD738380
	2.4 (0.094)	Brown	MD738381
	1.05 (0.0413)	White	MD715800
1.30 (0.0512)	Yellow	MD715801	
1.55 (0.0610)	None	MD715802	
1.80 (0.0709)	Green	MD715803	
2.05 (0.0807)	Pink	MD720849	

Intentionally blank

Part name	Thickness mm (in.)	Identification symbol	Part No.
Snap ring – W4A32 (For adjustment of front clutch and rear clutch end play)	1.6 (0.063)	None	MD955630
	1.7 (0.067)	Brown	MD730930
	1.8 (0.071)	Blue	MD955631
	1.9 (0.075)	None	MD730931
	2.0 (0.079)	Brown	MD955632
	2.1 (0.083)	Blue	MD730932
	2.2 (0.087)	None	MD955633
	2.3 (0.091)	Brown	MD730933
	2.4 (0.094)	Blue	MD955634
	2.5 (0.098)	None	MD730934
	2.6 (0.102)	Brown	MD955635
	2.7 (0.106)	Blue	MD730935
	2.8 (0.110)	None	MD955636
2.9 (0.114)	Brown	MD730936	
3.0 (0.118)	Blue	MD955637	
Spacer (For adjustment of transfer driven gear preload)	0.62 (0.0244)	62	MD737444
	0.65 (0.0256)	65	MD737445
	0.68 (0.0268)	68	MD737446
	0.71 (0.0280)	71	MD737447
	0.74 (0.0291)	74	MD728802
	0.77 (0.0303)	77	MD728803
	0.80 (0.0315)	80	MD728804
	0.83 (0.0327)	83	MD728805
	0.86 (0.0339)	86	MD728806
	0.89 (0.0350)	89	MD728807
	0.92 (0.0362)	92	MD728808
	0.95 (0.0374)	95	MD728809
	0.98 (0.0386)	98	MD728810
	1.01 (0.0398)	01	MD728811
	1.04 (0.0409)	04	MD728812
	1.07 (0.0421)	07	MD728813
	1.10 (0.0433)	10	MD728814
1.13 (0.0445)	13	MD728815	
1.16 (0.0457)	16	MD728816	
1.19 (0.0469)	19	MD728817	
1.22 (0.0480)	22	MD728818	
1.25 (0.0492)	25	MD728819	
1.28 (0.0504)	28	MD728820	
1.31 (0.0516)	31	MD728821	
Snap ring (For adjustment of output flange bearing end play)	1.76 (0.0693)	Brown	MD733314
	1.82 (0.0717)	None	MD722538
	1.88 (0.0740)	Blue	MD721014
	1.94 (0.0764)	Brown	MD721015
	2.00 (0.0787)	None	MD721016
	2.06 (0.0811)	Blue	MD721017
	2.12 (0.0835)	Brown	MD722539
2.18 (0.0858)	None	MD733315	

Part name	Thickness mm (in.)	Identification symbol	Part No.
Spacer – F4A33 (For adjustment of differential case preload)	0.83 (0.0327)	83	MD720937
	0.86 (0.0339)	86	MD720938
	0.89 (0.0350)	89	MD720939
	0.92 (0.0362)	92	MD720940
	0.95 (0.0374)	95	MD720941
	0.98 (0.0386)	98	MD720942
	1.01 (0.0398)	01	MD720943
	1.04 (0.0409)	04	MD720944
	1.07 (0.0421)	07	MD720945
	1.10 (0.0433)	J	MD710454
	1.13 (0.0445)	D	MD700270
	1.16 (0.0457)	K	MD710455
	1.19 (0.0469)	L	MD710456
	1.22 (0.0480)	G	MD700271
	1.25 (0.0492)	M	MD710457
	1.28 (0.0504)	N	MD710458
	Spacer – W4A32, W4A33 (For adjustment of differential case end play)	1.31 (0.0516)	E
1.34 (0.0528)		O	MD710459
1.37 (0.0539)		P	MD710460
1.01 (0.0398)		01	MD720943
1.10 (0.0433)		J	MD710454
Spacer (For adjustment of differential gear and pinion backlash)	1.19 (0.0469)	L	MD710456
	1.28 (0.0504)	N	MD710458
	0.75 – 0.82 (0.0295 – 0.0323)	–	MD722986
	0.83 – 0.92 (0.0327 – 0.0362)	–	MD722985
	0.93 – 1.00 (0.0366 – 0.0394)	–	MD722984
	1.01 – 1.08 (0.0398 – 0.0425)	–	MD722982
	1.09 – 1.16 (0.0429 – 0.0457)	–	MD722983
Spacer – W4A32, W4A33 (For adjustment of center differential front side gear end play)	0.53 – 0.60 (0.0209 – 0.0236)	28	MD727928
	0.85 – 0.92 (0.0335 – 0.0362)	32	MD727932
	1.01 – 1.08 (0.0398 – 0.0425)	34	MD727934
	1.17 – 1.24 (0.0461 – 0.0498)	41	MD727941

Part name	Thickness mm (in.)	Identification symbol	Part No.
Spacer – W4A32, W4A33 (For adjustment of center differential rear side gear end play)	0.59 – 0.66 (0.0232 – 0.0260)	73	MD724973
	0.75 – 0.82 (0.0295 – 0.0323)	46	MD724946
	0.93 – 1.00 (0.0366 – 0.0394)	81	MD724981
	1.09 – 1.16 (0.0429 – 0.0457)	43	MD724943
	1.25 – 1.32 (0.0492 – 0.0520)	72	MD724972
Spacer – W4A32, W4A33 (For adjustment of drive bevel gear mount)	1.34 (0.0528)	34	MD723600
	1.37 (0.0539)	37	MD723601
	1.40 (0.0551)	40	MD723602
	1.43 (0.0563)	43	MD723603
	1.46 (0.0575)	46	MD723604
	1.49 (0.0587)	49	MD723605
	1.52 (0.0598)	52	MD723606
	1.55 (0.0610)	55	MD723607
	1.58 (0.0622)	58	MD723608
	1.61 (0.0634)	61	MD723609
	1.64 (0.0646)	64	MD726170
1.67 (0.0657)	67	MD726171	
Spacer – W4A32, W4A33 (For adjustment of drive bevel gear train preload)	1.28 (0.0504)	B28	MD726167
	1.31 (0.0516)	B31	MD726168
	1.34 (0.0528)	B34	MD726169
	1.37 (0.0539)	B37	MD724326
	1.40 (0.0551)	B40	MD724327
	1.43 (0.0563)	B43	MD724328
	1.46 (0.0575)	B46	MD724329
	1.49 (0.0587)	B49	MD724330
	1.52 (0.0598)	B52	MD724331
	1.55 (0.0610)	B55	MD724332
	1.58 (0.0622)	B58	MD724333
	1.61 (0.0634)	B61	MD724334
	1.64 (0.0646)	B64	MD724335
	1.67 (0.0657)	B67	MD724336
	1.70 (0.0669)	B70	MD724337
	1.73 (0.0681)	B73	MD724338
	1.76 (0.0693)	B76	MD724339
	1.79 (0.0705)	B79	MD724340
1.82 (0.0717)	B82	MD724341	
1.85 (0.0728)	B85	MD724342	

Part name	Thickness mm (in.)	Identification symbol	Part No.
Spacer – W4A32, W4A33 (For adjustment of driven bevel gear train preload)	1.19 (0.0469)	19	MD726172
	1.22 (0.0480)	22	MD722081
	1.25 (0.0492)	25	MD722082
	1.28 (0.0504)	28	MD722083
	1.31 (0.0516)	31	MD722084
	1.34 (0.0528)	34	MD722085
	1.37 (0.0539)	37	MD722086
	1.40 (0.0551)	40	MD722087
	1.43 (0.0563)	43	MD722088
	1.46 (0.0575)	46	MD722089
	1.49 (0.0587)	49	MD722090
	1.52 (0.0598)	52	MD722091
	1.55 (0.0610)	55	MD722092
	1.58 (0.0622)	58	MD722093
	1.61 (0.0634)	61	MD722094
	1.64 (0.0646)	64	MD722095
	1.67 (0.0657)	67	MD722096
	1.70 (0.0669)	70	MD722097
	1.73 (0.0681)	73	MD722098
	1.76 (0.0693)	76	MD722099
1.79 (0.0705)	79	MD722100	
1.82 (0.0717)	82	MD722101	
1.85 (0.0728)	85	MD722102	
1.88 (0.0740)	88	MD722103	
1.91 (0.0752)	91	MD722104	
1.94 (0.0764)	94	MD722105	
Spacer – W4A32, W4A33 (For adjustment of driven bevel gear mount)	0.13 (0.0051)	13	MD720353
	0.16 (0.0063)	16	MD720354
	0.19 (0.0075)	19	MD720355
	0.22 (0.0087)	22	MD720356
	0.25 (0.0098)	25	MD720357
	0.28 (0.0110)	28	MD720358
	0.31 (0.0122)	31	MD720359
	0.34 (0.0134)	34	MD720360
	0.37 (0.0146)	37	MD720361
	0.40 (0.0517)	40	MD720362
	0.43 (0.0169)	43	MD720363
	0.46 (0.0181)	46	MD720364
0.49 (0.0193)	49	MD720365	
0.52 (0.0205)	52	MD720366	

Part name	Thickness mm (in.)	Identification symbol	Part No.
Spacer – W4A32, W4A33 (For adjustment of front output bearing preload)	1.16 (0.0457)	16	MD736929
	1.19 (0.0469)	19	MD736751
	1.22 (0.0480)	22	MD736931
	1.25 (0.0492)	25	MD726166
	1.28 (0.0504)	28	MD718517
	1.31 (0.0516)	31	MD718518
	1.34 (0.0528)	34	MD718519
	1.37 (0.0539)	37	MD718520
	1.40 (0.0551)	40	MD718521
	1.43 (0.0563)	43	MD718522
	1.46 (0.0575)	46	MD718523
	1.49 (0.0587)	49	MD718524
	1.52 (0.0598)	52	MD718525
	1.55 (0.0610)	55	MD718526
	1.58 (0.0622)	58	MD718527
	1.61 (0.0634)	61	MD718528
	1.64 (0.0646)	64	MD718529
1.67 (0.0657)	67	MD718530	
1.70 (0.0669)	70	MD718531	
1.73 (0.0681)	73	MD721959	
1.76 (0.0693)	76	MD721960	

SEALANTS AND ADHESIVES

<W4A32, W4A33>

Items	Specified sealants and adhesives
Transfer extension housing-Transfer adapter	Mitsubishi genuine sealant Part No. MD997740 or equivalent
Front bearing retainer bolts Center differential flange bolts	3M STUD Locking Part No. 4170 or equivalent
Air breather	3M SUPER WEATHERSTRIP No. 8001 or equivalent

TORQUE SPECIFICATIONS**TRANSMISSION**

	Torque		
	Nm	kgm	ft.lbs.
Air exhaust plug	33	3.3	24
Detent plate mounting bolt <MODEL 1993>	11	1.1	8
Differential cover bolt	11	1.1	8
Differential drive gear bolt	135	13.5	98
Differential front bearing cap bolt	70	7.0	51
Differential rear bearing retainer bolt	35	3.5	26
End clutch cover bolt	11	1.1	8
Idler gear cover bolt	11	1.1	8
Idler shaft lock bolt	38	3.8	28
Inhibitor switch bolt	11	1.1	8
Kickdown servo lock nut	29	2.9	21
Manual control lever nut	19	1.9	14
Manual control shaft set screw	9	0.9	7
Oil drain bolt	33	3.3	24
Oil filter bolt	6	0.6	5
Oil level gauge guide bolt	24	2.4	18
Oil pan bolt	11	1.1	8
Oil pressure check plug	5	0.5	4
Oil pump assembly mounting bolt	21	2.1	16
Oil pump bolt	11	1.1	8
Output bearing retainer bolt	24	2.4	18
Output flange bearing retainer bolt	20	2.0	15
Parking rod support bolt	24	2.4	18
Pulse generator bolt	11	1.1	8
Roll stopper bracket bolt	49	4.9	35
Shift control cable bracket bolt	24	2.4	18
Speedometer gear locking plate bolt	5	0.5	4
Transmission mount bracket bolt	70	7.0	51
Valve body assembly mounting bolt	11	1.1	8
Valve body bolt	5	0.5	4
Center bearing retainer stopper bolt – W4A32, W4A33	5	0.5	4
Center differential drive gear bolt – W4A32, W4A33	75	7.5	54
Front bearing retainer bolt – W4A32, W4A33	49	4.9	35



TRANSFER <W4A32, W4A33>



	Torque		
	Nm	kgm	ft.lbs.
Cover mounting bolt	5	0.5	4
Driven bevel gear lock nut	150	15	108
Extension housing mounting bolt	19	1.9	14
Oil drain plug	33	3.3	24
Oil filler plug	33	3.3	24
Transfer case adapter mounting bolt	39	3.9	28
Transfer cover mounting bolt	39	3.9	28

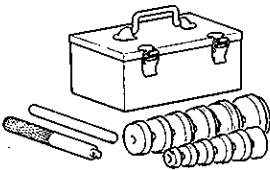
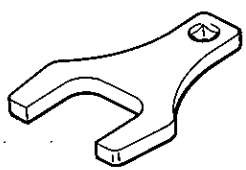
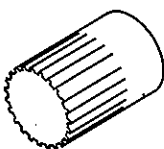
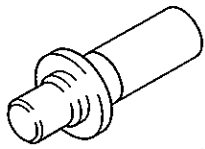
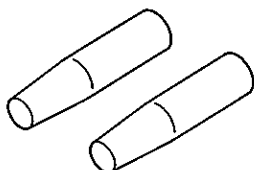
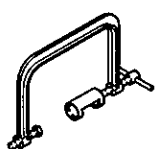
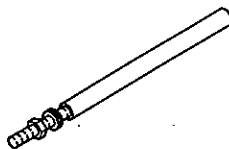

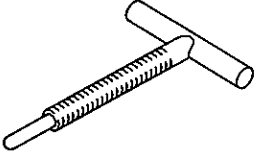
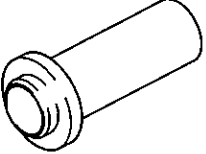
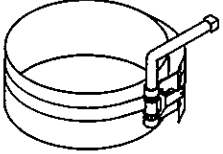
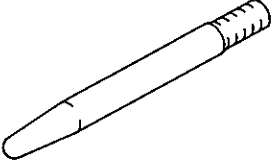
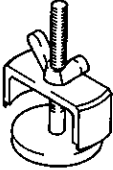
NOTES

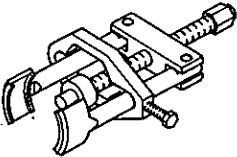

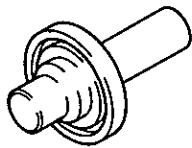
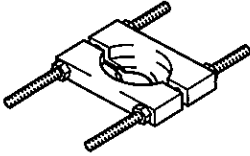
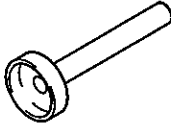
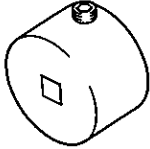
2. SPECIAL TOOLS

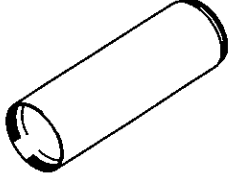
Tool	Number	Name	Use
	MB990925	Bearing and oil seal installer	Installation of bearing outer race
	MB991013	Special spanner	Installation and removal of drive bevel gear lock nut (W4A32, W4A33)
	MB991144	Side gear holding tool	Measurement of transfer drive gear drive torque (W4A32, W4A33)
	MD998200	Front bearing retainer oil seal installer	Installation of rear output shaft oil seal (W4A32, W4A33) Installation of transfer case oil seal (W4A32, W4A33)
	MD998266	Guide pin	Reassembly of valve body
	MD998303	Valve spring compressor	Removal and installation of kickdown servo
	MD998316	Dial gauge support	Installation of dial gauge

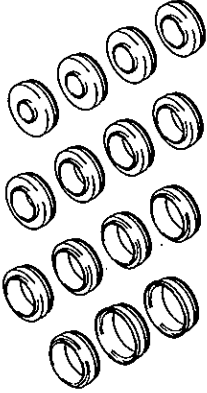
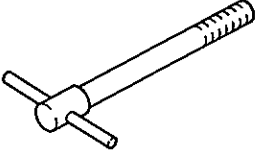
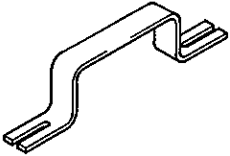

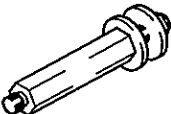
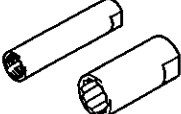
Tool	Number	Name	Use
	MD998333	Oil pump remover	Removal and installation of oil pump Removal and installation of center differential (W4A32, W4A33)
	MD998334	Oil seal installer	Installation of oil pump oil seal
	MD998335	Oil pump band	Reassembly of oil pump
	MD998336	Guide pin	Removal and installation of oil pump assembly
	MD998337	Spring compressor	Disassembly and reassembly of front clutch and rear clutch
	MD998338	Spring compressor	Disassembly and reassembly of rear clutch
	MD998348	Bearing and gear puller	Removal of transfer shaft bearing (F4A33)

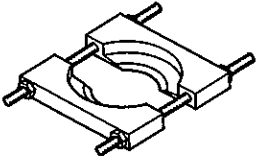
Tool	Number	Name	Use
	MD998800	Oil seal installer	Installation of differential bearing retainer oil seal
	MD998801	Bearing remover	Removal of bearing
	MD998803	Differential oil seal installer	Installation of transmission case oil seal
	MD998806	Wrench adapter	Measurement of driven bevel gear rotating torque (W4A32, W4A33)
	MD998812	Installer cap	Installation of respective bearings
	MD998813	Installer (100)	Installation of respective bearings
	MD998814	Installer (200)	Installation of respective bearings

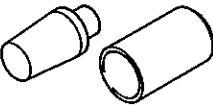
Tool	Number	Name	Use
	MD998815 MD998816 MD998817 MD998818 MD998819 MD998820 MD998821 MD998822 MD998823 MD998824 MD998825 MD998826 MD998827 MD998828 MD998829 MD998830	Installer adapter	Installation of each bearing
	MD998904	Bolt	Removal of idler shaft
	MD998905	Handle	Removal and installation of center support
	MD998907	Spring compressor	Disassembly and reassembly of front clutch and rear clutch
	MD998815	Kickdown servo wrench adapter	Adjustment of kickdown servo
	MD998916	Kickdown servo adjust wrench set	Adjustment of kickdown servo

Tool	Number	Name	Use
	MD998917	Bearing remover	Disassembly and reassembly of output flange
	MD998918	Kickdown servo wrench	Adjustment of kickdown servo
	MD998919	Snap ring installer	Reassembly of end clutch

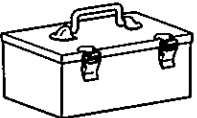
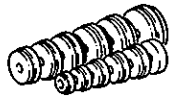
CONTENTS OF BEARING AND OIL SEAL INSTALLER SET MB990925

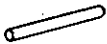
Set	Contents			
	Tool	Name	Tool No.	Diameter mm (in.)
Bearing and oil seal installer set MB990925 		Installer adapter	MB990926	39 (1.535)
			MB990927	45 (1.772)
			MB990928	49.5 (1.949)
			MB990929	51 (2.008)
			MB990930	54 (2.126)
			MB990931	57 (2.244)
			MB990932	61 (2.402)
			MB990933	63.5 (2.500)
			MB990934	67.5 (2.657)
			MB990935	71.5 (2.815)
			MB990936	75.5 (2.972)
			MB990937	79 (3.110)
		Installer bar	MB990938	–
		Brass bar	MB990939	–

NOTES

3. TRANSMISSION (F4A33)

COMPONENTS

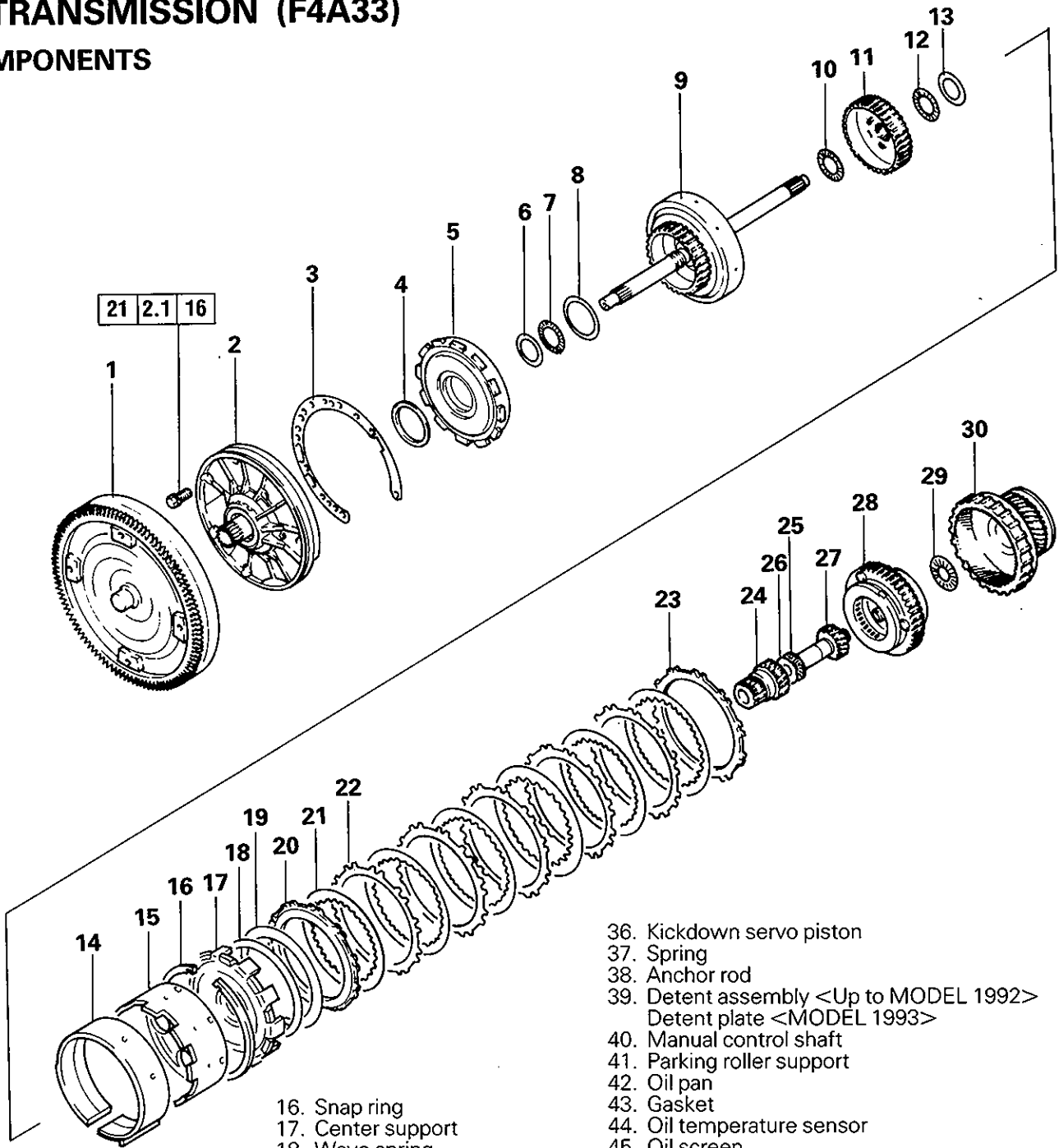

- 1. Torque converter
- 2. Oil pump assembly
- 3. Gasket
- 4. Thrust washer #1
- 5. Front clutch assembly
- 6. Thrust race #3
- 7. Thrust bearing #4
- 8. Thrust washer #2
- 9. Rear clutch assembly
- 10. Thrust bearing #5
- 11. Rear clutch hub
- 12. Thrust bearing #7
- 13. Thrust race #6
- 14. Kickdown band
- 15. Kickdown drum

- 16. Snap ring
- 17. Center support
- 18. Wave spring
- 19. Return spring
- 20. Pressure plate
- 21. Brake disc
- 22. Brake plate
- 23. Reaction plate
- 24. Reverse sun gear
- 25. Thrust bearing #8
- 26. Thrust race #9
- 27. Forward sun gear
- 28. Planetary carrier assembly
- 29. Thrust bearing #10
- 30. Output flange
- 31. Oil level gauge
- 32. Oil filler tube
- 33. Snap ring
- 34. Kickdown servo switch
- 35. Snap ring

- 36. Kickdown servo piston
- 37. Spring
- 38. Anchor rod
- 39. Detent assembly <Up to MODEL 1992>
Detent plate <MODEL 1993>
- 40. Manual control shaft
- 41. Parking roller support
- 42. Oil pan
- 43. Gasket
- 44. Oil temperature sensor
- 45. Oil screen
- 46. Valve body assembly
- 47. Manual control lever
- 48. Inhibitor switch
- 49. End clutch shaft
- 50. Bearing retainer
- 51. Thrust bearing #11
- 52. End clutch hub
- 53. Thrust washer
- 54. End clutch assembly
- 55. O-ring
- 56. End clutch cover
- 57. Pulse generator
- 58. Lock bolt
- 59. Idler shaft
- 60. Idler gear
- 61. Spacer
- 62. Gasket

TFA1262

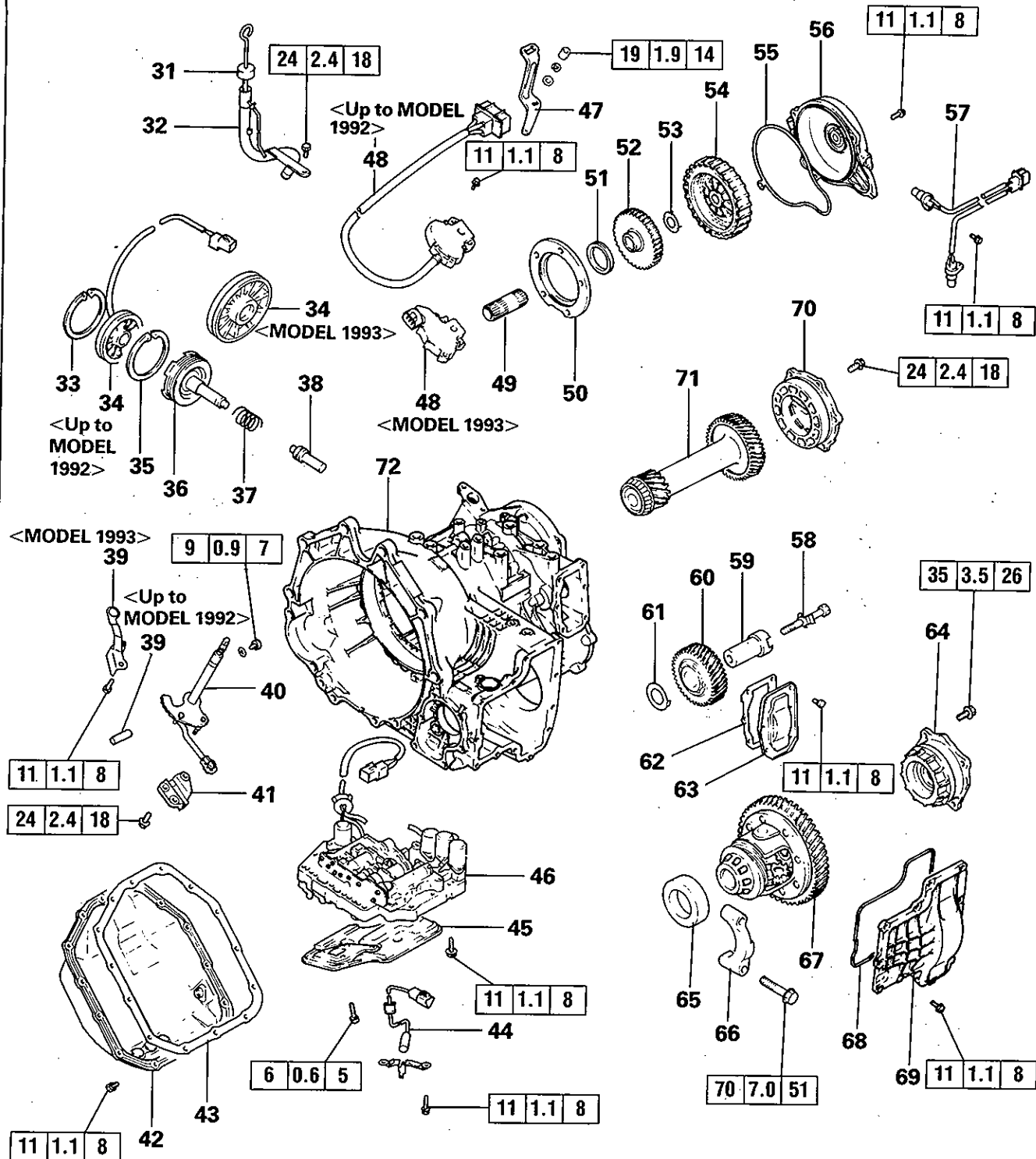

- 63. Idler gear cover
- 64. Differential bearing retainer
- 65. Outer race
- 66. Differential front bearing cap
- 67. Differential assembly
- 68. Gasket
- 69. Differential cover
- 70. Outer bearing retainer
- 71. Transfer shaft
- 72. Transmission case

Details of Change

Special Bolt

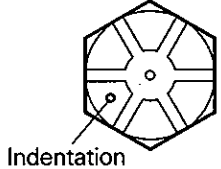
	Up to 1991 model	From 1992 model
Tread pitch	1.5 mm	1.25 mm
Identification	-	

①

Torque Converter

In accordance with the change of the special bolt, the thread pitch of the tapped hole in the torque converter has been changed from 1.5 mm to 1.25 mm.

	Up to 1991 model	From 1992 model
Identification mark	MM*	3M*

* The identification marks are stamped on the front surface of the torque converter.

Intentionally blank

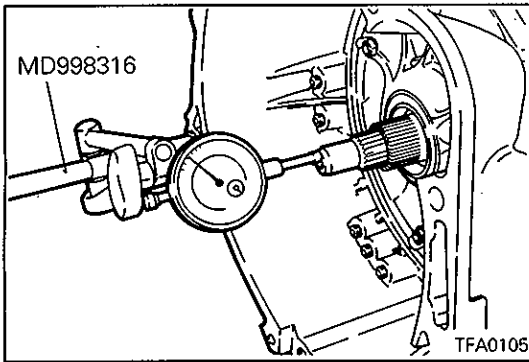
**DISASSEMBLY**

1. Clean away any sand, mud, etc. if present around the transmission.
2. Place the transmission assembly on the workbench with the oil pan down.
3. Remove the torque converter.
4. Use the special tool to fix the dial gauge on the transmission case and measure the end play of the input shaft.

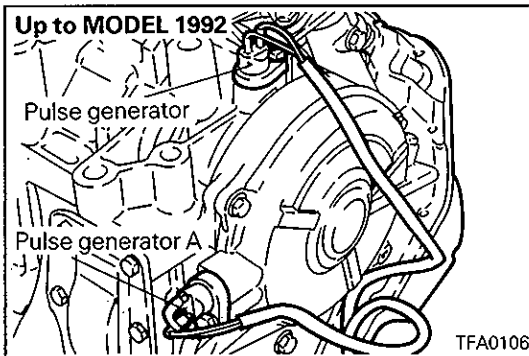

5. Remove pulse generators "A" and "B".

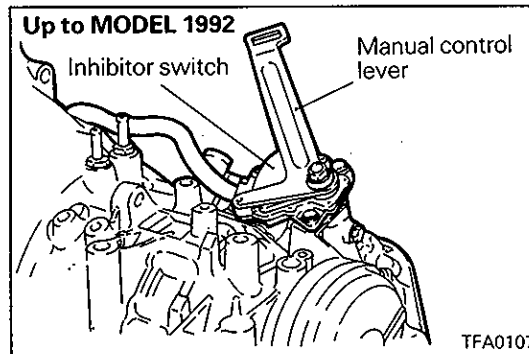
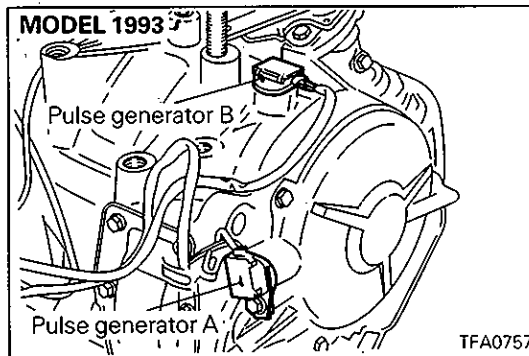

6. Remove the manual control lever, then remove the inhibitor switch.

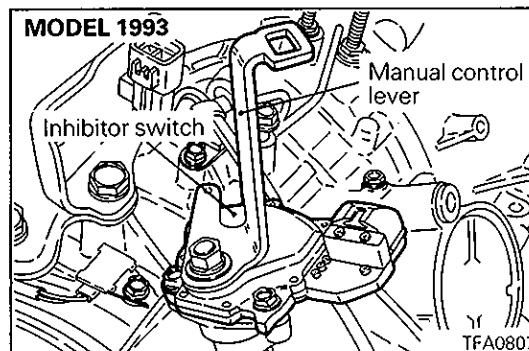

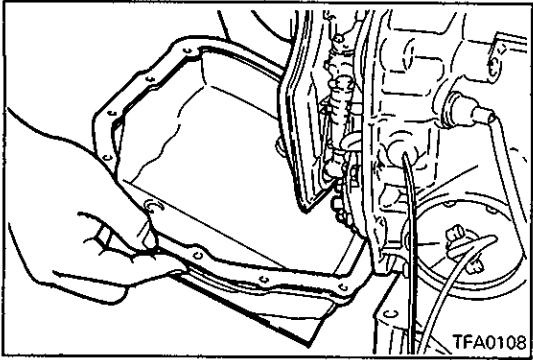

7. Remove the oil pan, the magnets and the gasket.

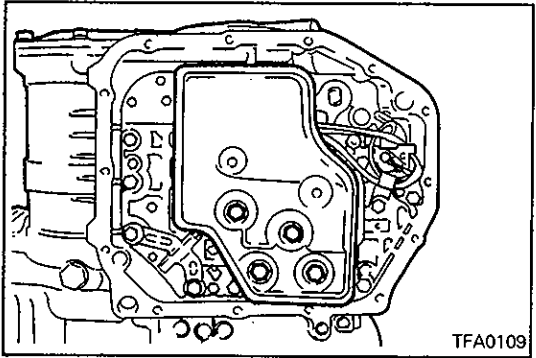

8. Remove the oil filter from the valve body.

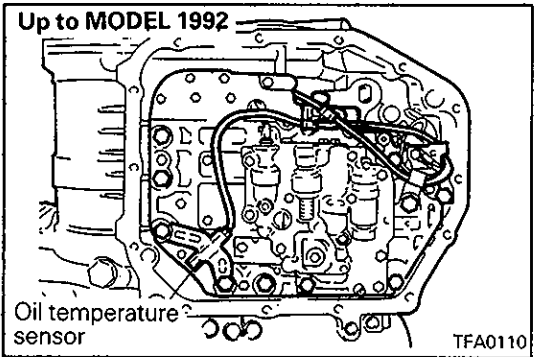

9. Remove the valve body mounting bolts at 10 places.

10. Remove the oil temperature sensor holder and unclamp the oil temperature sensor harness.

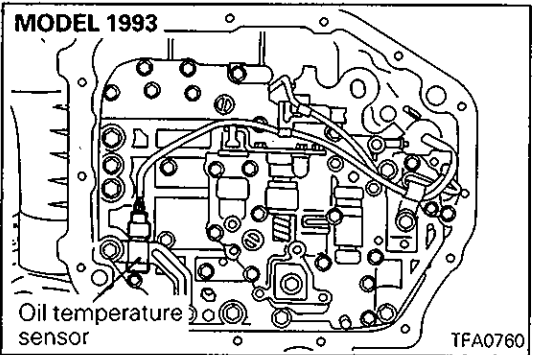

11. Press the finger of the solenoid valve harness grommet, push the grommet into the case and remove the valve body assembly.

12. Pull out the oil temperature sensor.

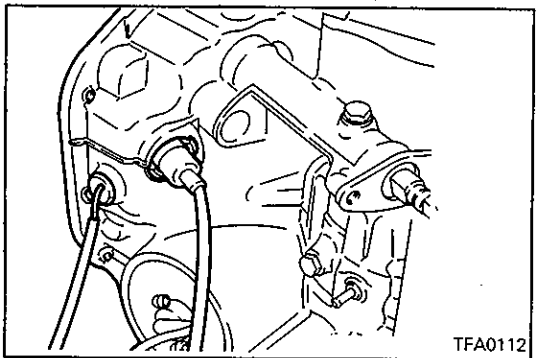

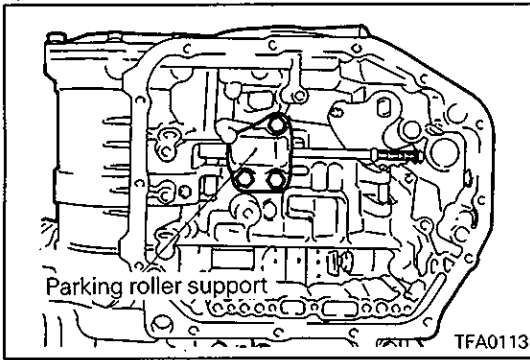

13. Remove the parking roller support.

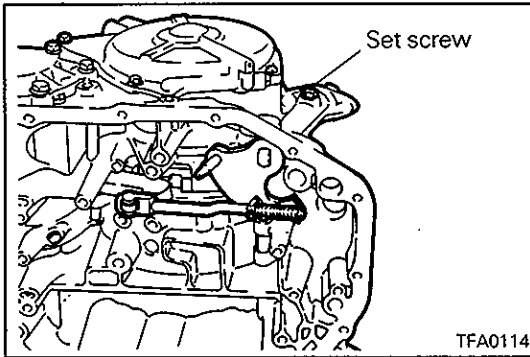

14. Remove the set screw of the manual control shaft and remove the manual control shaft assembly.
15. Remove the detent assembly.

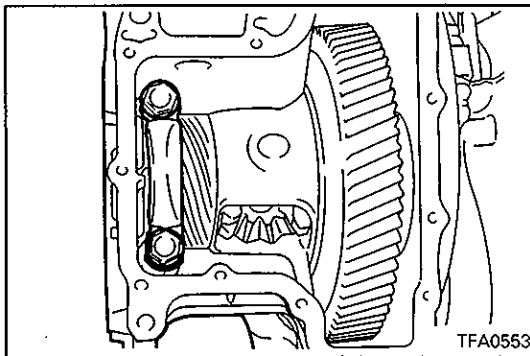

16. Remove the differential cover and the gasket.
17. Remove the differential front bearing cap.

Intentionally blank

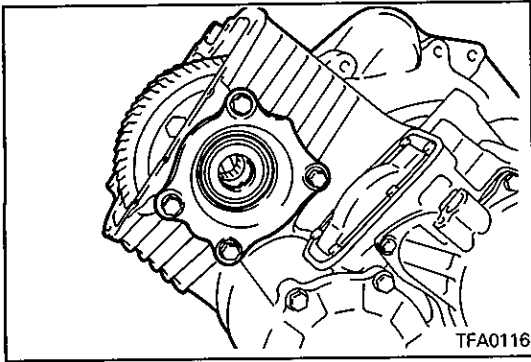

18. Remove the differential bearing retainer, the spacer and the outer race.

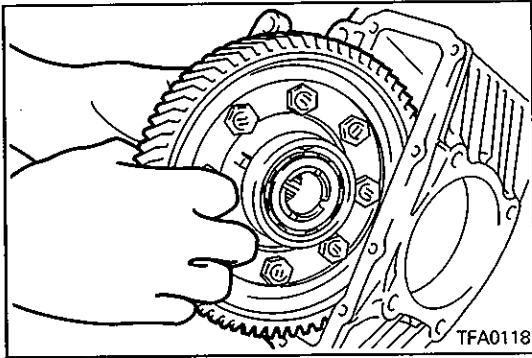

19. Remove the differential assembly.

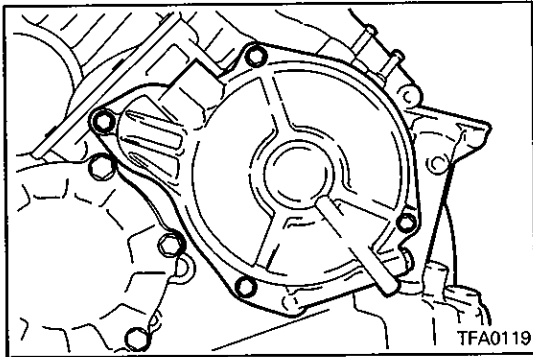

20. Remove the end clutch cover mounting bolts, then remove the cover holder and the end clutch cover.

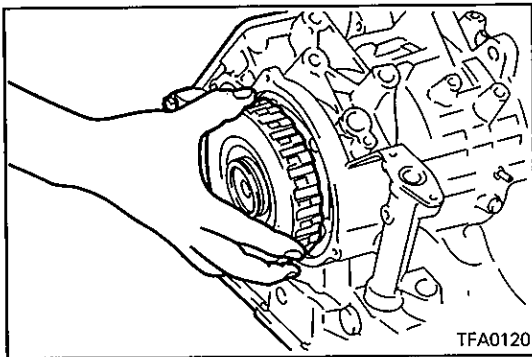

21. Remove the end clutch assembly.

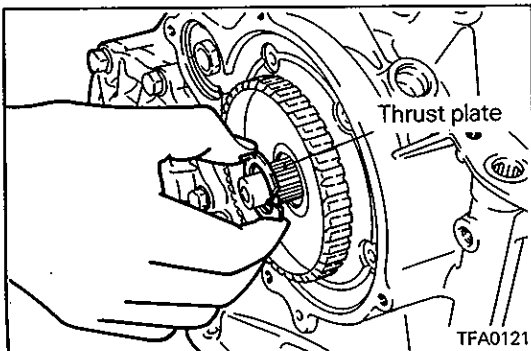

22. Remove the thrust plate.

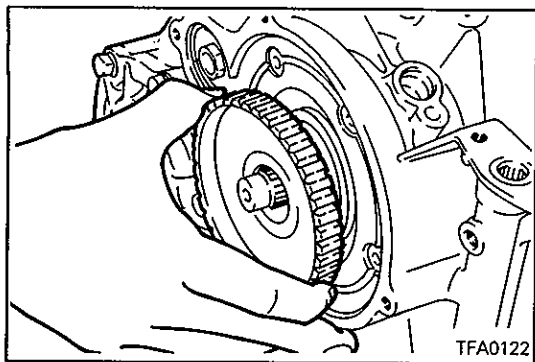

23. Remove the end clutch hub.

24. Remove thrust bearing #11.

NOTE

The thrust bearing may be stuck to the end clutch hub.

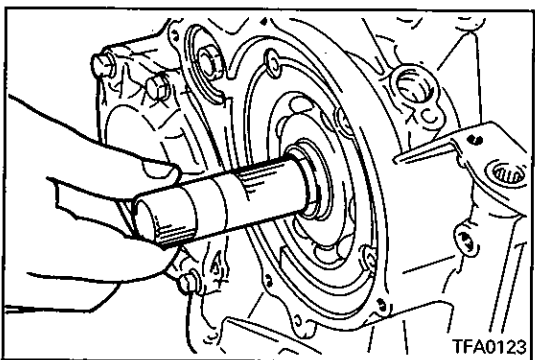

25. Pull out the end clutch shaft.

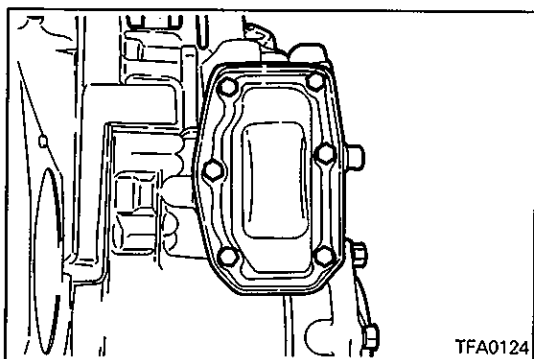

26. Remove the idler gear cover mounting bolts, then remove the idler gear cover and the gasket.

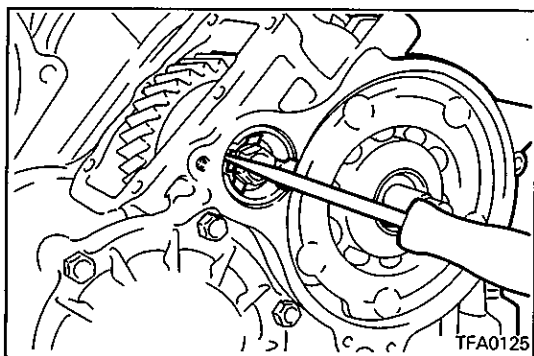

27. Disengage the bolt stopper and remove the bolt.

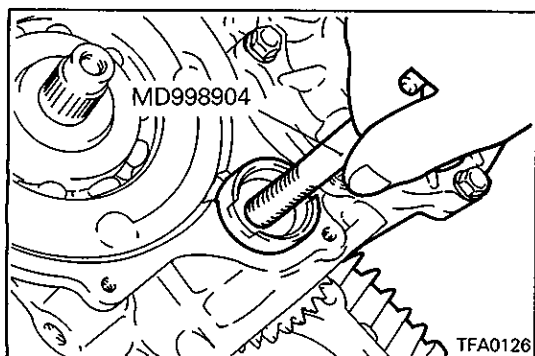

28. Using the special tool, pull out the idler shaft and then remove the idler gear and the bearing inner race.

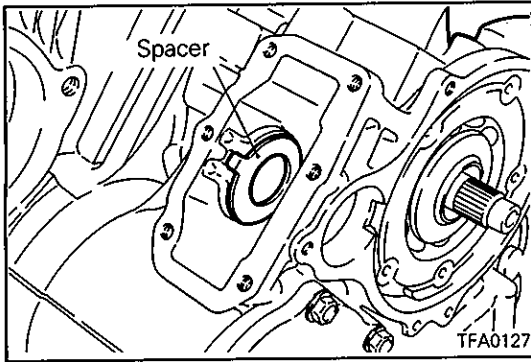

29. Remove the spacer.

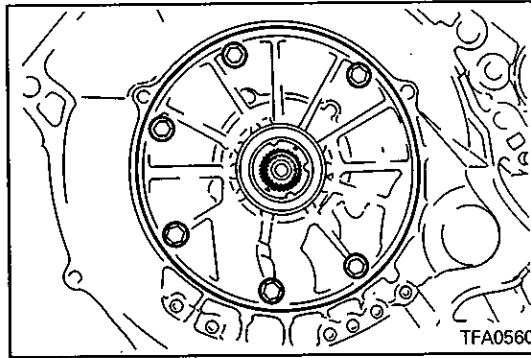

30. Remove the oil pump mounting bolts.

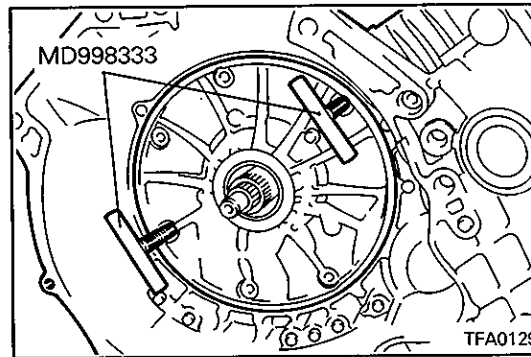

31. Use the special tool to remove the oil pump.

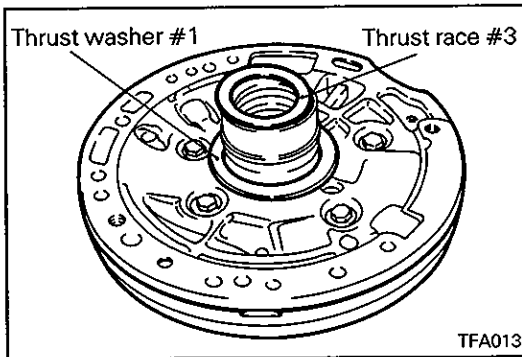

32. Remove thrust washer #1 and thrust race #3.

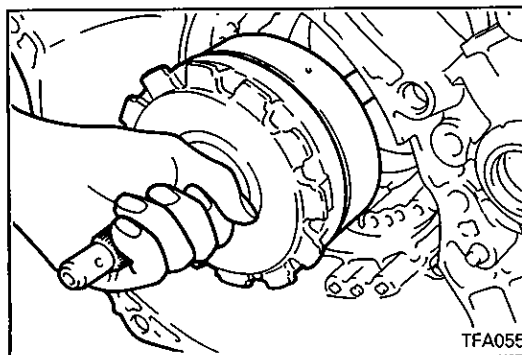

33. Hold the input shaft and remove the front and rear clutch assemblies together.

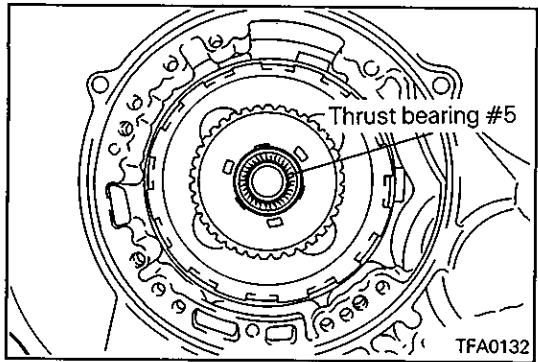

34. Remove thrust bearing #5.

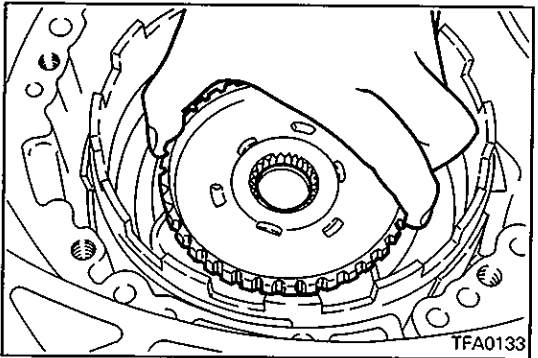

35. Remove the clutch hub.

NOTE

The thrust race may be stuck to the clutch hub.

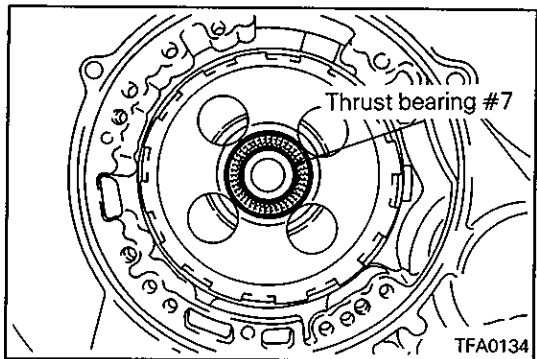

36. Remove thrust bearing #7.

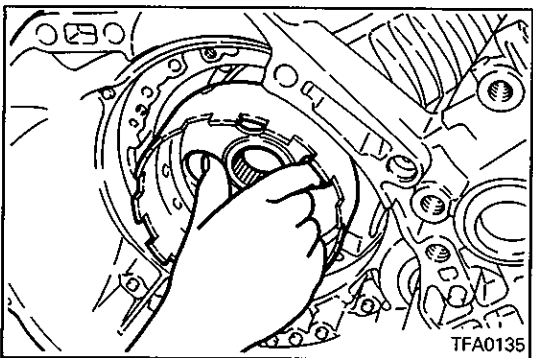

37. Remove the kickdown drum.

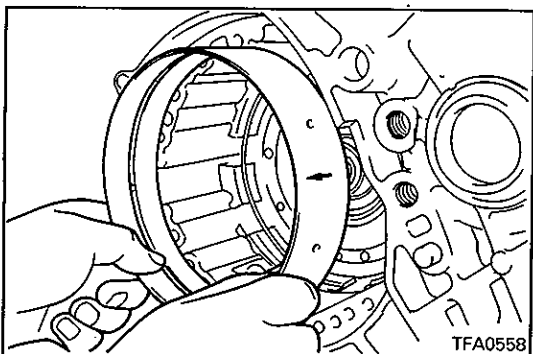

38. Remove the kickdown band.

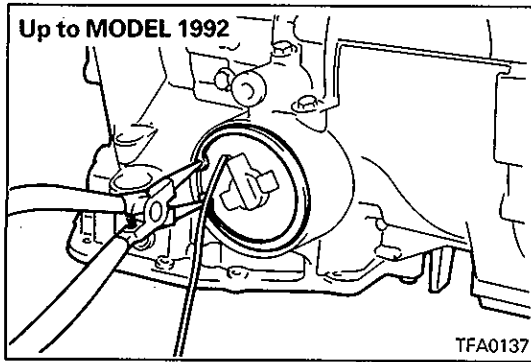

39. Remove the kickdown servo cover snap ring. Remove the kickdown servo switch.

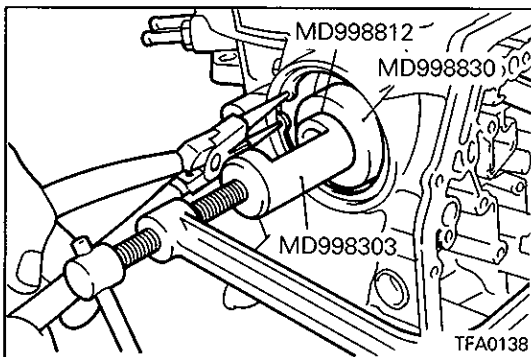
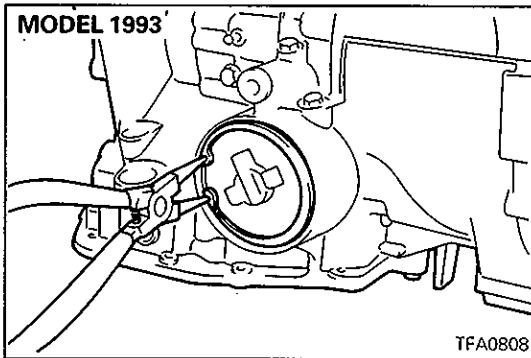

40. Using the special tool, hold the kickdown servo pressed inward and remove the snap ring.

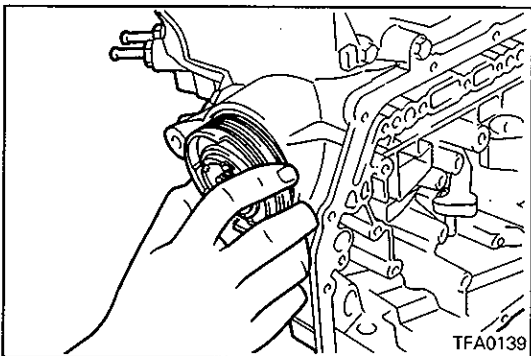

41. Remove the kickdown servo piston.

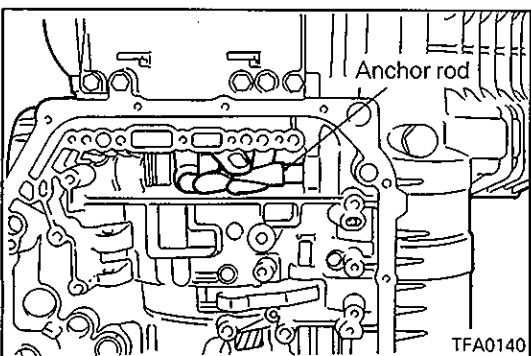

42. Remove the anchor rod.

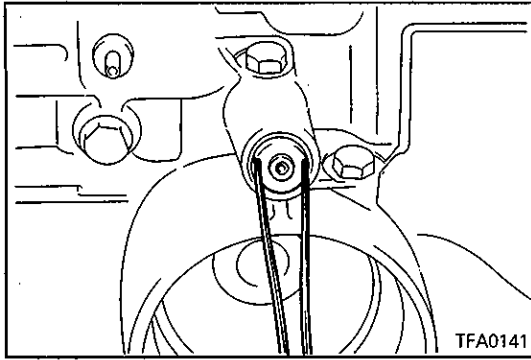

43. Remove the plug, then remove the air exhaust plug.

Intentionally blank

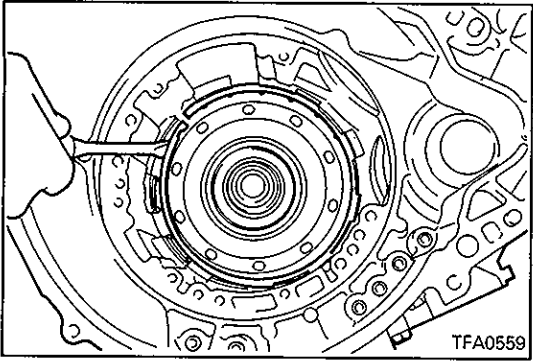

44. Remove the snap ring.

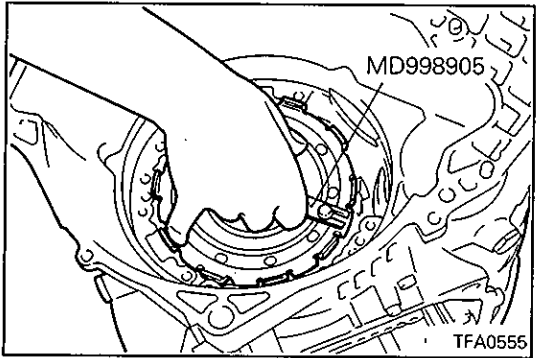

45. Using the special tool, remove the center support.

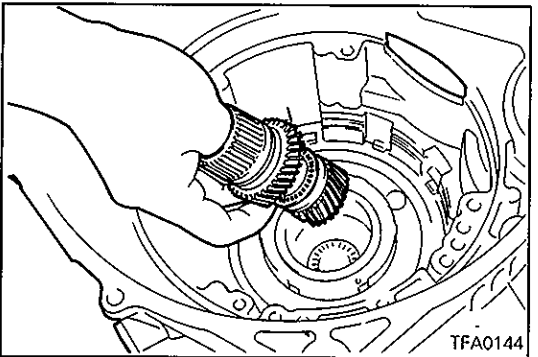

46. Remove the reverse and forward sun gears together.

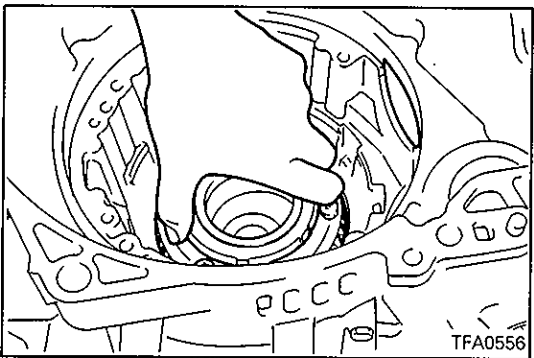

47. Remove the planet carrier assembly.

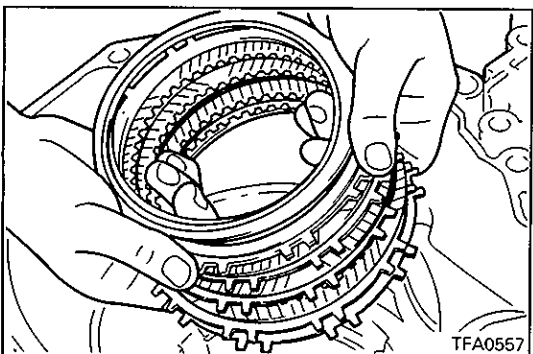

48. Remove the wave spring, return spring, reaction plate, brake discs, and brake plates.

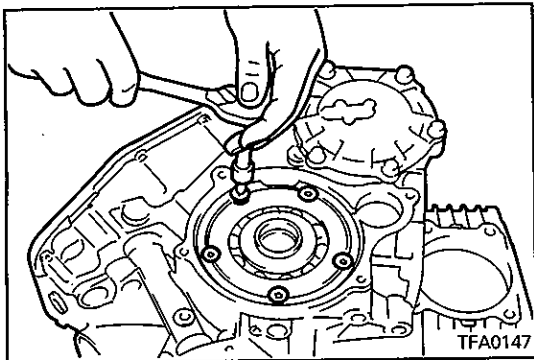

49. Remove the screws and the rear bearing retainer.

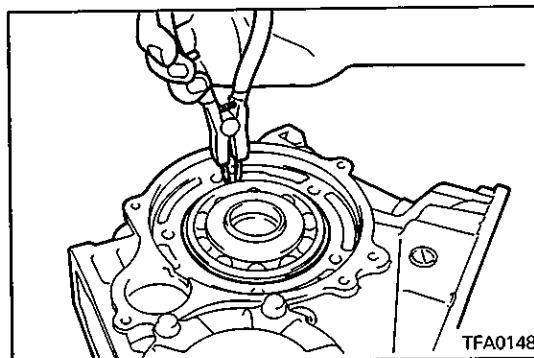

50. Remove the snap ring and then remove the output flange assembly.

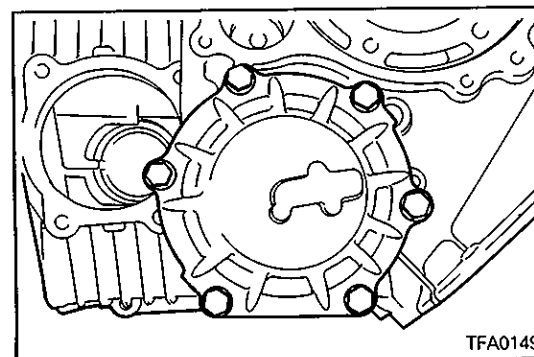

51. Remove the output bearing retainer mounting bolts and then remove the output bearing retainer and outer race.

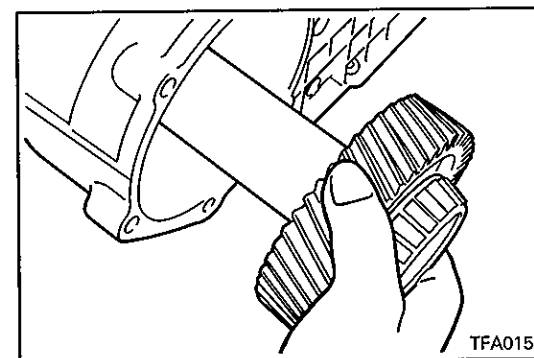

52. Remove the transfer shaft.

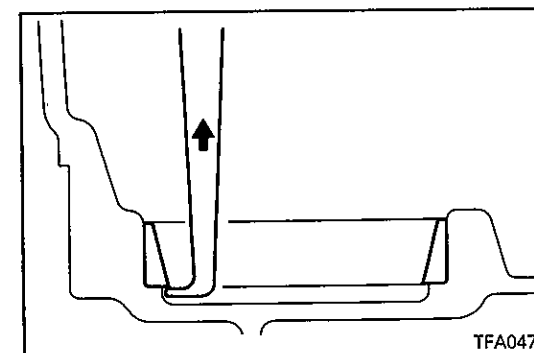

53. Using a sliding hammer or similar tool, remove the outer race.
 54. Remove all oil seals.

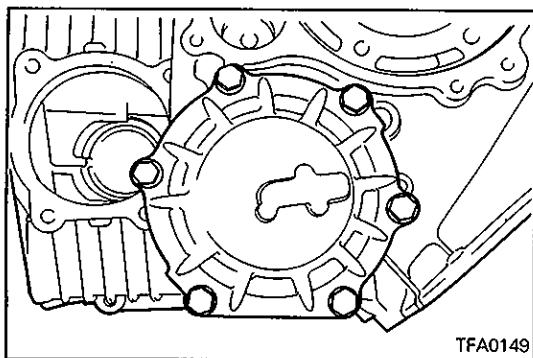
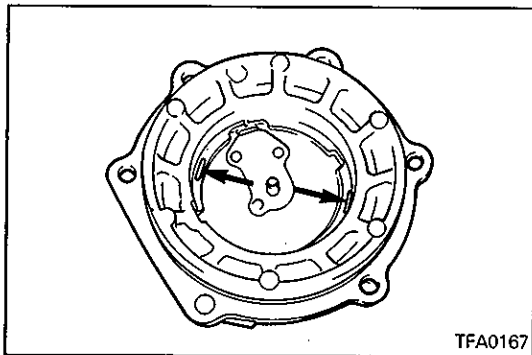
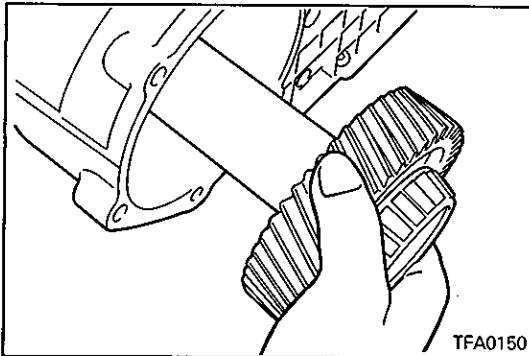
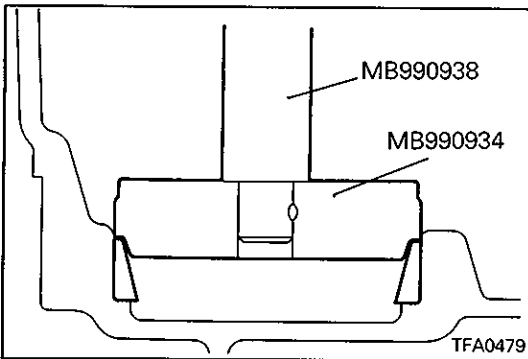
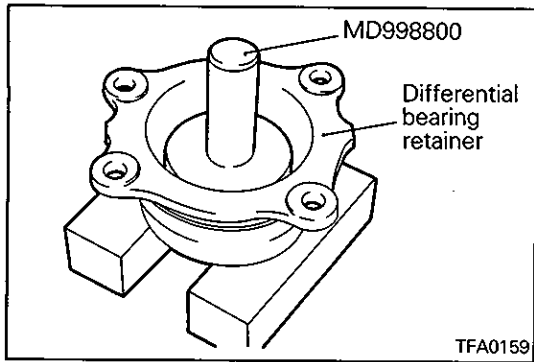

REASSEMBLY

1. Using the special tool, install the oil seals to the differential bearing retainer and the transmission case.

	Special tool
Oil seal for differential bearing retainer	MD998800
Oil seal for transmission case	MD998800 (MD998803*)

*: Vehicles with 4-wheel steering oil pump

2. Use the special tool to press fit the outer race into the transmission case.

3. Install the transfer shaft.

4. Place two pieces of approx. 10 mm (0.39 in.) long, 1.6 mm (0.06 in.) diameter solder on the output bearing retainer at the positions shown in the diagram and install the outer race.

5. Install the output bearing retainer and tighten the bolts to the specified torque.
6. Loosen the bolts and remove the output bearing retainer.

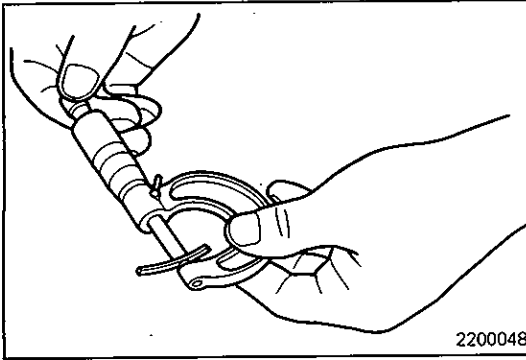

7. Remove the outer race from the output bearing retainer and remove the solder. If the solder is not crushed, repeat steps 4 – 6, using a 3 mm (0.12 in.) diameter solder. Measure the thickness of the crushed solder with a micrometer and select a spacer with a thickness that will provide the standard preload value.

Standard value: 0.075 – 0.135 mm (0.003 – 0.0053 in.)

8. Install the selected spacer and the outer race on the output bearing retainer.

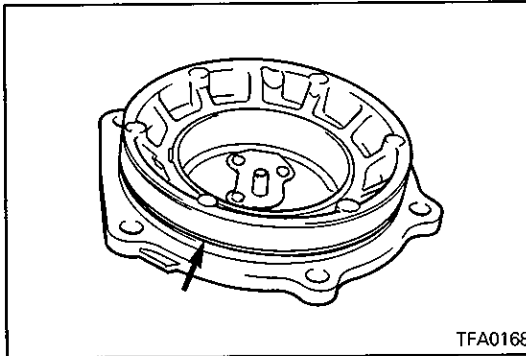

9. Install a new O-ring on the outer circumference of the outer bearing retainer.

10. Coat the O-ring with automatic transmission fluid and tighten the output bearing retainer mounting bolts to the specified torque.

**Output bearing retainer mounting bolts:
24Nm (2.4 kgm, 18 ft.lbs.)**

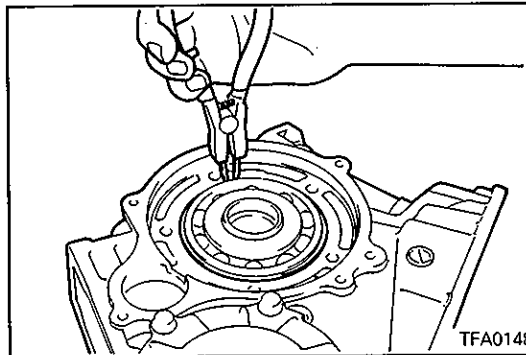

11. Insert the output flange into the case and install the snap ring around the bearing.

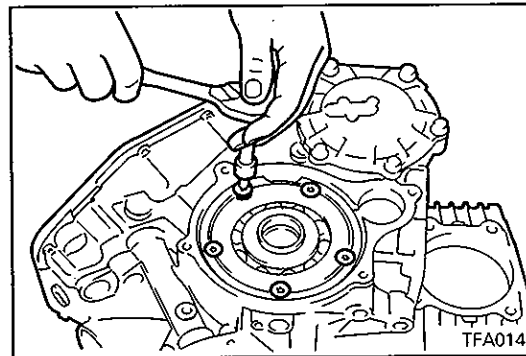

12. Install the bearing retainer using new bolts.

**Bearing retainer mounting bolts:
20 Nm (2.0 kgm, 15 ft.lbs.)**

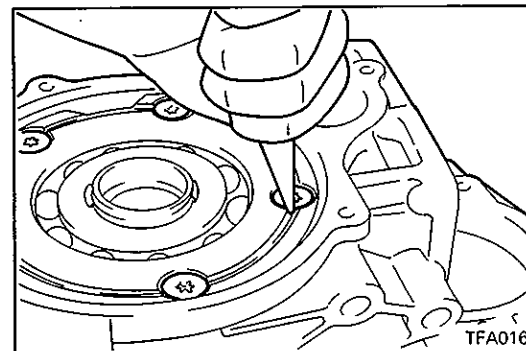

13. Caulk the head of each bolt.

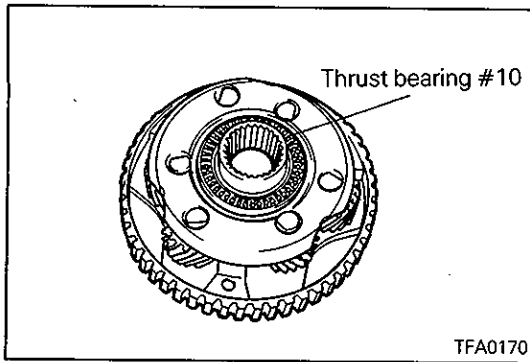

14. Apply a coating of petrolatum to thrust bearing #10 and attach the bearing to the planetary carrier.

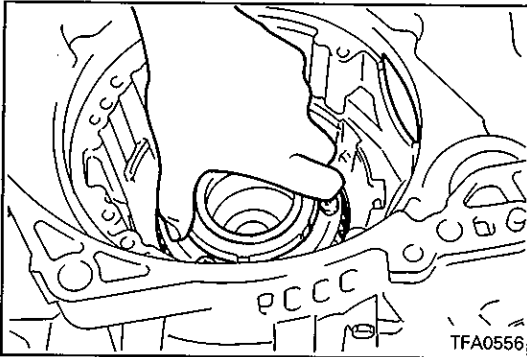

15. Install the planetary carrier in place.

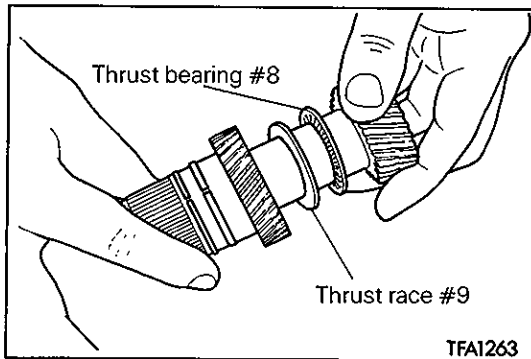

16. Assemble thrust race #9, thrust bearing #8 and the reverse sun gear on the forward sun gear.

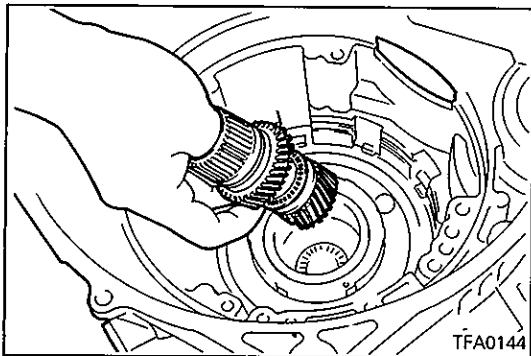

17. Install the forward and reverse sun gear assembly into the planetary carrier.

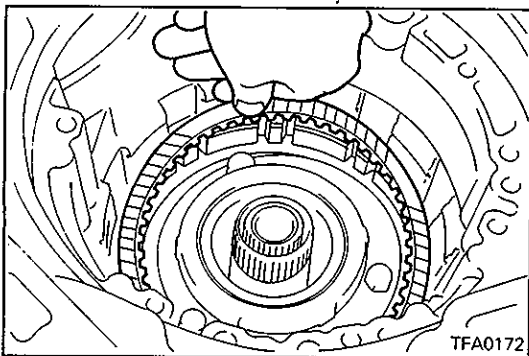

18. Assemble the reaction plate, the brake disc and the brake plate.

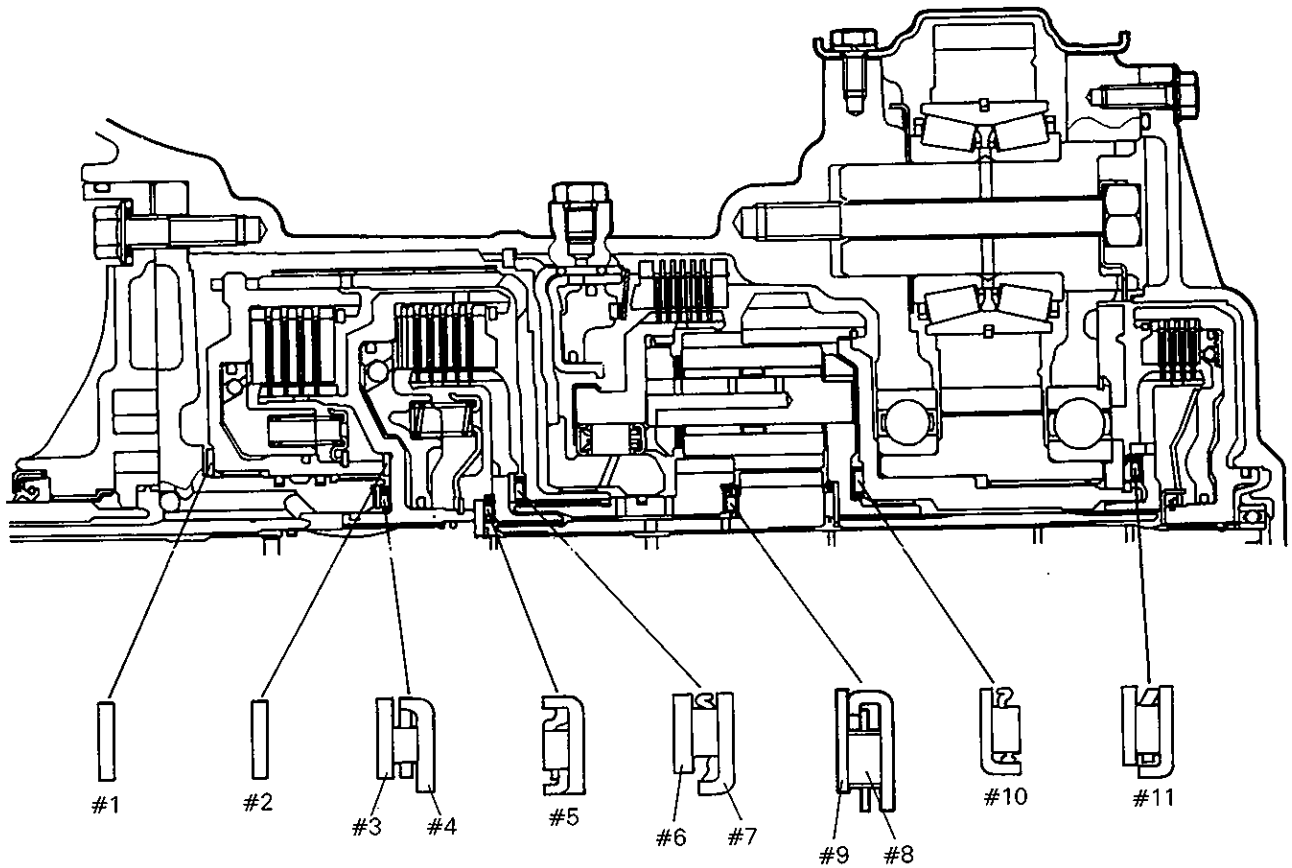

TFA1264

Identification of thrust bearings, thrust races and thrust washers

Unit: mm (in.)

D	d	t	Part No.	Sym- bol	D	d	t	Part No.	Sym- bol
70 (2.76)	55.7 (2.193)	1.4 (0.055)	*1	#1	48.1 (1.894)	34.4 (1.354)	–	MD707271	#4
70 (2.76)	55.7 (2.193)	1.8 (0.071)	*2		42.6 (1.677)	28 (1.10)	–	MD720753	#5
70 (2.76)	55.7 (2.193)	2.2 (0.087)	*3		54 (2.13)	38.7 (1.524)	1.6 (0.063)	MD704936	#6
70 (2.76)	55.7 (2.193)	2.6 (0.102)	*4		52 (2.05)	36.4 (1.433)	–	MD720010	#7
66 (2.60)	54 (2.13)	1.8 (0.071)	MD731212	#2	45 (1.77)	28 (1.10)	–	MD735062	#8
48.9 (1.925)	37 (1.46)	1.0 (0.039)	MD997854 (incl. *1)	#3	46 (1.81)	31 (1.22)	0.8 (0.031)	MD735063	#9
48.9 (1.925)	37 (1.46)	1.2 (0.047)	MD997847 (incl. *1)		52 (2.05)	36.4 (1.433)	–	MD720010	#10
48.9 (1.925)	37 (1.46)	1.4 (0.055)	MD997848 (incl. *2)		58 (2.28)	44 (1.73)	–	MD724206	#11
48.9 (1.925)	37 (1.46)	1.6 (0.063)	MD997849 (incl. *2)						
48.9 (1.925)	37 (1.46)	1.8 (0.071)	MD997850 (incl. *3)						
48.9 (1.925)	37 (1.46)	2.0 (0.079)	MD997851 (incl. *3)						
48.9 (1.925)	37 (1.46)	2.2 (0.087)	MD997852 (incl. *4)						
48.9 (1.925)	37 (1.46)	2.4 (0.094)	MD997853 (incl. *4)						

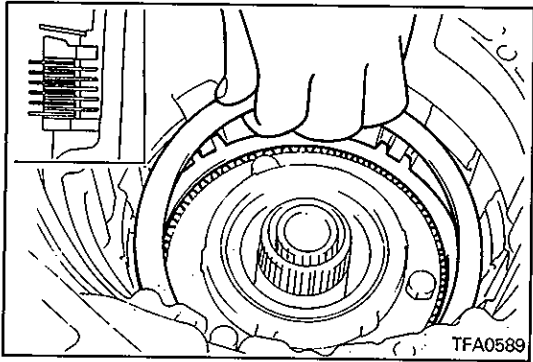

19. Install the originally installed pressure plate and install the return spring.

Caution

- Position the return spring correctly when installing.

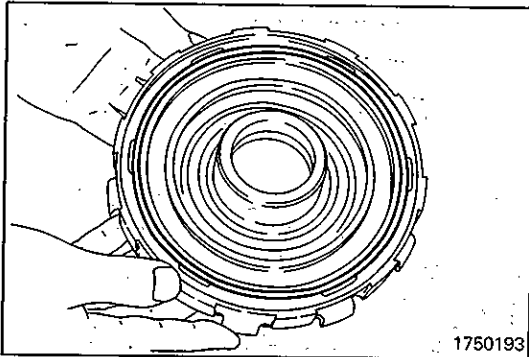

20. Apply a coating of petrolatum jelly to the wave spring and attach it to the center support.

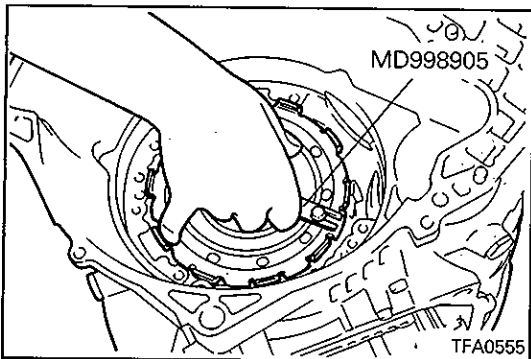

21. Mount the special tool on the center support, install 2 new O-rings on the support and push it into the transmission case.

Caution

1. Coat the O-rings with automatic transmission fluid and align the oil holes.
2. Do not move the wave spring out of position when installing.

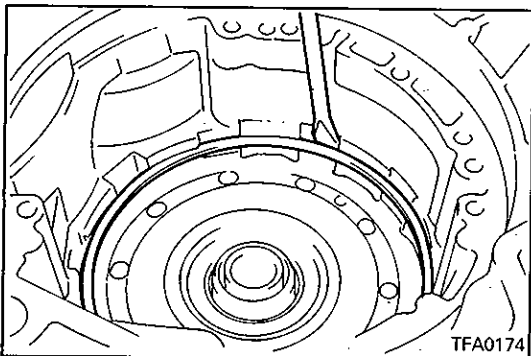

22. Install the snap ring.

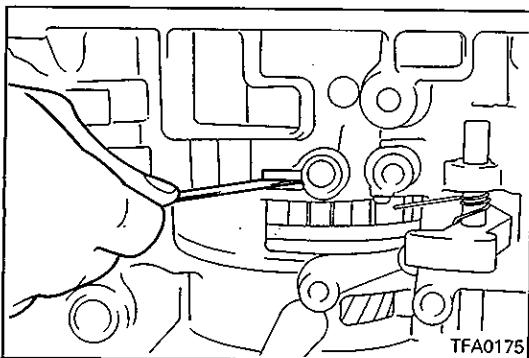

23. Use a thickness gauge and measure the end play of the low/reverse brake. If necessary, adjust to the standard value by selecting a pressure plate of proper thickness.

Standard value: 1.0 – 1.2 mm (0.039 – 0.047 in.)

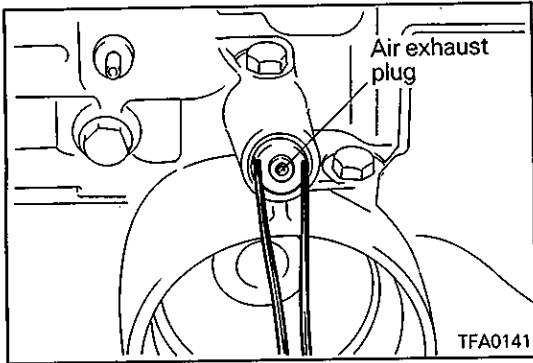

24. Install the air exhaust plug, and then install the plug.
Air exhaust plug: 33 Nm (3.3 kgm, 24 ft.lbs.)

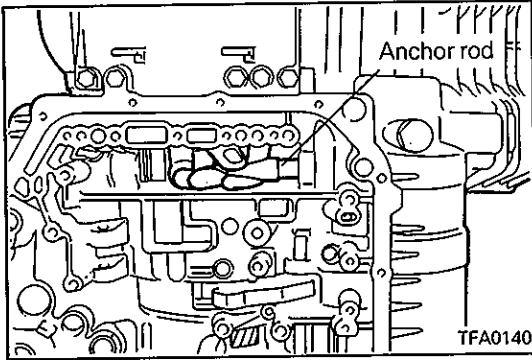

25. Install the anchor rod.

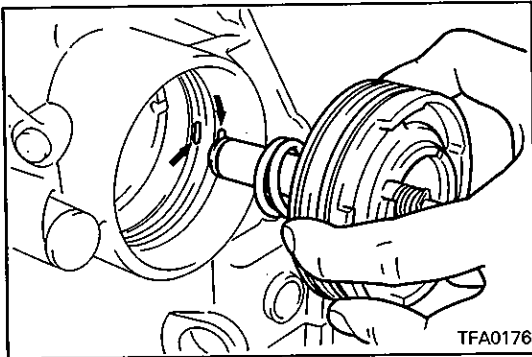

26. Install the kickdown servo spring, piston and sleeve.

Caution

- The seal ring alignment hole in the kickdown servo piston must not overlap the oil filler ports (indicated by the arrows in the diagram).

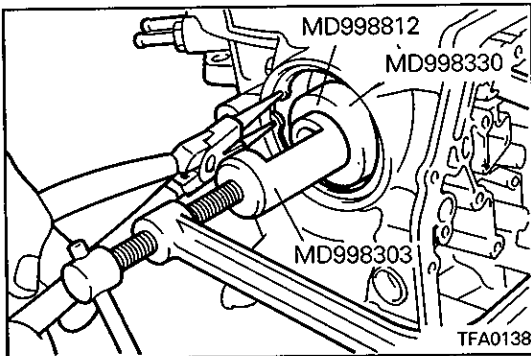

27. Use the special tool to hold the kickdown servo piston and sleeve pressed, and install the snap ring.

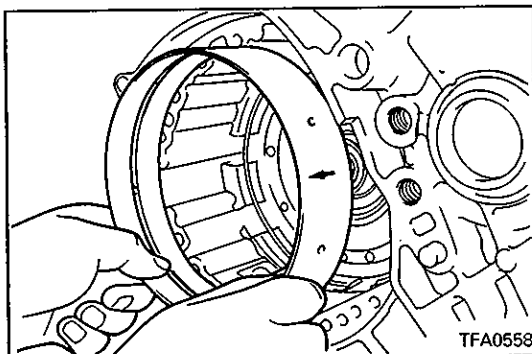

28. Install the kickdown band.

Caution

- Install with the arrow mark pointing to the front.

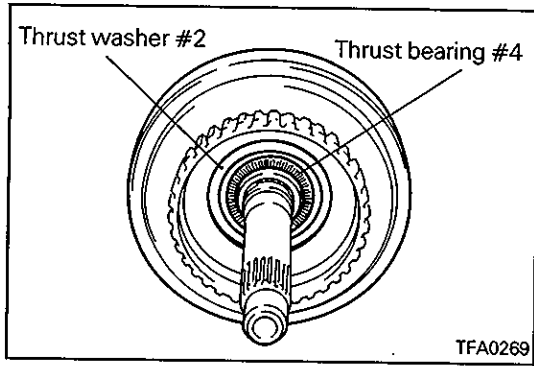

29. Install thrust bearing #4 and thrust washer #2 on the rear clutch.

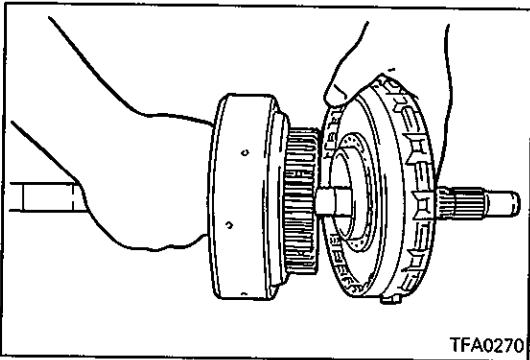

30. Combine the rear clutch assembly and the front clutch assembly.

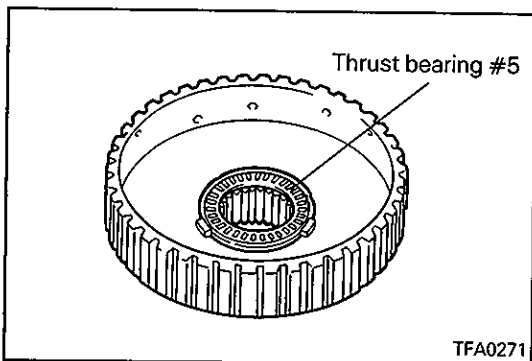

31. Install thrust bearing #5 on the rear clutch hub.

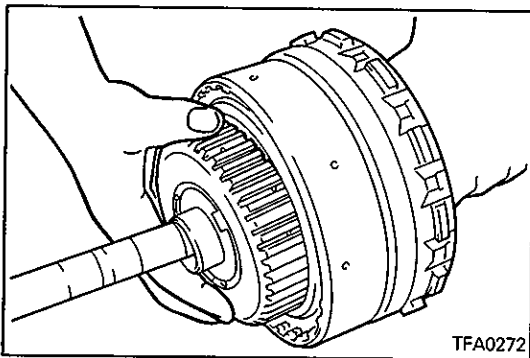

32. Install the rear clutch hub on the rear clutch.

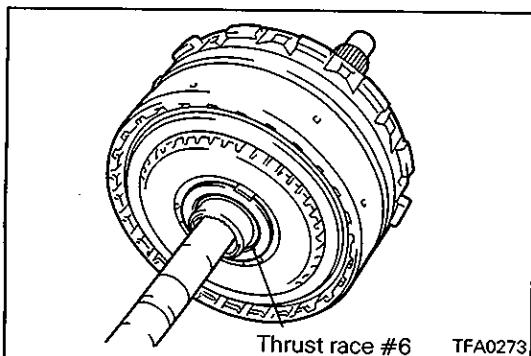

33. Install thrust race #6 on the end of the rear clutch hub.

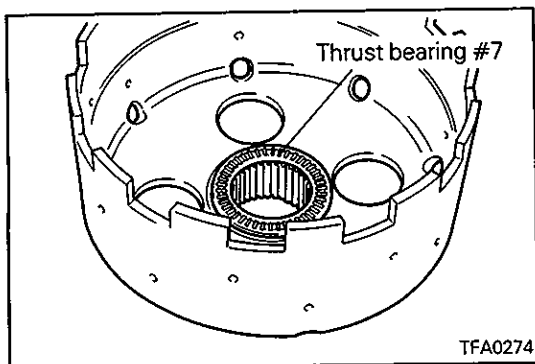

34. Install thrust bearing #7 in the kickdown drum.

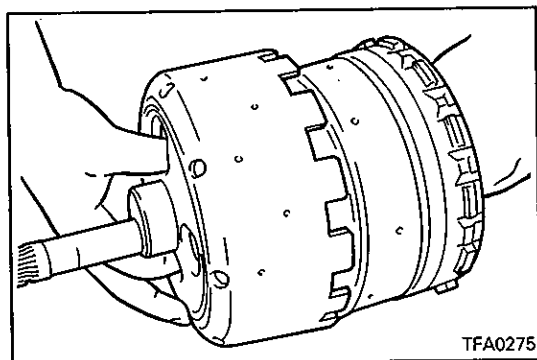

35. Assemble the clutch assembly in the kickdown drum.

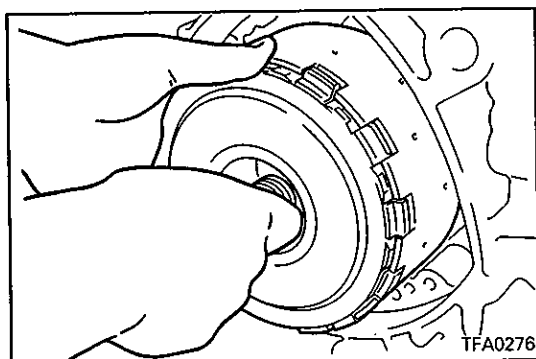

36. Install the assembled clutch assembly and kickdown drum into the transmission case.

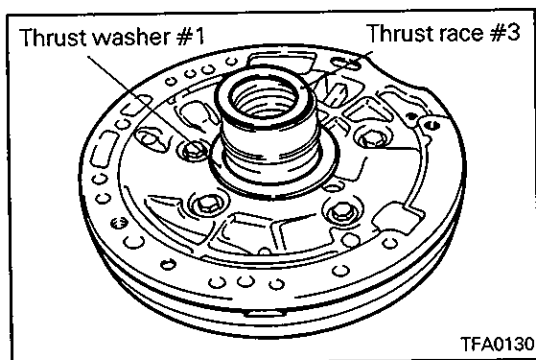

37. Install thrust race #3 and thrust washer #1 on the back of the oil pump using petrolatum jelly to hold them in place.

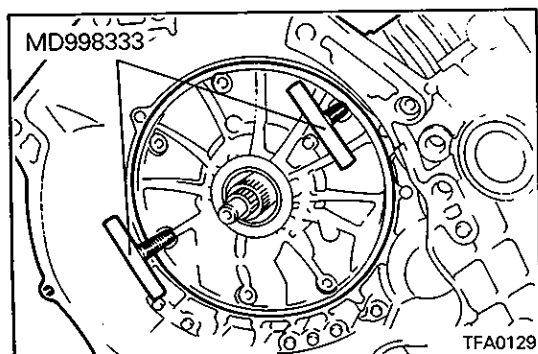

38. Use the special tool to install the oil pump assembly with a new gasket.

**Oil pump assembly mounting bolts:
21 Nm (2.1 kgm, 16 ft.lbs.)**

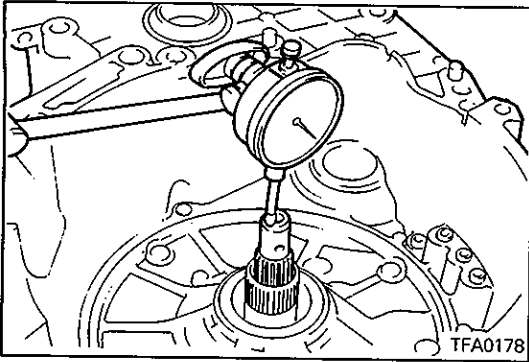

39. Measure the end play of the input shaft. If necessary, replace thrust race #3 and thrust washer #1 with ones of proper thickness to adjust to the standard value.

Standard value: 0.3 – 1.0 mm (0.012 – 0.039 in.)

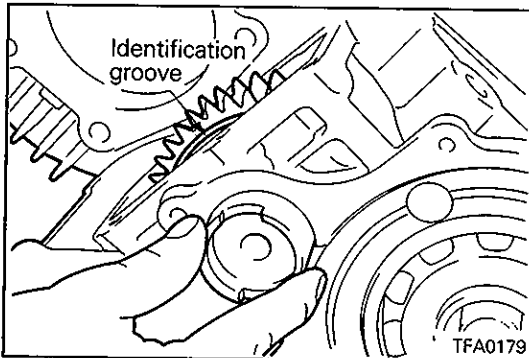

40. Install the spacer, the idler gear and the bearing and then insert the idler shaft. Assemble with the identification groove on the idler gear facing the rear.

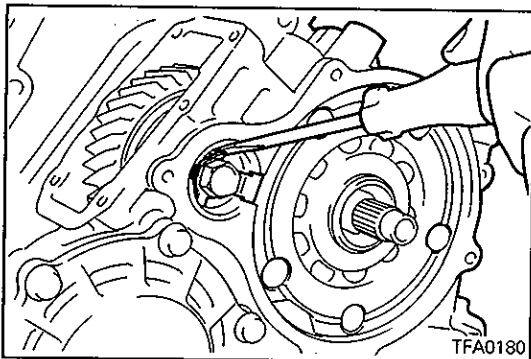

41. Tighten the idler shaft lock bolt to the specified torque with a new lock plate placed under the bolt head. Bend the 3 lugs of the lock plate to prevent the bolt from turning.

Idler shaft lock bolt: 38 Nm (3.8 kgm, 28 ft.lbs.)

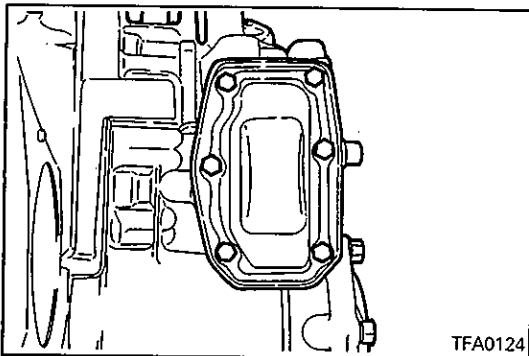

42. Install the idler gear cover with a new gasket.

**Idler gear cover mounting bolts:
11 Nm (1.1 kgm, 8 ft.lbs.)**

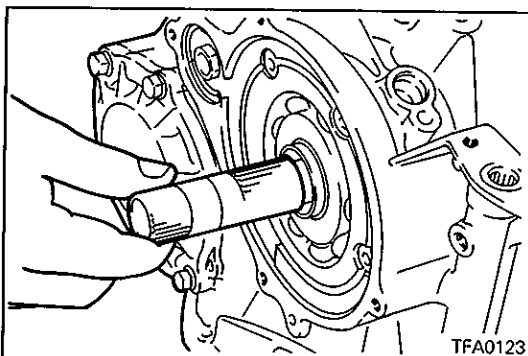

43. Install the end clutch shaft, first inserting the end with longer splines.

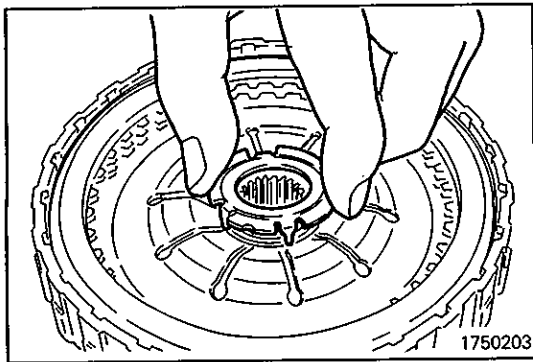

44. Fit the thrust washer on the return spring of the end clutch.

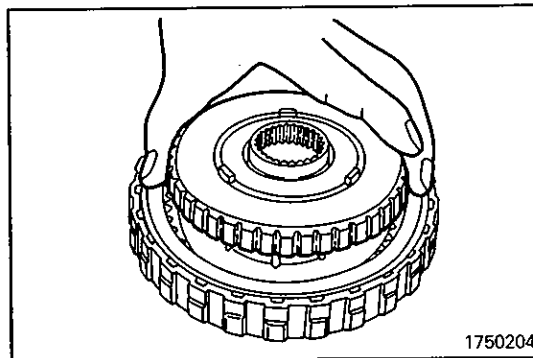

45. Install the end clutch hub on the end clutch assembly.

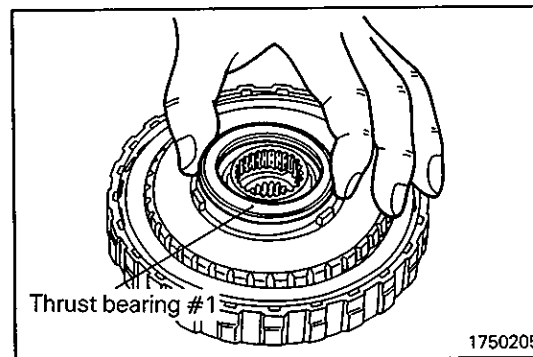

46. Install thrust bearing #1 to the end of the clutch hub using petrolatum jelly to hold it in place.

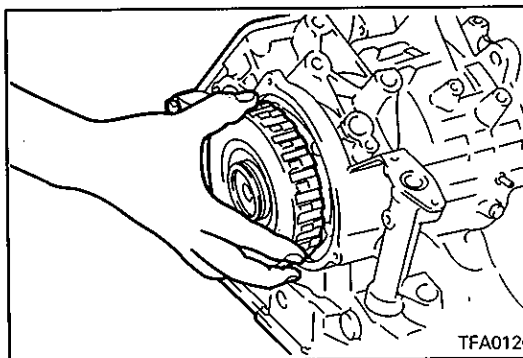

47. Install the end clutch assembly.

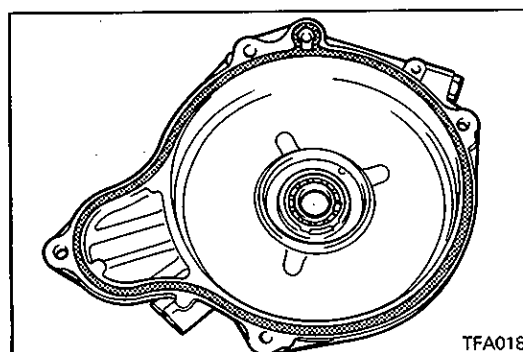

48. Attach a new O-ring to the end clutch cover.

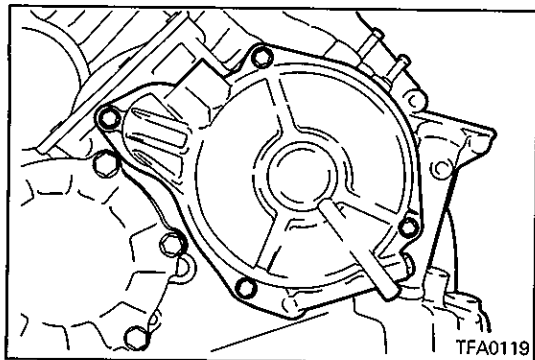

49. Install the end clutch cover and tighten the bolts to the specified torque.

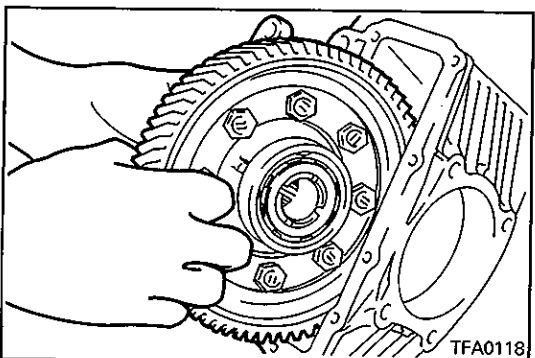

50. Install the differential assembly.

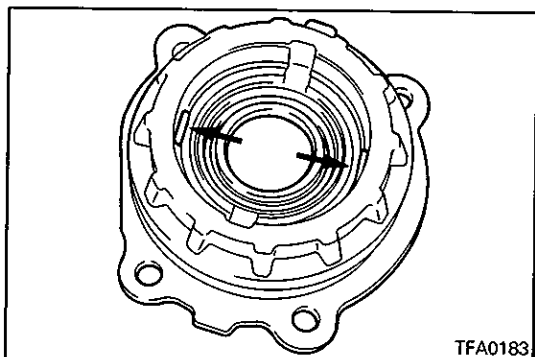

51. Place two pieces of approx. 10 mm (0.39 in.) long, 1.6 mm (0.06 in.) diameter solder on the differential rear bearing retainer at the positions shown in the diagram and install the outer race.

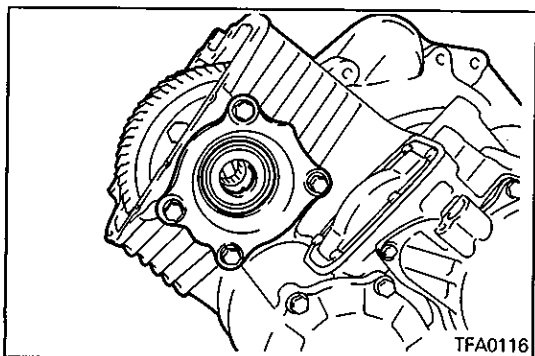

52. Install the differential rear bearing retainer and tighten the bolts to the specified torque.
 53. Loosen the bolts, remove the differential rear bearing retainer and remove the solder. If the solder is not crushed, repeat steps 51 – 52, using a 3 mm (0.12 in.) diameter solder.

**Differential rear bearing retainer mounting bolts:
 35 Nm (3.5 kgm, 26 ft.lbs.)**

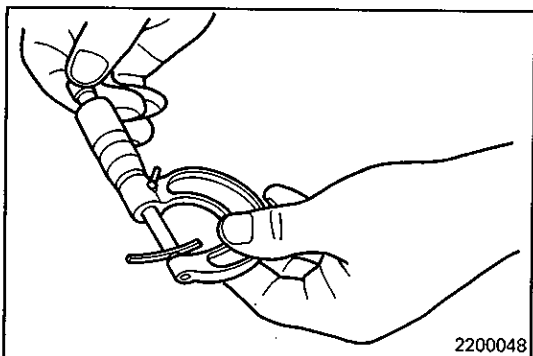

54. Measure the thickness of the crushed solder with a micrometer and adjust by selecting a spacer of the thickness that will ensure the standard end play and preload value.

Standard value: 0.075 – 0.135 mm (0.003 – 0.0053 in.)

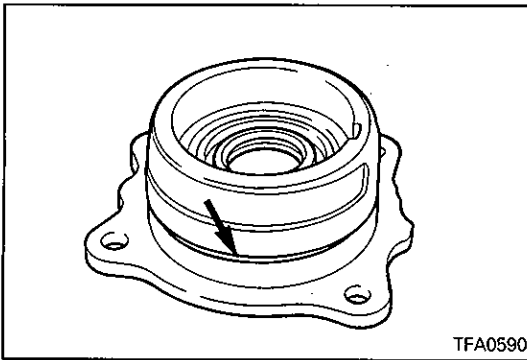

55. Install a new O-ring on the differential rear bearing retainer, coat the O-ring with automatic transmission fluid; then install the retainer in the transmission case and tighten the mounting bolts to the specified torque.

Differential rear bearing retainer mounting bolts:
35 Nm (3.5 kgm, 26 ft.lbs.)

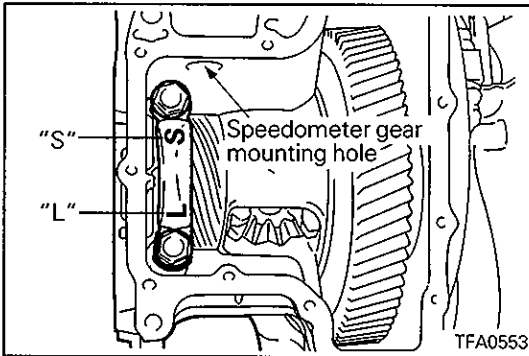

56. Install the front bearing cap and tighten the bolts to the specified torque. Use the shorter bolt on the "S" marked side and the longer one on the "L" marked side of the cap.

Differential front bearing cap mounting bolts:
70 Nm (7.0 kgm, 51 ft.lbs.)

57. Install the differential cover with a new gasket.

Differential cover mounting bolts:
11 Nm (1.1 kgm, 8 ft.lbs.)

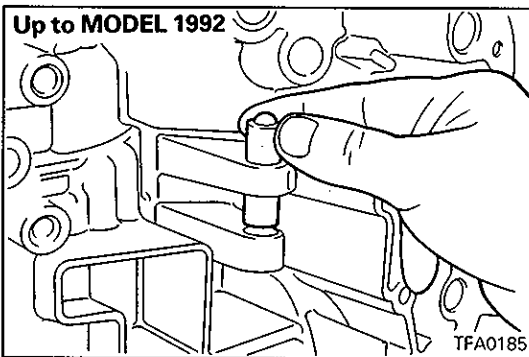

58. Install the detent assembly. <Up to MODEL 1992> or detent plate <MODEL 1993>

Detent spring mounting bolt <MODEL 1993>:
11 Nm (1.1 kgm, 8 ft.lbs.)

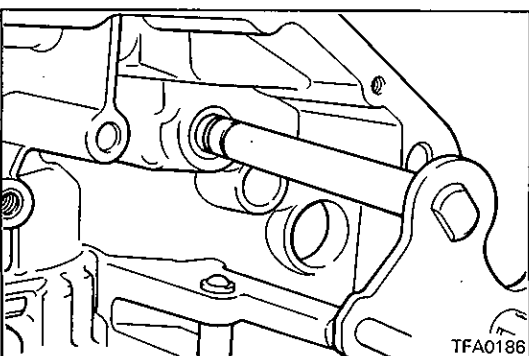
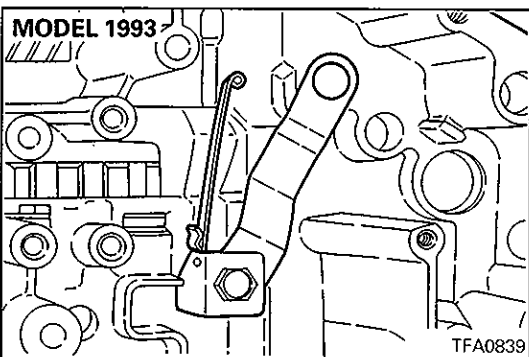

59. Install a new O-ring on the manual control shaft assembly, coat the O-ring with automatic transmission fluid and then insert the shaft assembly into the transmission case.
60. Align the groove in the manual control shaft and the set screw hole; then install the set screw.

Manual control shaft set screw:
9 Nm (0.9 kgm, 7 ft.lbs.)

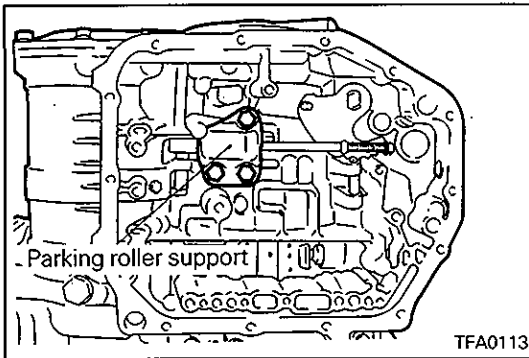

61. Install the parking roller support.

**Parking roller support bolts:
24 Nm (2.4 kgm, 18 ft.lbs.)**

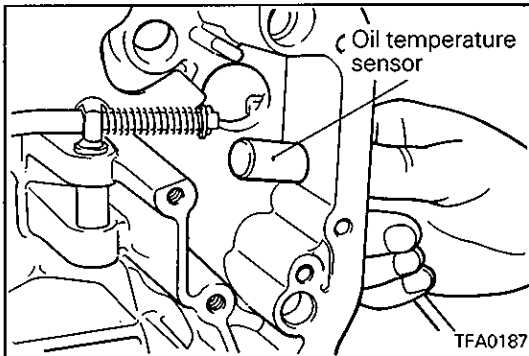

62. Insert the oil temperature sensor into the case.

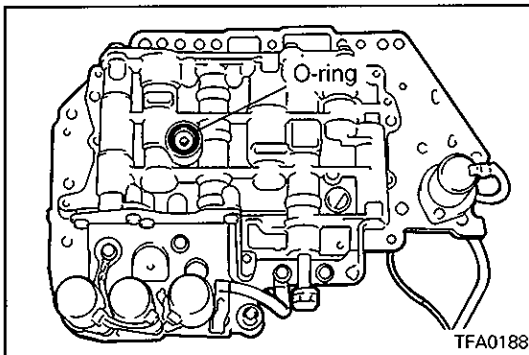

63. Install the O-ring in the O-ring groove at the top of the valve body assembly.

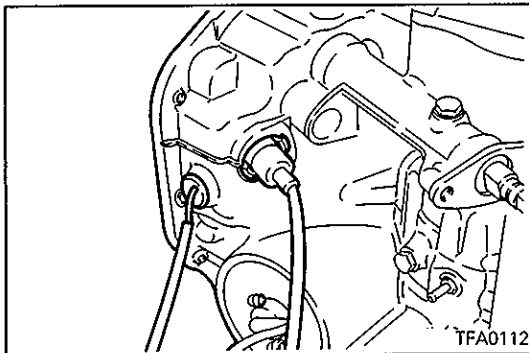

64. Replace the solenoid valve harness grommet O-ring with a new one.

65. Pass the solenoid valve connector through the hole in the transmission case from inside the case.

66. Push the solenoid valve harness grommet into the case hole.

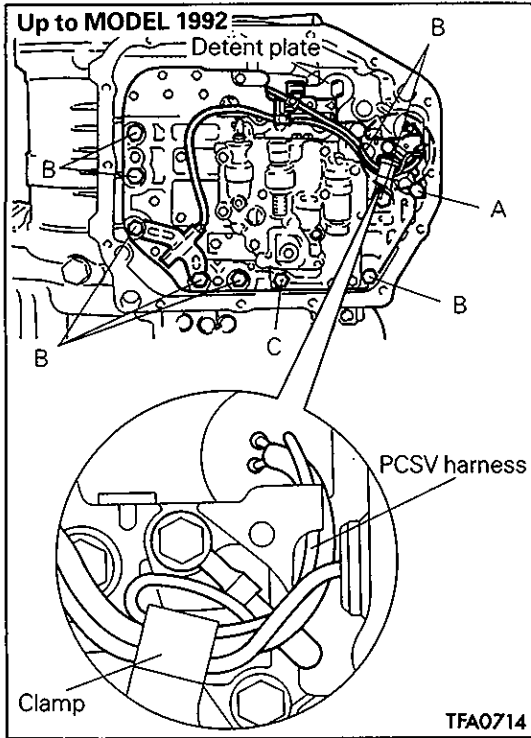

67. Insert the knock pin of the valve body into the case, keeping the detent plate pin in the manual valve groove. Temporarily install the valve body, install the oil temperature sensor and holder; then tighten the mounting bolts to the specified torque.

A bolt: 18 mm (0.709 in.)

B bolt: 25 mm (0.984 in.)

C bolt: 40 mm (1.575 in.)

Valve body assembly mounting bolts:
11 Nm (1.1 kgm, 8 ft.lbs.)

Caution

- **Firmly fasten the solenoid valve and the oil temperature sensor harness at the position shown in the illustration.**

Especially, the pressure control solenoid valve (PCSV) harness, which is separated from other harness should be routed and clamped as shown in the illustration. Failure to fasten it may result in contact with the detent plate or parking rod.

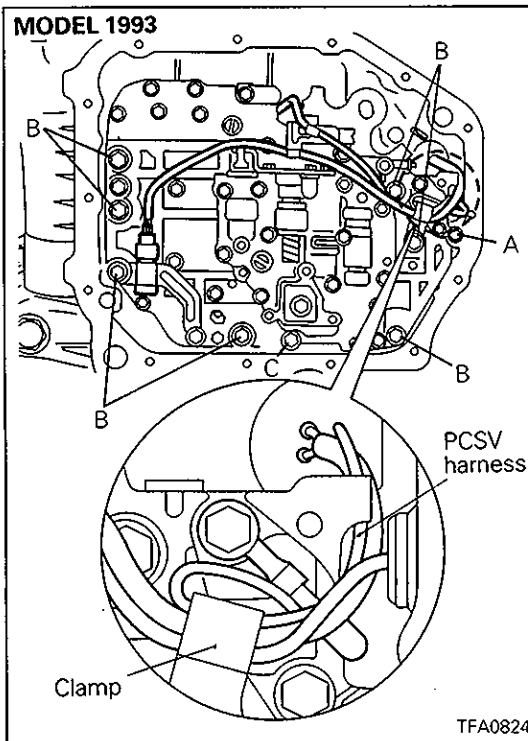

68. Install the oil screen.

Oil screen mounting bolts: 6 Nm (0.6 kgm, 5 ft.lbs.)

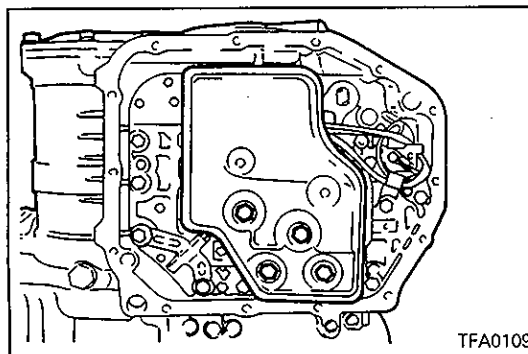

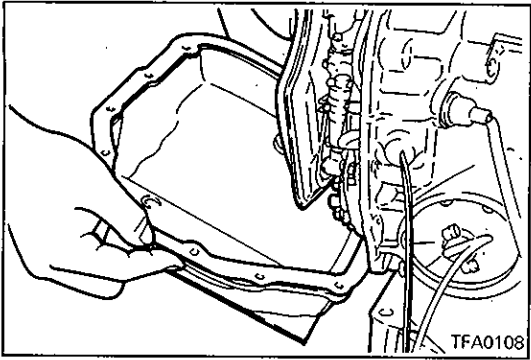

69. Install the magnets in the oil pan and install the oil pan.
Oil pan mounting bolts: 11 Nm (1.1 kgm, 8 ft.lbs.)

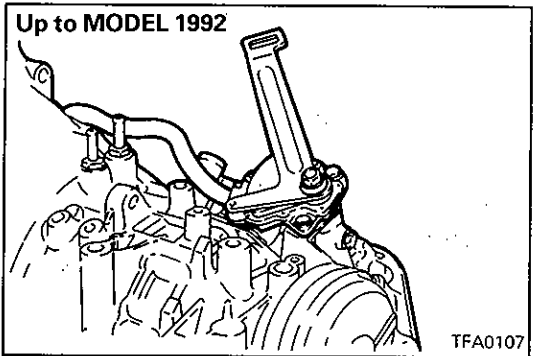

70. Install the inhibitor switch and the manual control lever.
Inhibitor switch mounting bolts: 11 Nm (1.1 kgm, 8 ft.lbs.)
Manual control lever mounting bolt: 19 Nm (1.9 kgm, 14 ft.lbs.)

71. Install the speedometer gear assembly.

Speedometer gear locking plate mounting bolt: 5 Nm (0.5 kgm, 4 ft.lbs.)

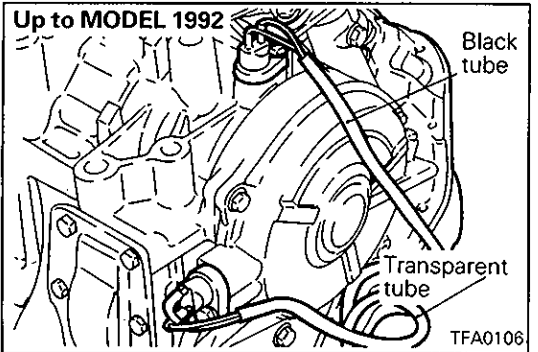
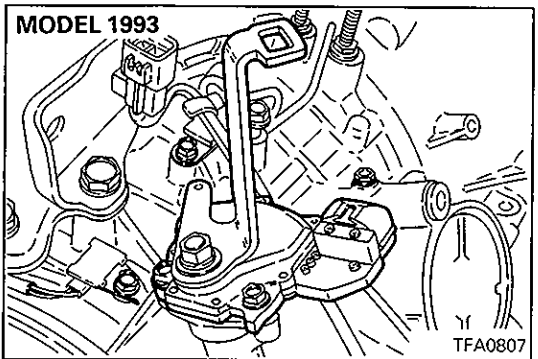

72. Install pulse generators A and B.

Pulse generator mounting bolts: 11 Nm (1.1 kgm, 8 ft.lbs.)

Caution

- Install the black tube on the output gear side and the transparent tube on the end clutch side.

73. Install the oil filler tube and insert the level gauge.

Oil filler tube mounting bolt: 24 Nm (2.4 kgm, 18 ft.lbs.)

74. Install the brackets.

Transmission mounting bracket bolts: 70 Nm (7.0 kgm, 51 ft.lbs.)

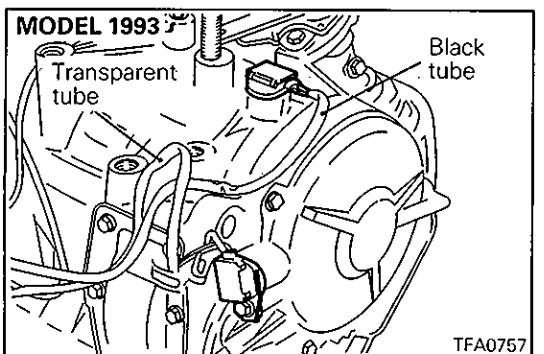

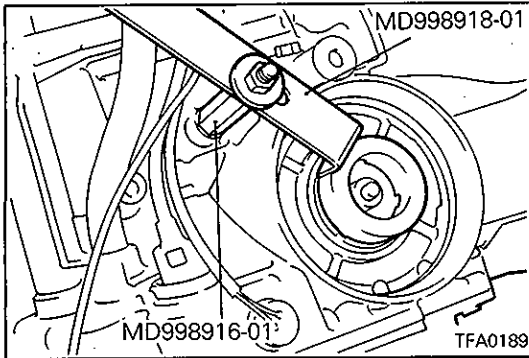

75. Adjust the kickdown servo by the following procedure:
- Fit the claw of the special tool in the notch of the piston to prevent the piston from turning, and use adapter to secure it as illustrated.

Caution

- Do not push the piston inward with the special tool.
- When the adapter is installed on the transmission case, do not apply excessive torque but only hand tighten it.

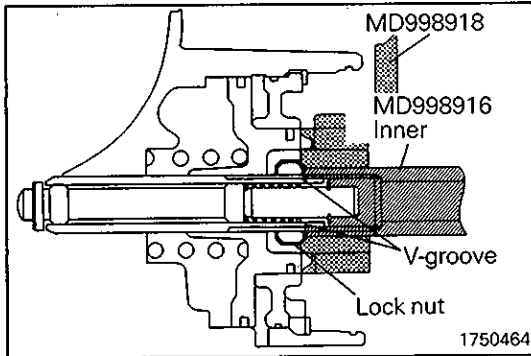

- Loosen the lock nut until it is about to reach the V groove in the adjusting rod. Install the special tool (inner) on the adjusting rod and turn down until it touches the lock nut.

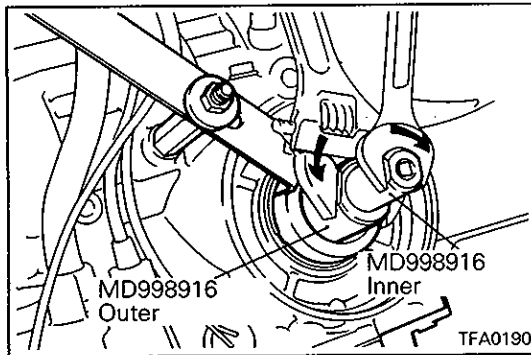

- Fit the special tool (outer) on the lock nut. Turn the outer tool counterclockwise and the inner tool clockwise to lock the lock nut against the inner tool.

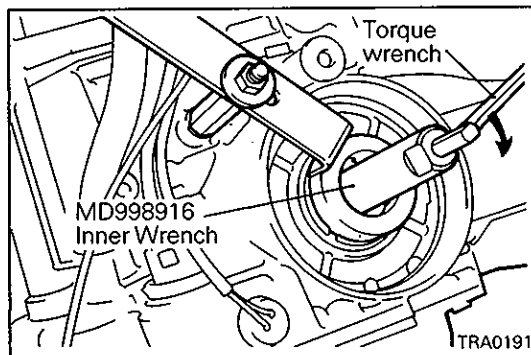

- Fit a torque wrench to the inner tool (inner) to tighten it to a torque of 10 Nm (1.0 kgm, 7.2 ft.lbs.) and loosen. Repeat this sequence two times before finally tightening the inner tool finally to 5 Nm (0.5 kgm, 3.6 ft.lbs.) torque. Then back off the outer tool 2 to 2¼ turns.

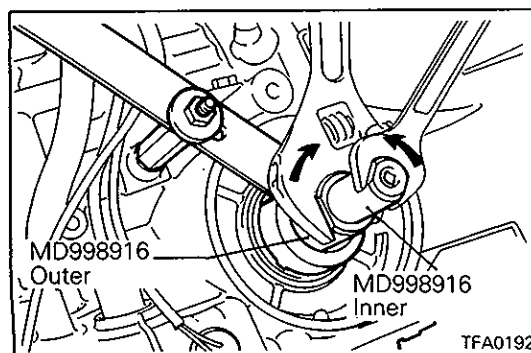

- Turn the outer tool clockwise and the inner tool counterclockwise to separate the lock nut from the inner tool.

Caution

- When doing this work, apply equal force to both tools.

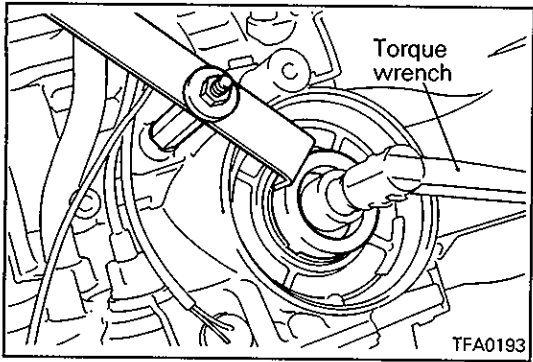

- (f) Hand tighten the lock nut until it touches the piston. Then, use a torque wrench to tighten the lock nut to the specified torque.

Lock nut: 29 Nm (2.9 kgm, 21 ft.lbs.)

Caution

- The lock nut may turn with the adjusting rod if tightened too quickly.

- (g) Remove the special tool that secures the piston. Install the plug to the Low/Reverse pressure outlet and tighten it to the specified torque.

76. Install the kickdown servo switch and secure with the snap ring.

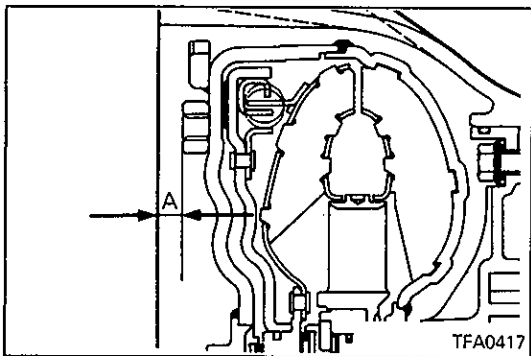
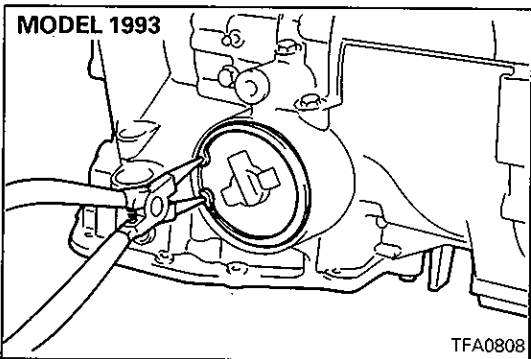
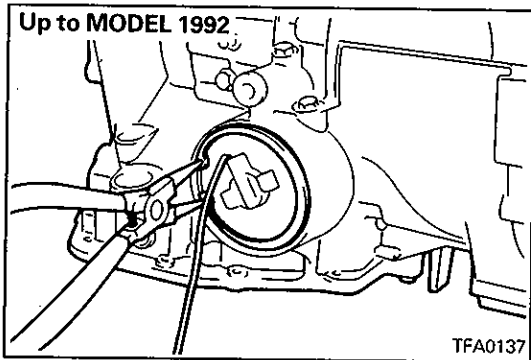

77. Coat the oil pump drive hub with automatic transmission fluid and install the torque converter. Push in firmly so that dimension A in the diagram is the standard value.

Standard value: approx. 16.3 mm (0.642 in.)

4. TRANSMISSION (W4A32, W4A33)

COMPONENTS

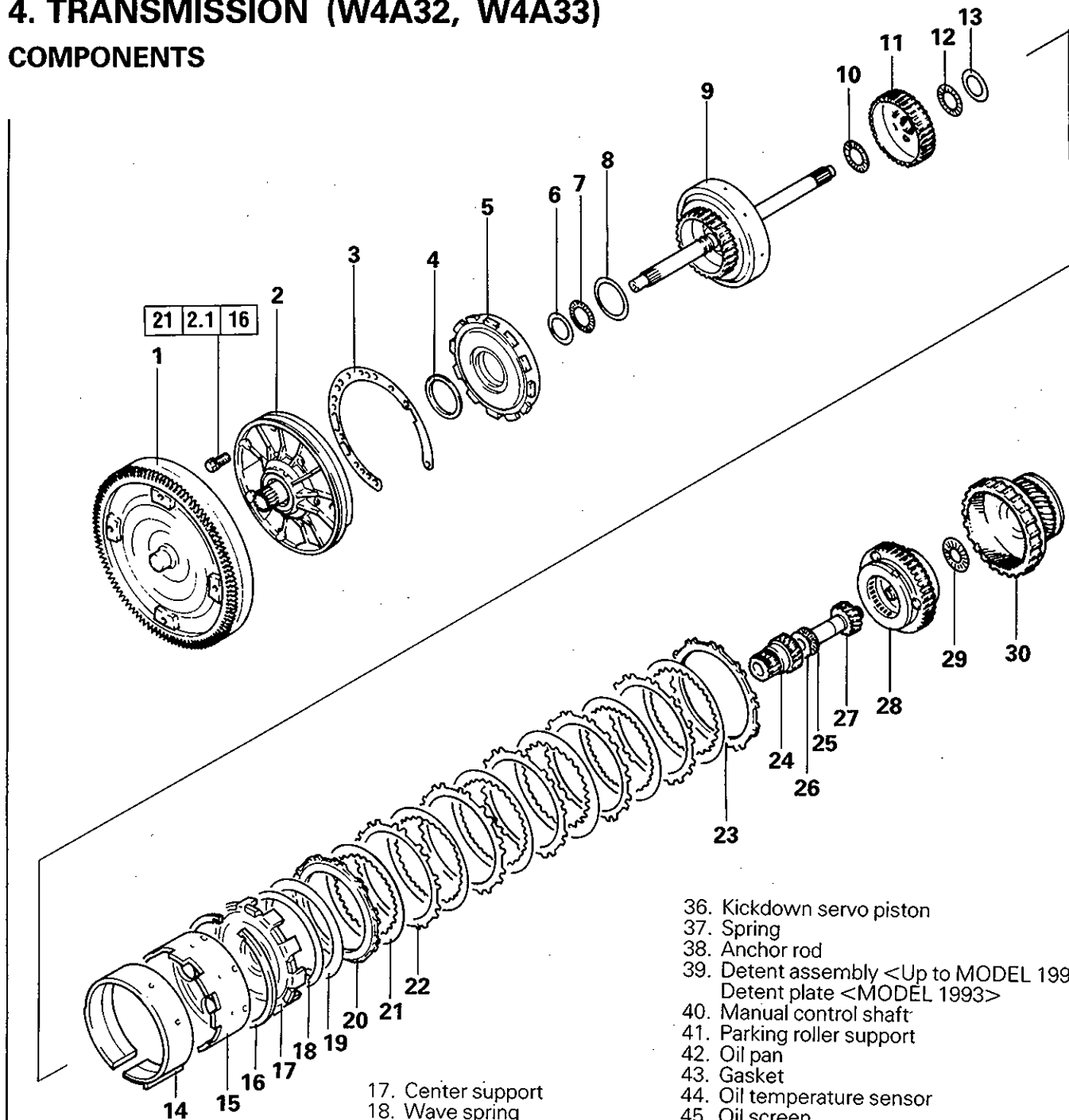

- 1. Torque converter
- 2. Oil pump assembly
- 3. Gasket
- 4. Thrust washer #1
- 5. Front clutch assembly
- 6. Thrust race #3
- 7. Thrust bearing #4
- 8. Thrust washer #2
- 9. Rear clutch assembly
- 10. Thrust bearing #5
- 11. Rear clutch hub
- 12. Thrust race #6
- 13. Thrust bearing #7
- 14. Kickdown band
- 15. Kickdown drum
- 16. Snap ring

- 17. Center support
- 18. Wave spring
- 19. Return spring
- 20. Pressure plate
- 21. Brake disc
- 22. Brake plate
- 23. Reaction plate
- 24. Reverse sun gear
- 25. Thrust bearing #8
- 26. Thrust race #9
- 27. Forward sun gear
- 28. Planetary carrier assembly
- 29. Thrust bearing #10
- 30. Output flange
- 31. Oil level gauge
- 32. Oil filler tube
- 33. Snap ring
- 34. Kickdown servo switch
- 35. Snap ring

- 36. Kickdown servo piston
- 37. Spring
- 38. Anchor rod
- 39. Detent assembly <Up to MODEL 1992>
Detent plate <MODEL 1993>
- 40. Manual control shaft
- 41. Parking roller support
- 42. Oil pan
- 43. Gasket
- 44. Oil temperature sensor
- 45. Oil screen
- 46. Valve body assembly
- 47. Manual control lever
- 48. Inhibitor switch
- 49. End clutch shaft
- 50. Bearing retainer
- 51. Thrust bearing #11
- 52. End clutch hub
- 53. Thrust washer
- 54. End clutch assembly
- 55. O-ring
- 56. End clutch cover
- 57. Pulse generator
- 58. Lock bolt
- 59. Idler shaft
- 60. Idler gear
- 61. Spacer
- 62. Gasket

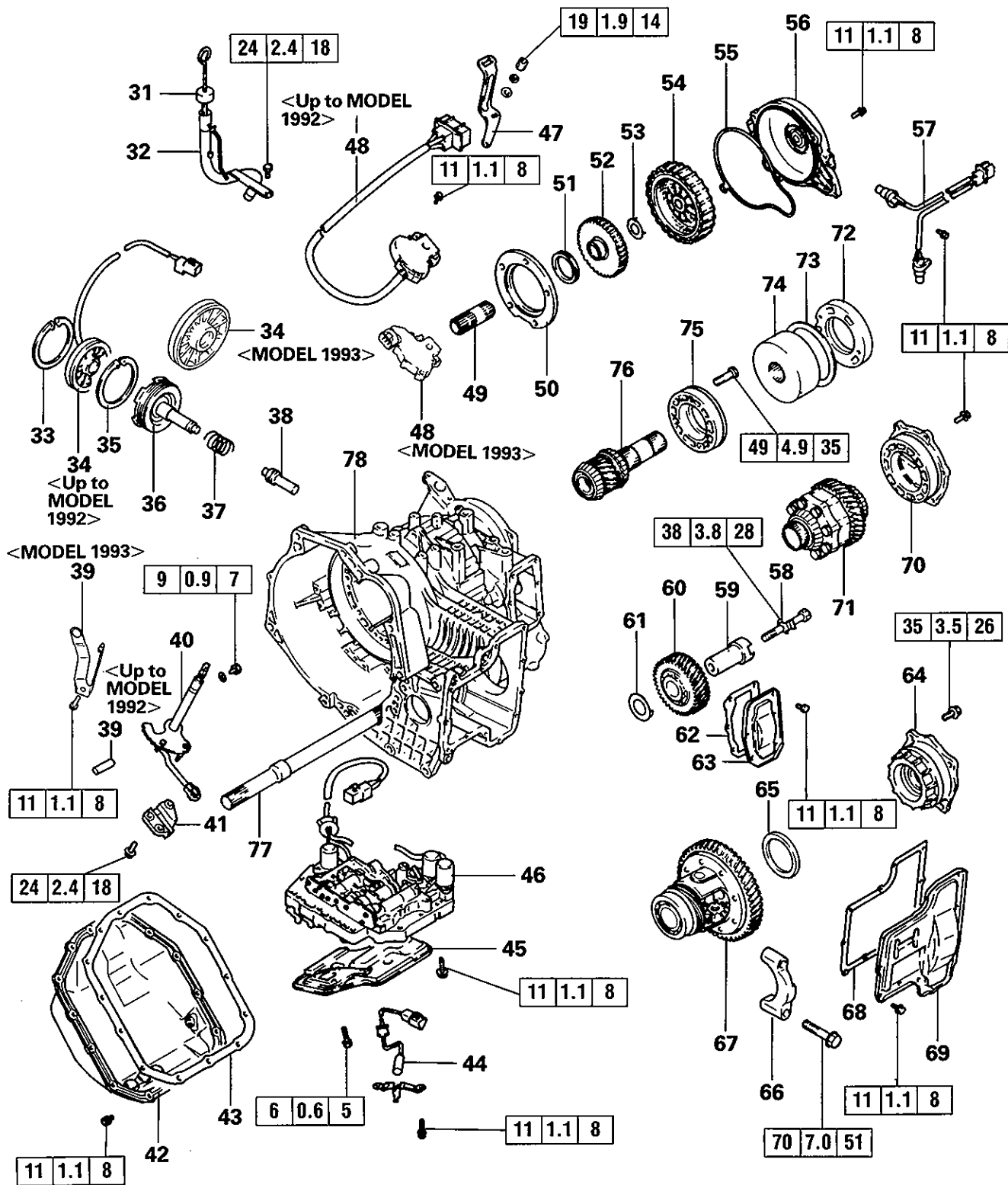

- 63. Idler gear cover
- 64. Differential bearing retainer
- 65. Spacer
- 66. Differential front bearing cap
- 67. Differential assembly
- 68. Gasket
- 69. Differential cover
- 70. Outer bearing retainer

- 71. Center differential assembly
- 72. Center bearing retainer
- 73. Stopper ring
- 74. Viscous coupling unit
- 75. Center bearing retainer
- 76. Front output shaft
- 77. Rear output shaft
- 78. Transmission case

TFA0997

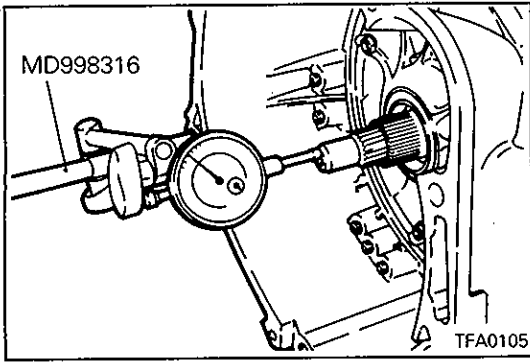

DISASSEMBLY

1. Clean away any sand, mud, etc. if present around the transmission.
2. Place the transmission assembly on the workbench with the oil pan down.
3. Remove the torque converter.
4. Use the special tool to mount the dial gauge on the transmission case and measure the end play of the input shaft.
5. Remove pulse generators "A" and "B".

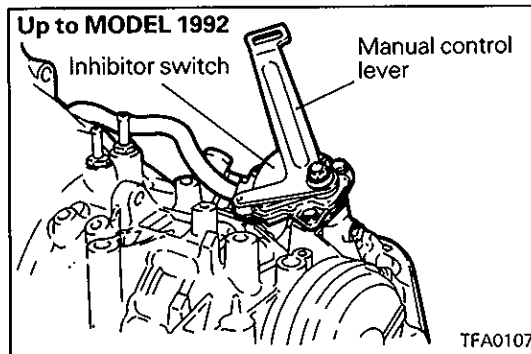
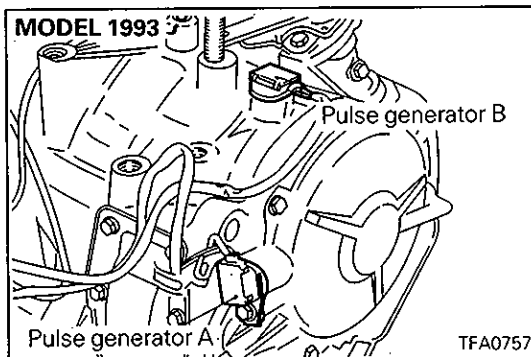
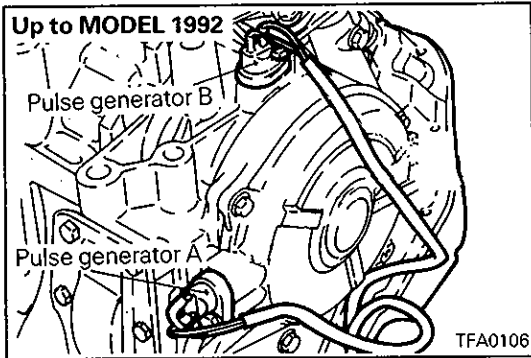

6. Remove the manual control lever, then remove the inhibitor switch.

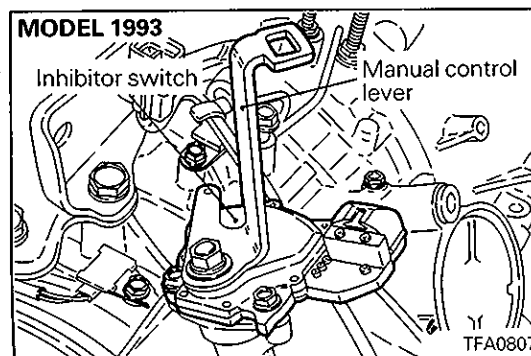

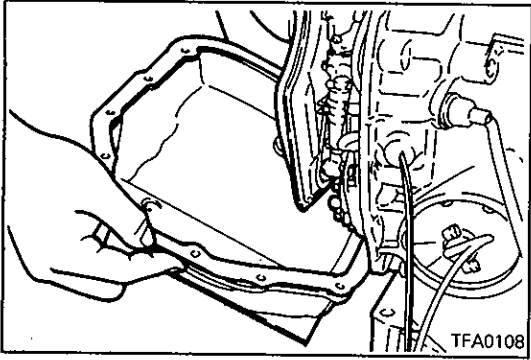

7. Remove the oil pan, the magnets and the gasket.

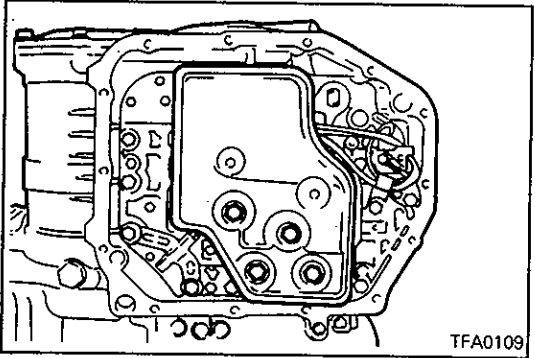

8. Remove the oil filter from the valve body.

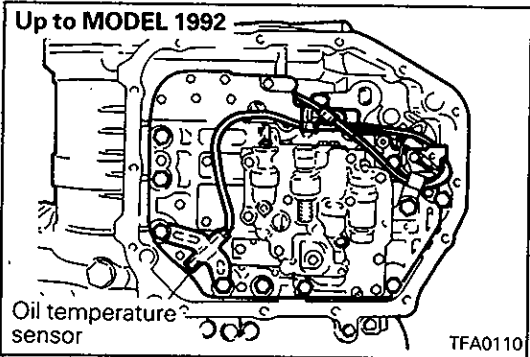

9. Remove the valve body mounting bolts at 10 places.
 10. Remove the oil temperature sensor holder and unclamp the oil temperature sensor harness.

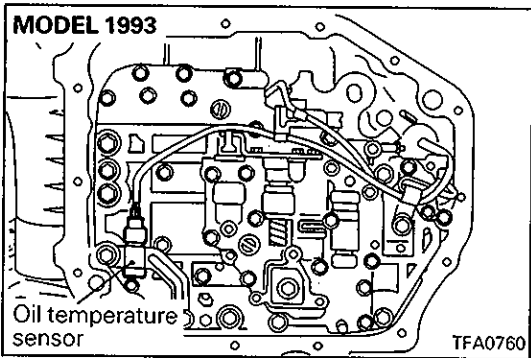

11. Press the finger of the solenoid valve harness grommet, push the grommet into the case and remove the valve body assembly.
 12. Pull out the oil temperature sensor.

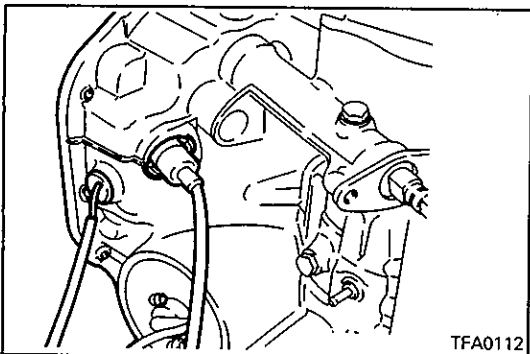

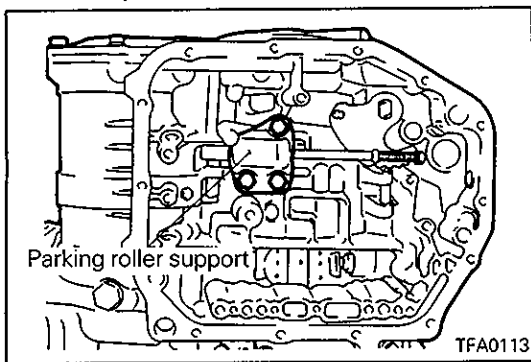

13. Remove the parking roller support.

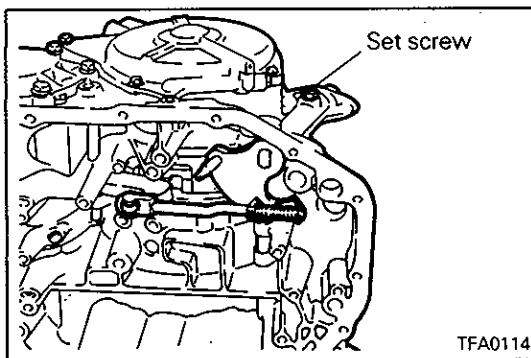

14. Remove the set screw of the manual control shaft and remove the manual control shaft assembly.
15. Remove the detent assembly.

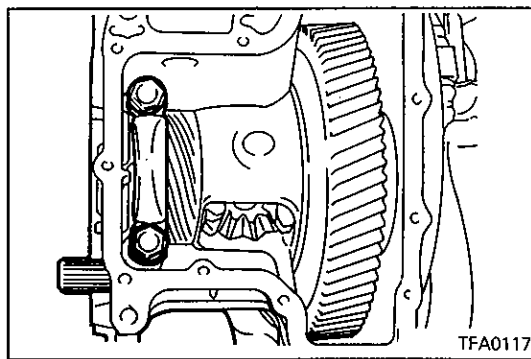

16. Remove the differential cover and the gasket.
17. Remove the differential front bearing cap.

Intentionally blank

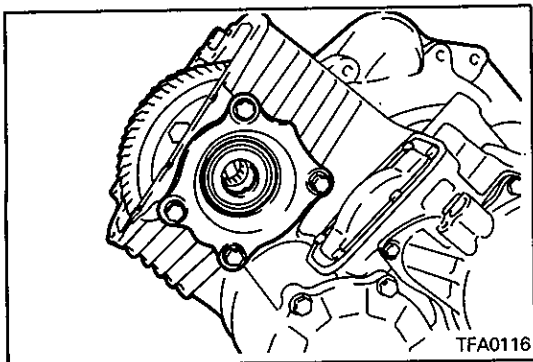

18. Remove the differential bearing retainer, the spacer and the outer race.

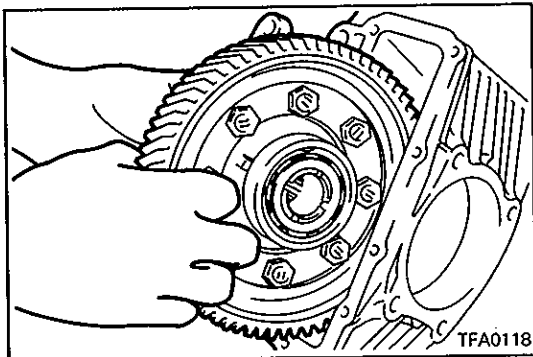

19. Remove the differential assembly.

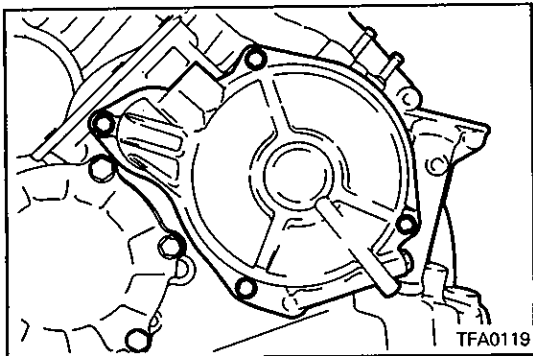

20. Remove the end clutch cover mounting bolts, then remove the cover holder and end the clutch cover.

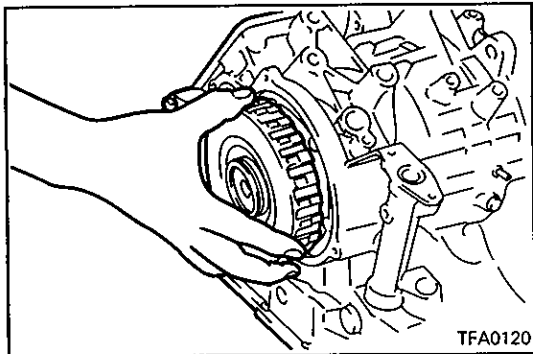

21. Remove the end clutch assembly.

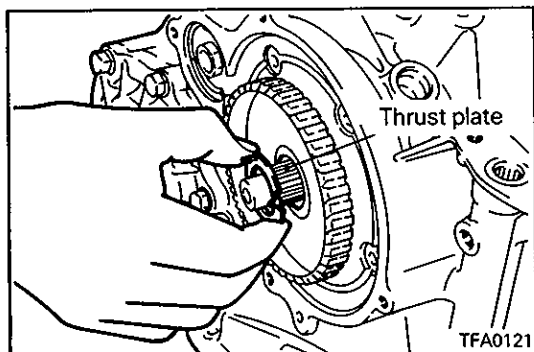

22. Remove the thrust plate.

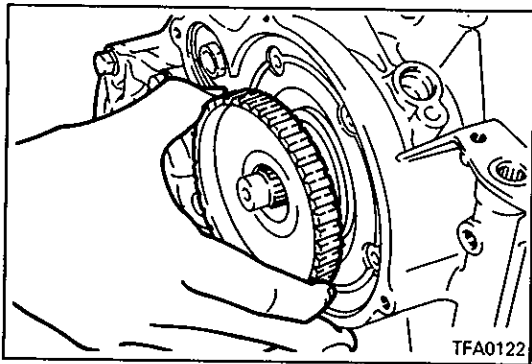

23. Remove the end clutch hub.
24. Remove thrust bearing #11.

NOTE

The thrust bearing may be stuck to the end clutch hub.

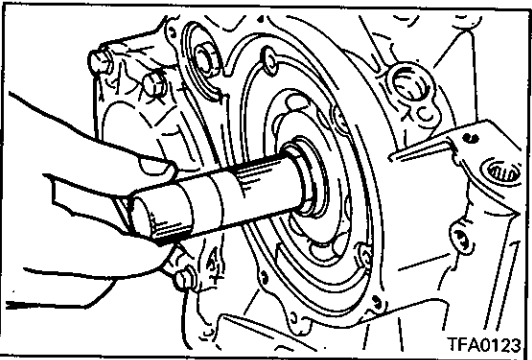

25. Pull out the end clutch shaft.

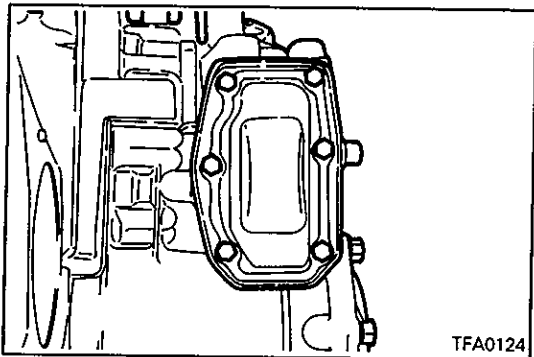

26. Remove the idler gear cover mounting bolts, then remove the idler gear cover and the gasket.

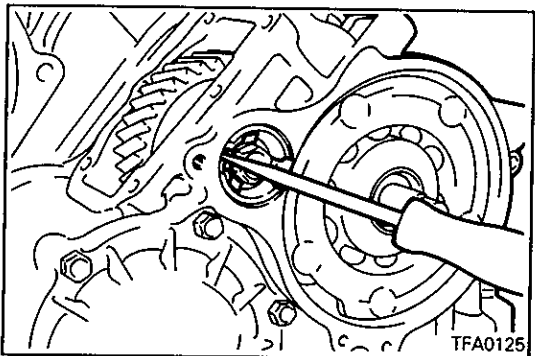

27. Disengage the bolt stopper and remove the bolt.

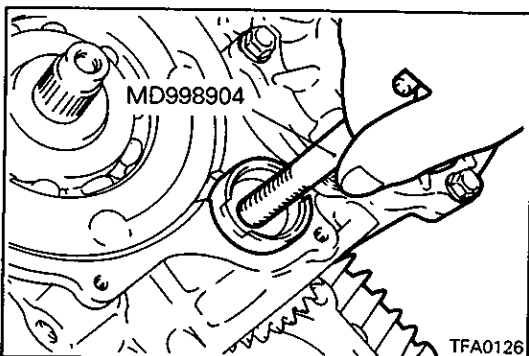

28. Using the special tool, pull out the idler shaft and then remove the idler gear and the bearing inner race.

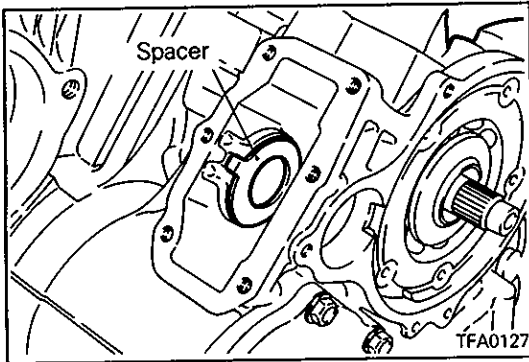

29. Remove the spacer.

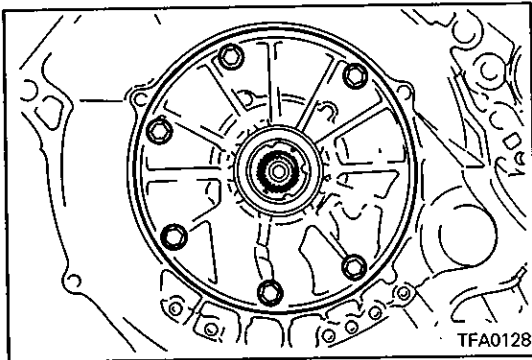

30. Remove the oil pump mounting bolts.

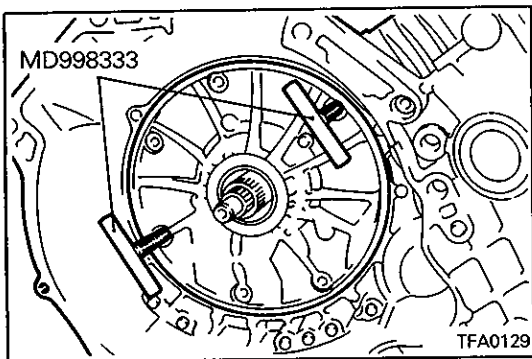

31. Use the special tool to remove the oil pump.

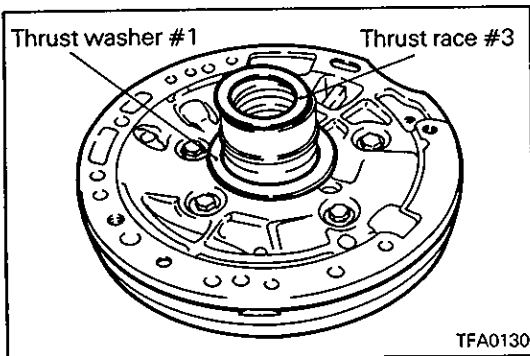

32. Remove thrust washer #1 and thrust race #3.

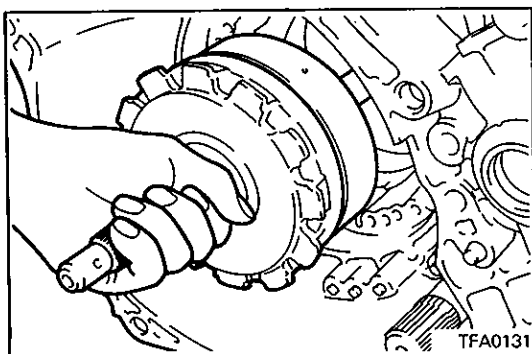

33. Hold the input shaft and remove the front and rear clutch assemblies together.

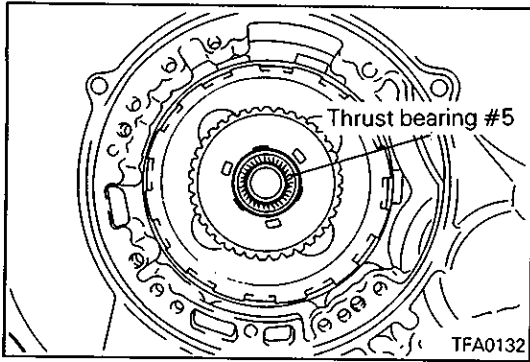

34. Remove thrust bearing #5.

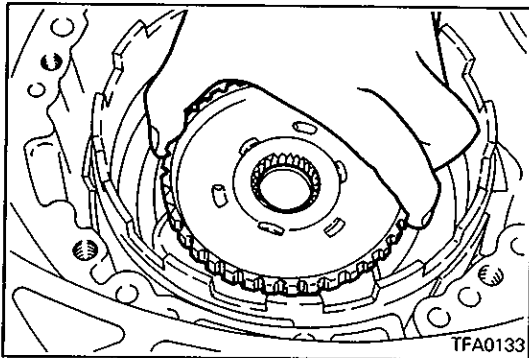

35. Remove the clutch hub.

NOTE

The thrust race may be stuck to the clutch hub.

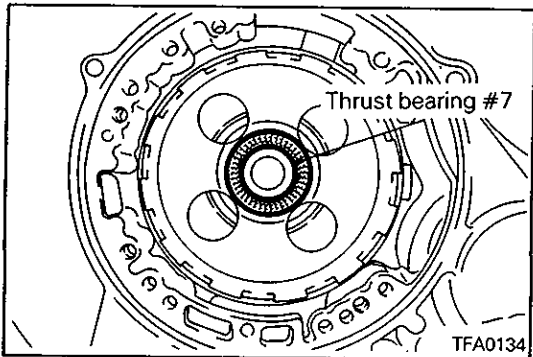

36. Remove thrust bearing #7.

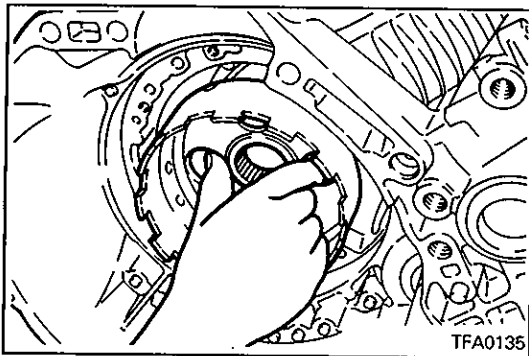

37. Remove the kickdown drum.

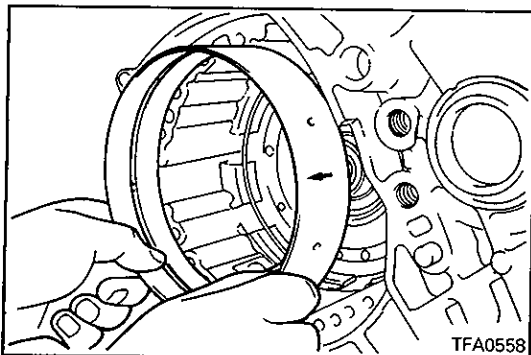

38. Remove the kickdown band.

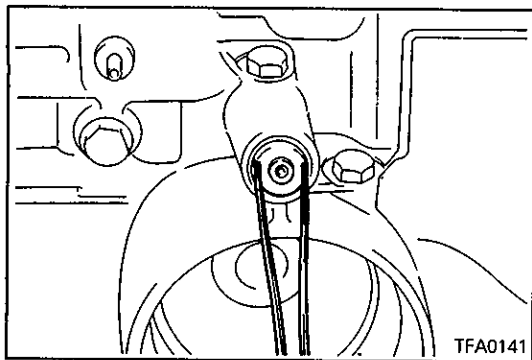

43. Remove the plug, then remove the air exhaust plug.

Intentionally blank

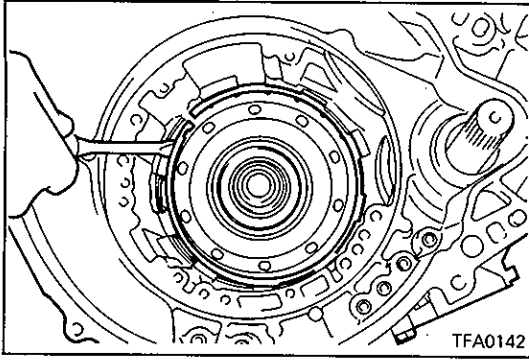

44. Remove the snap ring.

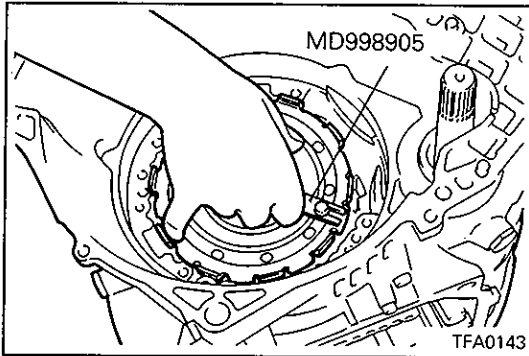

45. Using the special tool, remove the center support.

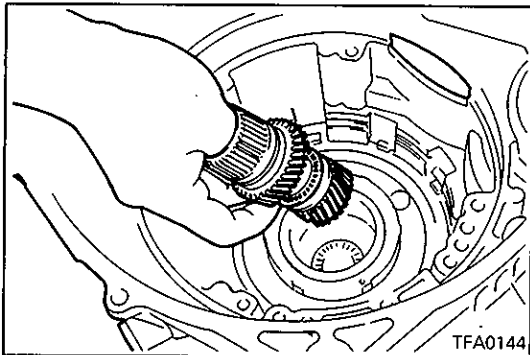

46. Remove the reverse and forward sun gears together.

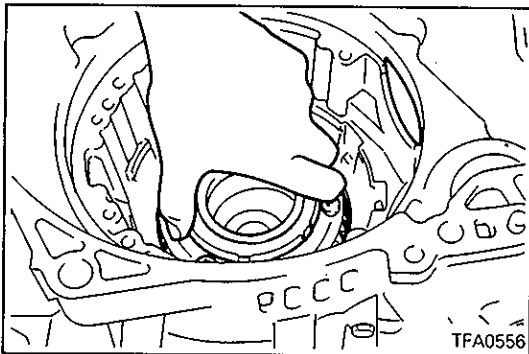

47. Remove the planet carrier assembly.

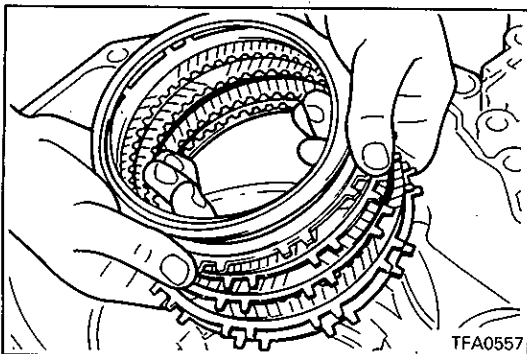

48. Remove the wave spring, return spring, reaction plate, brake discs, and brake plates.

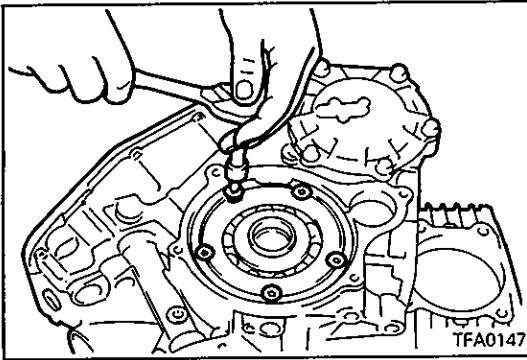

49. Remove the screws and the rear bearing retainer.

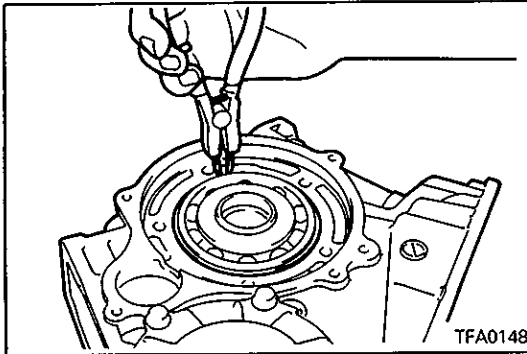

50. Remove the snap ring and then remove the output flange assembly.

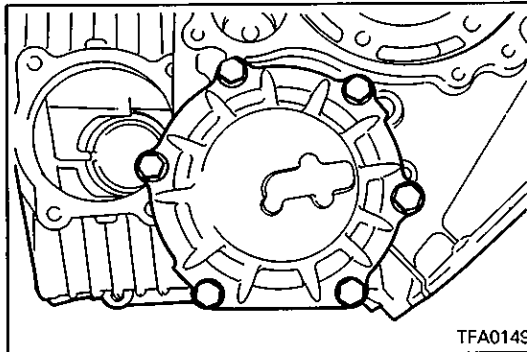

51. Remove the output bearing retainer mounting bolts and then remove the output bearing retainer and outer race.

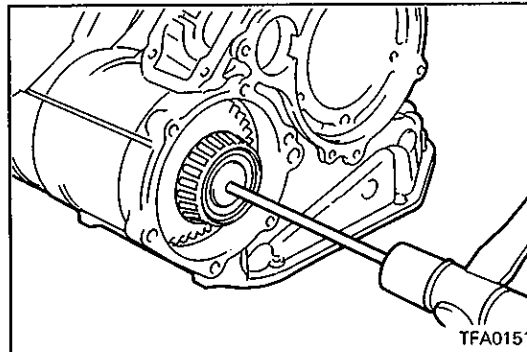

52. Insert an 8 mm (0.31 in.) diameter and 200 mm (7.87 in.) long rod in the hole shown in the figure and drive out the rear output shaft.

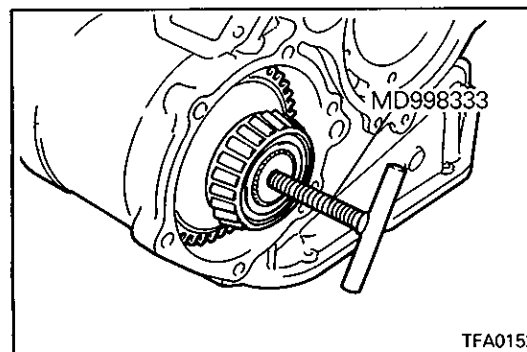

53. Using the special tool, remove the center differential.

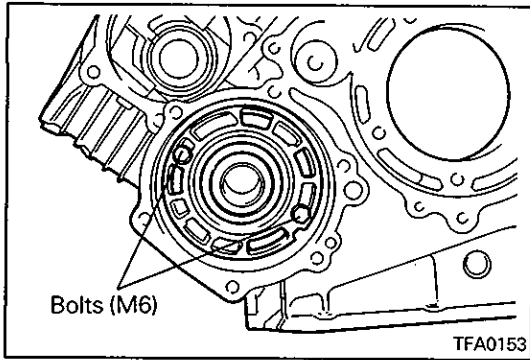

54. Attach two M6 bolts to the center bearing retainer and, holding these bolts, remove the center bearing retainer and outer race.

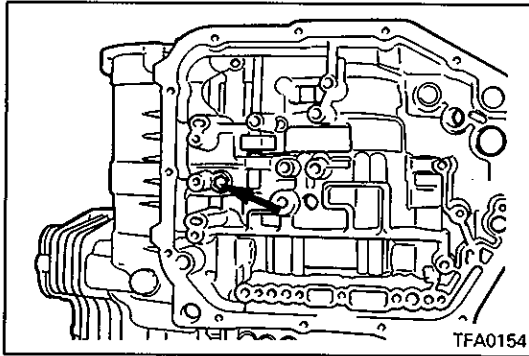

55. Remove the center bearing retainer stopper bolt.

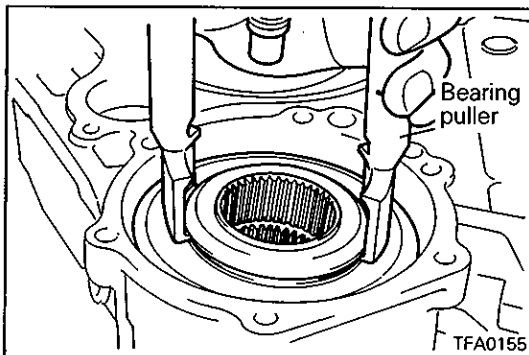

56. Remove the stopper ring. Put a bearing puller or similar tool in the viscous coupling groove and pull out the viscous coupling.

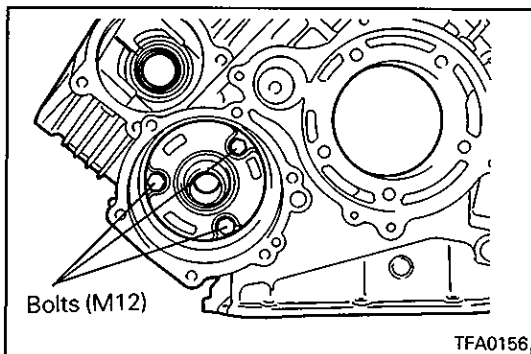

57. Remove the front bearing retainer mounting bolts (M10). Screw three M12 bolts into the threaded holes in the front bearing retainer and, holding these bolts, remove the front bearing retainer and outer race.

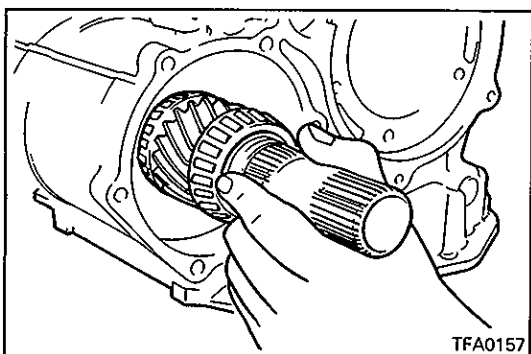

58. Remove the front output shaft.

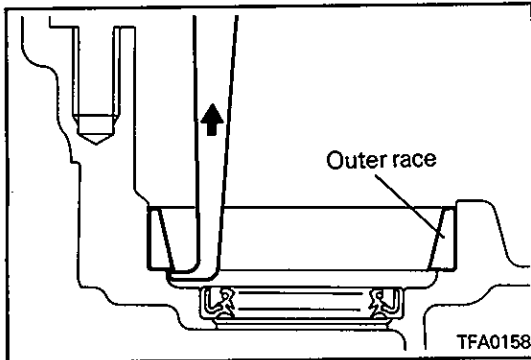

59. Using a sliding hammer or similar tool, remove the outer race.
60. Remove the oil seals.

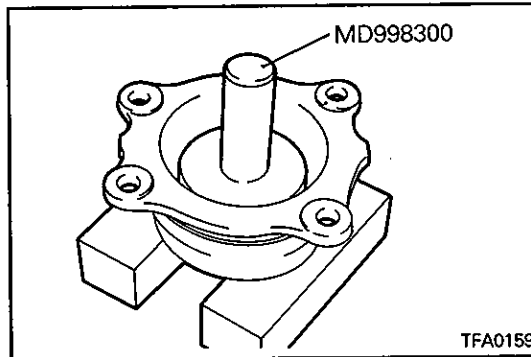

REASSEMBLY

1. Using the special tool, install the oil seals to the differential bearing retainer and the transmission case.

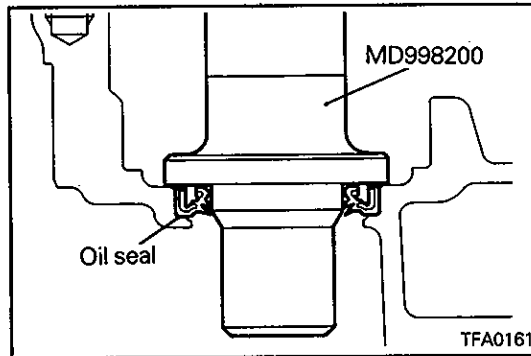
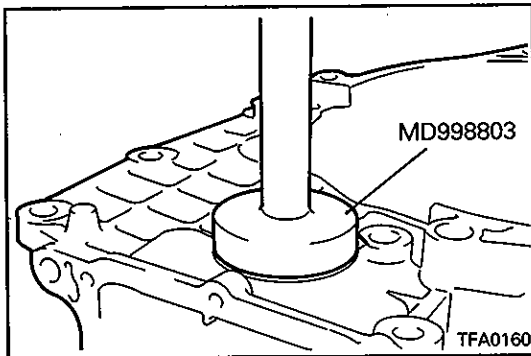

2. Using the special tool, install the rear output shaft oil seal.

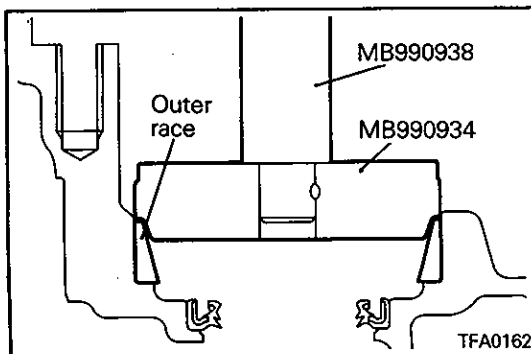

3. Using the special tool, press-fit the outer race in the transmission case.

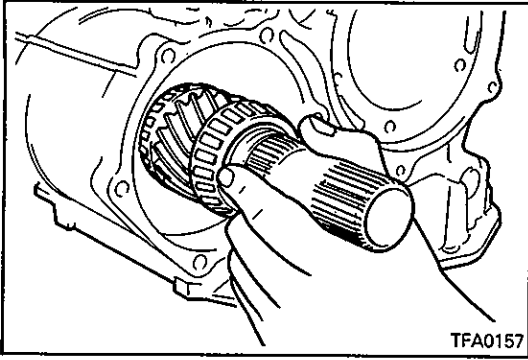

4. Install the front output shaft assembly.

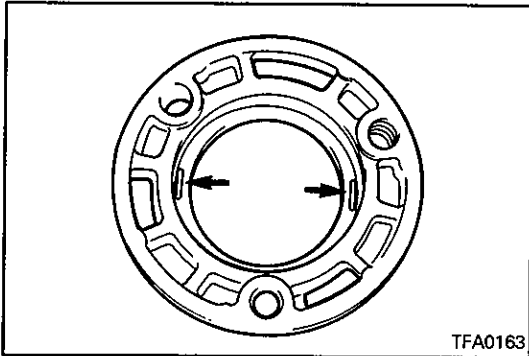

5. Place approx. 10 mm (40 in.) long, 1.6 mm (0.06 in.) diameter solder in the front bearing retainer at the positions shown in the figure and install the outer race.

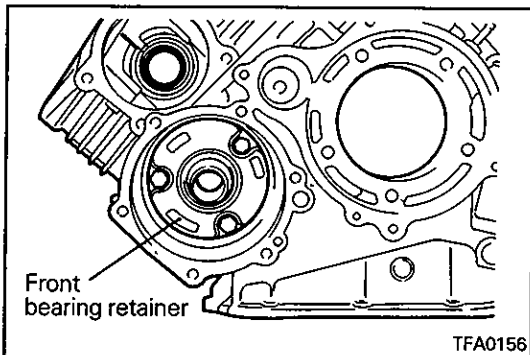

6. Install the front bearing retainer and tighten the bolts to the specified torque.

**Front bearing retainer mounting bolts:
49 Nm (4.9 kgm, 35 ft.lbs.)**

7. Loosen the bolts and remove the front bearing retainer.
8. Remove the outer race from the front bearing retainer and remove the solder. If the solder does not break, perform the work in steps 5 – 8 with a larger diameter solder. Measure the thickness of the crushed solder with a micrometer and select a spacer with the correct thickness that ensures the preload standard value.

**Standard value:
0.055 – 0.115 mm (0.0022 – 0.0045 in.)**

9. Install the selected spacer and the outer race in the front bearing retainer.
10. Install the front bearing retainer using the bolts coated with sealant. Tighten the bolts to the specified torque.

**Specified sealant:
3M STUD Locking No. 4170 or equivalent
Front bearing retainer mounting bolts:
49 Nm (4.9 kgm, 35 ft.lbs.)**

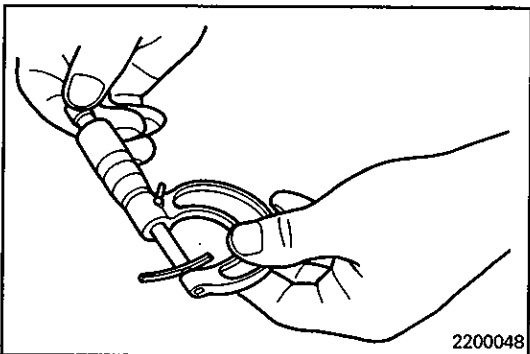

11. Using a bearing puller, support the viscous coupling and insert it in the case. Install the stopper ring.

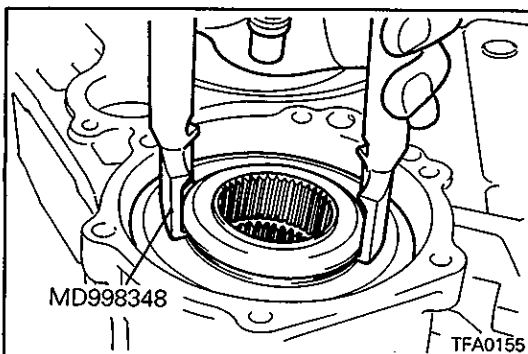

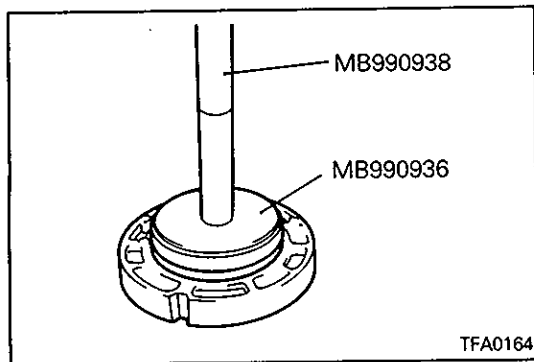

12. Using the special tool, install the outer race in the center bearing retainer.

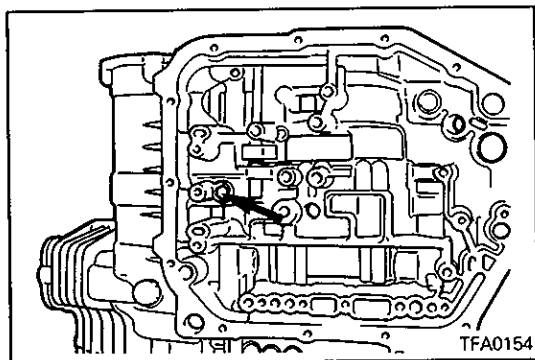

13. Install the center bearing retainer stopper bolt.

**Center bearing retainer stopper bolt:
5 Nm (0.5 kgm, 4 ft.lbs.)**

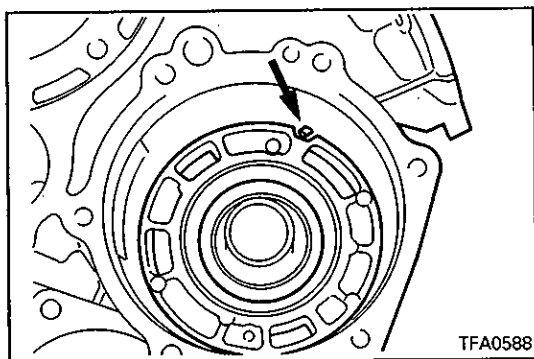

14. Install the center bearing retainer so that the stopper bolt fits in the groove of the center bearing retainer.

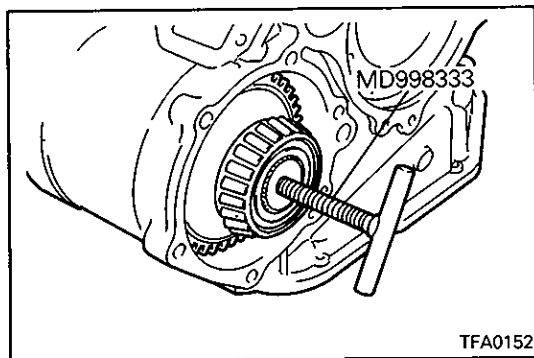

15. Install the special tool in the center differential and install the center differential in the transmission case.

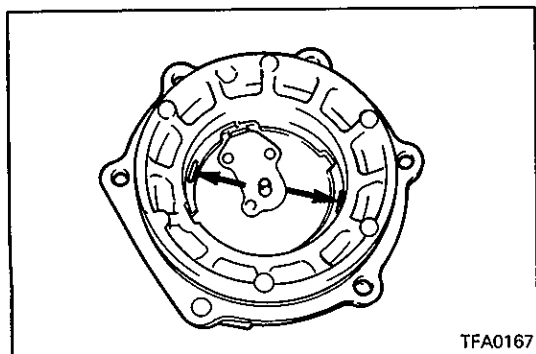

16. Place two pieces of approx. 10 mm (0.39 in.) long, 1.6 mm (0.06 in.) diameter solder on the output bearing retainer at the positions shown in the diagram and install the outer race.

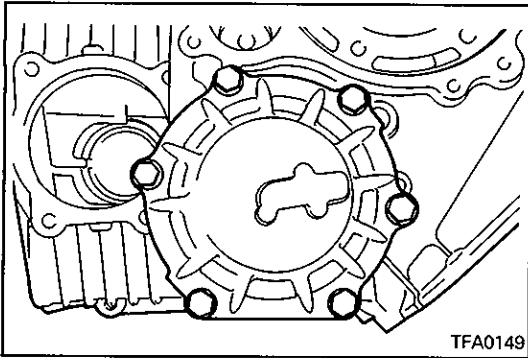

17. Install the output bearing retainer and tighten the bolts to the specified torque.

Output bearing retainer mounting bolts:
24 Nm (2.4 kgm, 18 ft.lbs.)

18. Loosen the bolts and remove the output bearing retainer.

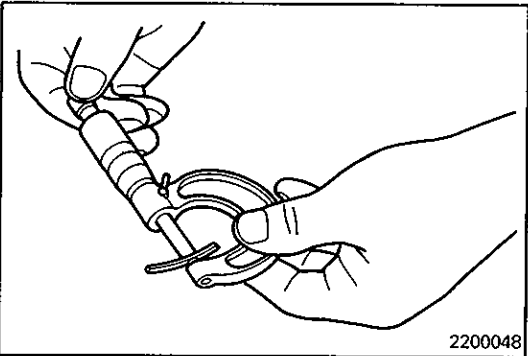

19. Remove the outer race from the output bearing retainer and remove the solder. If the solder is not crushed, repeat steps 16 – 18, using a 3 mm (0.12 in.) diameter solder. Measure the thickness of the crushed solder with a micrometer and select a spacer with a thickness that will provide the standard preload value.

Standard value:
0.075 – 0.135 mm (0.003 – 0.0053 in.)

20. Install the selected spacer and the outer race on the output bearing retainer.

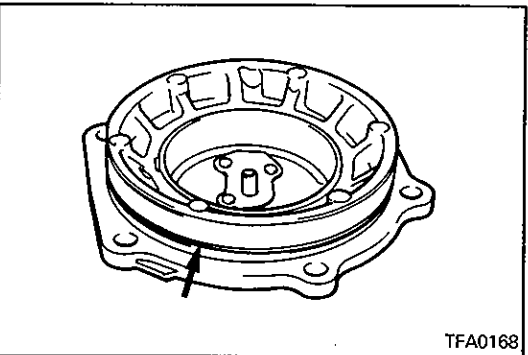

21. Install a new O-ring on the outer circumference of the outer bearing retainer.
 22. Coat the O-ring with automatic transmission fluid and tighten the output bearing retainer mounting bolts to the specified torque.

Output bearing retainer mounting bolts:
24 Nm (2.4 kgm, 18 ft.lbs.)

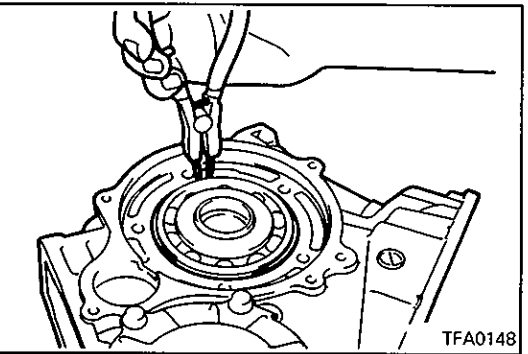

23. Insert the output flange into the case and install the snap ring around the bearing.

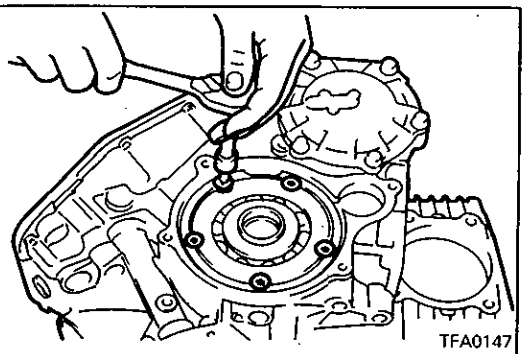

24. Install the bearing retainer using new bolts.

Bearing retainer mounting bolts:
20 Nm (2.0 kgm, 15 ft.lbs.)

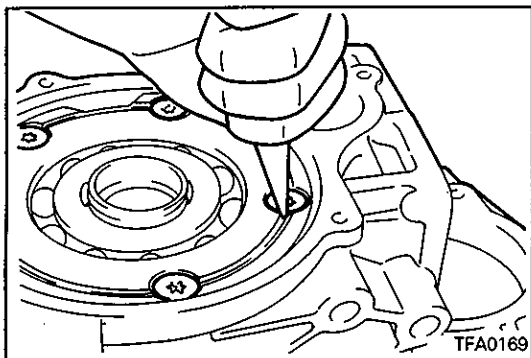

25. Caulk the head of each bolt.

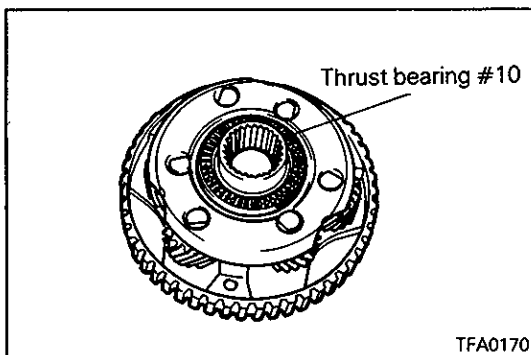

26. Apply a coating of petrolatum to thrust bearing #10 and attach the bearing to the planetary carrier.

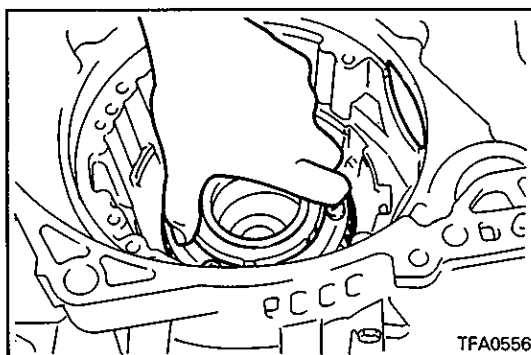

27. Install the planetary carrier in place.

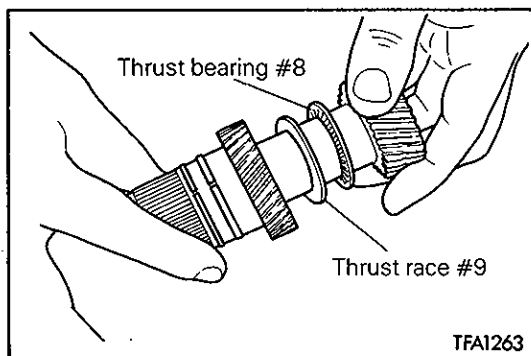

28. Assemble thrust race #9, thrust bearing #8 and the reverse sun gear on the forward sun gear.

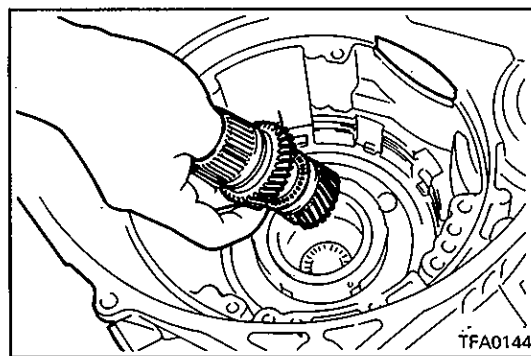

29. Install the forward and reverse sun gear assembly into the planetary carrier.

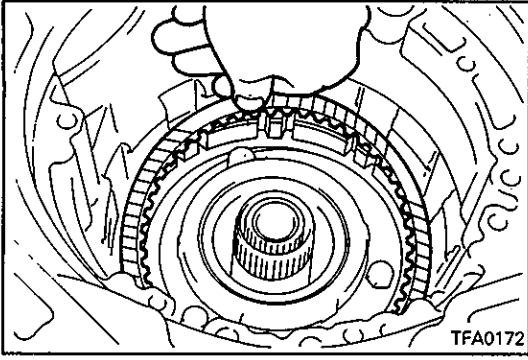

30. Assemble the reaction plate, the brake disc and the brake plate.

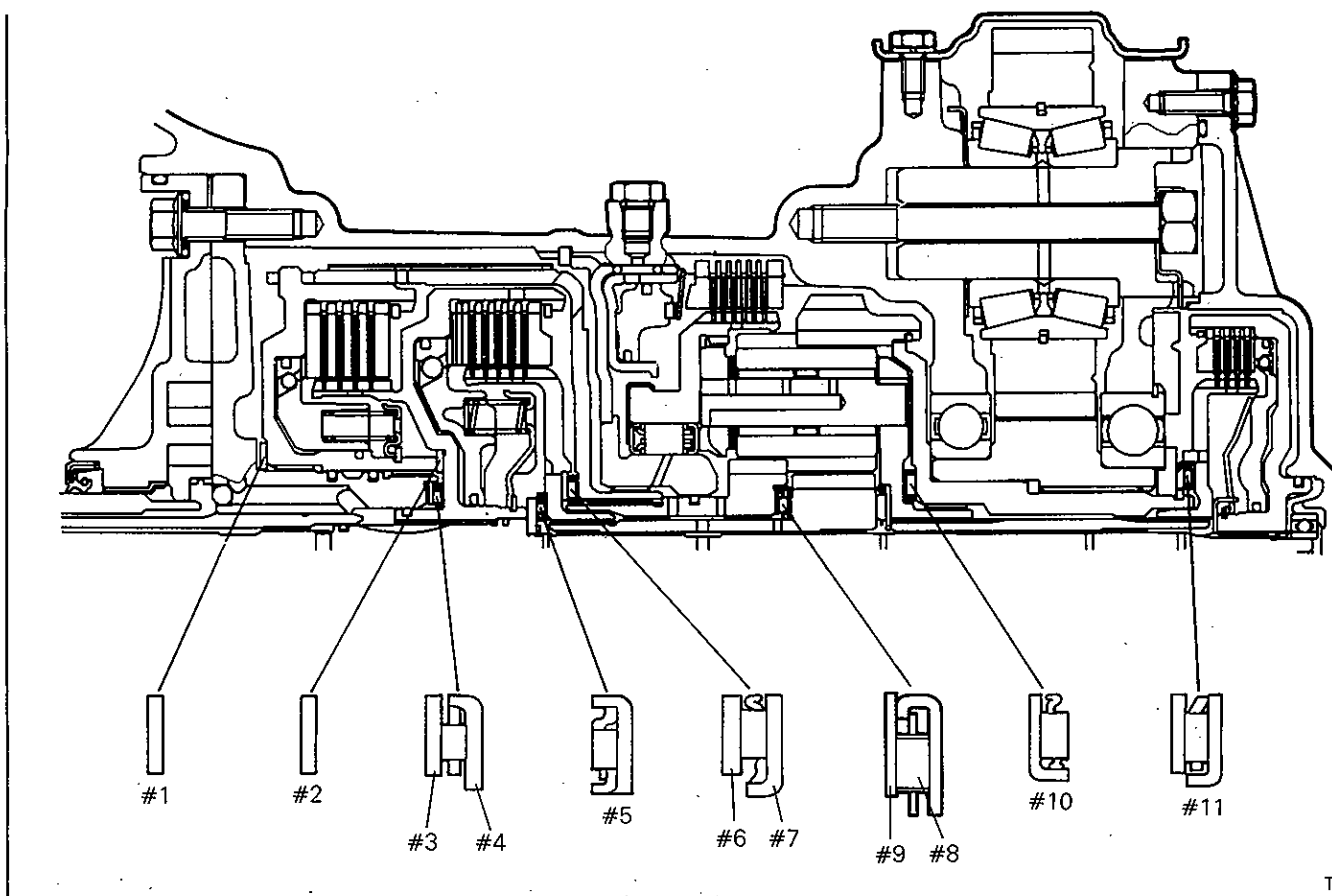

TFA1264

Identification of thrust bearings, thrust races and thrust washers

mm (in.)									
Outer diameter	Inner diameter	Thickness	Part No.	Code No.	Outer diameter	Inner diameter	Thickness	Part No.	Code No.
70 (2.7559)	55.7 (2.1929)	1.4 (.0551)	*1	#1	48.1 (1.8937)	34.4 (1.3543)	–	MD707271	#4
70 (2.7559)	55.7 (2.1929)	1.8 (.0709)	*2		42.6 (1.6772)	28 (1.1024)	–	MD720753	#5
70 (2.7559)	55.7 (2.1929)	2.2 (.0866)	*3		54 (2.1260)	38.7 (1.5236)	1.6 (.0630)	MD704936	#6
70 (2.7559)	55.7 (2.1929)	2.6 (.1024)	*4		52 (2.0472)	36.4 (1.4331)	–	MD720010	#7
70 (2.7559)	55.7 (2.1929)	1.8 (.0709)	MD729336 (W4A32) MD731212 (W4A33)	#2	41 (1.6142)	28 (1.1024)	1.2 (.0472)	MD728763 (W4A32)	#8
48.9 (1.9252)	37 (1.4567)	1.0 (.0394)	MD997854 (incl *1)	#3	45 (1.7717)	28 (1.1024)	–	MD735062 (W4A33)	
48.9 (1.9252)	37 (1.4567)	1.2 (.0472)	MD997847 (incl *1)		39 (1.5354)	28 (1.1024)	–	MD728764 (W4A32)	
48.9 (1.9252)	37 (1.4567)	1.4 (.0551)	MD997848 (incl *2)		46 (1.8110)	31 (1.2205)	0.8 (.0315)	MD735063 (W4A33)	#9
48.9 (1.9252)	37 (1.4567)	1.6 (.0630)	MD997849 (incl *2)		52 (2.0472)	36.4 (1.4331)	–	MD720010	#10
48.9 (1.9252)	37 (1.4567)	1.8 (.0709)	MD997850 (incl *3)		58 (2.2835)	44 (1.7323)	–	MD724206	#11
48.9 (1.9252)	37 (1.4567)	2.0 (.0787)	MD997851 (incl *3)						
48.9 (1.9252)	37 (1.4567)	2.2 (.0866)	MD997852 (incl *4)						
48.9 (1.9252)	37 (1.4567)	2.4 (.0945)	MD997853 (incl *4)						

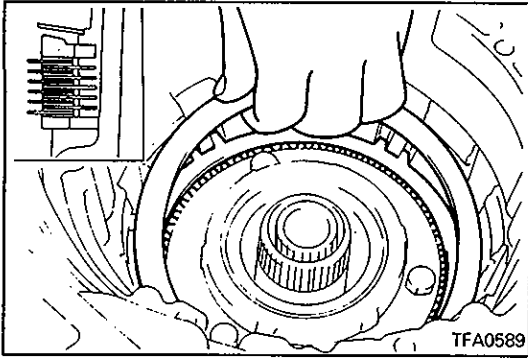

31. Install the originally installed pressure plate and install the return spring.

Caution

- Position the return spring correctly when installing.

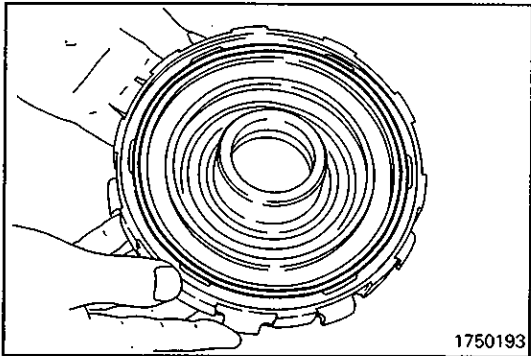

32. Apply a coating of petrolatum jelly to the wave spring and attach it to the center support.

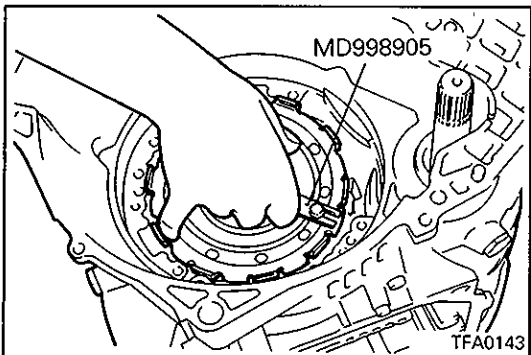

33. Mount the special tool on the center support, install 2 new O-rings on the support and push it into the transmission case.

Caution

1. Coat the O-rings with automatic transmission fluid and align the oil holes.
2. Do not move the wave spring out of position when installing.

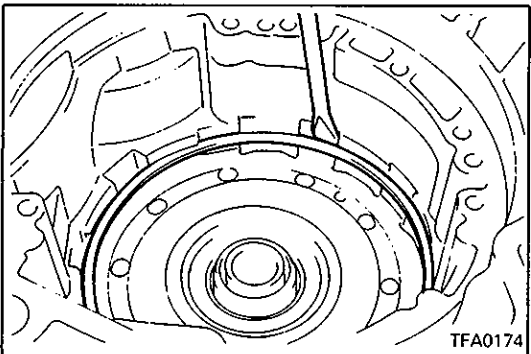

34. Install the snap ring.

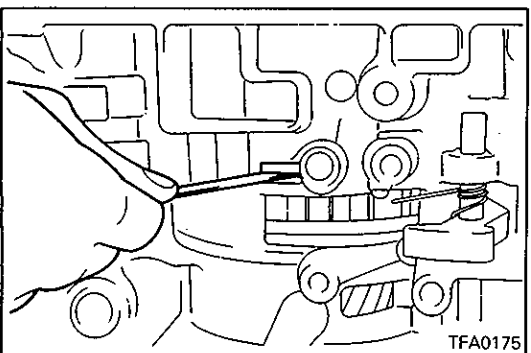

35. Use a thickness gauge and measure the end play of the low/reverse brake. If necessary, adjust to the standard value by selecting a pressure plate of proper thickness.

Standard value: 1.0 – 1.2 mm (0.039 – 0.047 in.)

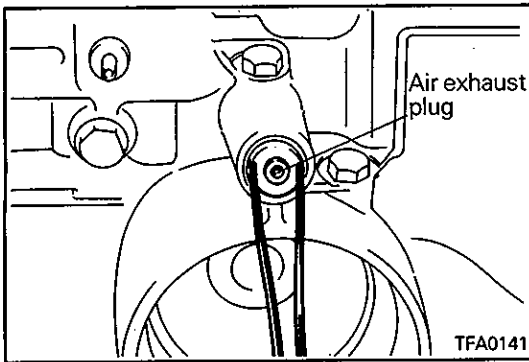

36. Install the air exhaust plug, and then install the plug.
Air exhaust plug: 33 Nm (3.3 kgm, 24 ft.lbs.)

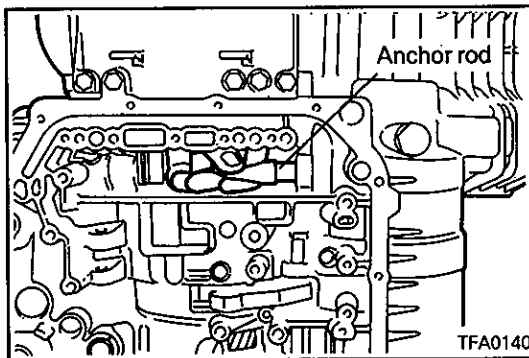

37. Install the anchor rod.

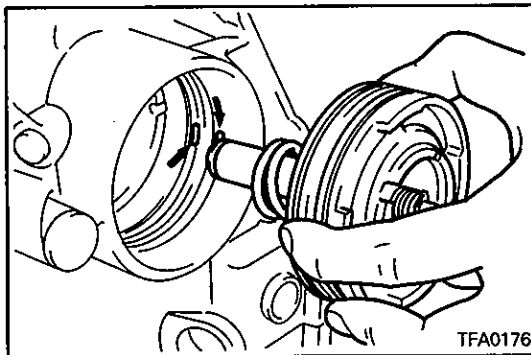

38. Install the kickdown servo spring, piston and sleeve.

Caution

- The seal ring alignment hole in the kickdown servo piston must not overlap the oil filler ports (indicated by the arrows in the diagram).

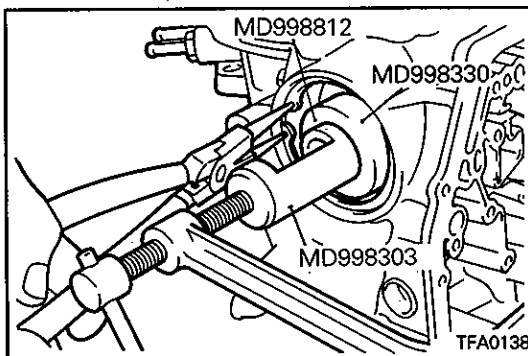

39. Use the special tool to hold the kickdown servo piston and sleeve pressed, and install the snap ring.

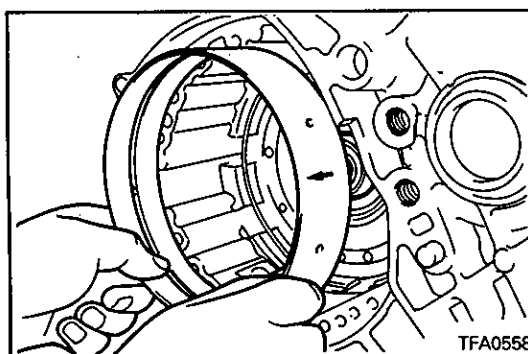

40. Install the kickdown band.

Caution

- Install with the arrow mark pointing to the front.

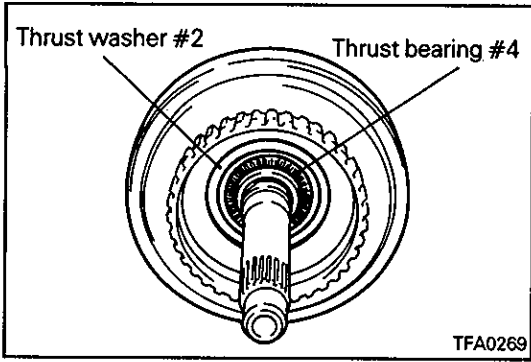

41. Install thrust bearing #4 and thrust washer #2 on the rear clutch.

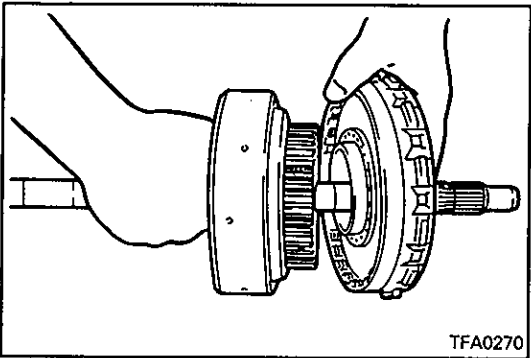

42. Combine the rear clutch assembly and the front clutch assembly.

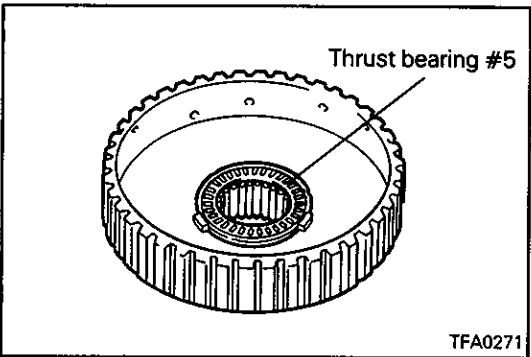

43. Install thrust bearing #5 on the rear clutch hub.

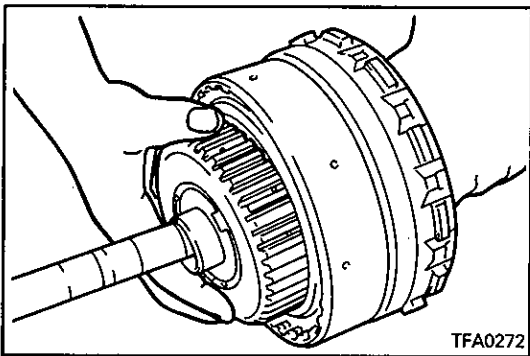

44. Install the rear clutch hub on the rear clutch.

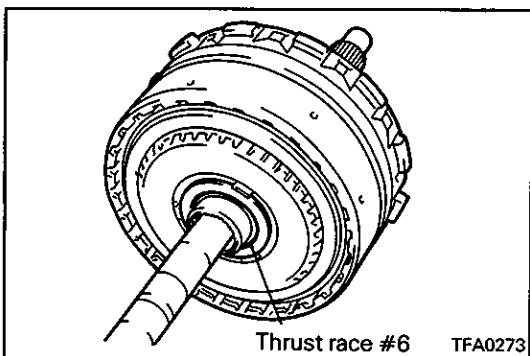

45. Install thrust race #6 on the end of the rear clutch hub.

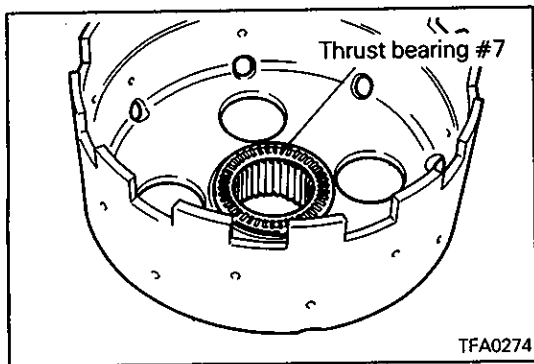

46. Install thrust bearing #7 in the kickdown drum.

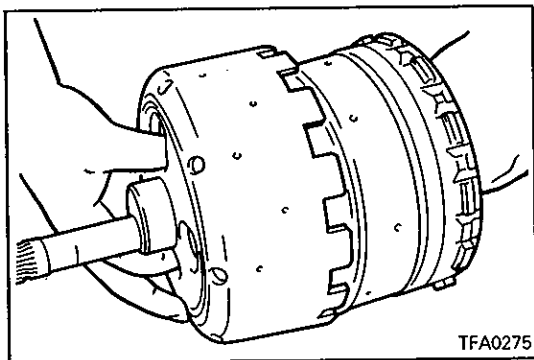

47. Assemble the clutch assembly in the kickdown drum.

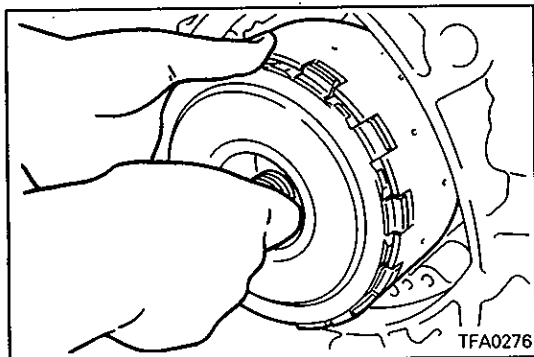

48. Install the assembled clutch assembly and kickdown drum into the transaxle case.

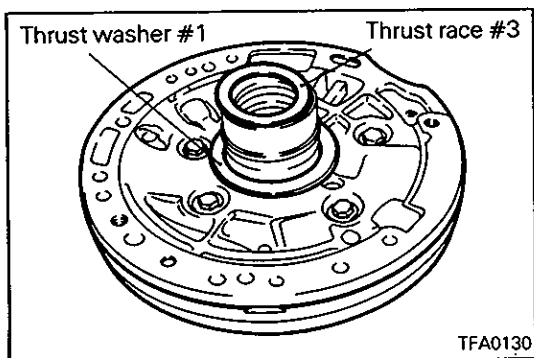

49. Install thrust race #3 and thrust washer #1 on the back of the oil pump using petrolatum jelly to hold them in place.

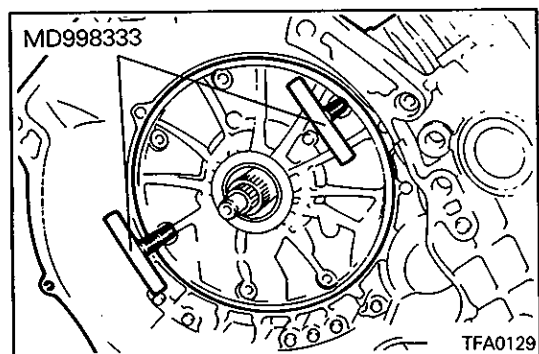

50. Use the special tool to install the oil pump assembly with a new gasket.

**Oil pump assembly mounting bolts:
21 Nm (2.1 kgm, 16 ft.lbs.)**

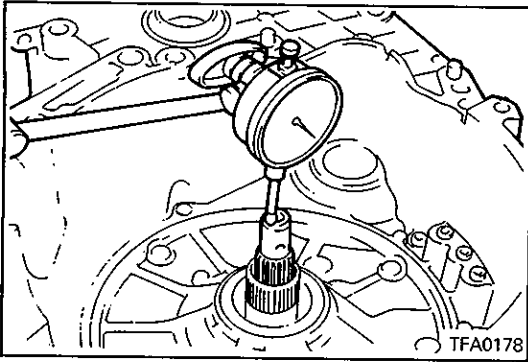

51. Measure the end play of the input shaft. If necessary, replace thrust race #3 and thrust washer #1 with ones of proper thickness to adjust to the standard value.

Standard value: 0.3 – 1.0 mm (0.012 – 0.039 in.)

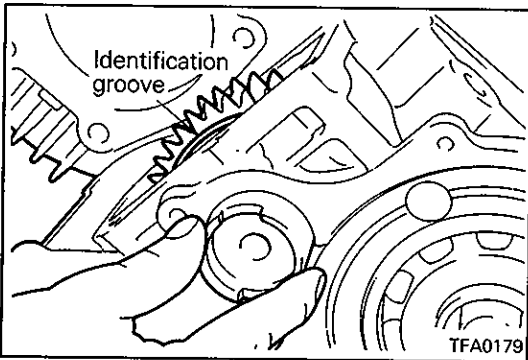

52. Install the spacer, the idler gear and the bearing and then insert the idler shaft. Assemble with the identification groove on the idler gear facing the rear.

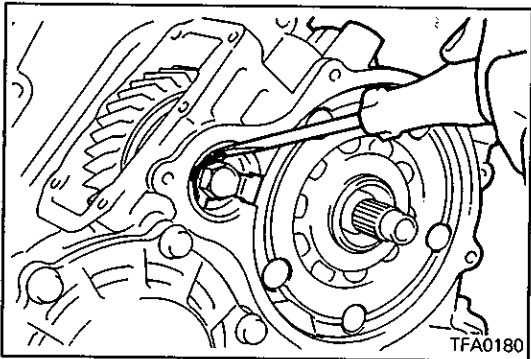

53. Tighten the idler shaft lock bolt to the specified torque with a new lock plate placed under the bolt head. Bend the 3 lugs of the lock plate to prevent the bolt from turning.

Idler shaft lock bolt: 38 Nm (3.8 kgm, 28 ft.lbs.)

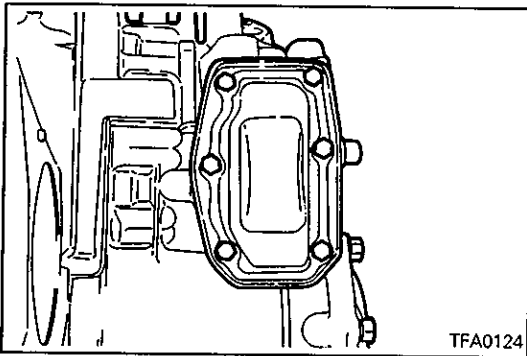

54. Install the idler gear cover with a new gasket.

**Idler gear cover mounting bolts:
11 Nm (1.1 kgm, 8 ft.lbs.)**

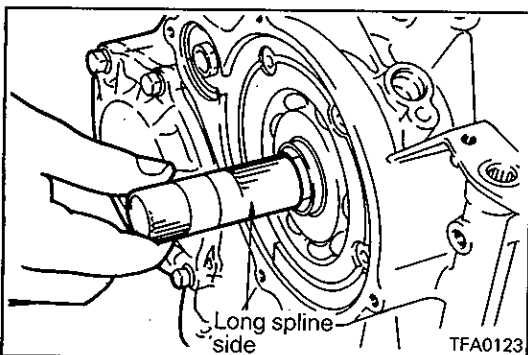

55. Install the end clutch shaft, first inserting the end with longer splines.

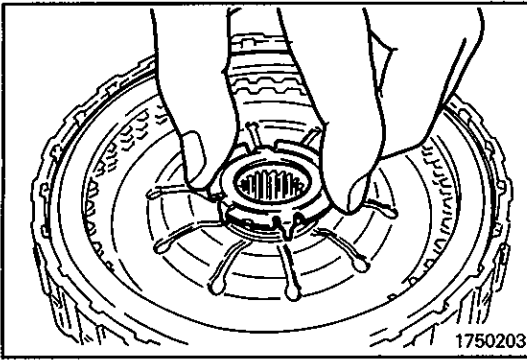

56. Fit the thrust washer on the return spring of the end clutch.

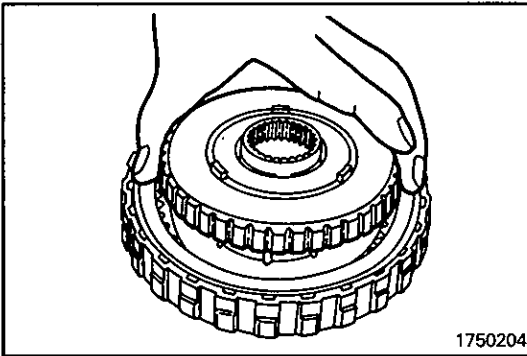

57. Install the end clutch hub on the end clutch assembly.

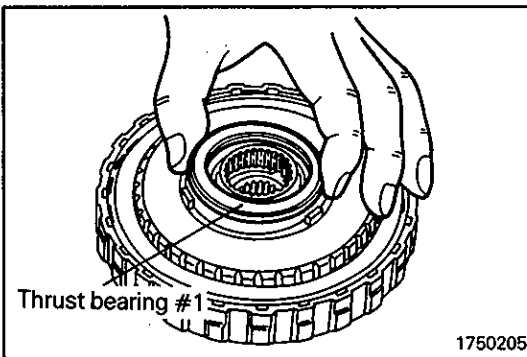

58. Install thrust bearing #1 to the end of the clutch hub using petrolatum jelly to hold it in place.

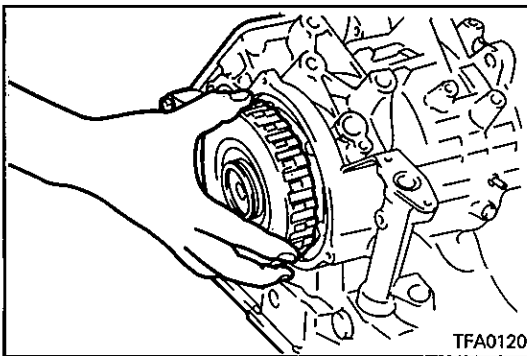

59. Install the end clutch assembly.

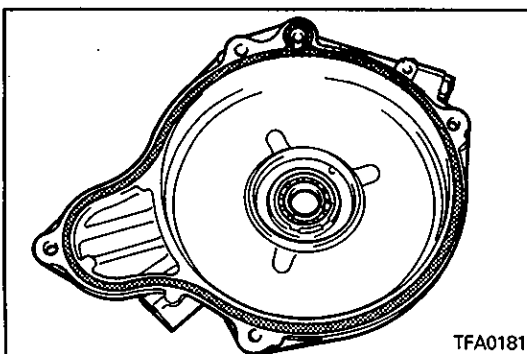

60. Attach a new O-ring to the end clutch cover.

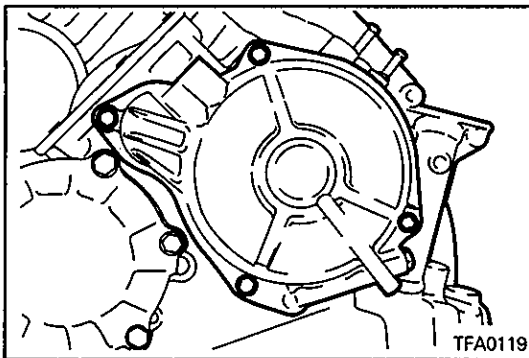

61. Install the end clutch cover and tighten the bolts to the specified torque.

**End clutch cover mounting bolts:
11 Nm (1.1 kgm, 8 ft.lbs.)**

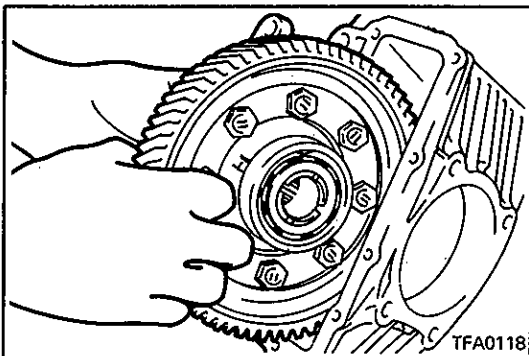

62. Install the differential assembly.

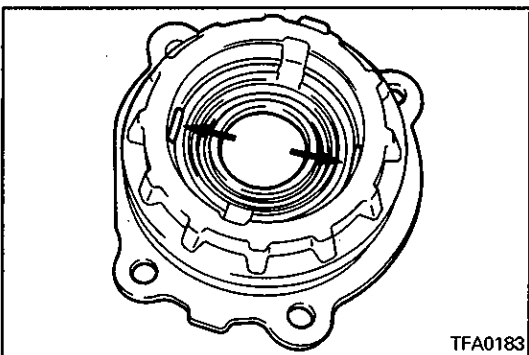

63. Place two pieces of approx. 10 mm (0.39 in.) long, 1.6 mm (0.06 in.) diameter solder on the differential rear bearing retainer at the positions shown in the diagram and install the outer race.

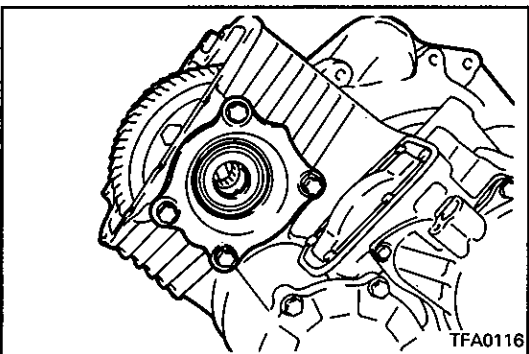

64. Install the differential rear bearing retainer and tighten the bolts to the specified torque.

65. Loosen the bolts, remove the differential rear bearing retainer and remove the solder. If the solder is not crushed, repeat steps 63 – 64, using a 3 mm diameter solder.

**Differential rear bearing retainer mounting bolts:
35 Nm (3.5 kgm, 26 ft.lbs.)**

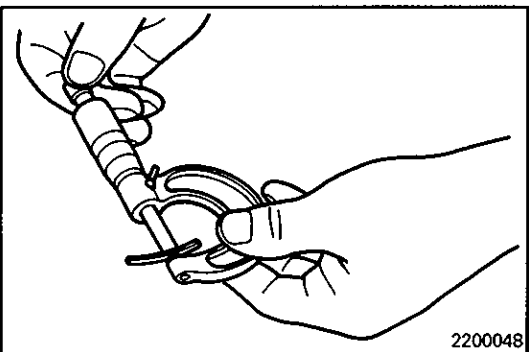

66. Measure the thickness of the crushed solder with a micrometer and adjust by selecting a spacer of the thickness that will ensure the standard end play and preload value.

**Standard value:
0.075 – 0.135 mm (0.003 – 0.0053 in.)**

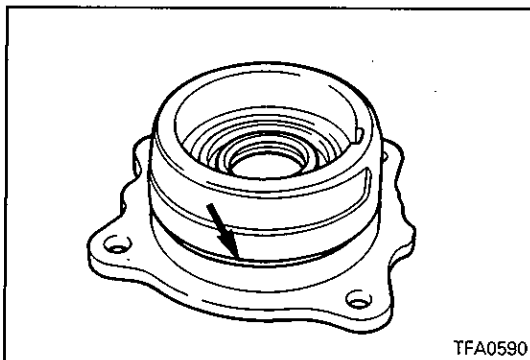

67. Install a new O-ring on the differential rear bearing retainer, coat the O-ring with automatic transmission fluid; then install the retainer in the transaxle case and tighten the mounting bolts to the specified torque.

Differential rear bearing retainer mounting bolts:
35 Nm (3.5 kgm, 26 ft.lbs.)

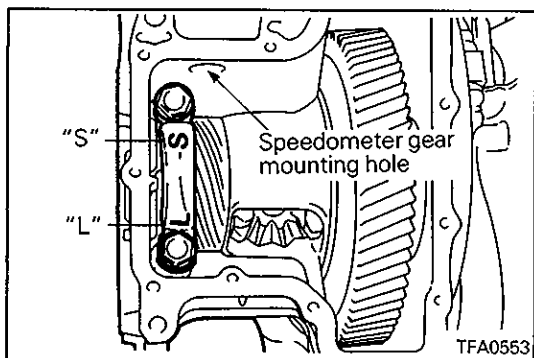

68. Install the front bearing cap and tighten the bolts to the specified torque. Use the shorter bolt on the "S" marked side and the longer one on the "L" marked side of the cap.

Differential front bearing cap mounting bolts:
70 Nm (7.0 kgm, 51 ft.lbs.)

69. Install the differential cover with a new gasket.

Differential cover mounting bolts:
11 Nm (1.1 kgm, 8 ft.lbs.)

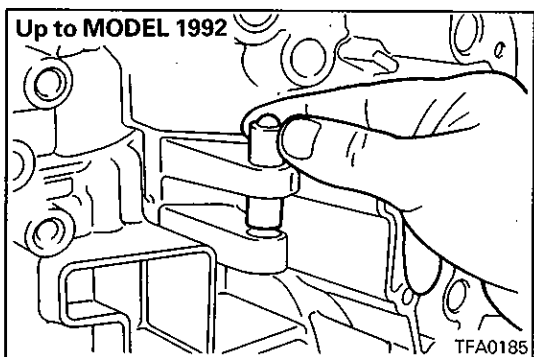

70. Install the detent assembly. <Up to MODEL 1992> or detent plate <MODEL 1993>

Detent spring mounting bolt <MODEL 1993>:
11 Nm (1.1 kgm, 8 ft.lbs.)

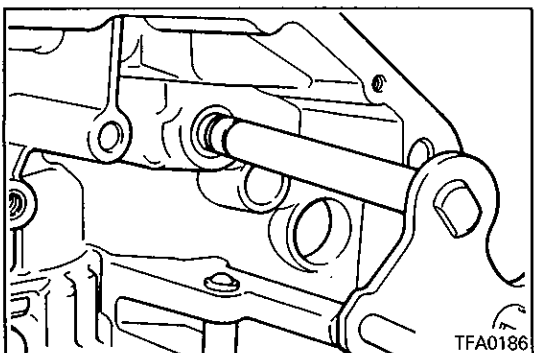
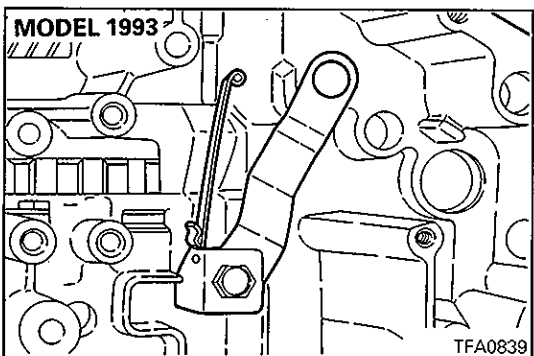

71. Install a new O-ring on the manual control shaft assembly, coat the O-ring with automatic transmission fluid and then insert the shaft assembly into the transmission case.
72. Align the groove in the manual control shaft and the set screw hole; then install the set screw.

Manual control shaft set screw:
9 Nm (0.9 kgm, 7 ft.lbs.)

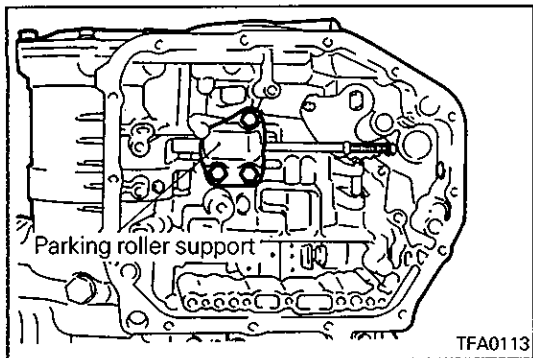

73. Install the parking roller support.

**Parking roller support mounting bolts:
24 Nm (2.4 kgm, 18 ft.lbs.)**

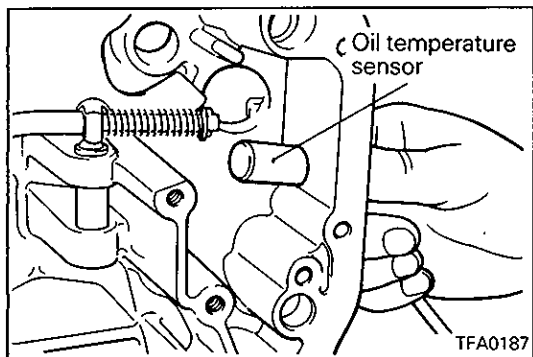

74. Insert the oil temperature sensor into the case.

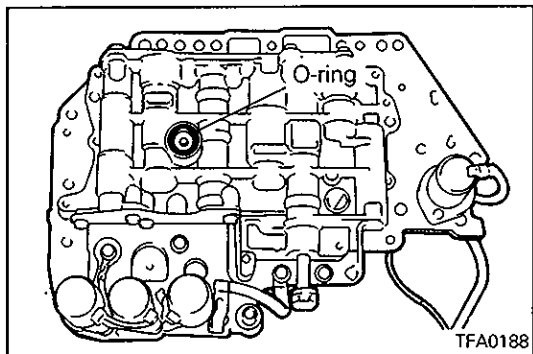

75. Install the O-ring in the O-ring groove at the top of the valve body assembly.

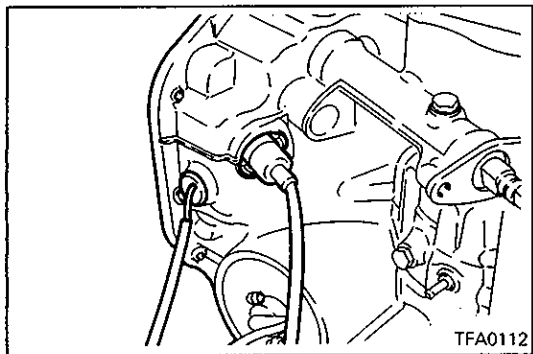

76. Replace the solenoid valve harness grommet O-ring with a new one.

77. Pass the solenoid valve connector through the hole in the transmission case from inside the case.

78. Push the solenoid valve harness grommet into the case hole.

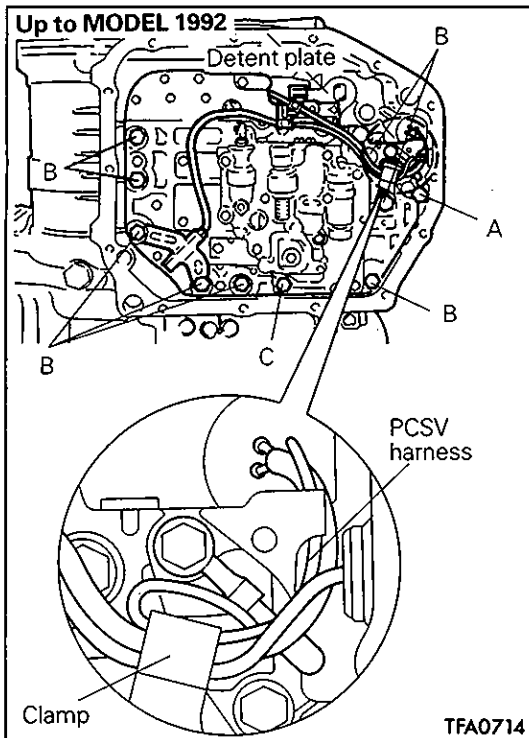

79. Insert the knock pin of the valve body into the case, keeping the detent plate pin in the manual valve groove. Temporarily install the valve body, install the oil temperature sensor and holder; then tighten the mounting bolts to the specified torque.

A bolt: 18 mm (0.709 in.)

B bolt: 25 mm (0.984 in.)

C bolt: 40 mm (1.575 in.)

Valve body assembly mounting bolts:
11 Nm (1.1 kgm, 8 ft.lbs.)

Caution

- Firmly fasten the solenoid valve and the oil temperature sensor harness at the position shown in the illustration.

Especially, the pressure control solenoid valve (PCSV) harness, which is separated from other harness should be routed and clamped as shown in the illustration. Failure to fasten it may result in contact with the detent plate or parking rod.

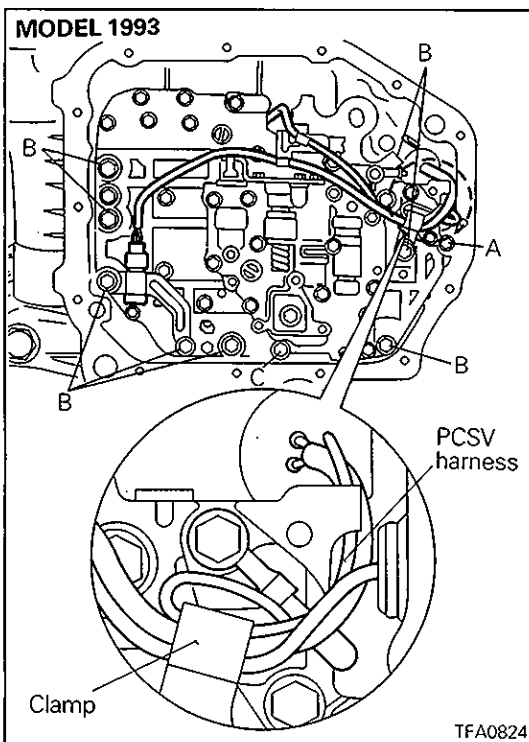

80. Install the oil screen.

Oil filter mounting bolts: 6 Nm (0.6 kgm, 5 ft.lbs.)

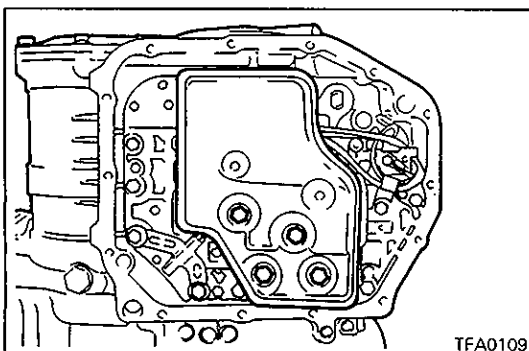

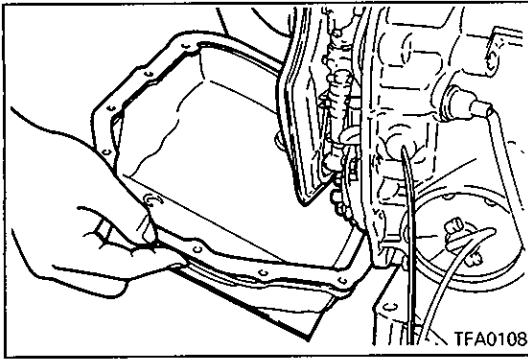

81. Install the magnets in the oil pan and install the oil pan.
Oil pan mounting bolts: 11 Nm (1.1 kgm, 8 ft.lbs.)

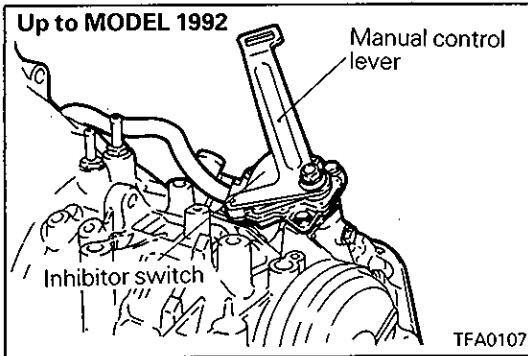

82. Install the inhibitor switch and the manual control lever.
Inhibitor switch mounting bolts: 11 Nm (1.1 kgm, 8 ft.lbs.)
Manual control lever mounting bolt: 19 Nm (1.9 kgm, 14 ft.lbs.)

83. Install the speedometer gear assembly.

Speedometer gear locking plate mounting bolt: 5 Nm (0.5 kgm, 4 ft.lbs.)

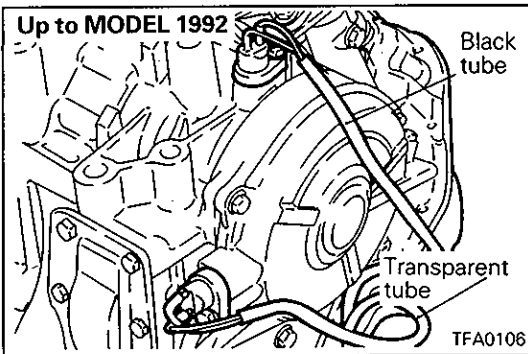
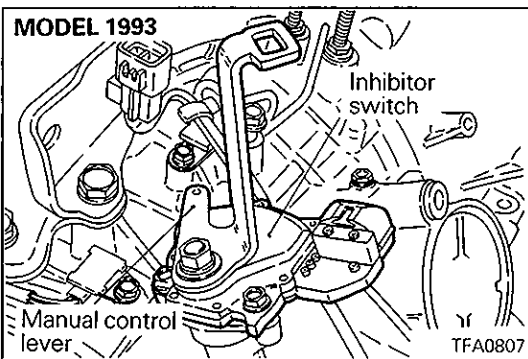

84. Install pulse generators A and B.

Pulse generator mounting bolts: 11 Nm (1.1 kgm, 8 ft.lbs.)

Caution

- **Install the black tube on the output gear side and the transparent tube on the end clutch side.**

85. Install the oil filler tube and insert the level gauge.

Oil filler tube mounting bolt: 24 Nm (2.4 kgm, 18 ft.lbs.)

86. Install the brackets.

Transmission mounting bracket bolts: 70 Nm (7.0 kgm, 51 ft.lbs.)

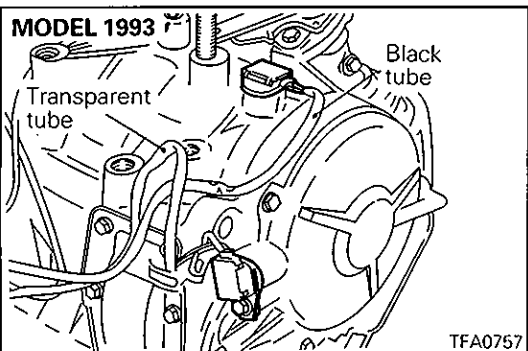

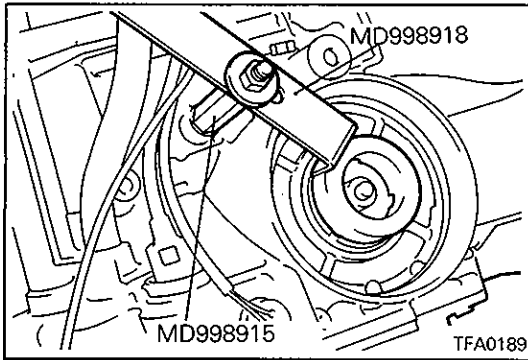

87. Adjust the kickdown servo by the following procedure:
- Fit the claw of the special tool in the notch of the piston to prevent the piston from turning, and use adapter to secure it as illustrated.

Caution

- Do not push the piston inward with the special tool.
- When the adapter is installed on the transmission case, do not apply excessive torque but only hand tighten it.

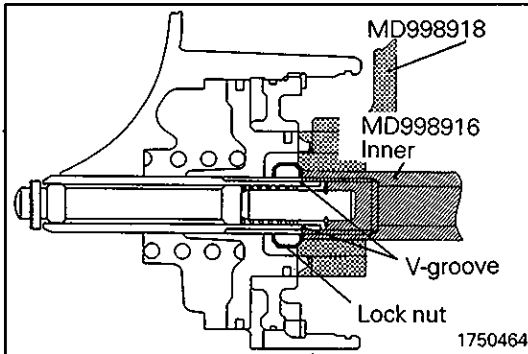

- Loosen the lock nut until it is about to reach the V groove in the adjusting rod. Install the special tool (inner) on the adjusting rod and turn down until it touches the lock nut.

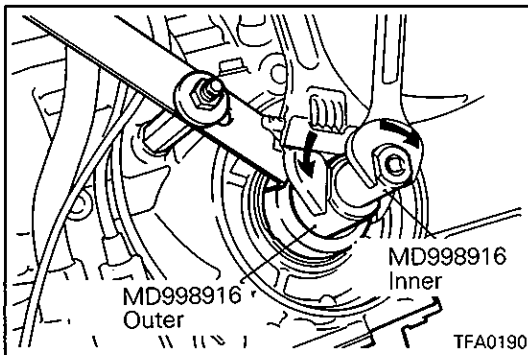

- Fit the special tool (outer) on the lock nut. Turn the outer tool counterclockwise and the inner tool clockwise to lock the lock nut against the inner tool.

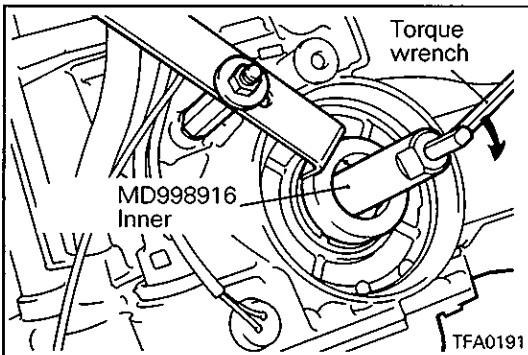

- Fit torque wrench to the inner tool to tighten it to a torque of 10 Nm (1.0 kgm, 7.2 ft.lbs.) and loosen. Repeat this sequence two times before finally tightening the inner tool to 5 Nm (0.5 kgm, 3.6 ft.lbs.) torque. Then back off the outer tool 2 to 2¼ turns.

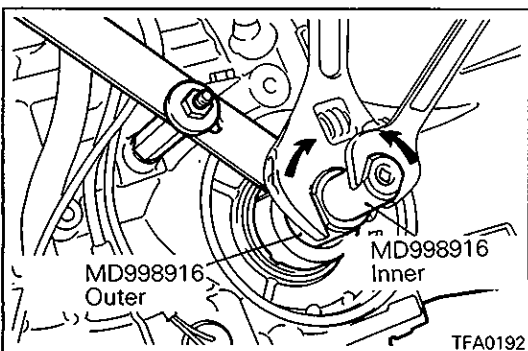

- Turn the outer tool clockwise and the inner tool counterclockwise to separate the lock nut from the inner tool.

Caution

- When doing this work, apply equal force to both tools.

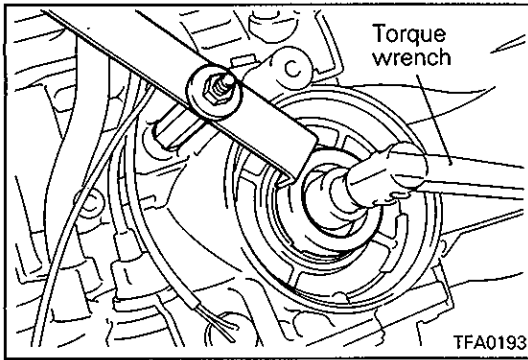

- (f) Hand tighten the lock nut until it touches the piston. Then, use torque wrench to tighten the lock nut to the specified torque.

Lock nut: 29 Nm (2.9 kgm, 21 ft.lbs.)

Caution

The lock nut may turn with the adjusting rod if tightened too quickly.

- (g) Remove the special tool that secures the piston. Install the plug to the Low/Reverse pressure outlet and tighten it to the specified torque.

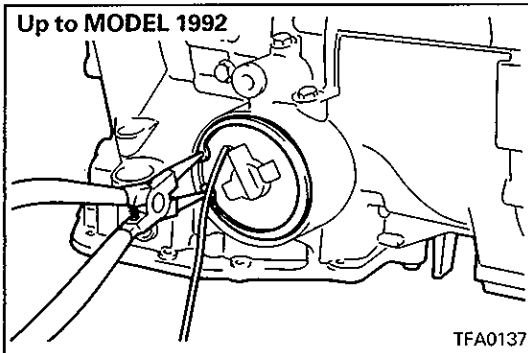

88. Install the kickdown servo switch and secure with the snap ring.

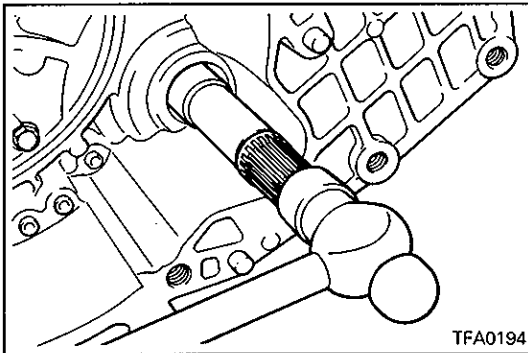
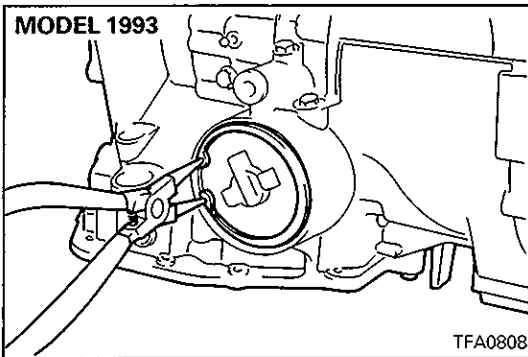

89. Insert the center shaft and hit it with a plastic hammer or similar tool to install it securely.

NOTE

Apply ATF to the oil seal lip and do not scratch it.

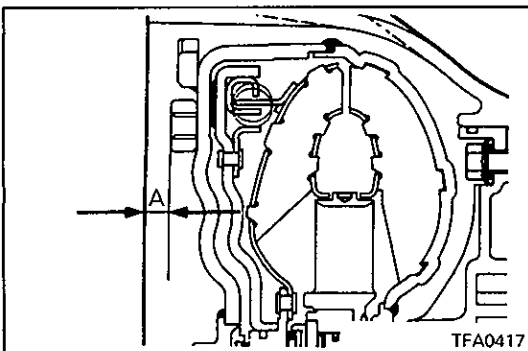

90. Coat the oil pump drive hub with automatic transmission fluid and install the torque converter. Push in firmly so that dimension A in the diagram is the standard value.

Standard value:

W4A33	approx. 16.3 mm (0.642 in.)
W4A32	approx. 12.4 mm (0.488 in.)

5. OIL PUMP

DISASSEMBLY AND REASSEMBLY

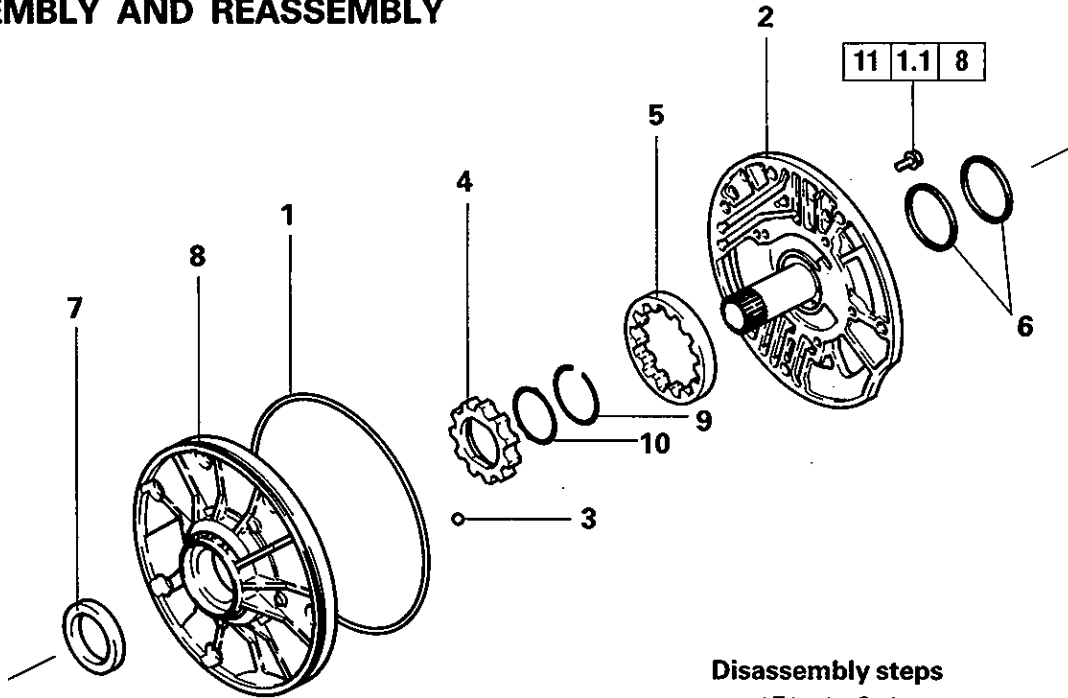

Disassembly steps

- ▶E▶ 1. O-ring
- ▶D▶ 2. Reaction shaft support
- ▶C▶ 3. Steel ball
- ◊A◊ ▶B▶ 4. Drive gear
- ◊A◊ ▶B▶ 5. Driven gear
- 6. Seal ring
- ▶A▶ 7. Oil seal
- 8. Oil pump housing
- 9. Snap ring
- 10. Oil seal

TFA0245

SERVICE POINTS OF DISASSEMBLY

◊A◊ REMOVAL OF DRIVE GEAR / DRIVEN GEAR

- (1) Make alignment marks on the drive and driven gears for correct reassembly.

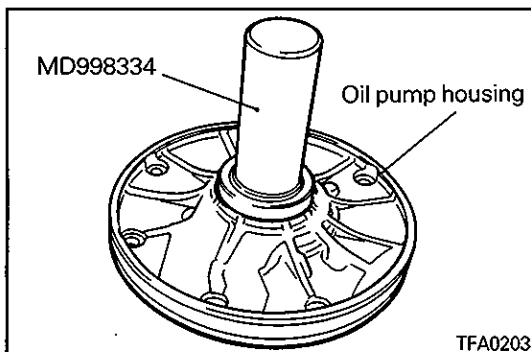

SERVICE POINTS OF REASSEMBLY

▶A▶ INSTALLATION OF OIL SEAL

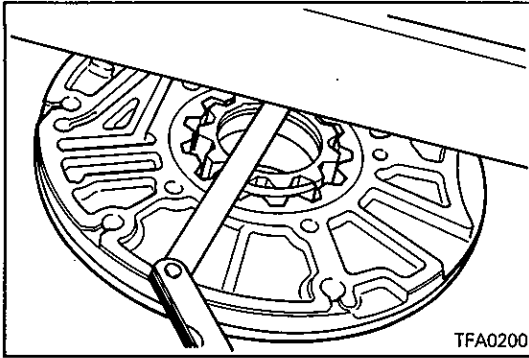

▶B◀ MEASUREMENT OF SIDE CLEARANCE OF DRIVEN GEAR / DRIVE GEAR

Standard value:
0.03 – 0.05 mm (0.001 – 0.002 in.)

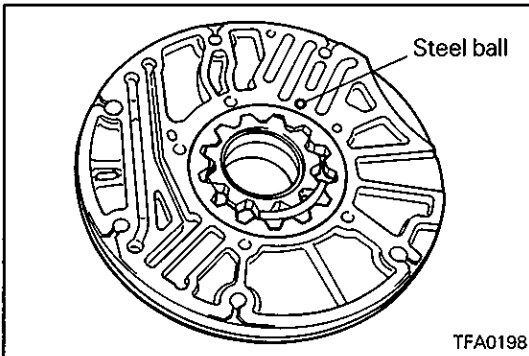

▶C◀ LOCATION OF STEEL BALL

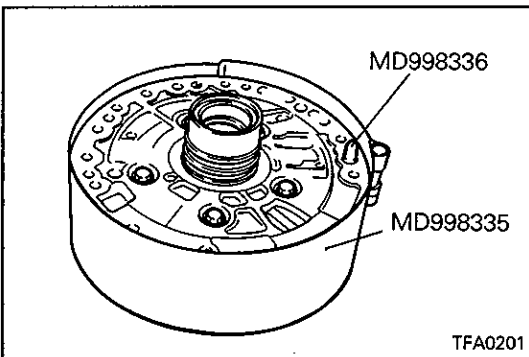

▶D◀ INSTALLATION OF REACTION SHAFT SUPPORT

- (1) Assemble the reaction shaft support and the pump housing, and tighten the five bolts by fingers.
- (2) Insert the special tool, Guide Pin MD998336, in the oil pump bolt hole and hold the support and the housing together with the special tool, Band MD998335, to align them.
- (3) Tighten the five bolts to the specified torque.
- (4) Make sure that the oil pump gear turns freely.

▶E◀ INSTALLATION OF O-RING

- (1) Install a new O-ring in the groove of the pump housing and apply petrolatum jelly to the O-ring.

6. FRONT CLUTCH
DISASSEMBLY AND REASSEMBLY

W4A32

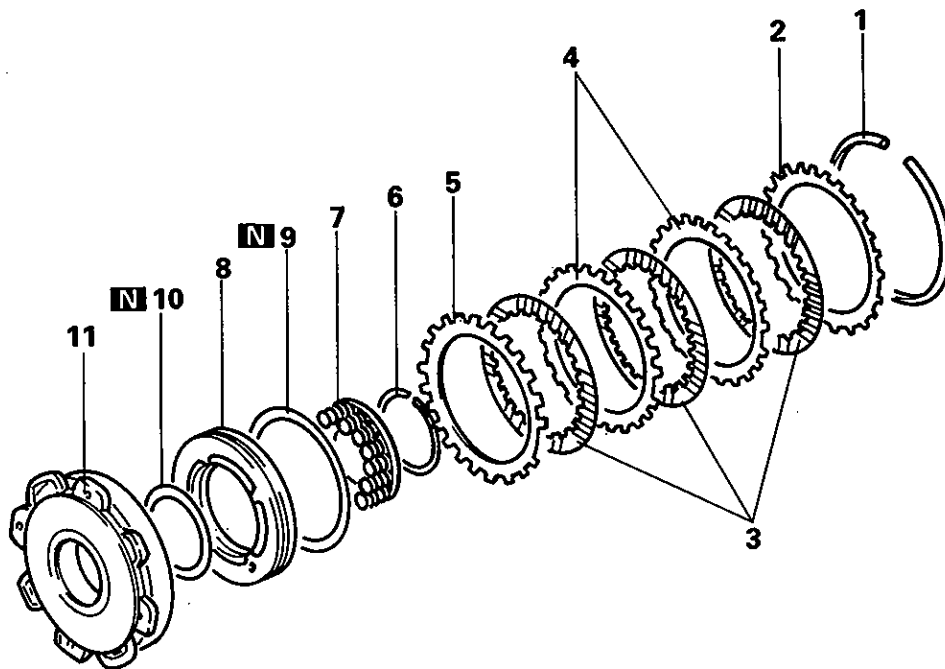

TFA0029

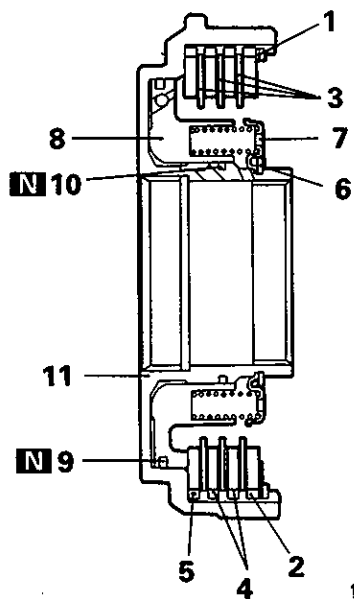

1750213

Disassembly steps

- ⇄C⇄ 1. Snap ring
- ⇄B⇄ 2. Clutch reaction plate
- 3. Clutch disc
- ⇄B⇄ 4. Clutch plate
- ⇄B⇄ 5. Clutch pressure plate
- ⇄A⇄ ⇄A⇄ 6. Snap ring
- 7. Return spring
- 8. Front clutch piston
- 9. D-ring
- 10. D-ring
- 11. Front clutch retainer

1750213

F4A33, W4A33

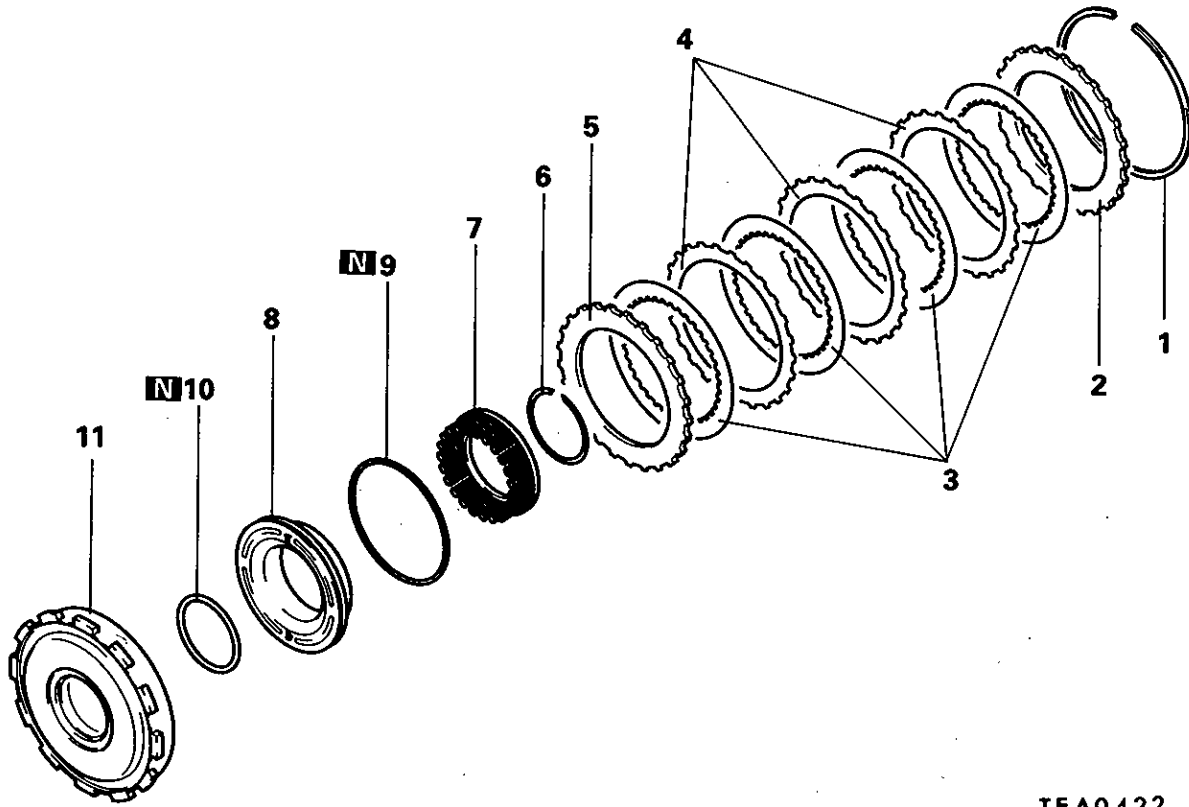

TFA0422

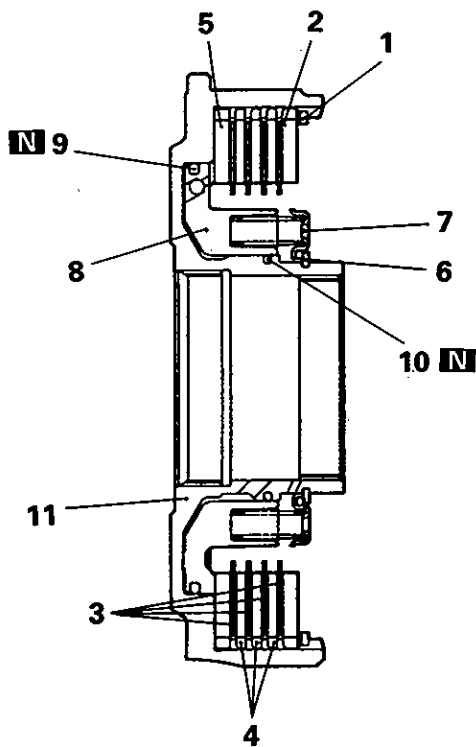

Disassembly steps

- ◆C◆ 1. Snap ring
- ◆B◆ 2. Clutch reaction plate
- 3. Clutch disc
- ◆B◆ 4. Clutch plate
- ◆B◆ 5. Clutch pressure plate
- ◁A▷ ◆A◆ 6. Snap ring
- 7. Return spring
- 8. Front clutch piston
- 9. D-ring
- 10. D-ring
- 11. Front clutch retainer

TFA0423

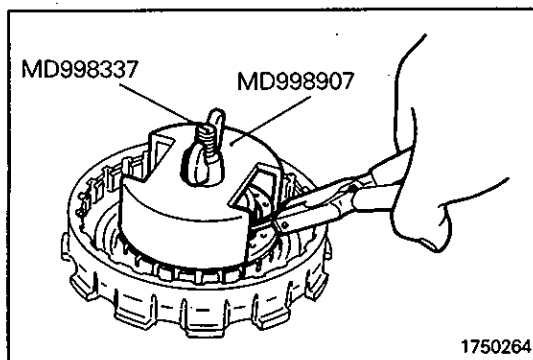

SERVICE POINT OF DISASSEMBLY

◁A▷ REMOVAL OF SNAP RING

- (1) Compress the return spring with the special tool.
- (2) Remove the snap ring.

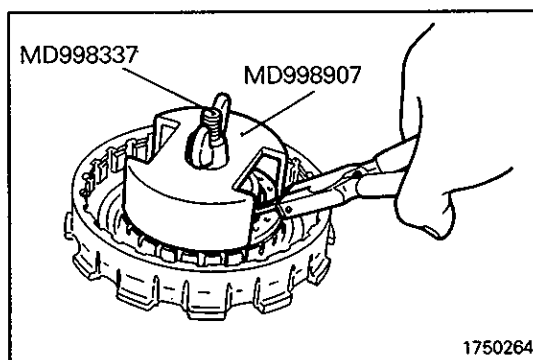

SERVICE POINTS OF REASSEMBLY

▷A◁ INSTALLATION OF SNAP RING

- (1) Compress the return spring with the special tool.
- (2) Install the snap ring.

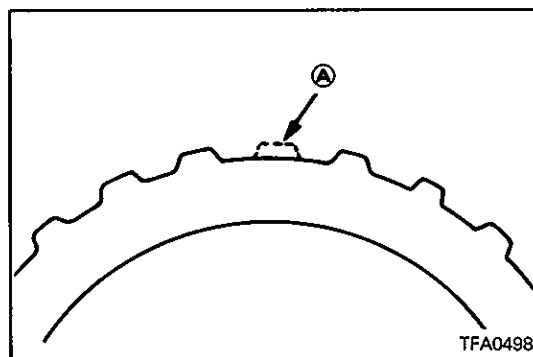

▷B◁ INSTALLATION OF CLUTCH PRESSURE PLATE / CLUTCH PLATE / CLUTCH REACTION PLATE

- (1) Install the clutch plate with their missing tooth portions (A in the illustration) in alignment.

NOTE

This design allows free flow of automatic transmission fluid thus improving the cooling efficiency of the plates and discs.

- (2) Install the innermost plate with their shear droops directed as shown in the illustration.

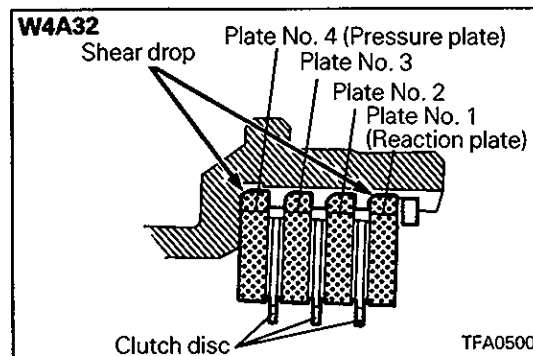

W4A32

Plate No.	Thickness mm (in.)	Identification mark
1	5.0 (0.197)	A
2	3.1 (0.122)	B
3	3.1 (0.122)	B
4	3.7 (0.146)	None

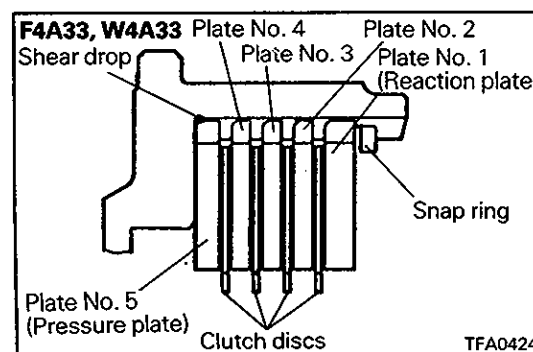

F4A33, W4A33

Plate No.	Thickness mm (in.)
1	5.0 (0.197)
2	2.2 (0.087)
3	2.2 (0.087)
4	2.2 (0.087)
5	3.8 (0.150)

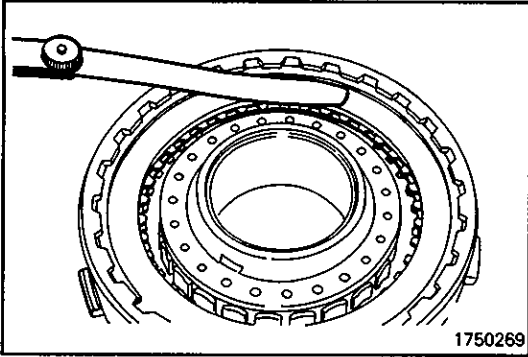
**⇄ SELECTION OF SNAP RING**

- (1) Check the clearance between the snap ring and clutch reaction plate. To check the clearance, hold entire circumference of the clutch reaction plate down with 50 N (11 lbs.) force. If the clearance does not conform to the standard value, select another snap ring to obtain the standard value.

Standard value:**W4A32 0.7 – 0.9 mm (0.028 – 0.035 in.)****F4A33, W4A33 0.8 – 1.0 mm (0.031 – 0.039 in.)****NOTE**

Position the gap of the snap ring approx. 180° away from that of the return spring holding snap ring.

7. REAR CLUTCH

W4A32

DISASSEMBLY AND REASSEMBLY

Disassembly steps

- 1. Seal ring
- ⦿E⦿ 2. Input shaft
- 3. O-ring
- 4. Snap ring
- 5. Thrust race
- 6. Seal ring
- ⦿D⦿ 7. Snap ring
- ⦿C⦿ 8. Clutch reaction plate
- 9. Clutch disc
- ⦿C⦿ 10. Clutch plate
- ⦿C⦿ 11. Clutch pressure plate
- ⦿A⦿ 12. Wave spring
- 13. Return spring
- 14. Rear clutch piston
- 15. Rear clutch retainer
- 16. D-ring
- 17. D-ring

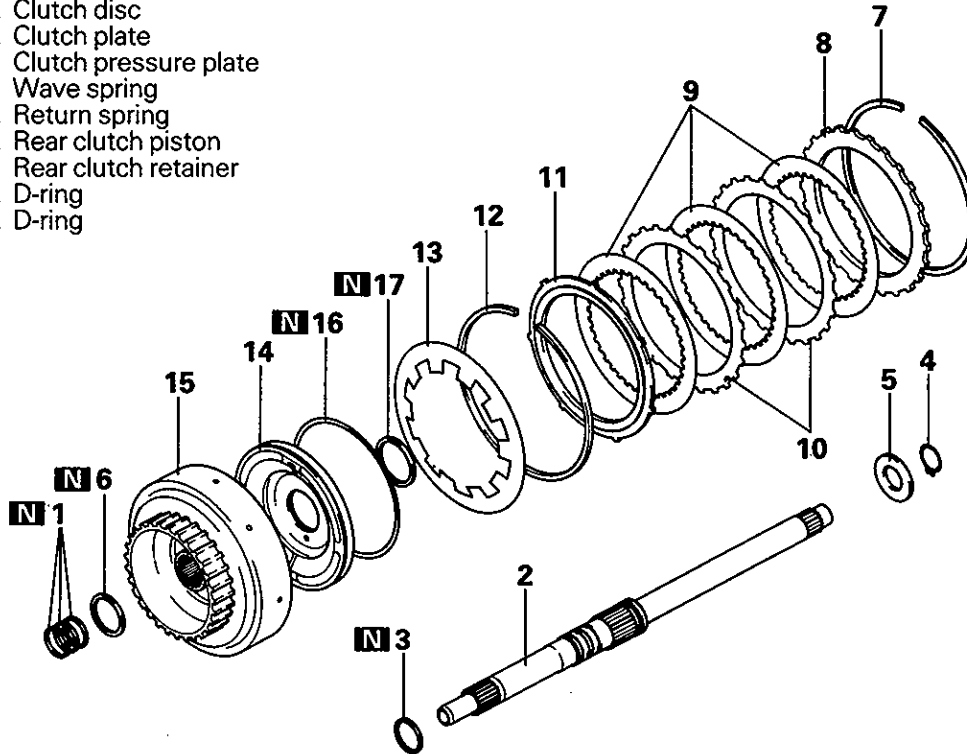

TFA0621

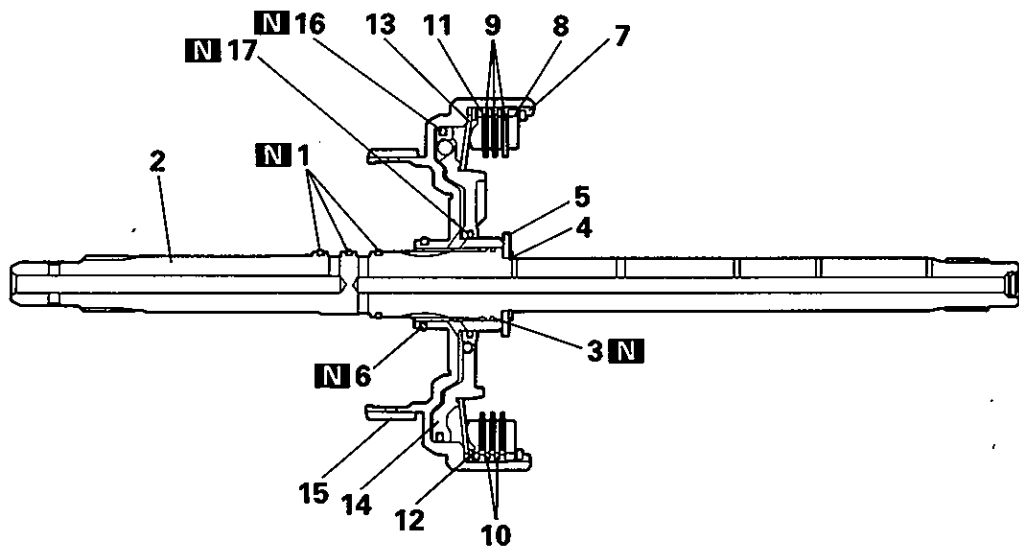

F4A33, W4A33

UP TO MODEL 1992

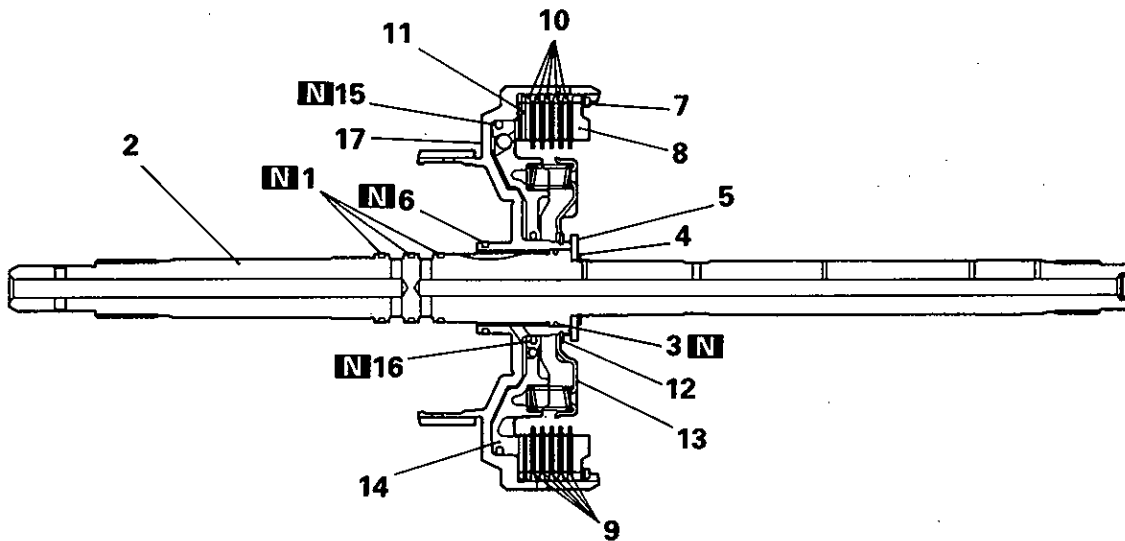
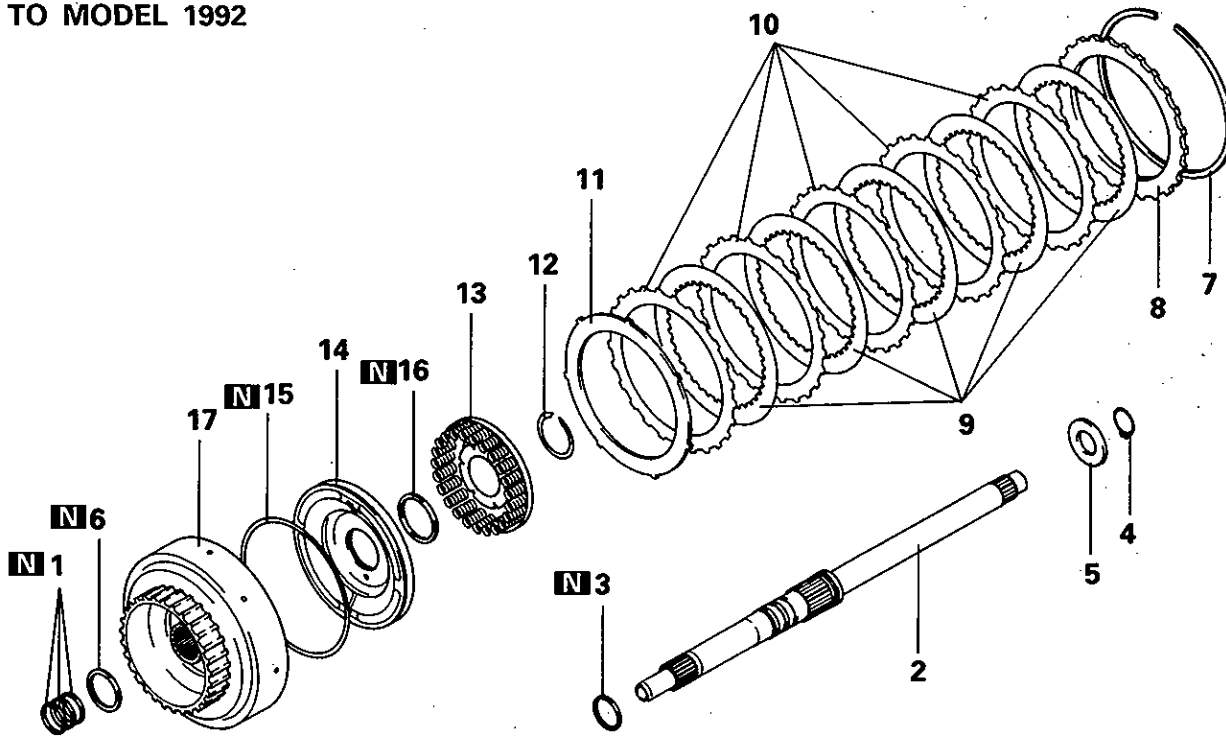

TFA0418

TFA0490

Disassembly steps

- | | |
|------------------------------|--------------------------|
| 1. Seal ring | 10. Clutch plate |
| ↔E↔ 2. Input shaft | 11. Wave spring |
| 3. O-ring | ↔B↔ ↔B↔ 12. Snap ring |
| 4. Snap ring | 13. Return spring |
| 5. Thrust race | 14. Rear clutch piston |
| 6. Seal ring | 15. D-ring |
| ↔D↔ 7. Snap ring | 16. D-ring |
| ↔C↔ 8. Clutch reaction plate | 17. Rear clutch retainer |
| 9. Clutch disc | |

F4A33, W4A33

MODEL 1993

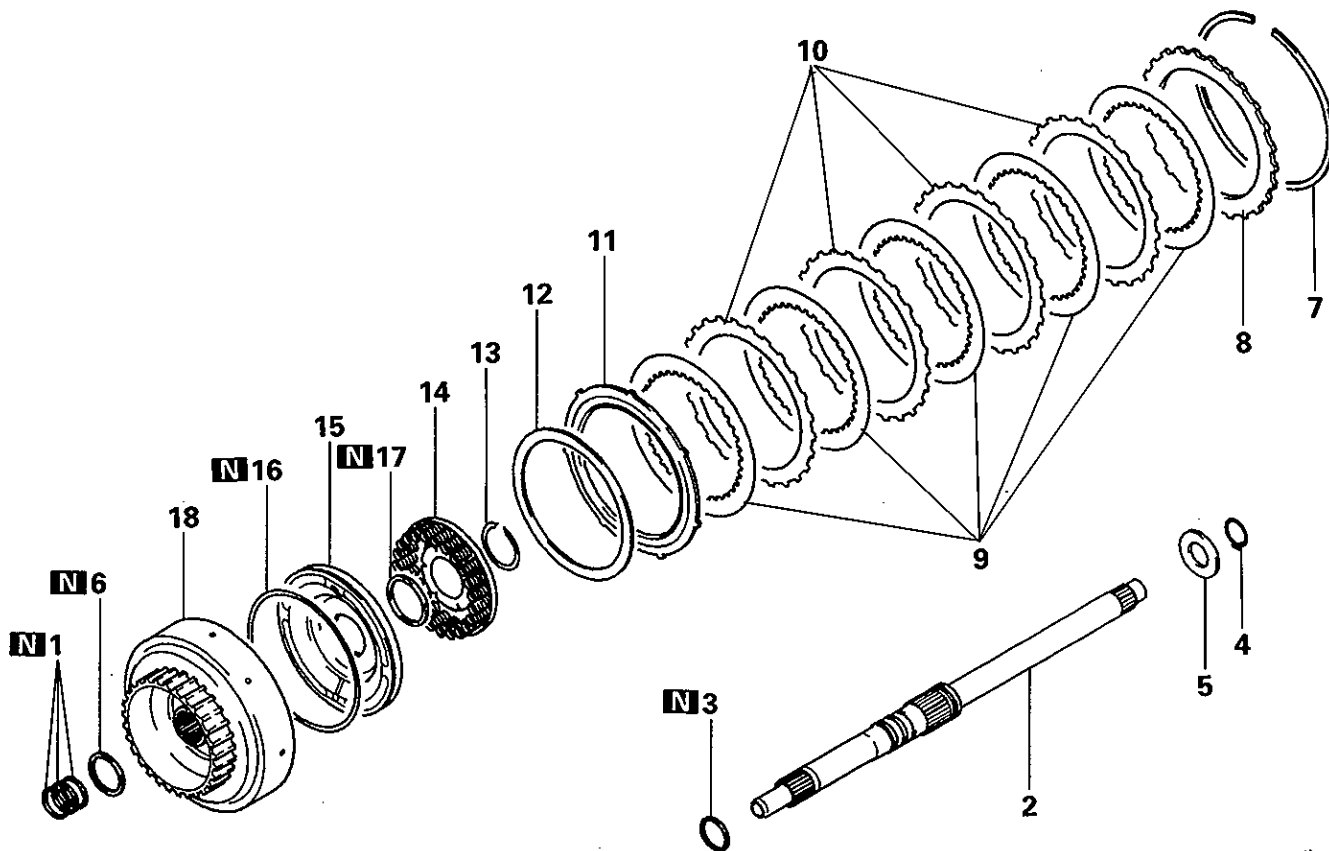

TFA0998

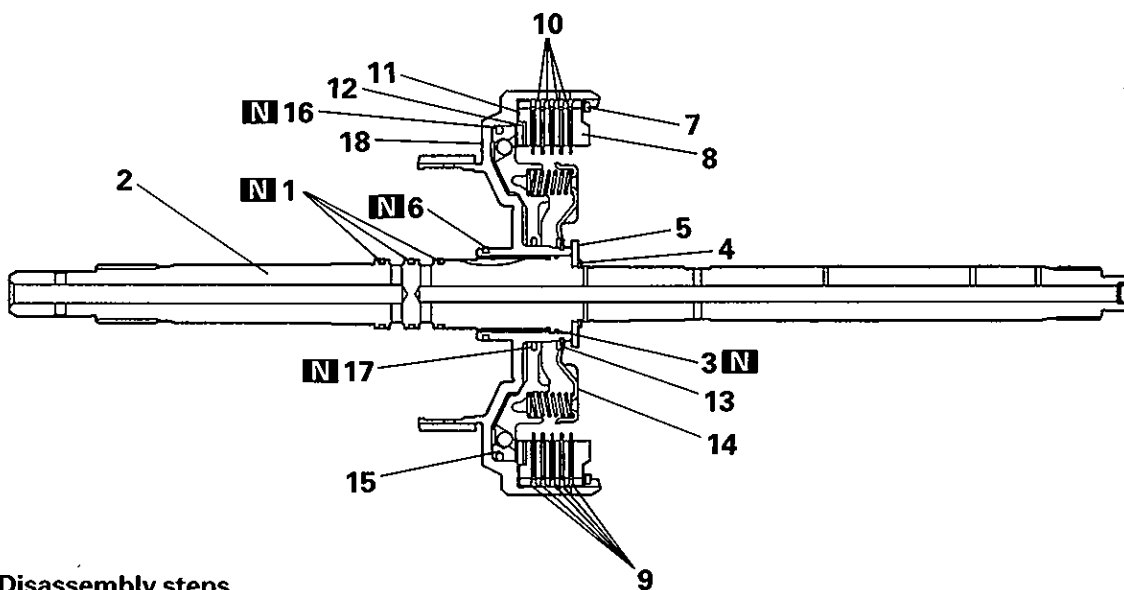

Disassembly steps

- 1. Seal ring
- ↔E↔ 2. Input shaft
- 3. O-ring
- 4. Snap ring
- 5. Thrust race
- 6. Seal ring
- ↔D↔ 7. Snap ring
- ↔C↔ 8. Clutch reaction plate
- 9. Clutch disc

- ↔C↔ 10. Clutch plate
- 11. Clutch pressure plate
- 12. Wave spring
- ↔B↔ ↔B↔ 13. Snap ring
- 14. Return spring
- 15. Rear clutch piston
- 16. D-ring
- 17. D-ring
- 18. Rear clutch retainer

TFA0999

Intentionally blank

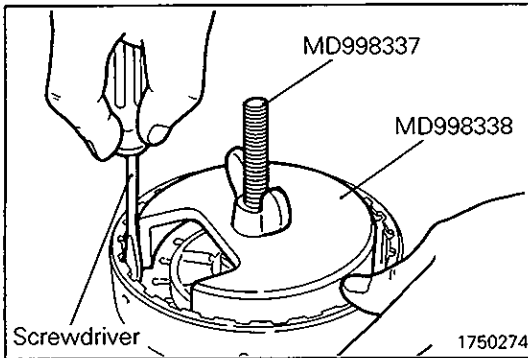
**SERVICE POINTS OF DISASSEMBLY****◁A▷ REMOVAL OF WAVE SPRING**

- (1) Compress the return spring with the special tool.
- (2) Using a screwdriver, remove the wave spring.

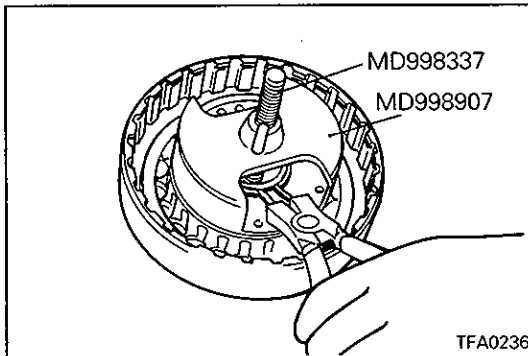
**◁B▷ REMOVAL OF SNAP RING**

- (1) Compress the return spring with the special tool.
- (2) Using a screwdriver, remove the snap ring.

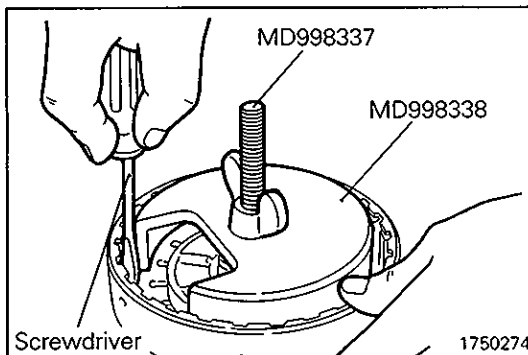
**SERVICE POINTS OF REASSEMBLY****▷A◁ INSTALLATION OF WAVE SPRING**

- (1) Compress the clutch reaction plate with the special tool.
- (2) Install the wave spring.

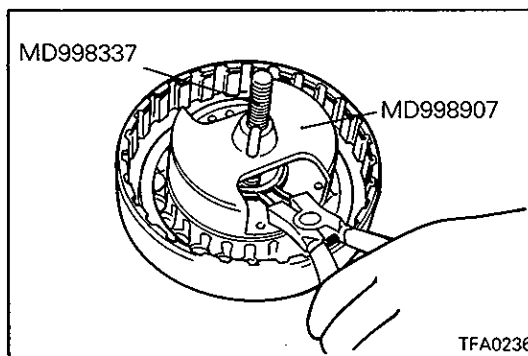
**▷B◁ INSTALLATION OF SNAP RING**

- (1) Compress the clutch reaction plate with the special tool.
- (2) Install the snap ring.

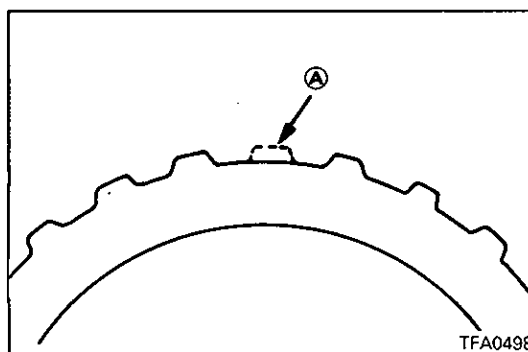
**▷C◁ INSTALLATION OF CLUTCH PRESSURE PLATE / CLUTCH PLATES / CLUTCH REACTION PLATE**

- (1) Install the clutch pressure plate, the clutch plates and the clutch reaction plate with their missing tooth portions (A in the illustration) in alignment.

NOTE

This design allows free flow of automatic transmission fluid thus improving the cooling efficiency of the plates and discs.

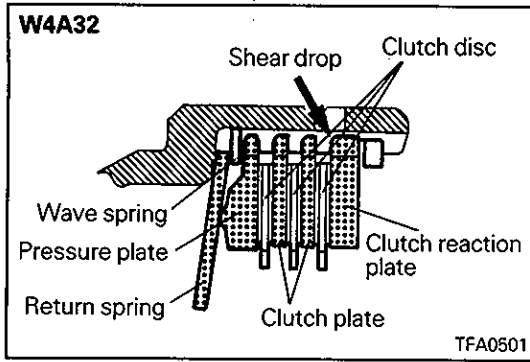

- (2) Install the clutch reaction plate with its shear drop directed as shown in the illustration.

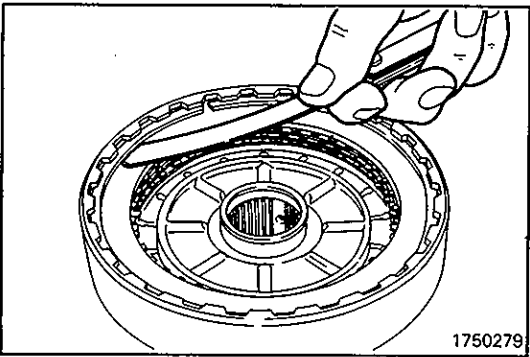
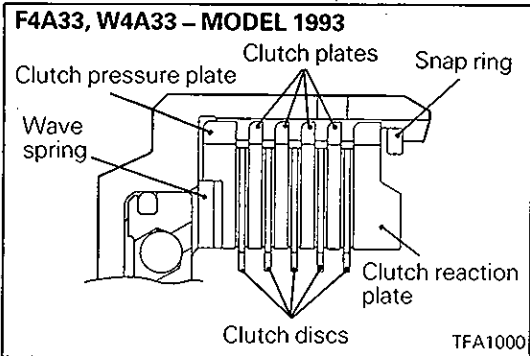
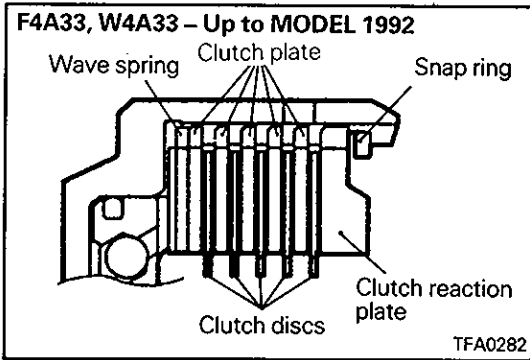

◆D◆ SELECTION OF SNAP RING

- (1) Check the clearance between the snap ring and the clutch reaction plate. To check the clearance, hold entire circumference of the clutch reaction plate down with 50 N (5.0 kg, 11 lbs.) force. If the clearance does not conform to the standard value, select another snap ring to obtain the standard value.

Standard value:

0.4 – 0.6 mm (0.016 – 0.024 in.)	W4A32
1.0 – 1.2 mm (0.039 – 0.047 in.)	F4A33, W4A33

◆E◆ INSTALLATION OF INPUT SHAFT

- (1) Install the input shaft with its oil groove aligned with the oil hole in the rear clutch retainer.

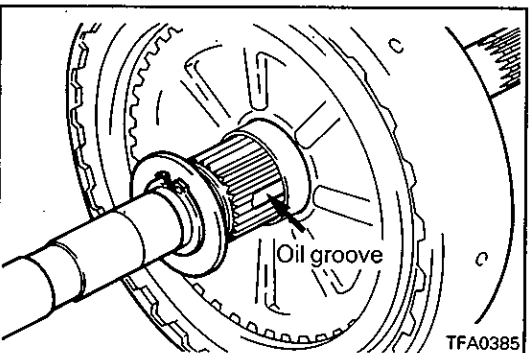

8. END CLUTCH

DISASSEMBLY AND REASSEMBLY

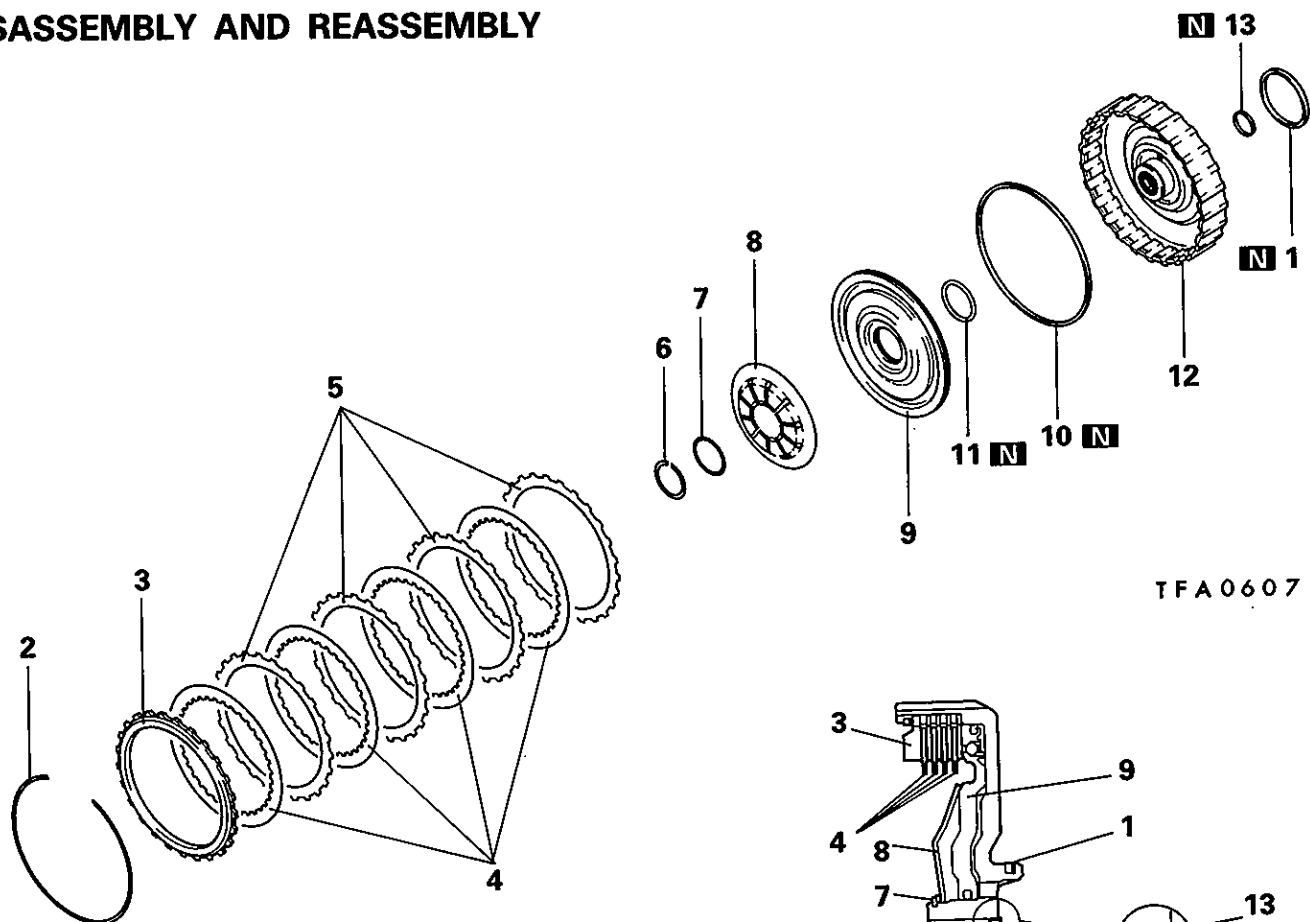

TFA0607

Disassembly steps

- 1. Seal ring
- ↔B↔ 2. Snap ring
- 3. Clutch reaction plate
- 4. Clutch disc
- 5. Clutch plate
- ↔A↔ 6. Snap ring
- 7. Washer
- 8. Return spring
- ↔A↔ 9. End clutch piston
- 10. Oil seal
- 11. D-ring
- 12. End clutch retainer
- 13. Oil seal

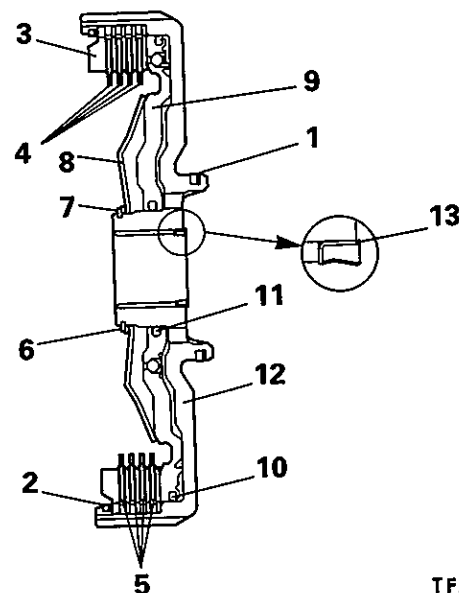

TFA0608

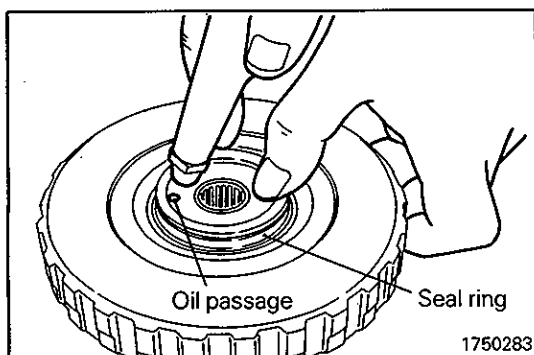

1750283

SERVICE POINT OF DISASSEMBLY

↔A↔ REMOVAL OF END CLUTCH PISTON

- (1) Remove the piston. If it is hard to remove, place the retainer on the workbench with piston side down and blow air through the oil passage in the back of retainer.

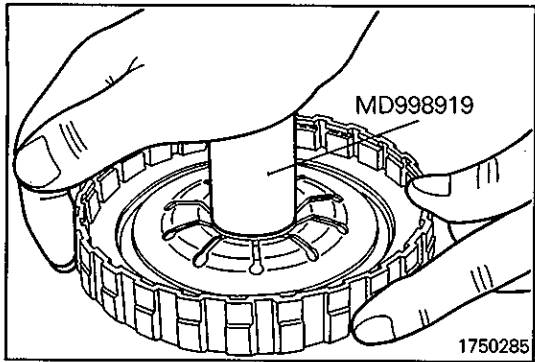

SERVICE POINTS OF REASSEMBLY

◆A◆ INSTALLATION OF SNAP RING

- (1) Using the special tool, fit the snap ring.

Caution

Make sure that the snap ring is fitted in position in the groove.

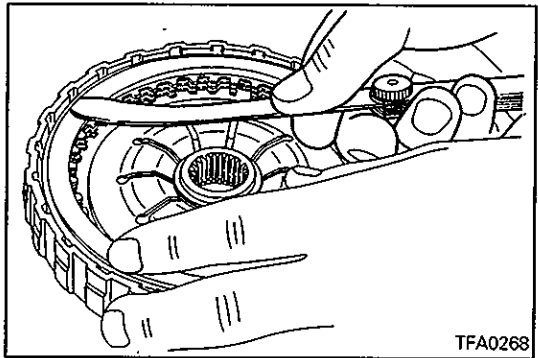

◆B◆ SELECTION OF SNAP RING

- (1) After the snap ring has been installed, check to see if the clearance between the snap ring and clutch reaction plate is to specification. When measuring the clearance, press the entire periphery of the clutch reaction plate with a force of 50 N (11 lbs.). If the clearance does not conform to the specification, reselect the snap ring to obtain the specified clearance.

Standard value: 0.6 – 0.85 mm (0.24 – 0.33 in.)

9. PLANETARY GEAR

W4A32

DISASSEMBLY AND REASSEMBLY

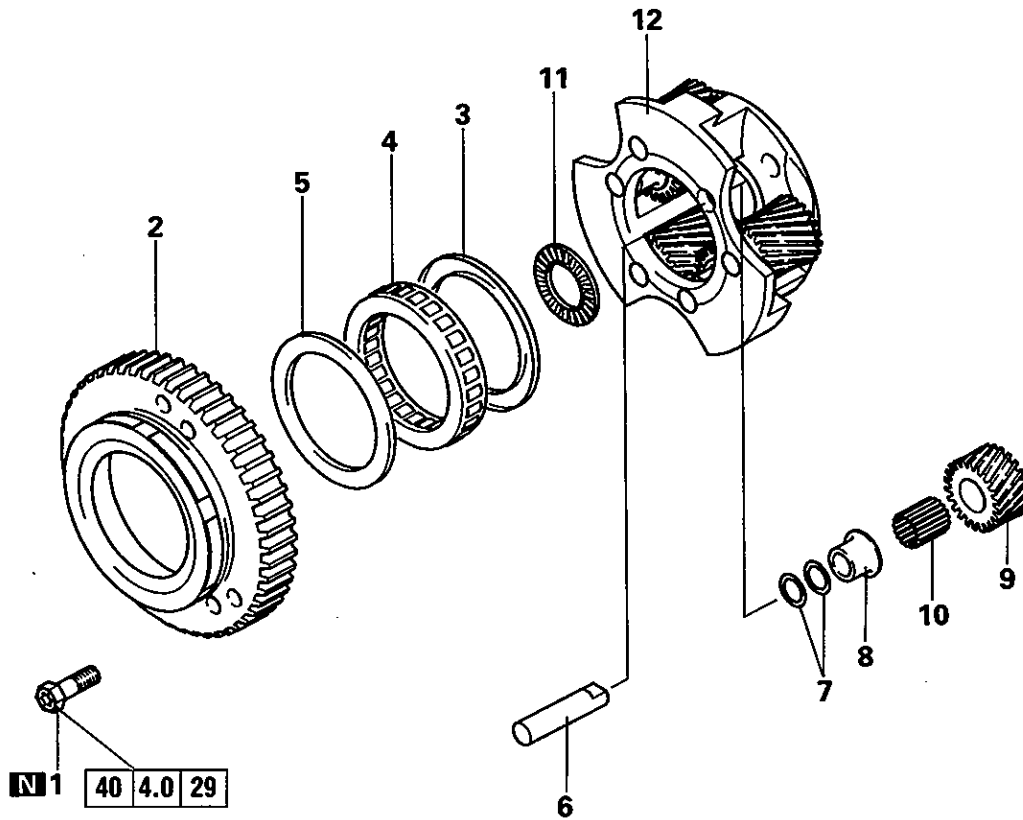

Disassembly steps

1. Bolt
2. One-way clutch outer race
3. End plate
- ◆B◆ 4. One-way clutch
5. End plate
6. Pinion shaft
7. Front thrust washer
8. Spacer bushing
9. Short pinion
10. Roller
- ◇A◇ ◆A◆ 11. Thrust bearing
12. Planetary carrier

TFA0713

F4A33, W4A33

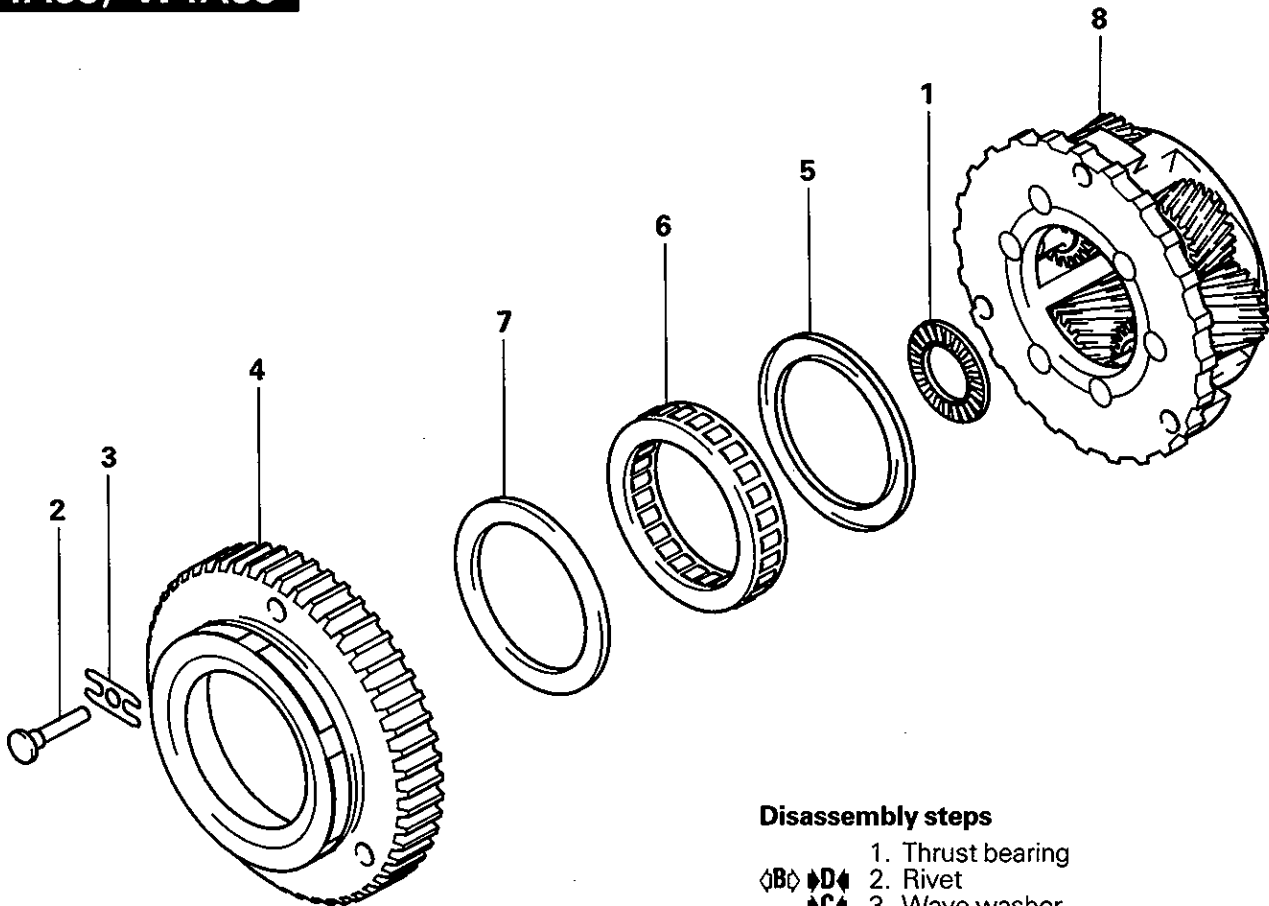
**Disassembly steps**

1. Thrust bearing
2. Rivet
3. Wave washer
4. One-way clutch outer race
5. End plate
6. One-way clutch
7. End plate
8. Planetary carrier

TFA0491

SERVICE POINTS OF DISASSEMBLY**◊A◊ REMOVAL OF THRUST BEARING**

- (1) Remove the only one short pinion. Use care not to drop and lose the 17 rollers in the short pinion. Do not remove the other short pinions.

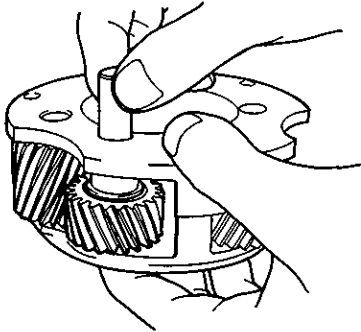

170255

- (2) Remove the thrust bearing.

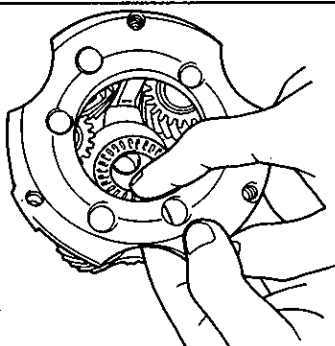

170256

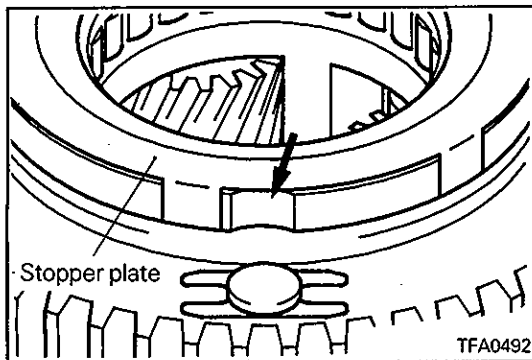

◁B▷ REMOVAL OF RIVET

- (1) Shift the stopper plate to ensure that the rivet head does not hit it.

NOTE

Make sure that the stopper plate claw is not over the groove in the one-way clutch outer race.

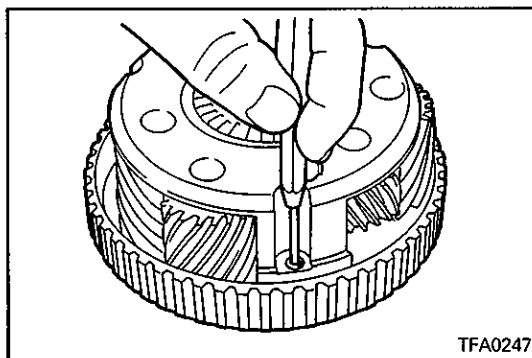

- (2) Using a pin punch, drive out the rivet.

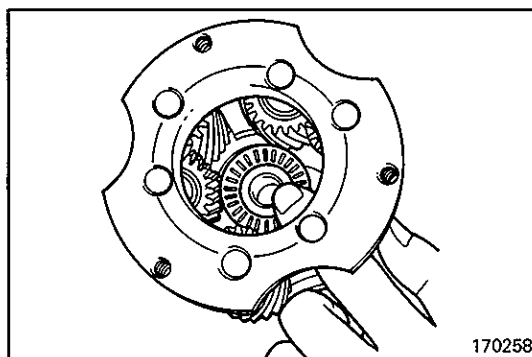

SERVICE POINTS OF REASSEMBLY

▷A◁ INSTALLATION OF THRUST BEARING

- (1) Install a new thrust bearing on the carrier. Make sure that it fits correctly in the spot faced portion of the carrier.

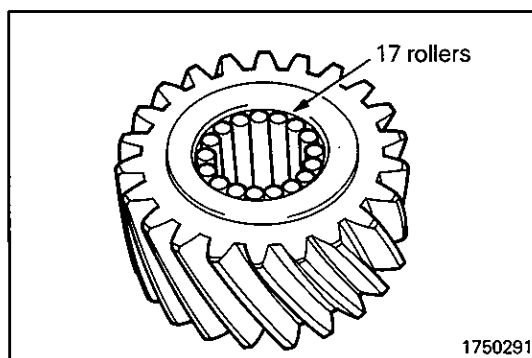

- (2) Apply vaseline unsparingly to the inside surface of the short pinion and attach the 17 rollers on the surface.

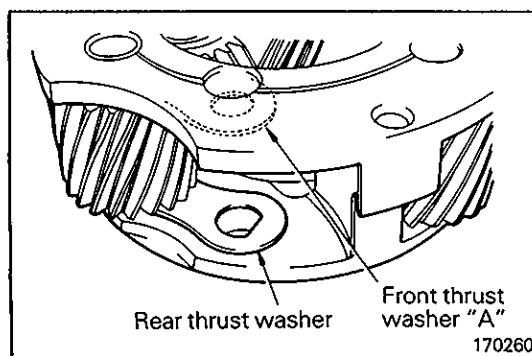

- (3) Line up the holes in both rear thrust washer and front thrust washer "A" with the shaft hole in the carrier.
- (4) Install the short pinion, the spacer bushing and the front thrust washer and align the holes. Use care not to allow the rollers to get out of position.

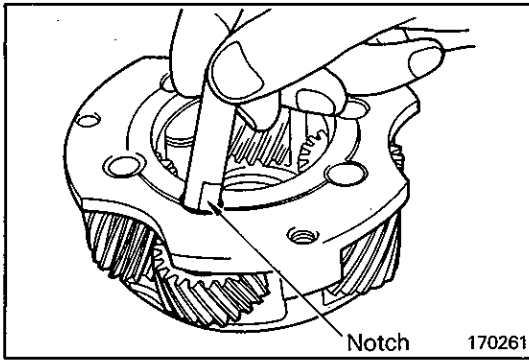

- (5) Insert the pinion shaft. Make sure that the flattened end of pinion shaft is correctly fitted in the hole of the rear thrust plate when the pinion shaft is inserted.

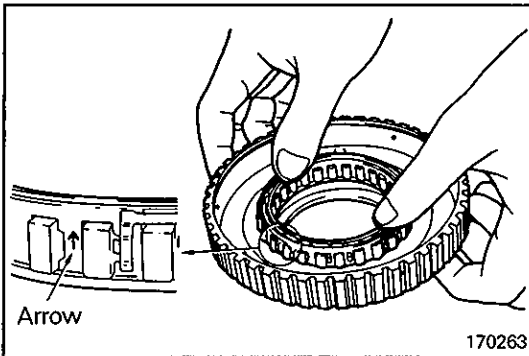

◆B◆ INSTALLATION OF ONE-WAY CLUTCH

- (1) Push the one-way clutch into the outer race. Make sure that arrow on the outside circumference of cage is pointing upward as shown in the illustration when the one-way clutch is pushed in.

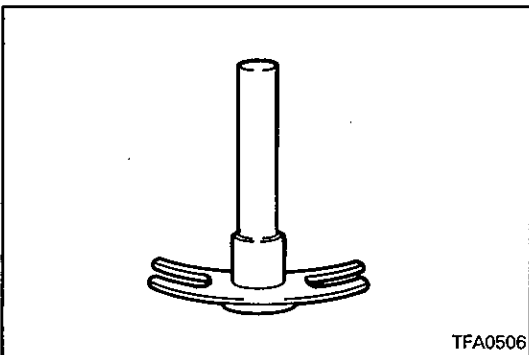

◆C◆ INSTALLATION OF WAVE WASHER

- (1) Fit the wave washer on the rivet so that its concave side will face the outer race side.

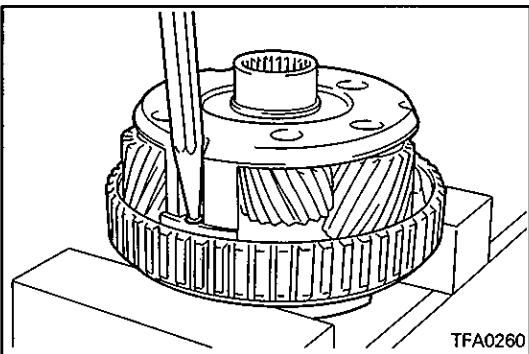

◆D◆ INSTALLATION OF RIVET

- (1) Stake the rivet using a punch and press.

NOTE

- (1) Use a punch with a 60° tip angle.
 (2) Stake the rivet with a load of 11,000 – 13,000 N (1,100 – 1,300 kg, 2,425 – 2,866 lbs.).

10. ANNULUS GEAR AND TRANSFER DRIVE GEAR SET DISASSEMBLY AND REASSEMBLY

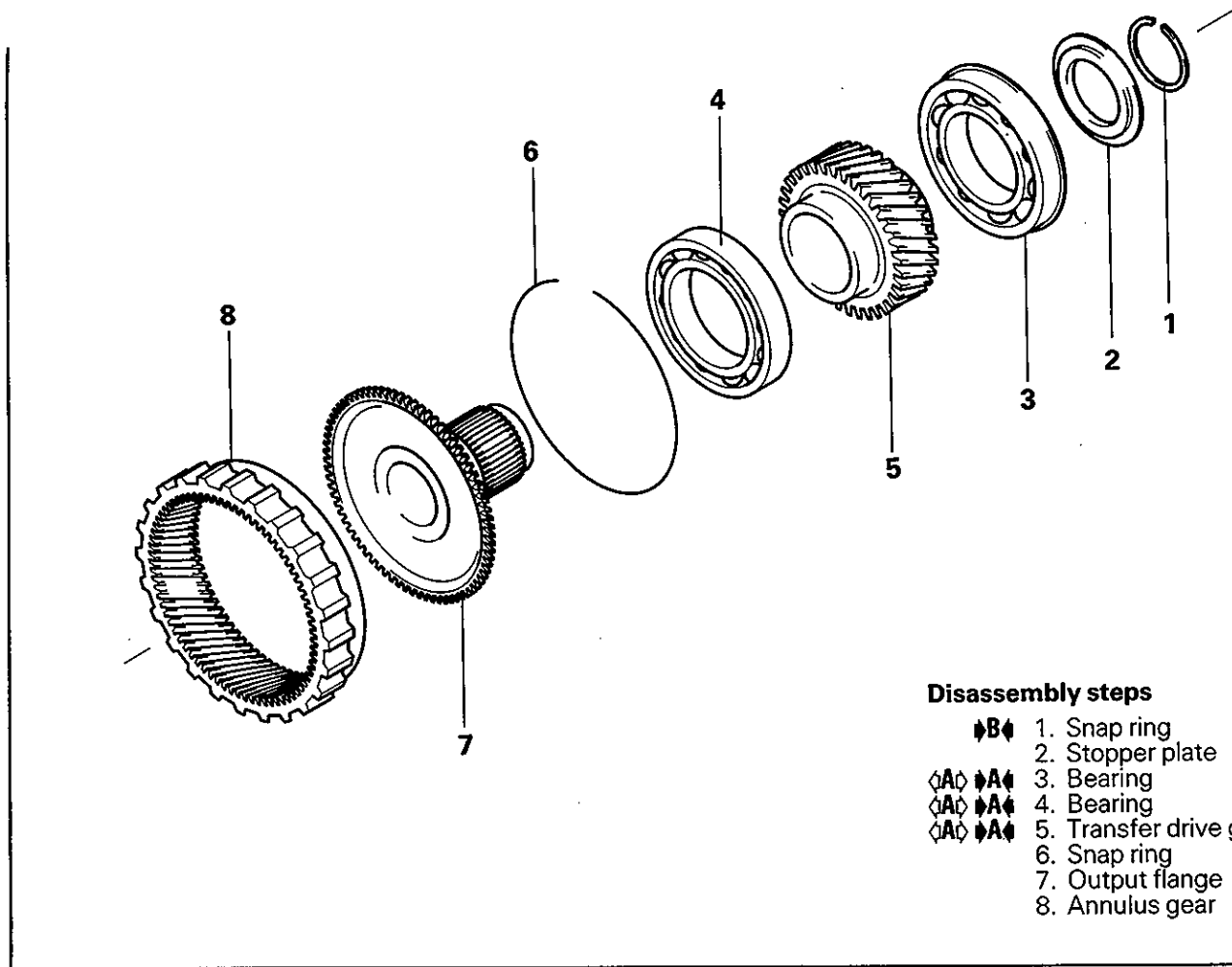

Disassembly steps

- ⚡ 1. Snap ring
- 2. Stopper plate
- ⚡ 3. Bearing
- ⚡ 4. Bearing
- ⚡ 5. Transfer drive gear
- 6. Snap ring
- 7. Output flange
- 8. Annulus gear

TFA0262

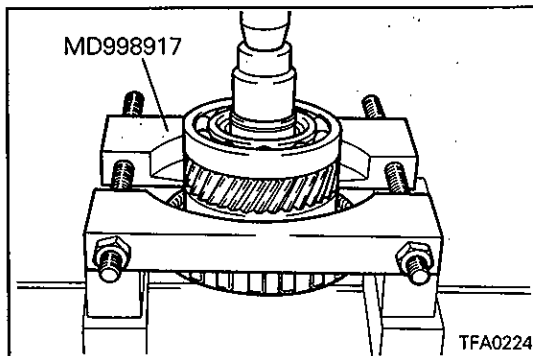

SERVICE POINTS OF DISASSEMBLY

⚡ REMOVAL OF BEARING / TRANSFER DRIVE GEAR

- (1) Using the special tool, remove the transfer drive gear together with the two bearings from the output flange.

Caution

- Install the special tool in position between the output flange and the bearings.

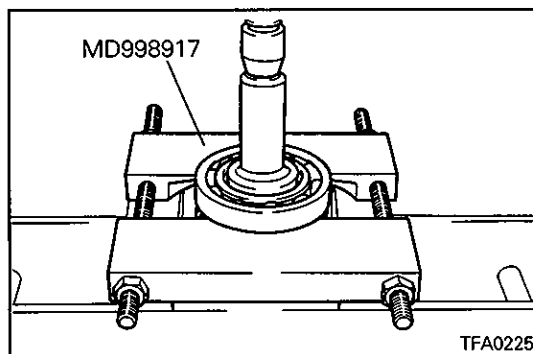

- (2) Using the special tool, remove the bearings from both sides of the transfer drive gear.

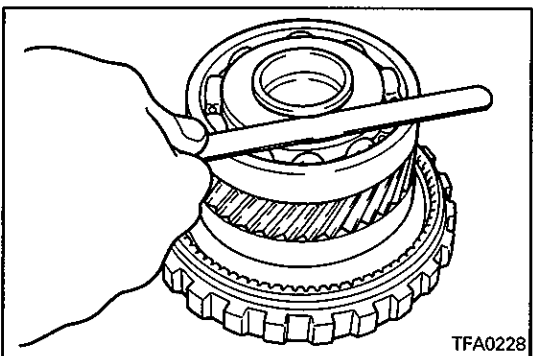
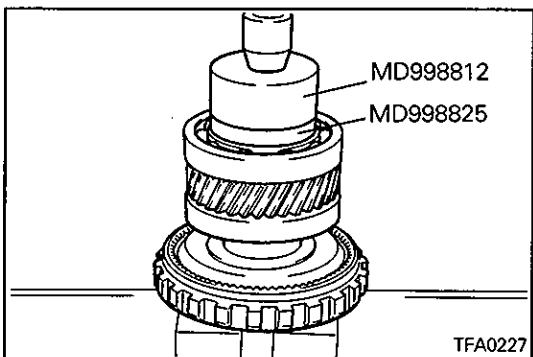
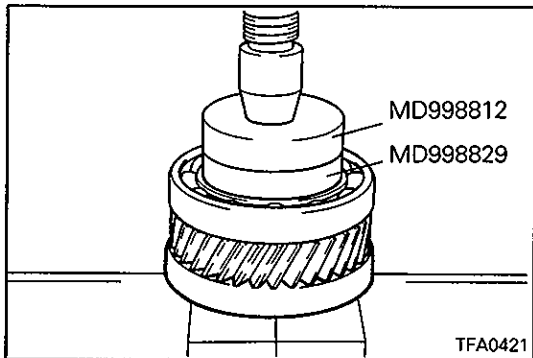
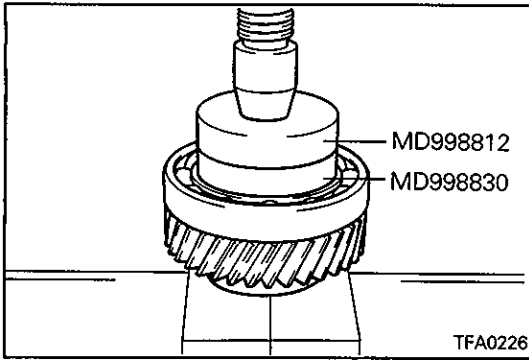

SERVICE POINTS OF REASSEMBLY

▶A▶ INSTALLATION OF TRANSFER DRIVE GEAR / BEARING

- (1) Using the special tool, press-fit the bearings on both sides of the transfer drive gear.

- (2) Using the special tool, install the transfer drive gear on the output flange.

▶B▶ SELECTION OF SNAP RING

- (1) Measure the snap ring groove clearance and select the appropriate spacer to obtain the specified end play.

Standard value: 0 – 0.09 mm (0 – 0.0035 in.)

11. DIFFERENTIAL

DISASSEMBLY AND REASSEMBLY

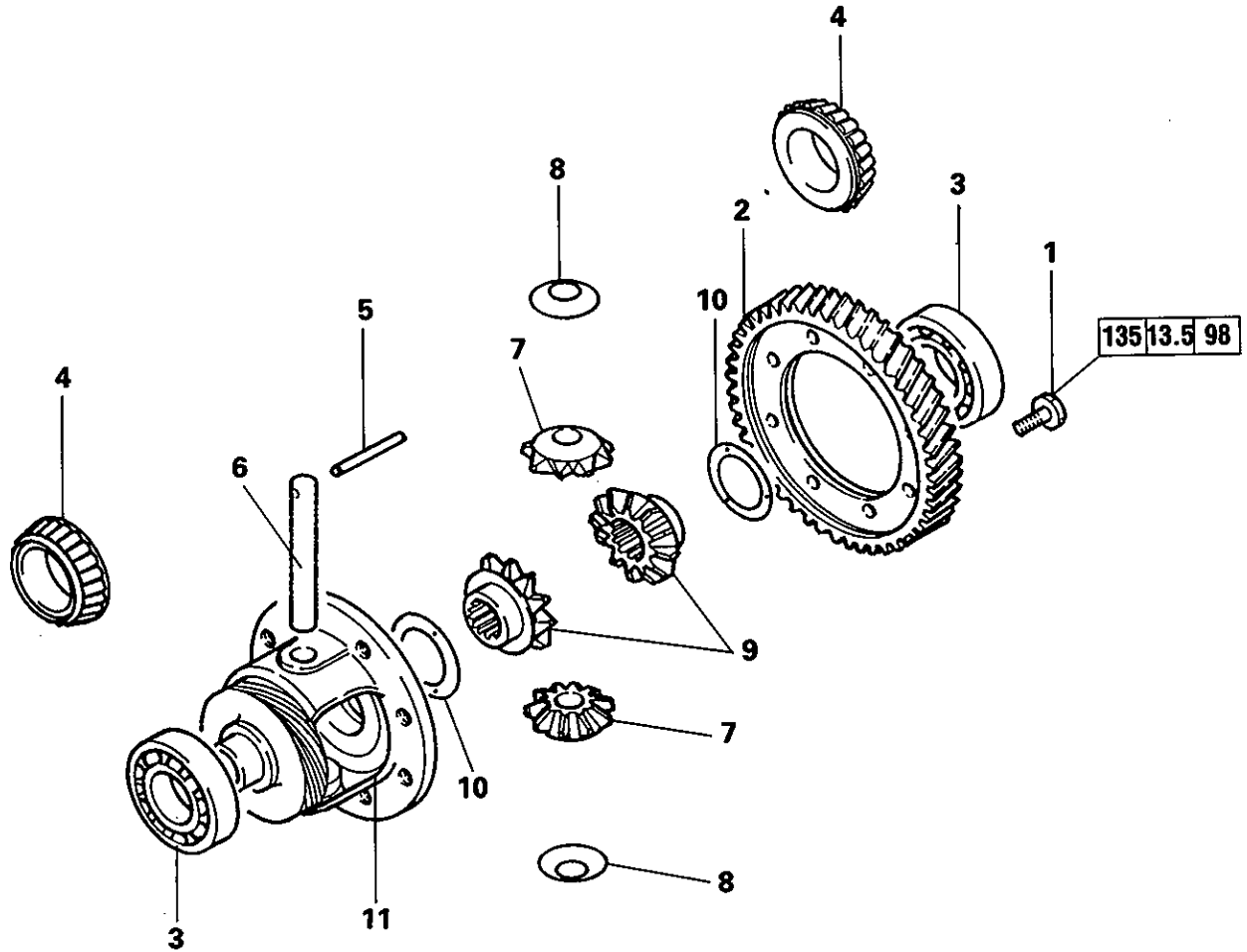

Disassembly steps

- ◆E◆ 1. Bolt
- ◆E◆ 2. Differential drive gear
- ◆A◆◆D◆ 3. Ball bearing (W4A32, W4A33)
- ◆B◆◆C◆ 4. Taper roller bearing (F4A33)
- ◆C◆◆B◆ 5. Lock pin
- ◆A◆◆A◆ 6. Pinion shaft
- ◆A◆◆A◆ 7. Pinion
- ◆A◆◆A◆ 8. Washer
- ◆A◆◆A◆ 9. Side gear
- ◆A◆◆A◆ 10. Spacer
- ◆A◆◆A◆ 11. Differential case

TFA0263

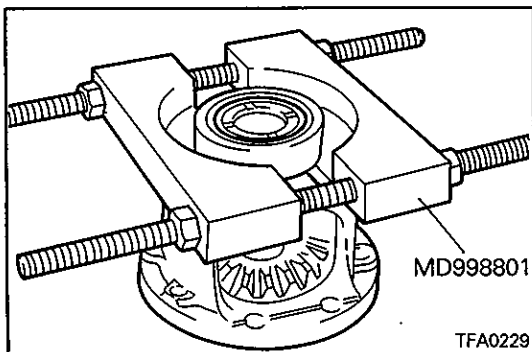

TFA0229

SERVICE POINTS OF DISASSEMBLY

◆A◆ REMOVAL OF BALL BEARING

(1) Use the special tool to remove the ball bearing.

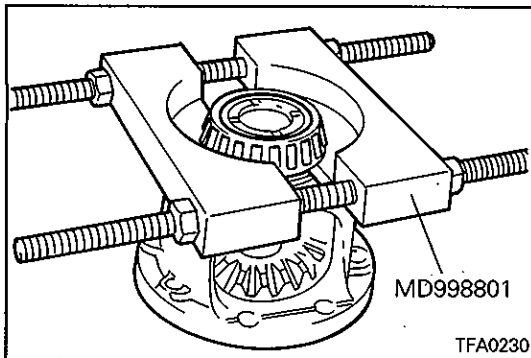

◁B▷ REMOVAL OF TAPER ROLLER BEARING

- (1) Use the special tool to remove the taper roller bearing.

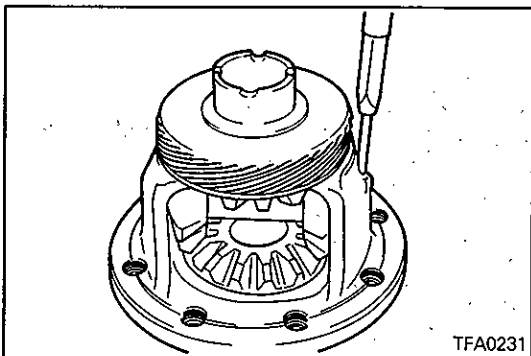

◁C▷ REMOVAL OF LOCK PIN

- (1) Using a pin punch, drive out the lock pin.

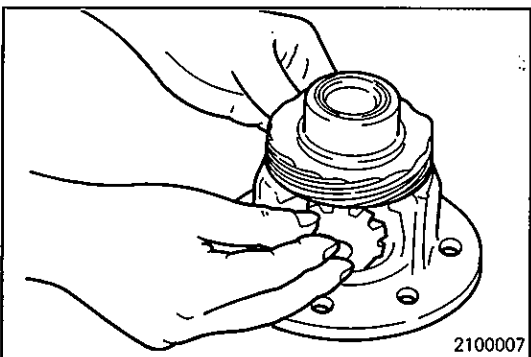

SERVICE POINTS OF REASSEMBLY

▶A▶ INSTALLATION OF SPACER / SIDE GEAR WASHER / PINION / PINION SHAFT

- (1) Fit the spacer to the back face of the side gear, then install the gear into the differential case.
- (2) Fit the washer to the back of each pinion and rotate the two pinions at the same time into position to mesh with the side gear.

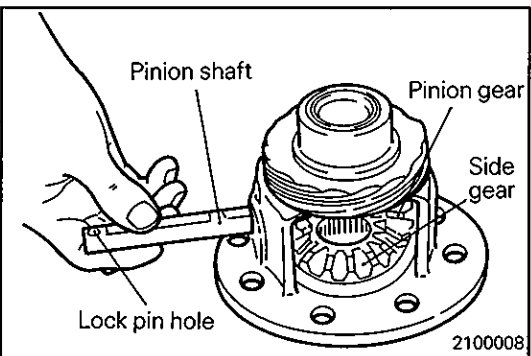

- (3) Insert the pinion shaft.

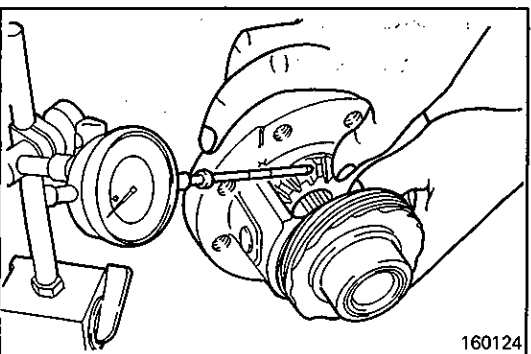

- (4) Measure the backlash between the side gear and the pinion.

Standard value: 0.025 – 0.150 mm (0.001 – 0.0059 in.)

- (5) If the backlash does not conform to the specification, select an appropriate spacer and disassemble and reassemble the gears as necessary.

NOTE

Adjust so that the backlash is the same on both side gears.

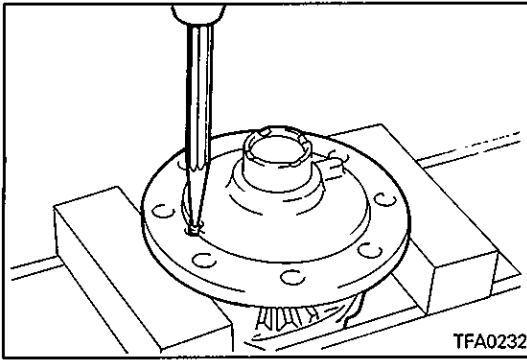

◆B◆ INSTALLATION OF LOCK PIN

- (1) Align the lock pin hole in pinion shaft with that in the case and install the lock pin.

Caution

1. Do not reuse lock pins.
2. Press the lock pin to a level lower than the surface of the differential case flange.
3. Press-fitting load should be over 5,000 N (500 kg, 1,100 lbs.)

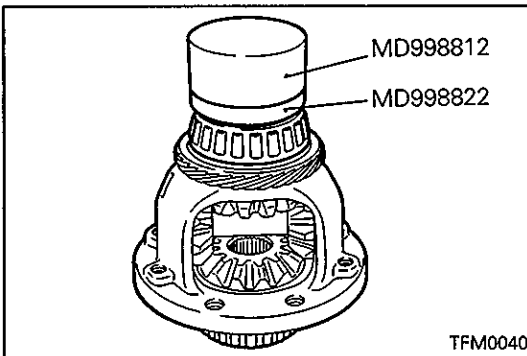

◆C◆ INSTALLATION OF TAPER ROLLER BEARING

- (1) Using the special tool, press-fit the bearings into both sides of the differential case.

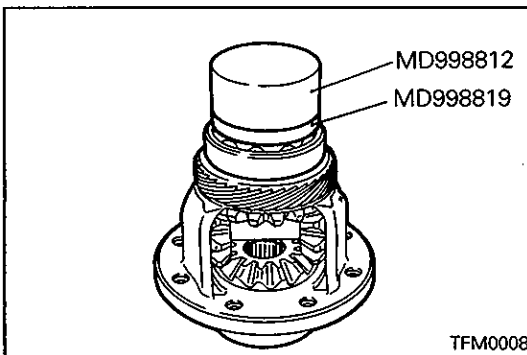

◆D◆ INSTALLATION OF BALL BEARING

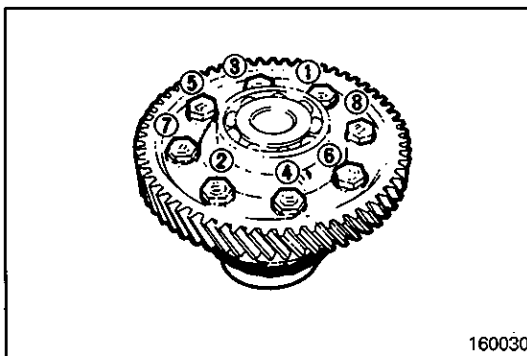

◆E◆ INSTALLATION OF BOLTS

- (1) Apply ATF to the differential drive gear bolts, install and tighten them to the specified torque in the order shown in the figure.

Differential drive gear bolt:
135 Nm (13.5 kgm, 98 ft.lbs.)

NOTES

2. KICKDOWN SERVO DISASSEMBLY AND REASSEMBLY

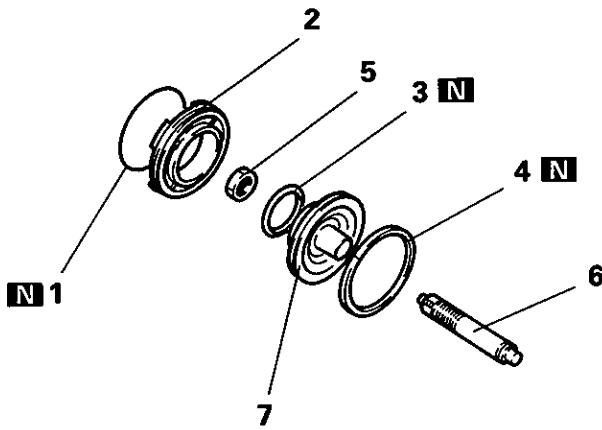

Disassembly steps

1. O-ring
2. Kickdown servo sleeve
3. D-ring
4. Seal ring
5. Lock nut
6. Kickdown servo rod
7. Kickdown servo piston

1750299

NOTES

13. LOW REVERSE BRAKE DISASSEMBLY AND REASSEMBLY

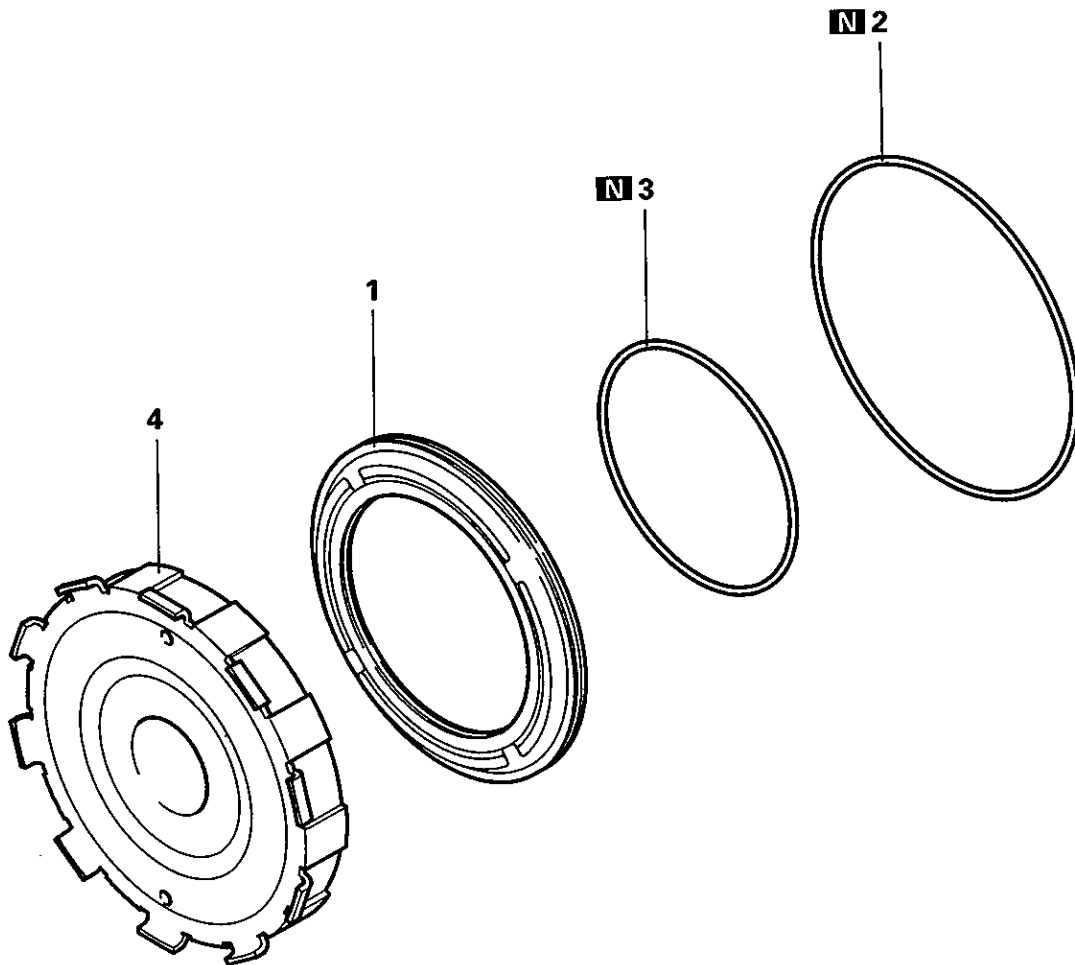

Disassembly steps

1. Low-reverse brake piston
2. D-ring
3. D-ring
4. Center support

TFA0386

NOTES

14. SPEEDOMETER GEAR DISASSEMBLY AND REASSEMBLY

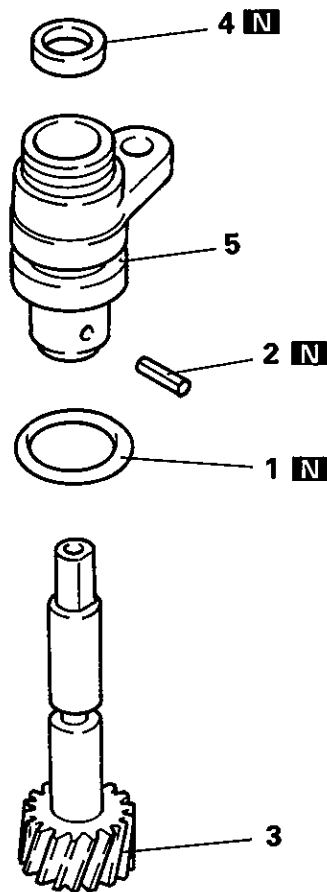

Disassembly steps

- 1. O-ring
- ▶▶ 2. Spring pin
- 3. Driven gear
- 4. Oil seal
- 5. Sleeve

201078

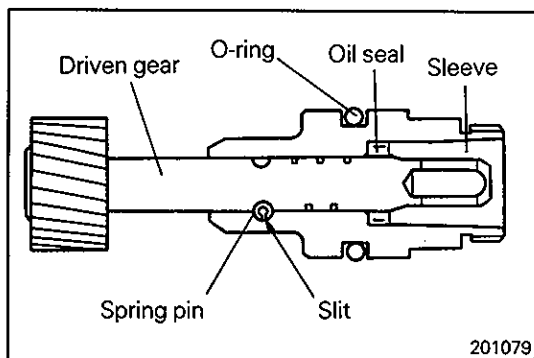

201079

SERVICE POINT OF REASSEMBLY

▶▶ **INSTALLATION OF SPRING PIN**

- (1) Drive a new spring pin into the sleeve. Make sure that the slit in the spring pin does not face the gear.

NOTES

15. VALVE BODY

DISASSEMBLY AND REASSEMBLY

Viewed from A

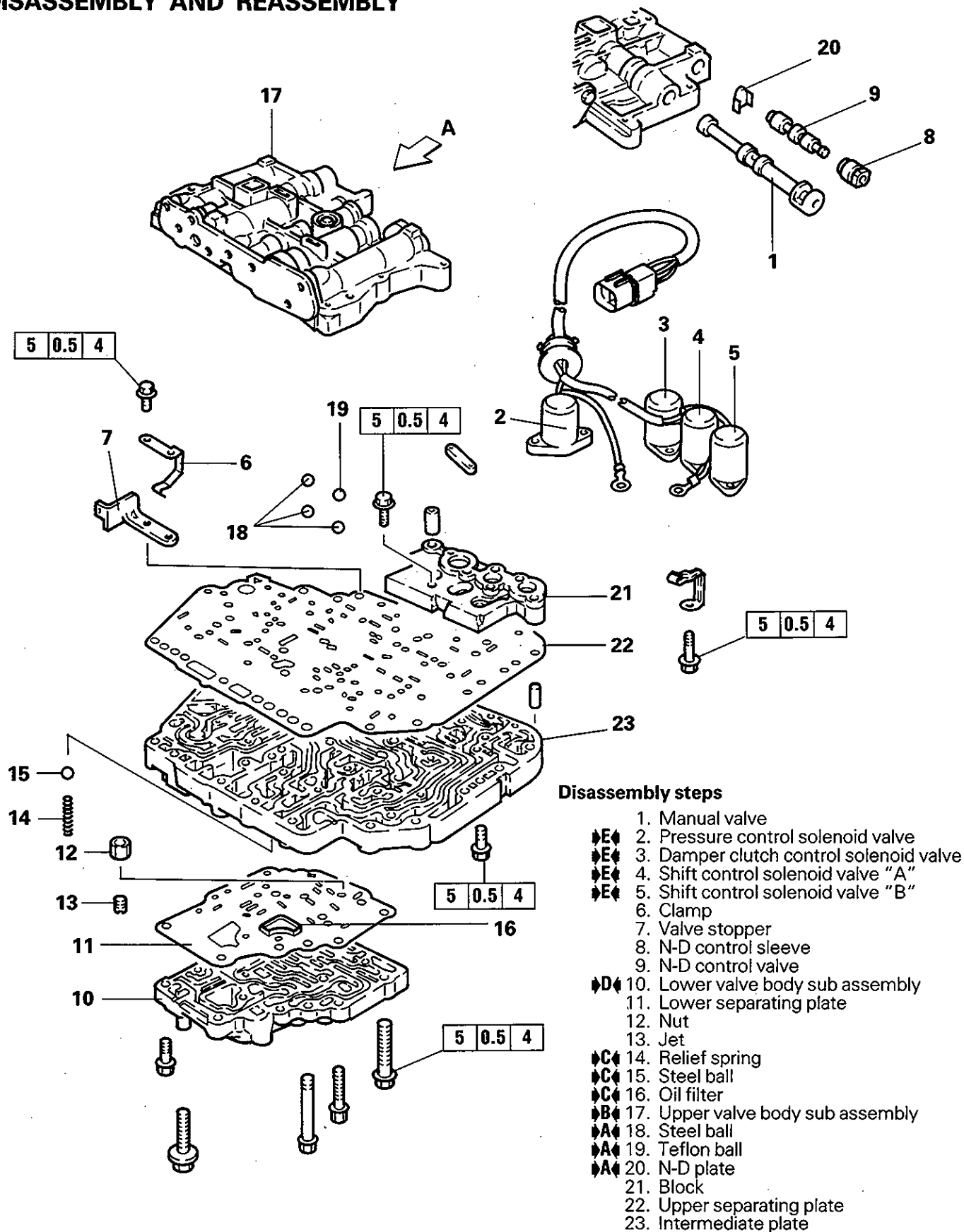

Disassembly steps

1. Manual valve
- ▶E◀ 2. Pressure control solenoid valve
- ▶E◀ 3. Damper clutch control solenoid valve
- ▶E◀ 4. Shift control solenoid valve "A"
- ▶E◀ 5. Shift control solenoid valve "B"
6. Clamp
7. Valve stopper
8. N-D control sleeve
9. N-D control valve
- ▶D◀ 10. Lower valve body sub assembly
11. Lower separating plate
12. Nut
13. Jet
- ▶C◀ 14. Relief spring
- ▶C◀ 15. Steel ball
- ▶C◀ 16. Oil filter
- ▶B◀ 17. Upper valve body sub assembly
- ▶A◀ 18. Steel ball
- ▶A◀ 19. Teflon ball
- ▶A◀ 20. N-D plate
21. Block
22. Upper separating plate
23. Intermediate plate

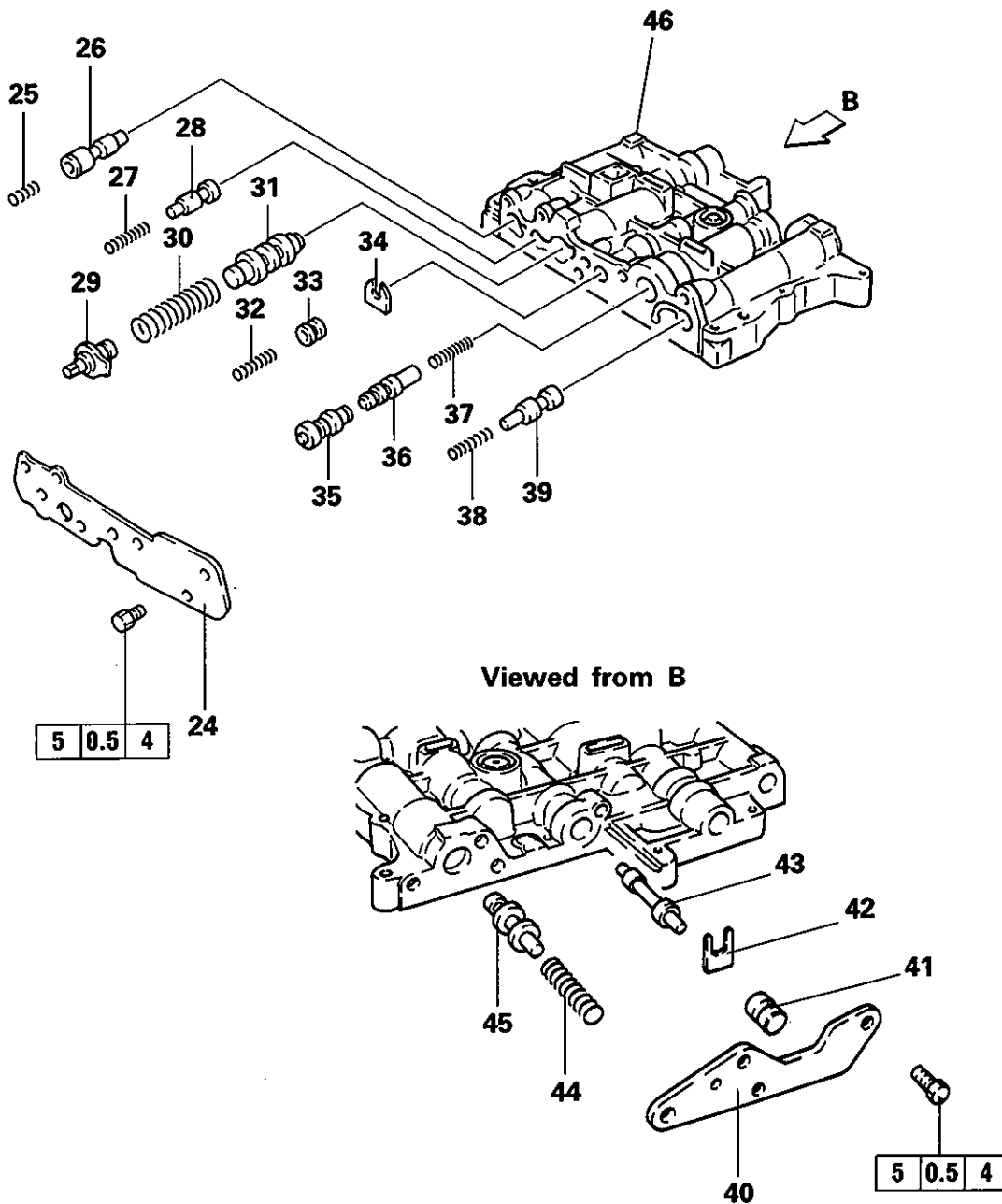

Disassembly steps

- 24. Front end cover
- 25. Pressure control spring
- 26. Pressure control valve
- 27. Torque converter control spring
- 28. Torque converter control valve
- 29. Adjusting screw
- 30. Regulator spring
- 31. Regulator valve
- 32. Shift control spring
- ◆A◆ 33. Stopper plate
- 34. Shift control plug
- 35. Rear clutch exhaust valve A
- 36. Rear clutch exhaust valve B
- 37. Rear clutch exhaust spring
- 38. 2-3/4-3 shift spring
- 39. 2-3/4-3 shift valve
- 40. Rear end cover
- 41. Shift control plug B
- ◆A◆ 42. Stopper plate
- 43. Shift control valve
- 44. 1-2 shift spring
- 45. 1-2 shift valve
- 46. Upper valve body

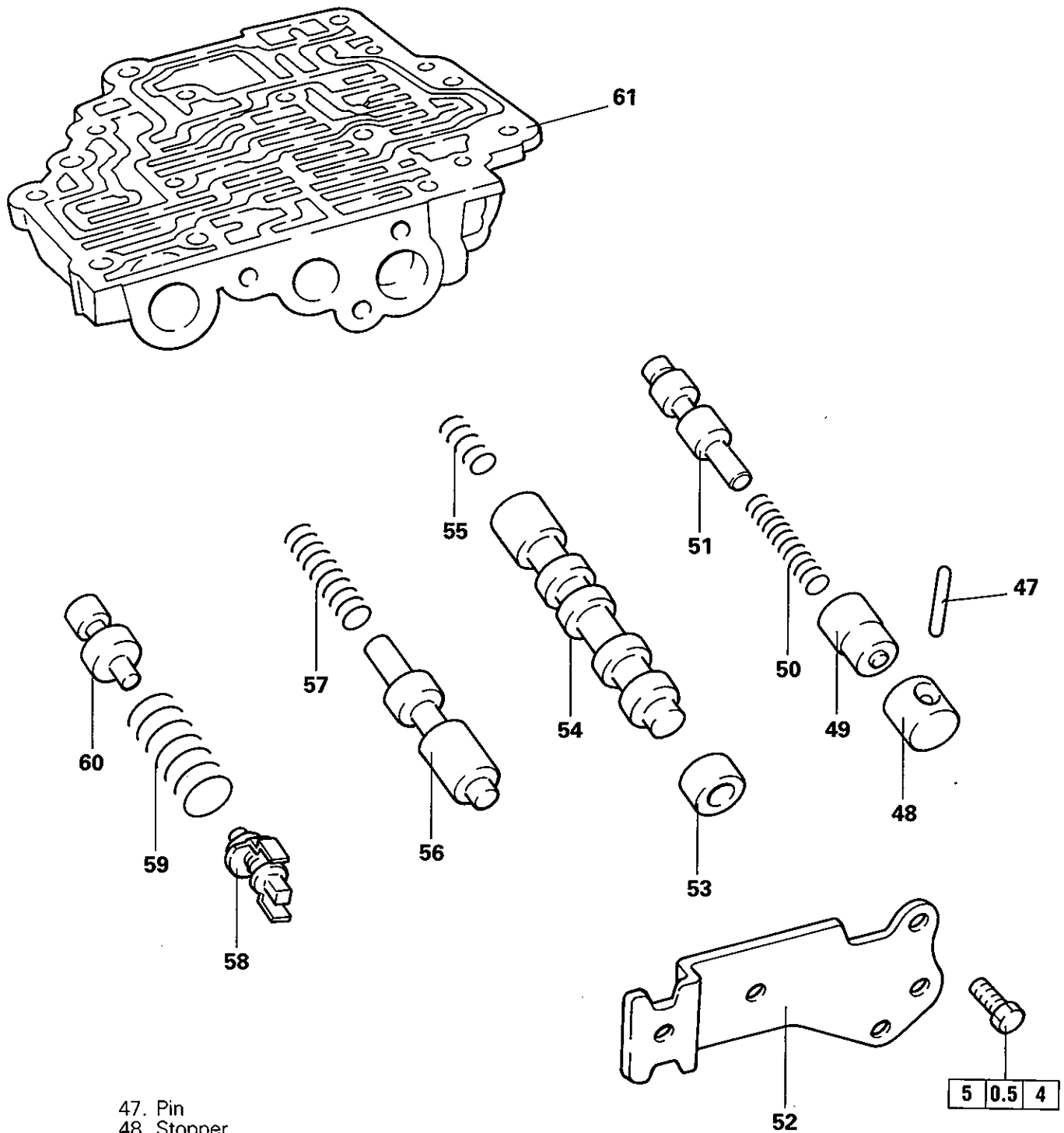

- 47. Pin
- 48. Stopper
- 49. End clutch plug
- 50. End clutch spring
- 51. End clutch valve
- 52. End cover
- 53. Damper clutch control sleeve
- 54. Damper clutch control valve
- 55. Damper clutch control spring
- 56. N-R control valve
- 57. N-R control spring
- 58. Adjusting screw
- 59. Reducing spring
- 60. Reducing valve
- 61. Lower valve body

5	0.5	4
---	-----	---

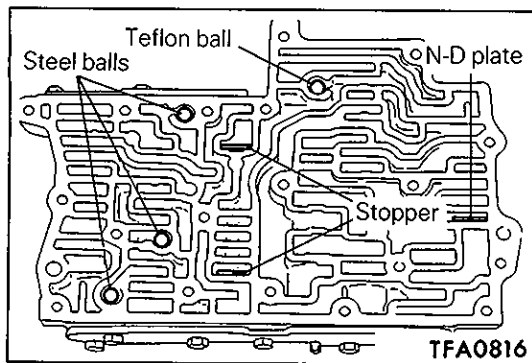

▶A◀ LOCATION OF STOPPER PLATE / N-D PLATE / TEFLON BALL / STEEL BALL

- (1) Install the stopper plates, N-D plate, teflon ball, and steel balls into the upper valve body as shown.

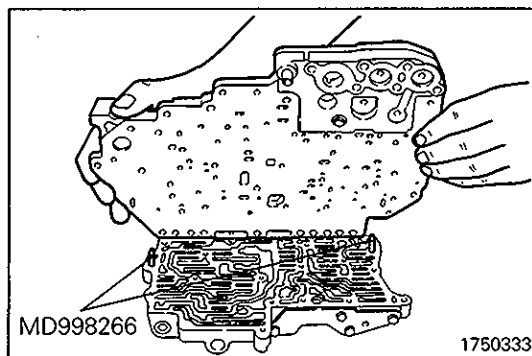

▶B◀ INSTALLATION OF UPPER VALVE BODY SUB ASSEMBLY

- (1) Install the special tools and secure the upper separating plate on the intermediate plate with eight mounting bolts. Then, remove the special tools.

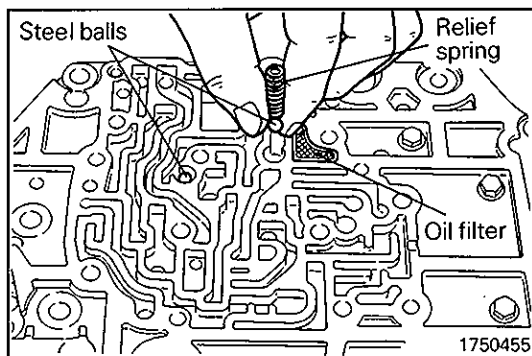

▶C◀ INSTALLATION OF OIL FILTER / STEEL BALL / RELIEF SPRING

- (1) Install the oil filter, two steel balls, and spring in the intermediate plate.

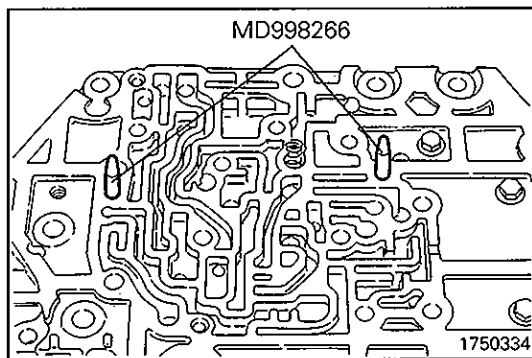

▶D◀ INSTALLATION OF LOWER VALVE BODY SUB ASSEMBLY

- (1) Install the special tools on the intermediate plate.

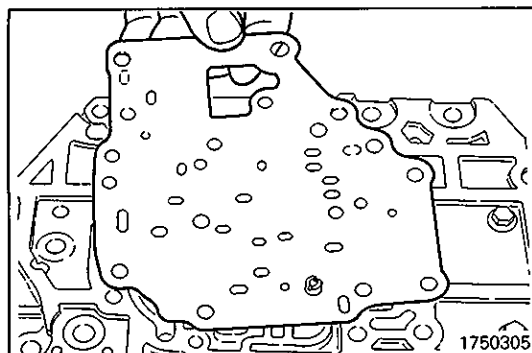

- (2) Install the lower separating plate.

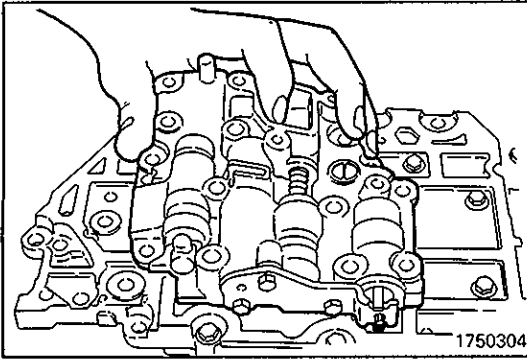

- (3) Secure the lower valve body with mounting bolts and then remove the special tool.

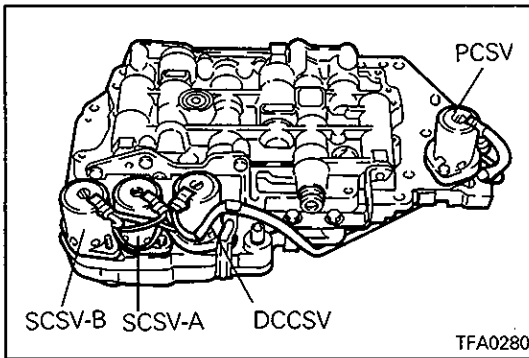

▶E◀ INSTALLATION OF SOLENOID VALVE ASSEMBLY

- (1) Install the solenoid valves as shown.

NOTES

16. TRANSFER SHAFT (F4A33)

DISASSEMBLY AND REASSEMBLY

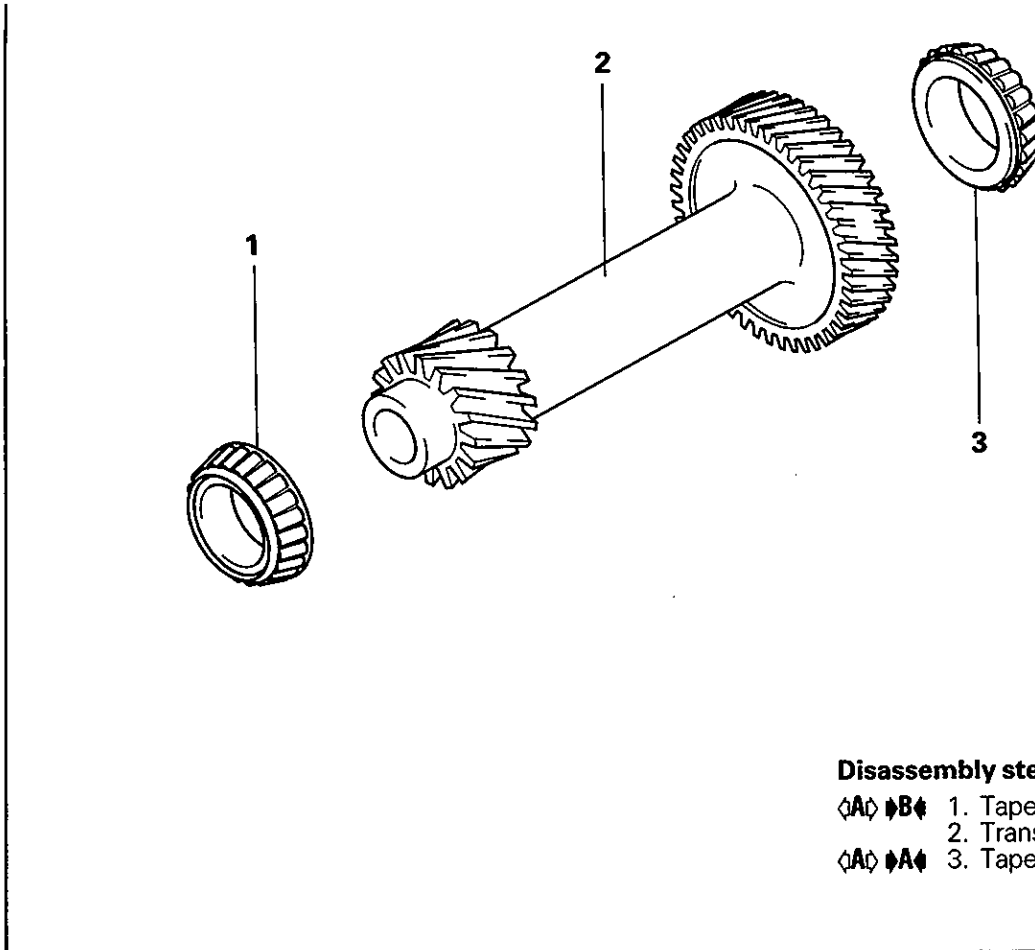

TFA0322

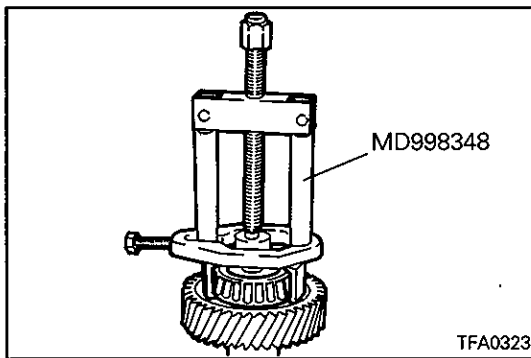

SERVICE POINT OF DISASSEMBLY

◊A◊ REMOVAL OF TAPER ROLLER BEARING

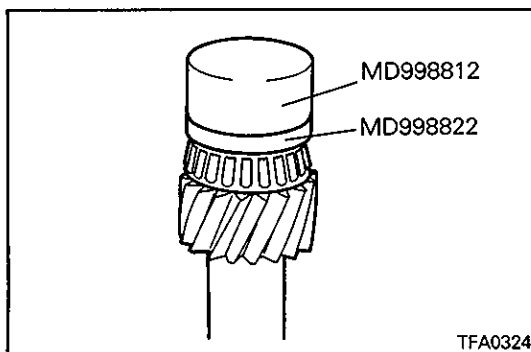

SERVICE POINTS OF REASSEMBLY

◊A◊ INSTALLATION OF TAPER ROLLER BEARING

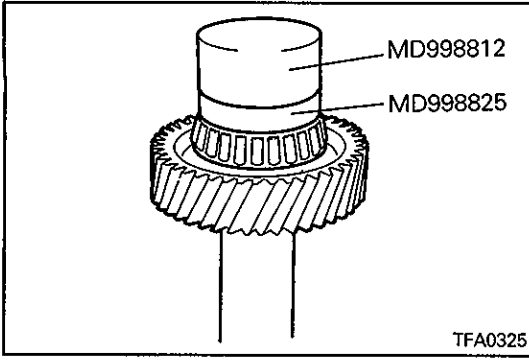

⇨B⇩ INSTALLATION OF TAPER ROLLER BEARING

17. CENTER DIFFERENTIAL (W4A32, W4A33)

DISASSEMBLY AND REASSEMBLY

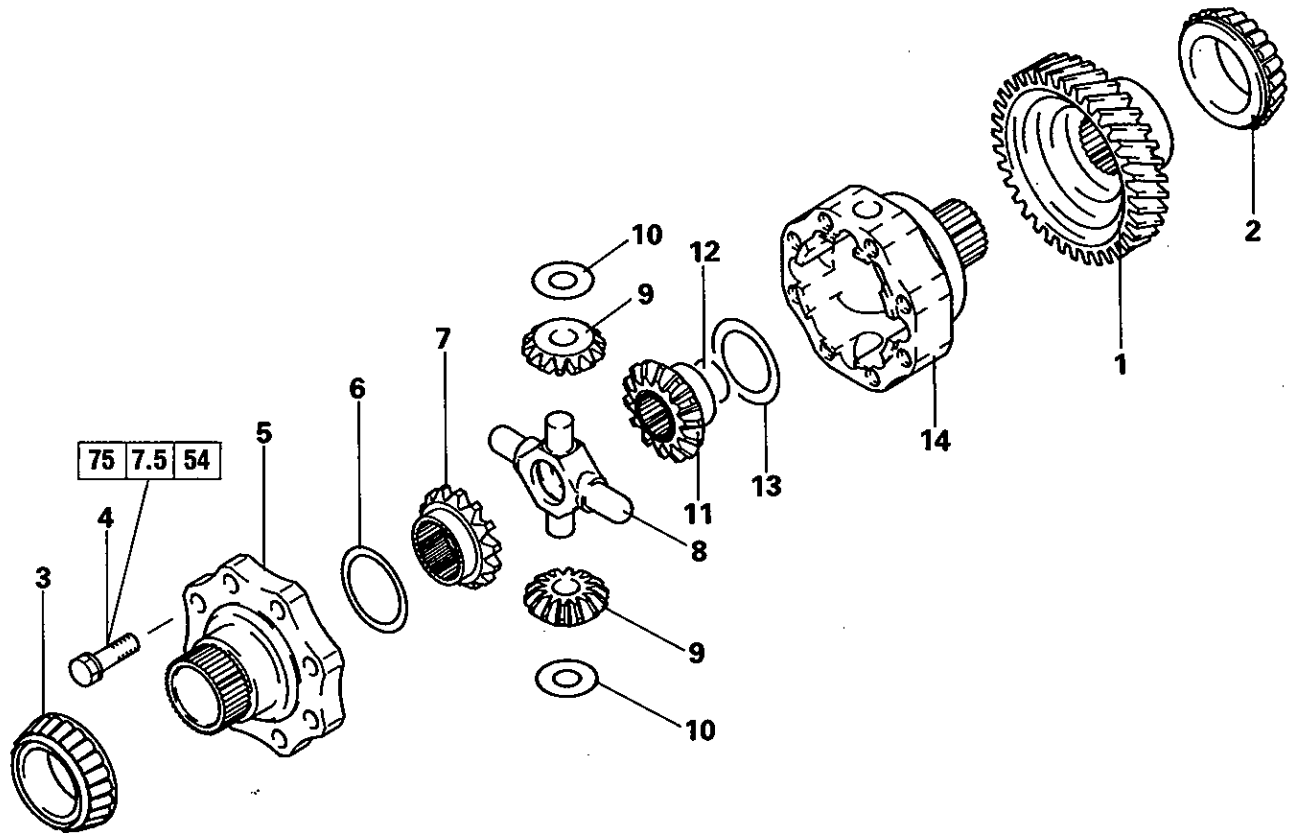

Disassembly steps

- ◊A◊ 1. Transfer driven gear
- ◊B◊ ◊D◊ 2. Taper roller bearing
- ◊C◊ ◊C◊ 3. Taper roller bearing
- ◊B◊ 4. Bolt
- 5. Center differential flange
- ◊A◊ 6. Spacer
- 7. Side gear (front)
- 8. Pinion shaft
- 9. Pinion
- 10. Washer
- 11. Side gear (rear)
- 12. Clip
- ◊A◊ 13. Spacer
- 14. Center differential case

TFA0261

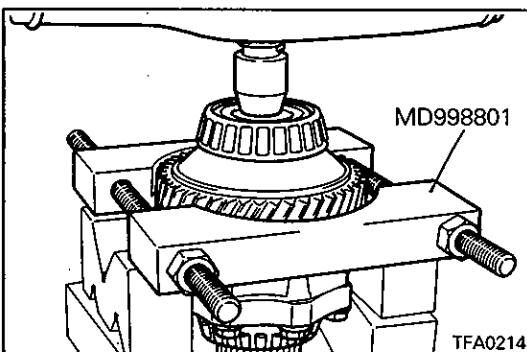

SERVICE POINTS OF DISASSEMBLY

◊A◊ REMOVAL OF TRANSFER DRIVEN GEAR

- (1) Remove the transfer driven gear.

NOTE

If it is hard to remove the gear, use the special tool.

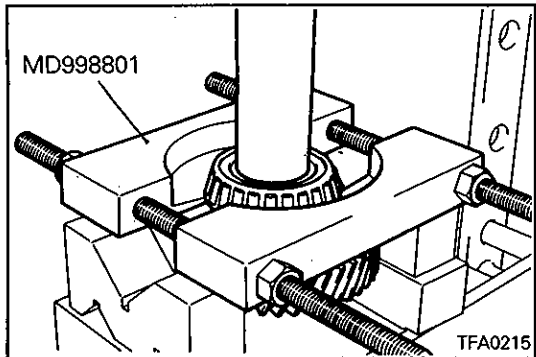

◁B▷ REMOVAL OF TAPER ROLLER BEARING

- (1) Using the special tool, remove the taper roller bearing from the transfer driven gear.

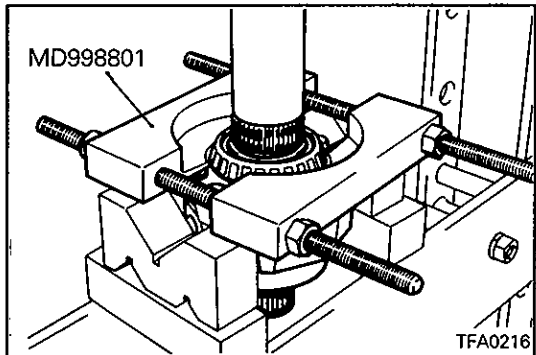

◁C▷ REMOVAL OF TAPER ROLLER BEARING

- (1) Using the special tool, remove the taper roller bearing from the center differential flange.

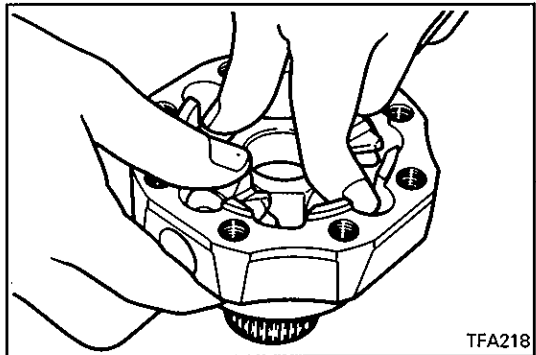

SERVICE POINTS OF REASSEMBLY

▷A◁ SELECTION OF SPACERS

- (1) Install the spacer, side rear gear, pinion, washer and pinion shaft in the center differential case.
- (2) While pressing the pinion shaft, select the thickest spacer that allows smooth rotation of the pinion.

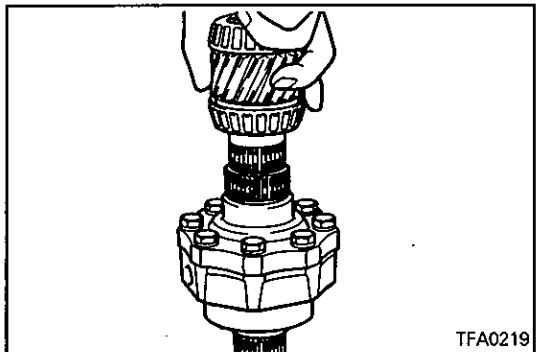

- (3) Install the front side gear, spacer and center differential flange and tighten the bolts to the specified torque.

**Center differential drive gear bolt:
75 Nm (7.5 kgm, 54 ft.lbs.)**

- (4) Using the front output shaft, rotate the front side gear and select the thickest spacer that allows smooth rotation of the front side gear.

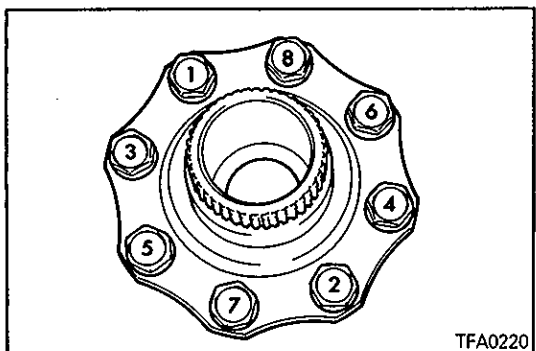

▷B◁ INSTALLATION OF BOLTS

- (1) First apply sealant to the end [5 mm (0.2 in.)] of the bolt threads and then tighten to the specified torque in the order shown in the figure.

**Center differential drive gear bolt:
75 Nm (7.5 kgm, 54 ft.lbs.)**

Specified adhesive:

3M STUD Locking Part No. 4170 or equivalent

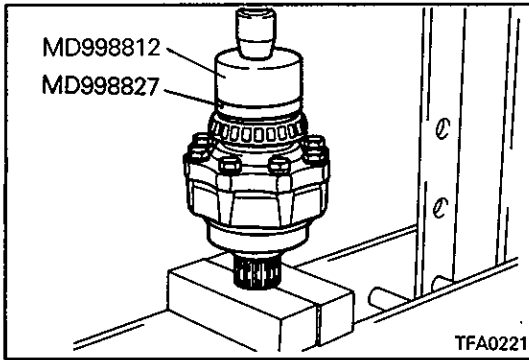

◆C◆ INSTALLATION OF TAPER ROLLER BEARING

- (1) Using the special tool, install the taper roller bearing on the center differential flange.

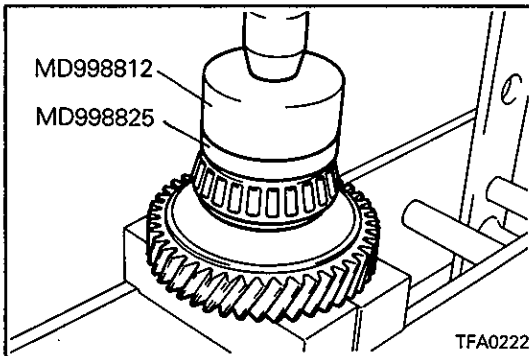

◆D◆ INSTALLATION OF TAPER ROLLER BEARING

- (1) Using the special tool, install the taper roller bearing on the transfer driven gear.

NOTES

18. FRONT OUTPUT SHAFT (W4A32, W4A33)

DISASSEMBLY AND REASSEMBLY

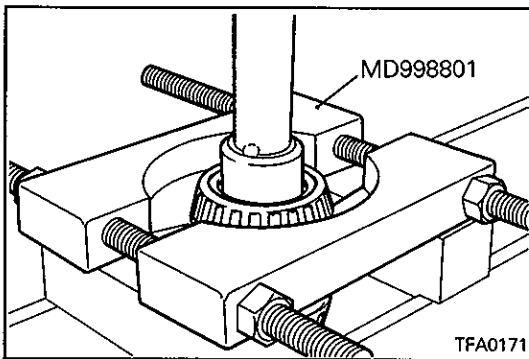
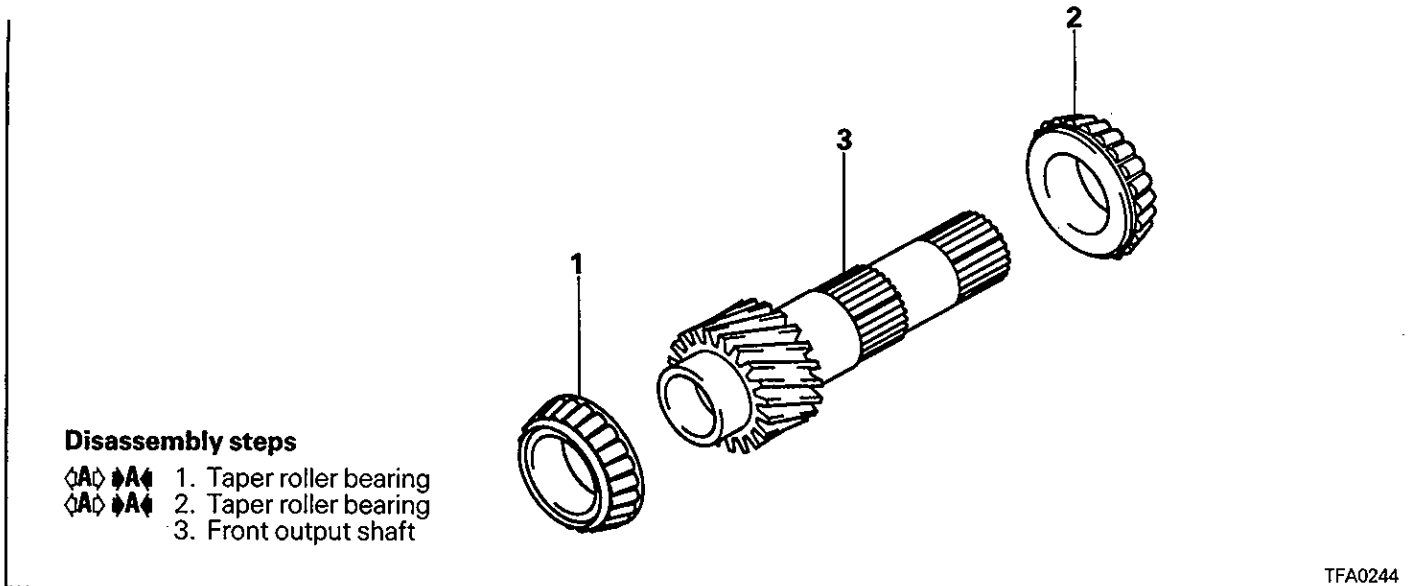

SERVICE POINT OF DISASSEMBLY

◊A◊ REMOVAL OF TAPER ROLLER BEARINGS

- (1) Using the special tool, remove the taper roller bearings on both ends of the front output shaft.

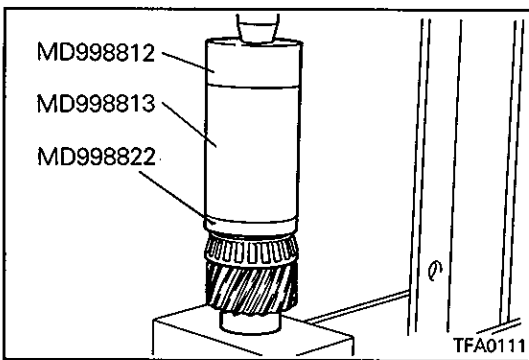

SERVICE POINT OF REASSEMBLY

◊A◊ INSTALLATION OF TAPER ROLLER BEARINGS

- (1) Using the special tool, press-fit the taper roller bearings on both ends of the front output shaft.

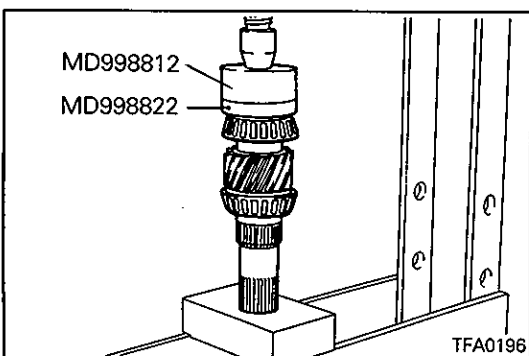

NOTES

19. TRANSFER (W4A32, W4A33)

DISASSEMBLY AND REASSEMBLY

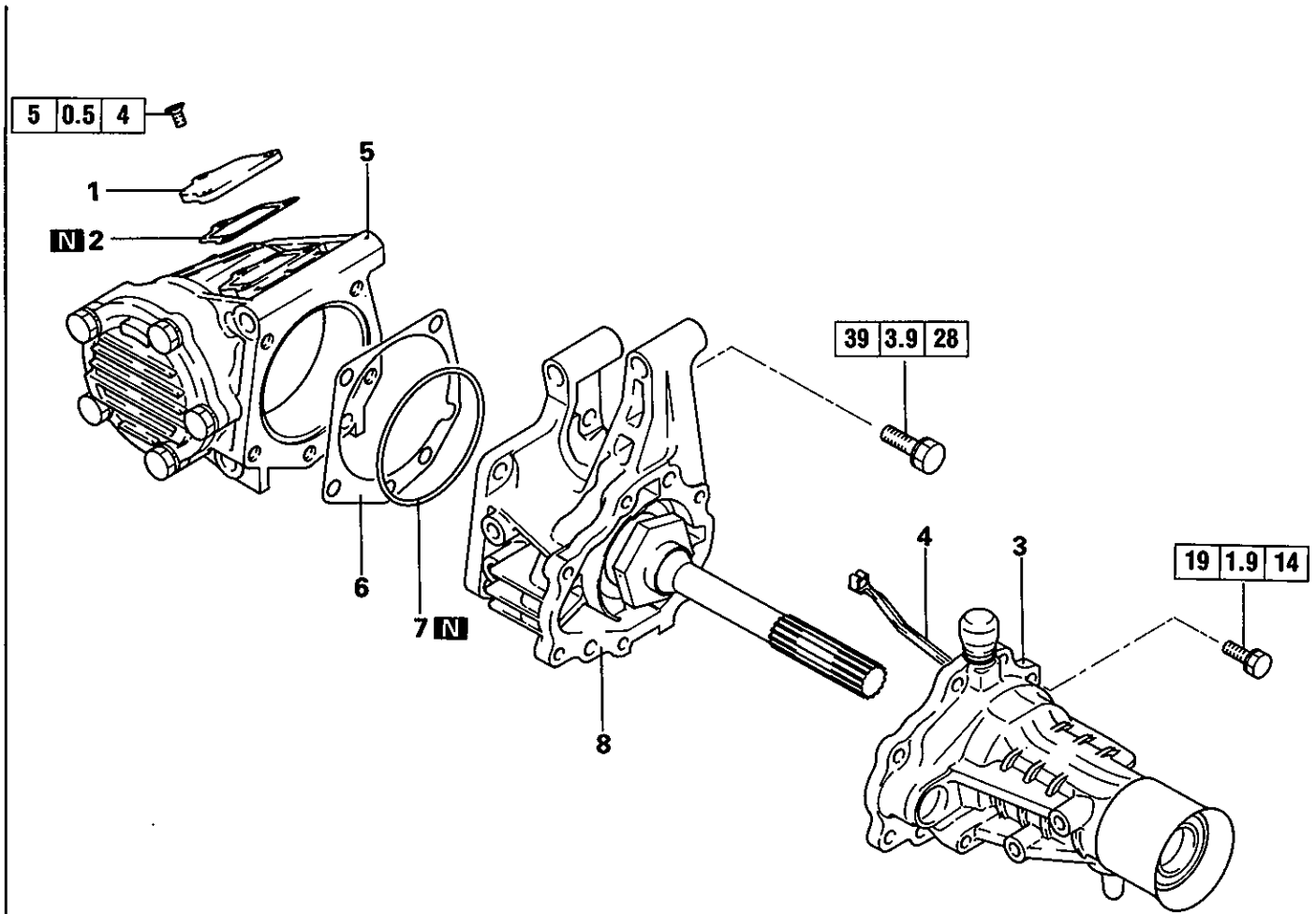

Disassembly steps

- 1. Cover
- ◆E◆ 2. Cover gasket
- ◆D◆ 3. Extension housing assembly
- 4. Oil guide
- ◆C◆ 5. Transfer case sub assembly
- ◆B◆ 6. Spacer
- 7. O-ring
- ◆A◆ 8. Transfer case adapter sub assembly

TFA0601

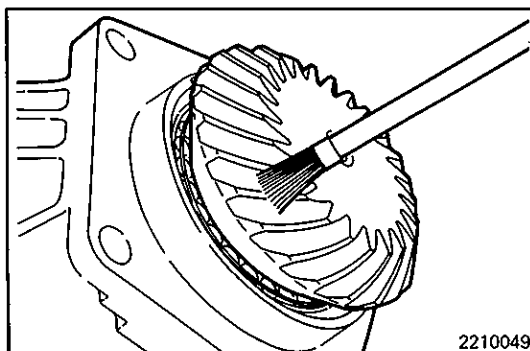

2210049

SERVICE POINTS OF REASSEMBLY

◆A◆ INSTALLATION OF TRANSFER CASE ADAPTER SUB ASSEMBLY

- (1) Apply a light and uniform coat of machine blue or red lead to the driven bevel gear teeth (both sides) using a brush so that the tooth contact pattern can be checked later.

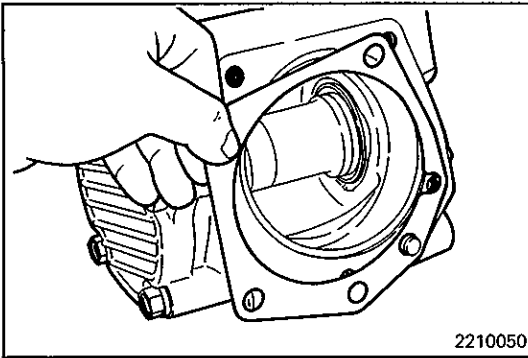

▶B▶ INSTALLATION OF SPACER

- (1) Install the same spacer that has been removed during disassembly.

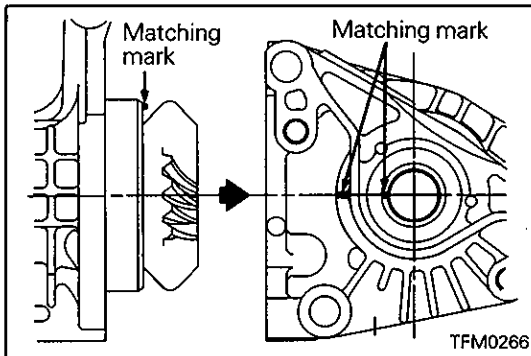

▶C▶ INSTALLATION OF TRANSFER CASE SUB ASSEMBLY

- (1) With the matching marks in alignment, install the transfer case adapter sub assembly to the transfer case sub assembly.

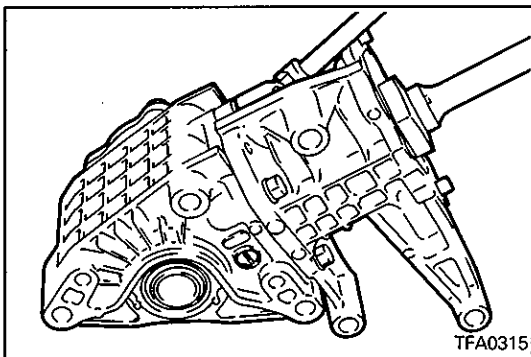

- (2) Tighten the transfer case adapter sub assembly to transfer case sub assembly mounting bolts to the specified torque.

**Transfer case adapter mounting bolt:
39 Nm (3.9 kgm, 28 ft.lbs.)**

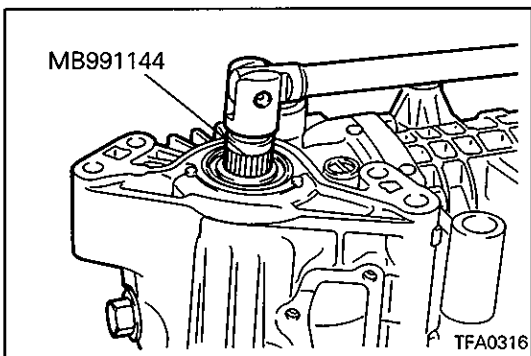

- (3) Using the special tool, turn the drive bevel gear shaft (one turn in normal direction, one turn in reverse direction) in order to obtain the tooth contact pattern.

NOTE

Do not give the drive bevel gear shaft more than one turn in either direction as this causes unclear tooth contact pattern.

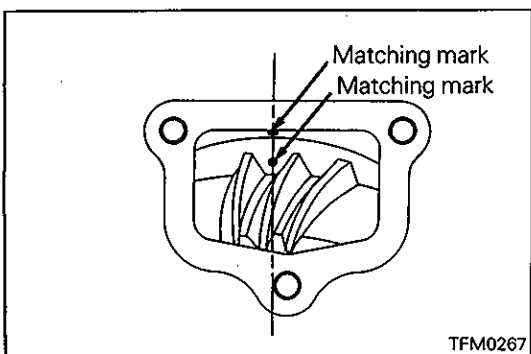

- (4) Make sure that the driven bevel gear and transfer case matching marks are in alignment.

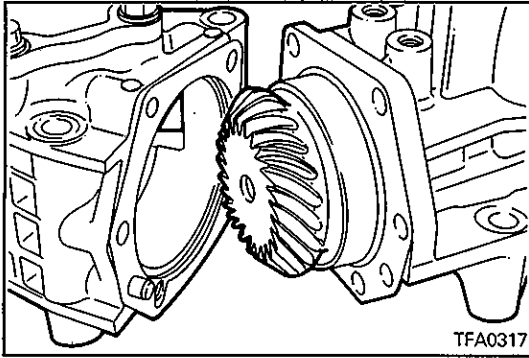

- (5) Check to see if the drive bevel gear tooth contact is normal.

NOTE

Refer to the TOOTH CONTACT ADJUSTMENT PROCEDURES on the next page for the standard tooth contact pattern.

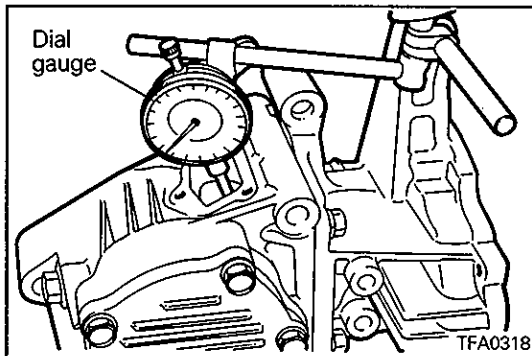

- (6) Check the backlash between the drive and driven bevel gears.

Standard value: Bevel gear set backlash
0.08 – 0.13 (0.0031 – 0.0051 in.)

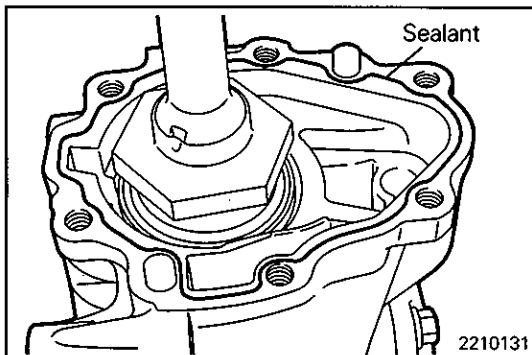

◆D◆ INSTALLATION OF EXTENSION HOUSING

- (1) Apply sealant to the adapter flange surface and install the extension housing.

Specified sealant:

Mitsubishi genuine sealant Part No. MD997740 or equivalent

NOTE

Squeeze out sealant from the tube uniformly and continuously in adequate amount.

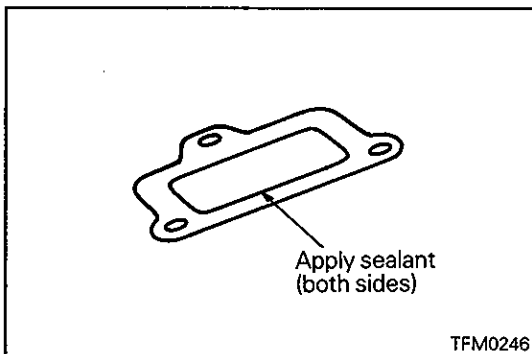

◆E◆ APPLICATION OF SEALANT TO COVER GASKET

Specified sealant:

3M ATD Part No. 8660 or equivalent

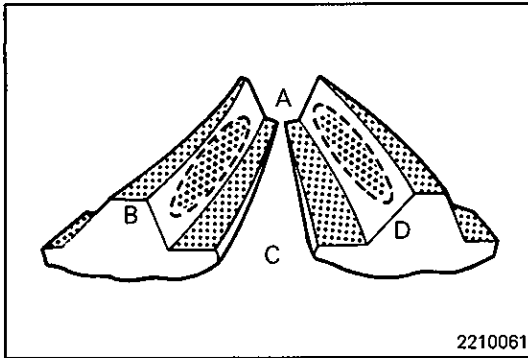

TOOTH CONTACT ADJUSTING PROCEDURES

1. Standard tooth contact pattern

- A Toe end
- B Drive side tooth face
(Side on which force acts when running forward)
- C Heel end
- D Coast side tooth face
(Side on which force acts when reversing)

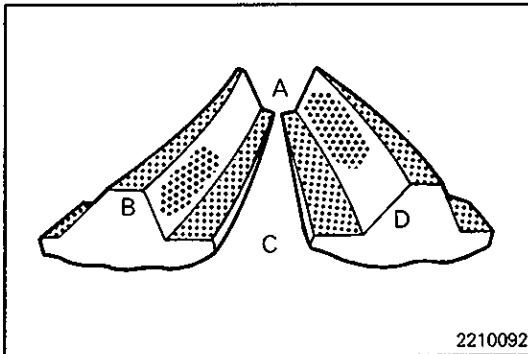

2. Tooth contact pattern produced when drive bevel gear height is too large

Cause

The driven bevel is too close to the drive bevel gear.

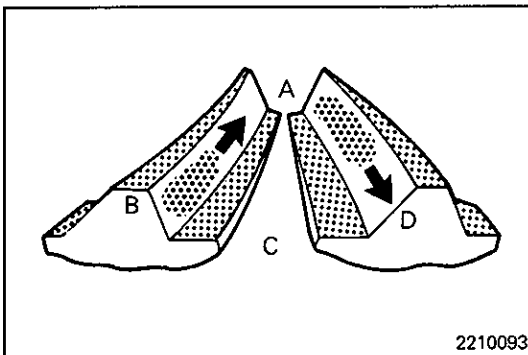

Remedy

Use thicker bevel gear mount adjusting spacer to separate the driven bevel gear more from the drive bevel gear.

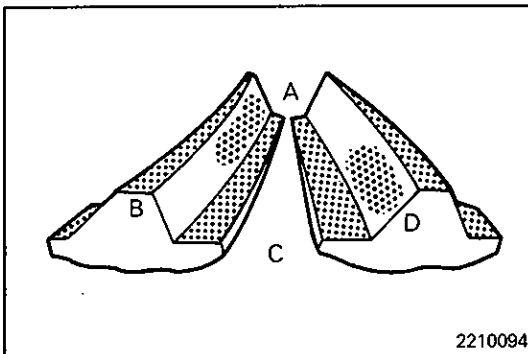

3. Tooth contact pattern produced when driven bevel gear height is too small

Cause

The driven bevel gear is too separated from the drive bevel gear.

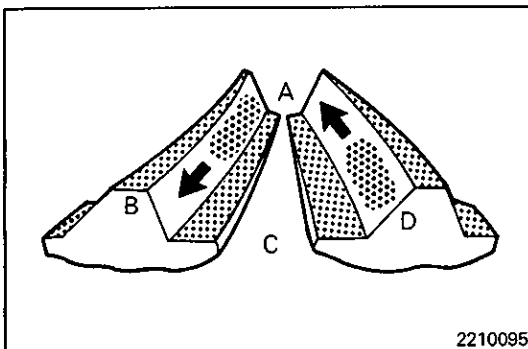

Remedy

Use thinner driven bevel gear mount adjusting spacer to bring the driven bevel gear closer to the drive bevel gear.

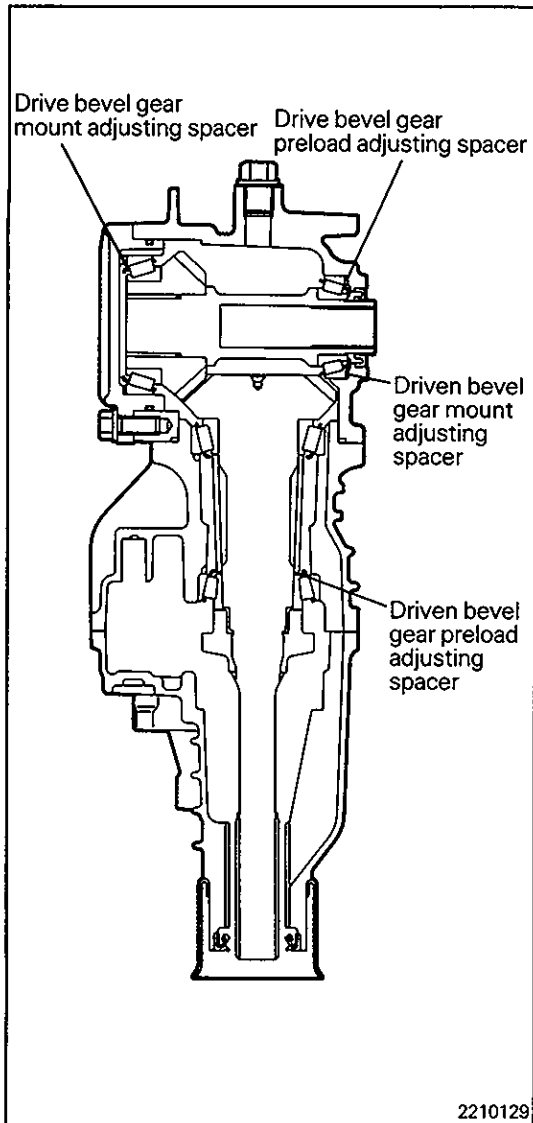

NOTE

- (1) If correct tooth contact cannot be obtained even by changing the driven bevel gear mount adjusting spacer, install thicker or thinner drive bevel gear preload adjusting spacer and drive bevel gear mount adjusting spacer as described below, and then adjust the tooth contact again.
- When the driven bevel gear height is too small even if the thinnest driven bevel gear mount adjusting spacer [0.13 mm (0.0051 in.)] is used:
Replace the originally installed drive bevel gear mount adjusting spacer with one rank thicker one and the drive bevel gear preload adjusting spacer with a next thinner one.
 - When the driven bevel gear height is too large even if the thickest driven bevel gear mount adjusting spacer [0.52 mm (0.025 in.)] is used:
Replace the originally installed drive bevel gear mount adjusting spacer with one rank thinner one and the drive bevel gear preload adjusting spacer with a next thicker one.
Repeat above steps until the tooth contact pattern equal or close to the standard pattern is obtained.
- (2) If correct tooth contact pattern cannot be obtained by the above adjustments, replace both the drive and driven bevel gears as a set and readjust the tooth contact.

NOTES

20. TRANSFER CASE ADAPTER (W4A32, W4A33)

DISASSEMBLY AND REASSEMBLY

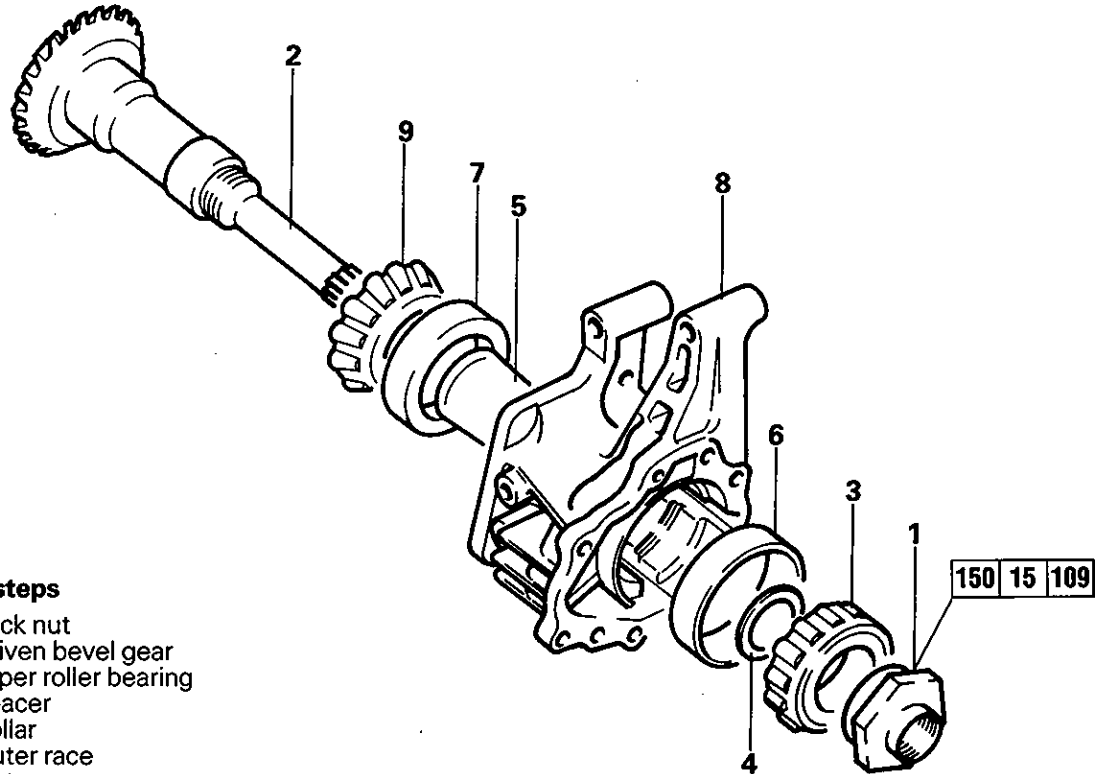

Disassembly steps

- ◇A◇ ▶B◇ 1. Lock nut
- ◇B◇ ▶D◇ 2. Driven bevel gear
- ▶C◇ 3. Taper roller bearing
- ▶B◇ 4. Spacer
- 5. Collar
- ◇C◇ 6. Outer race
- ◇C◇ 7. Outer race
- 8. Transfer case adapter
- ◇D◇ ▶A◇ 9. Taper roller bearing

TEA0604

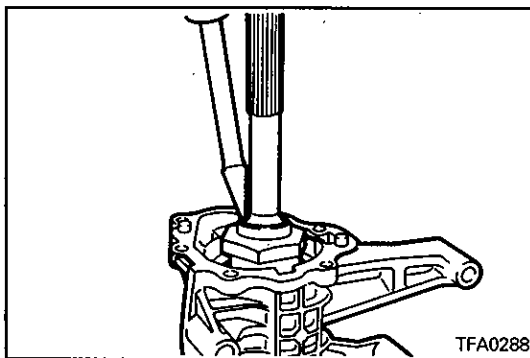

SERVICE POINTS OF DISASSEMBLY

◇A◇ REMOVAL OF LOCK NUT

(1) Unlock the lock nut. (Undo the staking.)

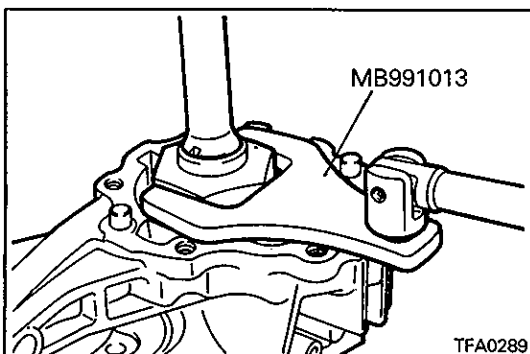

(2) Holding the driven bevel gear in a vice and using the special tool, remove the lock nut.

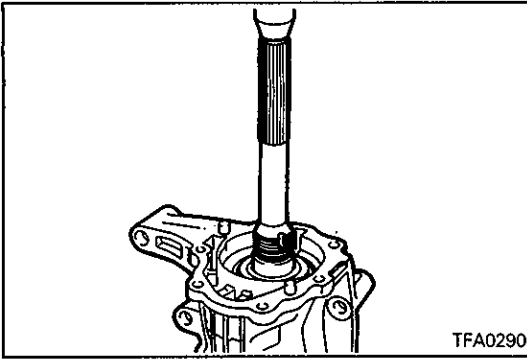

- ◁B▷ **REMOVAL OF DRIVEN BEVEL GEAR ASSEMBLY**
 (1) Use a press to remove the driven bevel gear assembly.

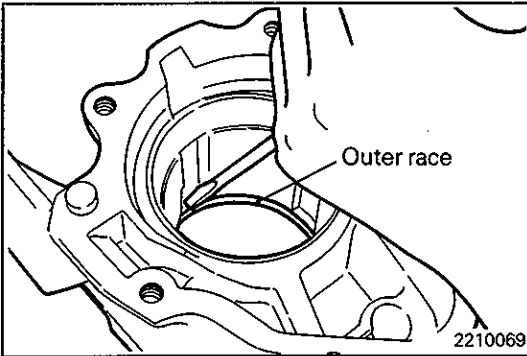

- ◁C▷ **REMOVAL OF OUTER RACE**
 (1) Remove the outer race, striking lightly with a screwdriver, etc.

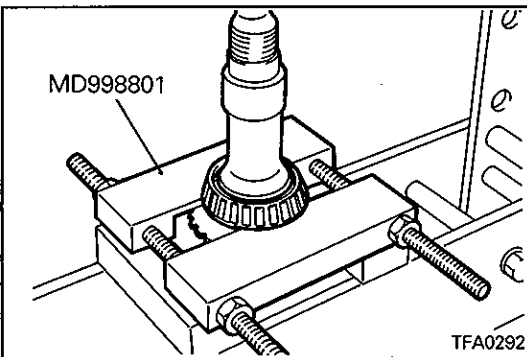

- ◁D▷ **REMOVAL OF TAPER ROLLER BEARING**

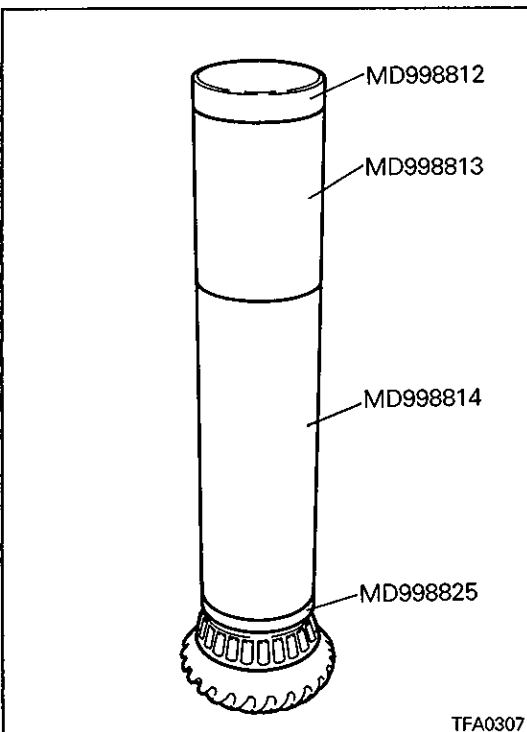

SERVICE POINTS OF REASSEMBLY

- ▷A▷ **INSTALLATION OF TAPER ROLLER BEARING**

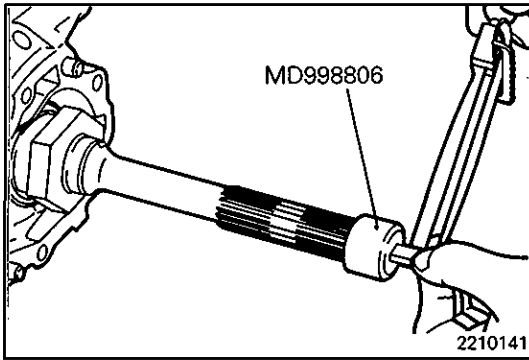

▶B▶ SELECTION OF SPACER

- (1) Use the originally installed spacer to assemble the transfer case adapter.
- (2) Using the special tool, check that the bevel gear rotating drive torque is within standard range.

Standard value: 1.4 Nm (0.14 kgm, 1.0 ft.lbs.)

- (3) If the rotating drive torque is not within the standard range, adjust using adjusting spacers.

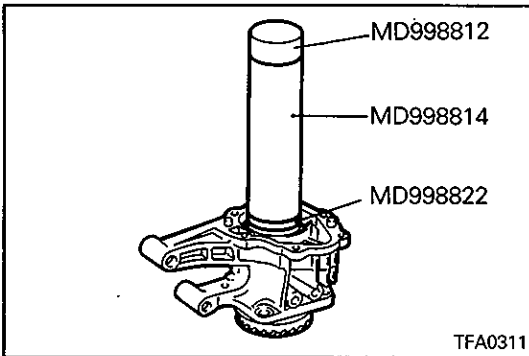

▶C▶ INSTALLATION OF TAPER ROLLER BEARING

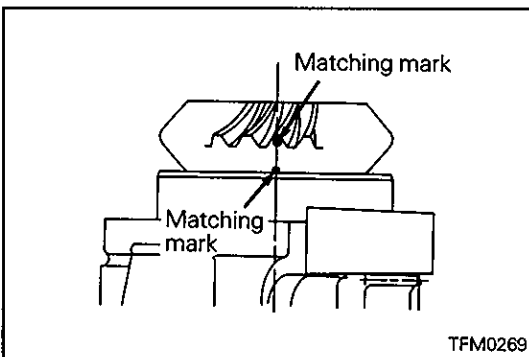

▶D▶ INSTALLATION OF DRIVEN BEVEL GEAR

- (1) Assemble the driven bevel gear in the transfer case adapter and then align their matching marks.

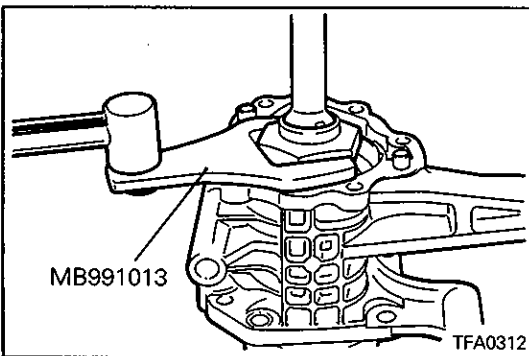

▶E▶ INSTALLATION OF LOCK NUT

- (1) Holding the driven bevel gear in a vice and using the special tool, tighten the lock nut to the specified torque.

Driven bevel gear lock nut: 150 Nm (15 kgm, 108 ft.lbs.)

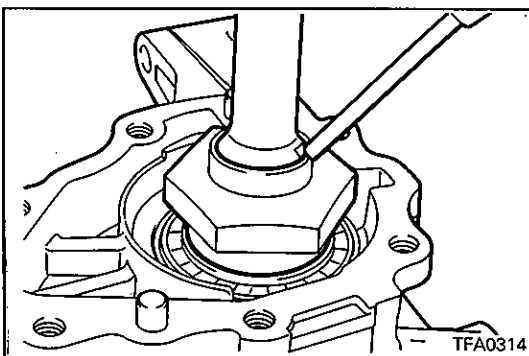

- (2) Stake the lock nut at two places.

NOTES

21. TRANSFER CASE (W4A32, W4A33)

DISASSEMBLY AND REASSEMBLY

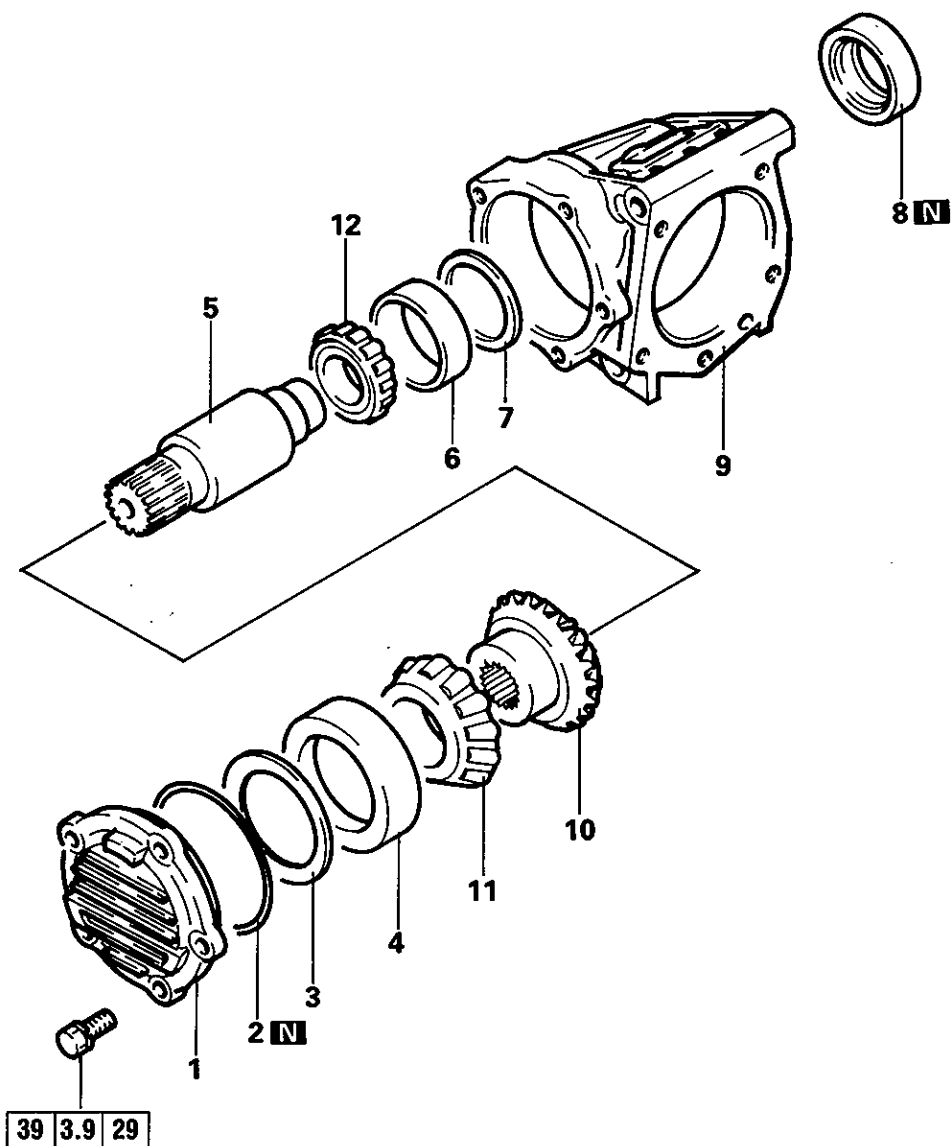

Disassembly steps

1. Transfer cover
2. O-ring
- ◆E◆ 3. Spacer
- ◆D◆ 4. Outer race
- ◆D◆ 5. Drive bevel gear shaft
6. Outer race
- ◆E◆ 7. Spacer
- ◆C◆ 8. Oil seal
9. Transfer case
- ◆B◆ 10. Drive bevel gear
- ◇A◇ ◆A◆ 11. Taper roller bearing
- ◇A◇ ◆A◆ 12. Taper roller bearing

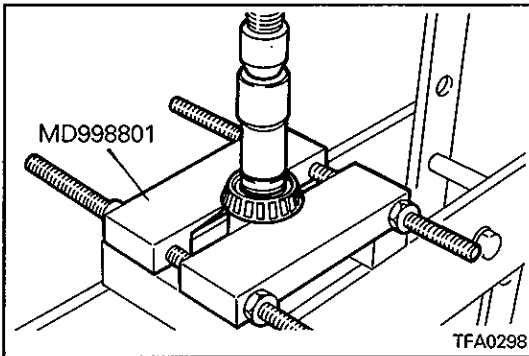
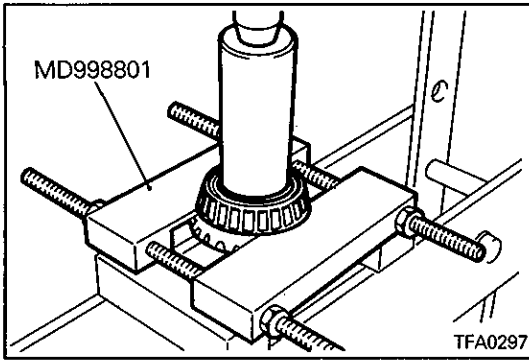
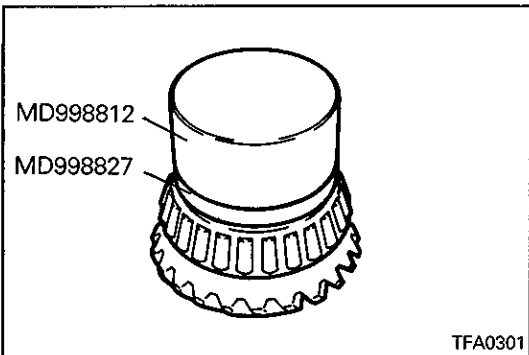
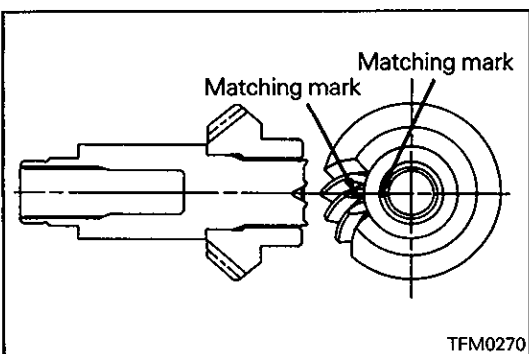
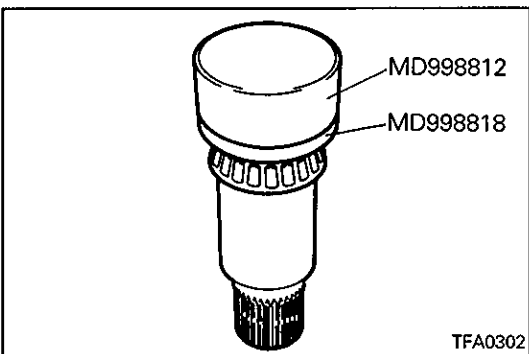
**SERVICE POINT OF DISASSEMBLY****◁A▷ REMOVAL OF TAPER ROLLER BEARINGS****SERVICE POINTS OF REASSEMBLY****▶A▶ INSTALLATION OF TAPER ROLLER BEARING****▶B▶ INSTALLATION OF DRIVE BEVEL GEAR**

- (1) Install the drive bevel gear on the drive bevel gear shaft with their matching marks in alignment.

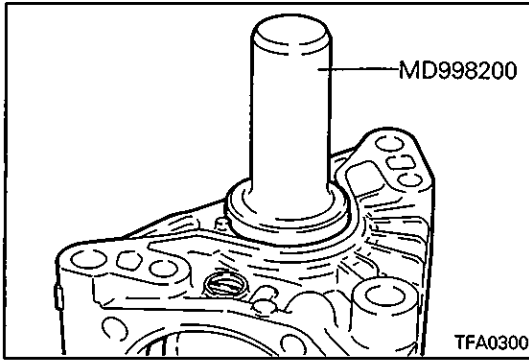

◆C◆ INSTALLATION OF OIL SEAL

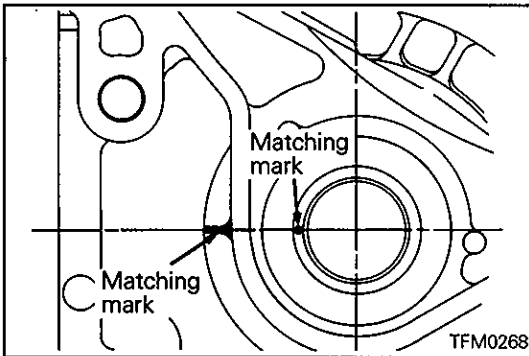

◆D◆ INSTALLATION OF DRIVE BEVEL GEAR SHAFT

- (1) Install the drive bevel gear shaft in the transfer case and align the matching mark on the transfer case with that on the drive bevel gear shaft.

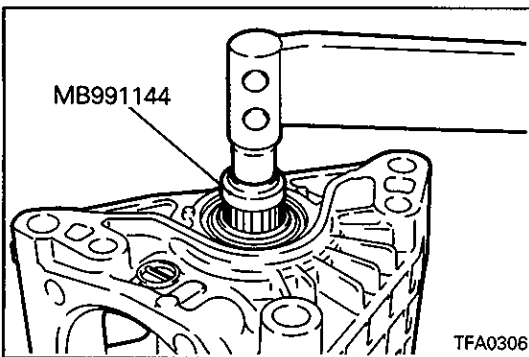

◆E◆ SELECTION OF SPACER

- (1) Use the originally installed spacer to assemble the transfer case.
- (2) Using the special tool, check that the bevel gear rotating drive torque is within the standard range.
Standard value: 2.2 Nm (0.22 kgm, 1.6 ft.lbs.)
- (3) If the rotating drive torque is not within the standard range, adjust using adjusting spacers.

NOTE

For adjustment, use two spacers whose thickness is as close as possible to each other.

NOTES

22. EXTENSION HOUSING (W4A32, W4A33)

DISASSEMBLY AND REASSEMBLY

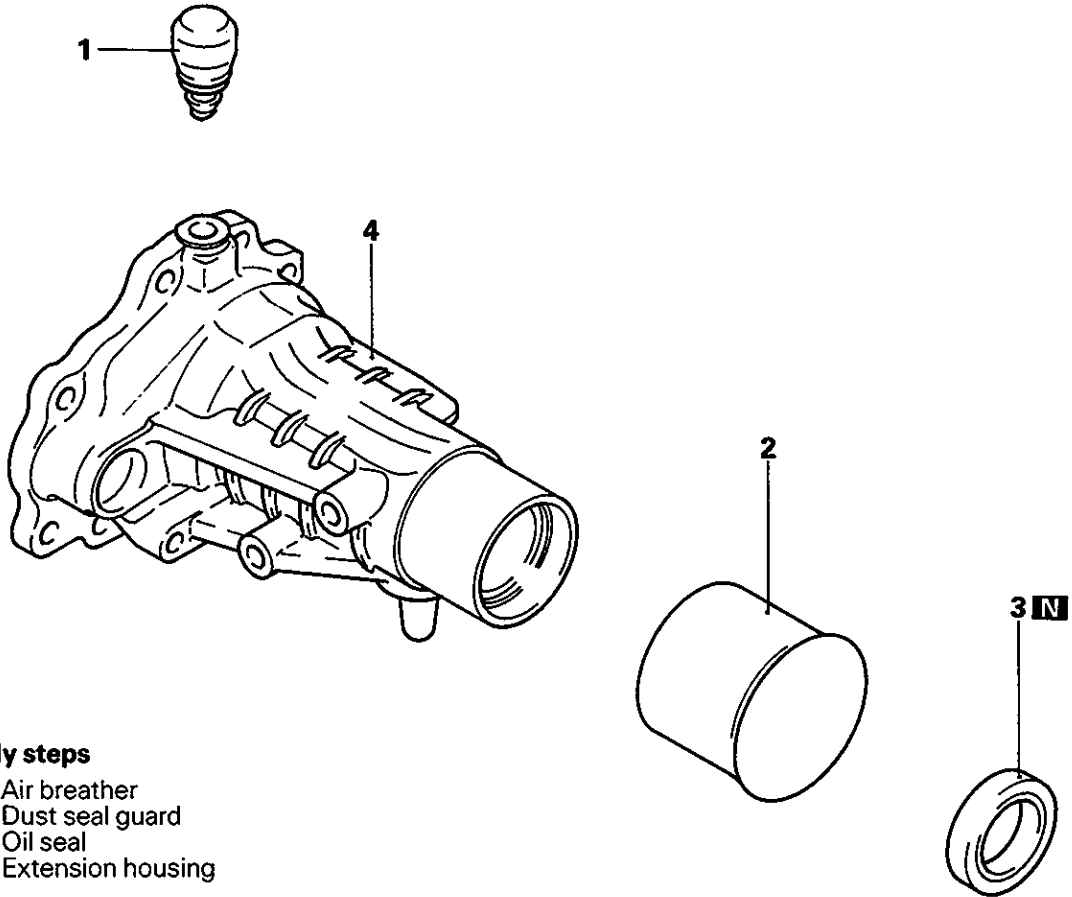

Disassembly steps

- ▶B▶ 1. Air breather
- ▶A▶ 2. Dust seal guard
- ▶A▶ 3. Oil seal
- ▶A▶ 4. Extension housing

TFA0602

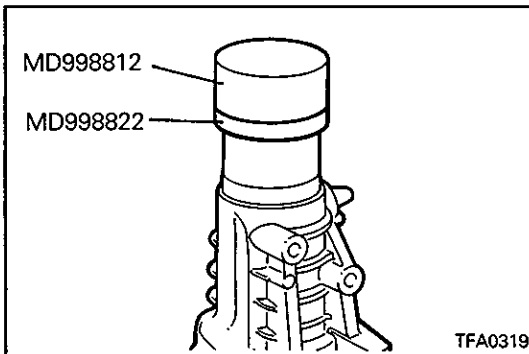

SERVICE POINTS OF REASSEMBLY

▶A▶ INSTALLATION OF OIL SEAL

▶B▶ INSTALLATION OF AIR BLEEDER

- (1) Install the air bleeder applying sealant to the inserting portion.

Specified sealant:

3M SUPER WETHERSTRIP No. 8001 or equivalent

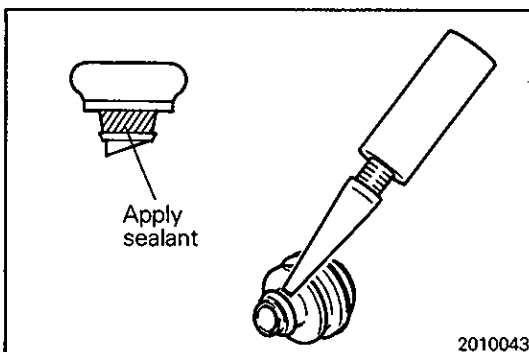

2010043

NOTES

23. 4-WHEEL STEERING OIL PUMP DRIVE GEAR

DISASSEMBLY AND REASSEMBLY

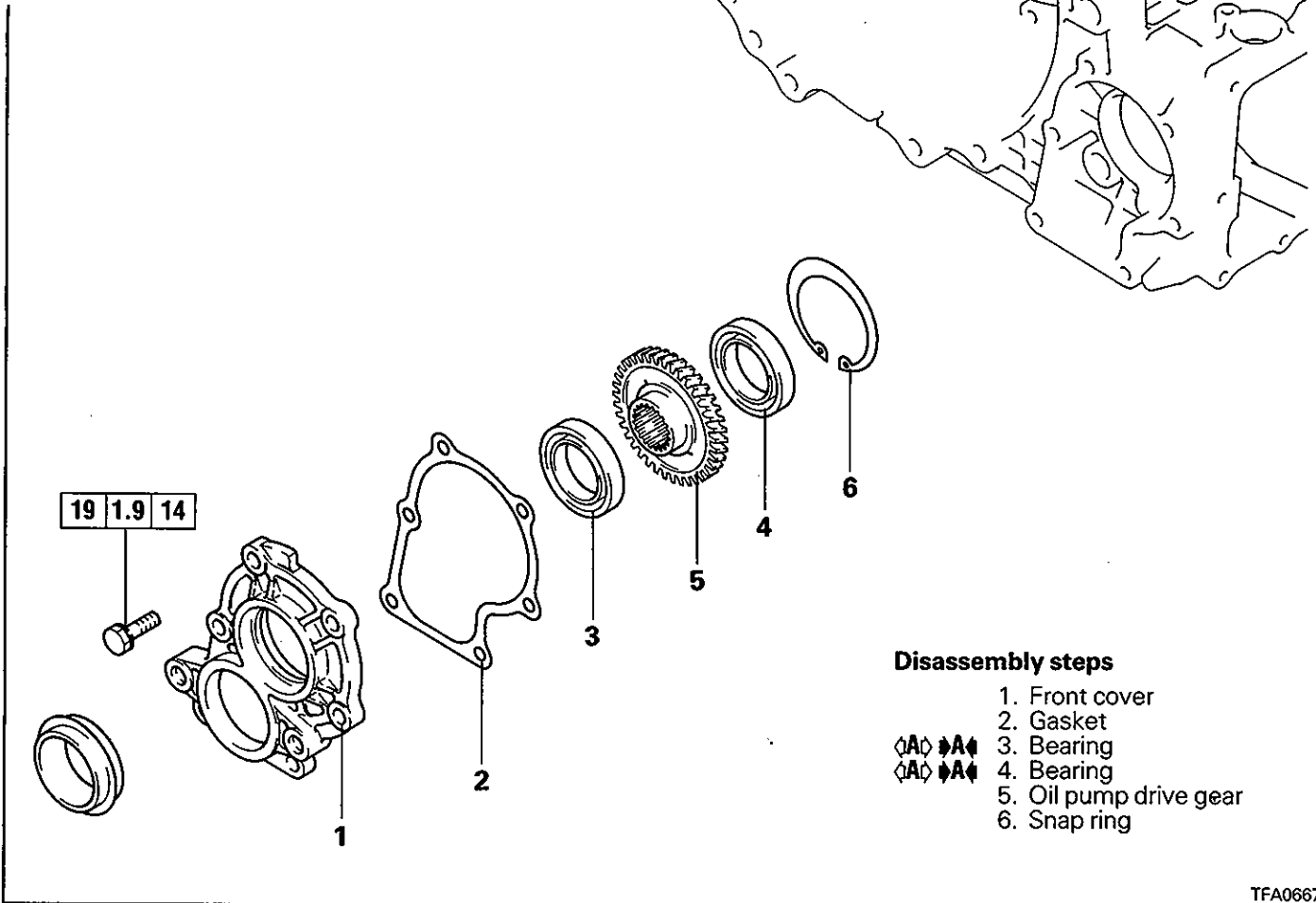

TFA0667

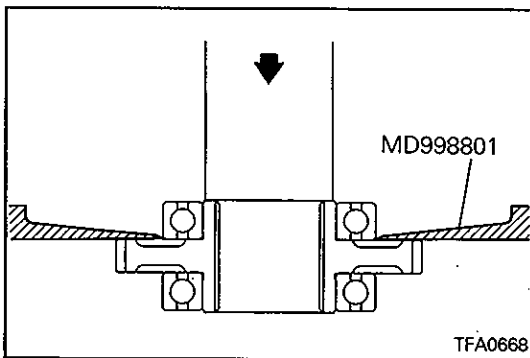

SERVICE POINT OF DISASSEMBLY

◁A▷ REMOVAL OF BEARING

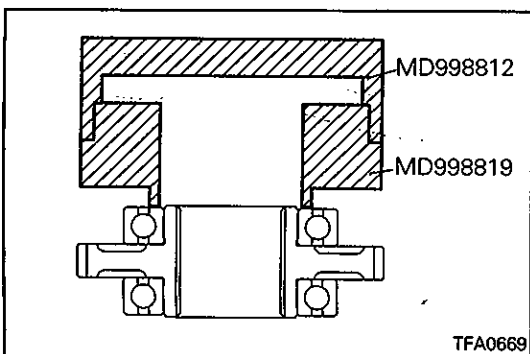

SERVICE POINT OF REASSEMBLY

▷A◁ INSTALLATION OF BEARING

NOTES