

# AUTOMATIC TRANSMISSION V4AW4

## CONTENTS

GENERAL INFORMATION .....	23C-0-3
1. SPECIFICATIONS .....	23C-1-1
TRANSMISSION MODEL TABLE <del>MODEL 1099</del> .....	23C-1-1
GENERAL SPECIFICATIONS .....	23C-1-2
SERVICE SPECIFICATIONS .....	23C-1-3
IDENTIFICATION OF SPRING .....	23C-1-4
TORQUE SPECIFICATION .....	23C-1-5
SNAP RINGS AND SPACERS FOR ADJUSTMENT .....	23C-1-6
SEALANTS .....	23C-1-7
LUBRICANT .....	23C-1-8
2. SPECIAL TOOLS .....	23C-2-1
3. TRANSMISSION .....	23C-3-1
4. OIL PUMP .....	23C-4-1
5. OVERDRIVE CLUTCH .....	23C-5-1
6. OVERDRIVE PLANETARY GEAR .....	23C-6-1
7. OVERDRIVE BRAKE .....	23C-7-1
8. DIRECT CLUTCH .....	23C-8-1
9. FORWARD CLUTCH .....	23C-9-1
10. CENTER SUPPORT .....	23C-10-1
11. FRONT PLANETARY GEAR .....	23C-11-1
12. REAR PLANETARY GEAR AND OUTPUT SHAFT .....	23C-12-1
13. No.3 BRAKE PISTON .....	23C-13-1
14. VALVE BODY .....	23C-14-1
15. FRONT UPPER VALVE BODY .....	23C-15-1
16. REAR UPPER VALVE BODY .....	23C-16-1
17. LOWER VALVE BODY .....	23C-17-1
18. TRANSFER .....	23C-18-1
19. 2WD/4WD SHIFT FORK AND RAIL .....	23C-19-1
20. 2WD/4WD SYNCHRONIZER .....	23C-20-1
21. FRONT OUTPUT SHAFT .....	23C-21-1
22. TRANSFER CASE PLATE .....	23C-22-1
23. INPUT GEAR .....	23C-23-1
24. REAR OUTPUT SHAFT .....	23C-24-1

NOTES

# STANDARD HOLE DRILLING MACHINE

1. This machine is designed for drilling holes in metal workpieces. It is suitable for drilling holes of diameter up to 10 mm and depth up to 100 mm. The machine is equipped with a hand crank for manual operation and a motor for power operation. The motor is rated at 1/2 HP and 115V AC. The machine is also equipped with a depth gauge for precise drilling. The machine is made of cast iron and is very sturdy. It is suitable for use in a workshop or laboratory. The machine is easy to use and requires little maintenance. It is a good investment for anyone who needs a reliable drilling machine.

## GENERAL INFORMATION

### TRANSMISSION

This transmission is an Aisin AW, electronically-controlled, 4-speed, automatic transmission.

- It comprises three multiple-plate clutch assemblies, four multiple-plate brake assemblies, and three planetary gear assemblies.
- Two individual speed sensors are used to detect the input speed and the output speed.
- Holding three individual solenoid valves, the valve body regulates the control oil pressure and adjusts shaft timing.

### SECTION VIEW

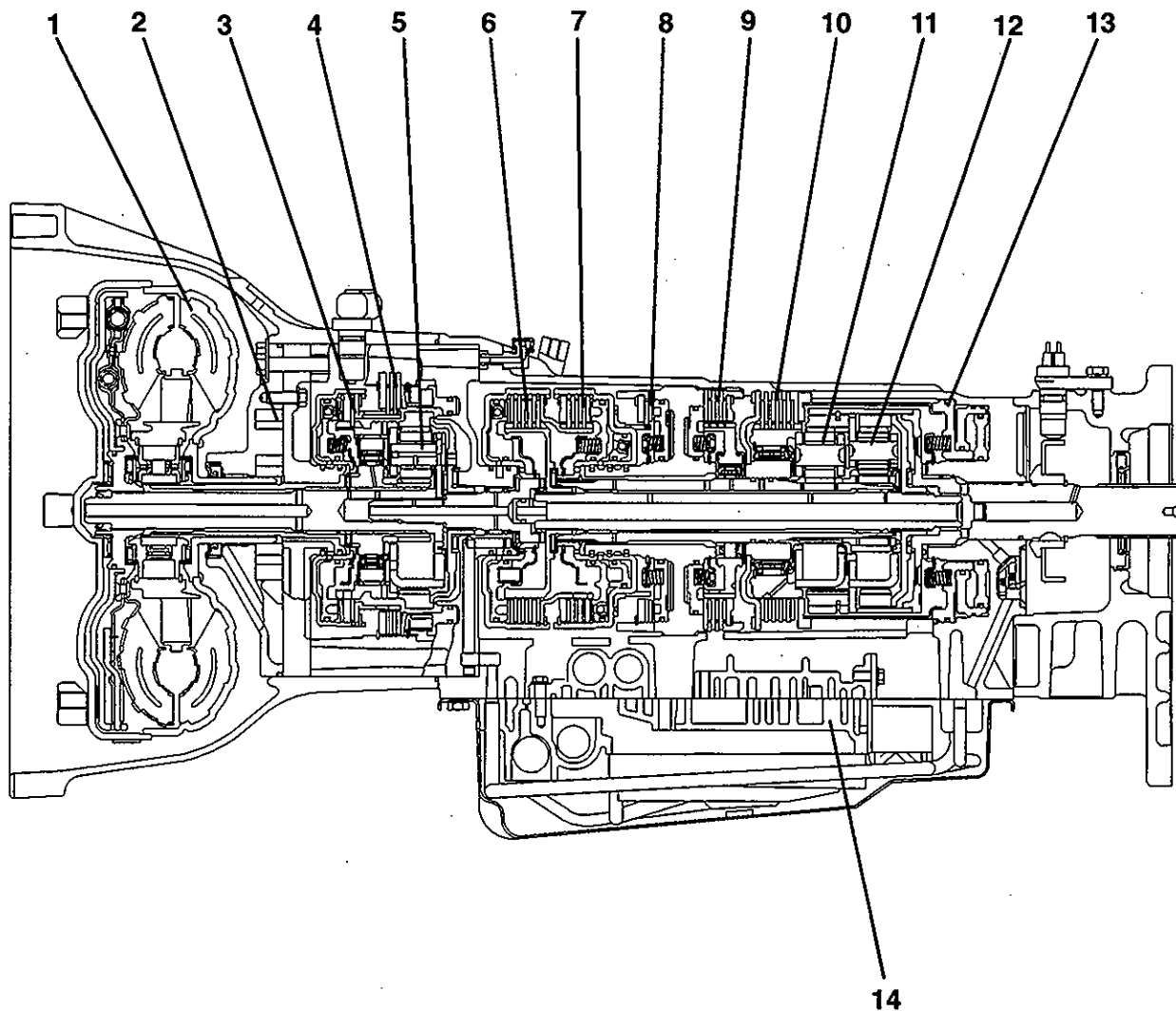

1. Torque converter
2. Oil pump
3. Overdrive clutch
4. Overdrive brake
5. Overdrive planetary gear
6. Forward clutch
7. Direct clutch

8. No.1 brake
9. No.2 brake
10. No.3 brake
11. Front planetary gear
12. Rear planetary gear
13. No.3 brake piston
14. Valve body

TRA1573

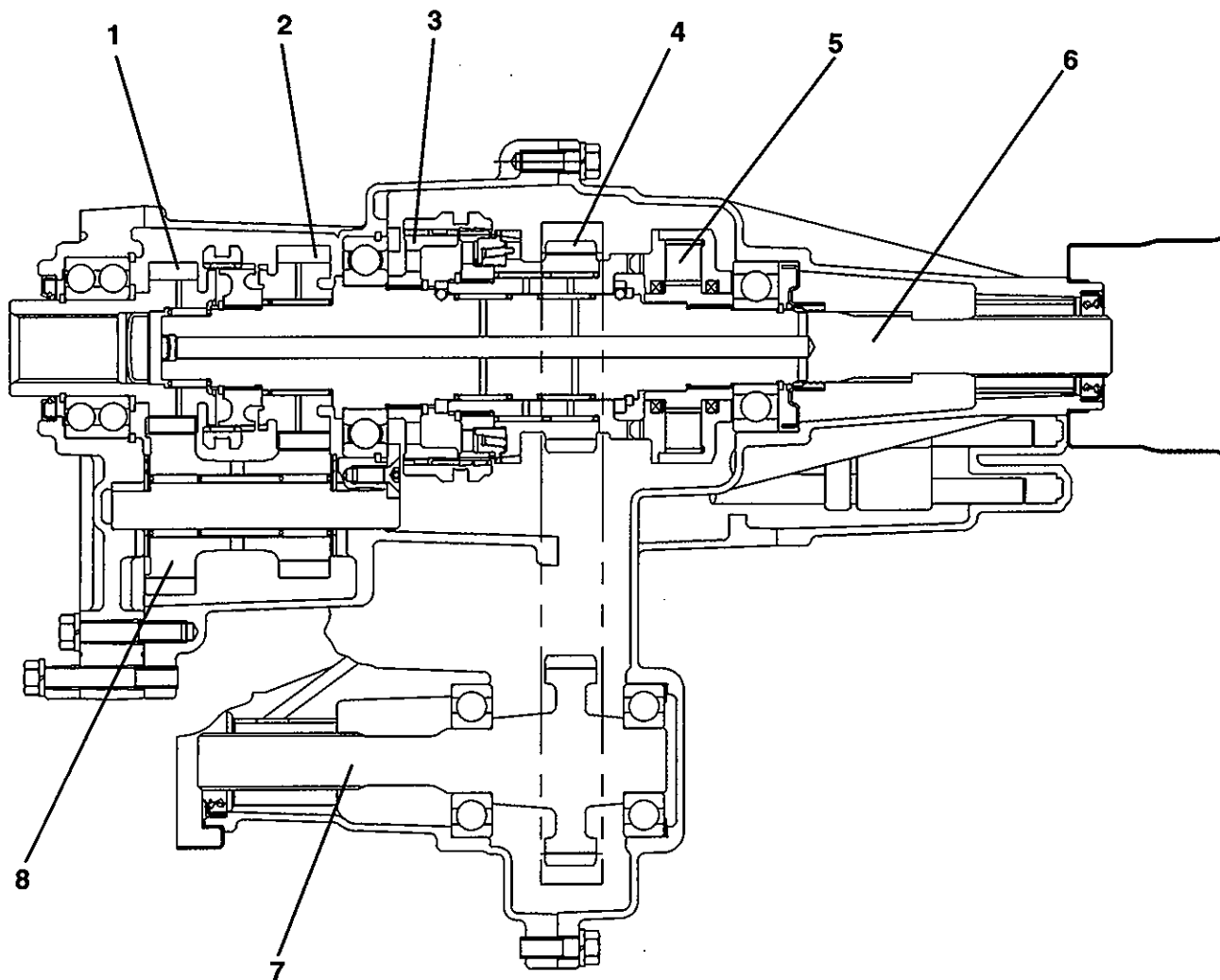
**TRANSFER  
SECTION VIEW**

TRA1762

1. Input gear
2. Low-speed gear
3. Differential lock hub
4. 2WD/4WD synchronizer
5. Viscous coupling
6. Rear output shaft
7. Front output shaft
8. Counter shaft

## HYDRAULIC CIRCUIT DIAGRAM

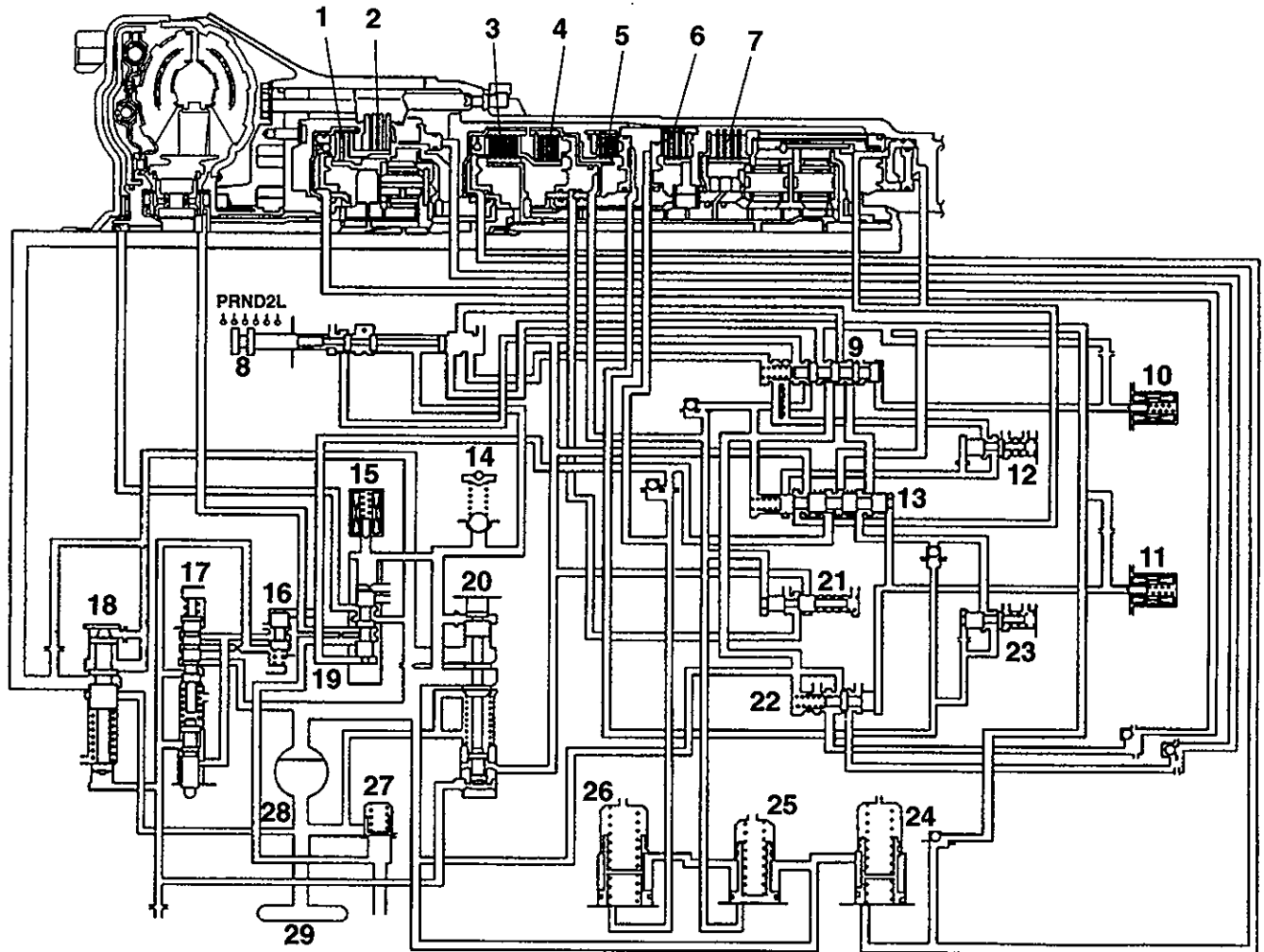

AW0179AG

- |                               |                                   |
|-------------------------------|-----------------------------------|
| 1. Overdrive clutch           | 16. Cutback valve                 |
| 2. Overdrive brake            | 17. Throttle valve                |
| 3. Forward clutch             | 18. Secondary regulator valve     |
| 4. Direct clutch              | 19. Lockup control valve          |
| 5. No.1 brake                 | 20. Primary regulator valve       |
| 6. No.2 brake                 | 21. Reverse clutch sequence valve |
| 7. No.3 brake                 | 22. 3-4 shift valve               |
| 8. Manual valve               | 23. Intermediate modulator valve  |
| 9. 2-3 shift valve            | 24. C1 accumulator                |
| 10. Solenoid valve No.1       | 25. C2 accumulator                |
| 11. Solenoid valve No.2       | 26. B2 accumulator                |
| 12. Low coast modulator valve | 27. Oil cooler bypass valve       |
| 13. 1-2 shift valve           | 28. Oil pump                      |
| 14. Pressure relief valve     | 29. Strainer                      |
| 15. Solenoid valve No.3       |                                   |

---

**NOTES**

# 1. SPECIFICATIONS

## TRANSMISSION MODEL TABLE - MODEL 1999

Transmission models		Vehicle model	Engine model
EUR	V4AW4-D-AG	H66W	4G93-GDI
	V4AW4-D-AH	H66W	4G93-GDI
EXP	V4AW4-D-CJ	H65W	4G18-SOHC
	V4AW4-D-AG	H66W, H76W	4G93-GDI
	V4AW4-D-BH	H76W	4G93-SOHC
MMAL	V4AW4-D-BH	H76W	4G93-SOHC

## TRANSMISSION MODEL TABLE - MODEL 2001

Transmission models		Vehicle model	Engine model
EUR	V4AW4-D-D1	H67W, H77W	4G94-GDI
EXP	V4AW4-D-CJ	H65W	4G18-SOHC
	V4AW4-D-AG	H66W, H76W	4G93-GDI
	V4AW4-D-BH	H76W	4G93-SOHC
MMAL	V4AW4-D-BH	H76W	4G93-SOHC

## GENERAL SPECIFICATIONS

Item		V4AW4	
Torque convertor	Type	3-element, 1-stage, 2-phase type with lockup clutch	
Transmission	Type	4-speed, fully automatic	
	Gear ratios	1st gear	2.826
		2nd gear	1.493
		3rd gear	1.000
		4th gear	0.730
		Reverse	2.703
	Number of overdrive clutch discs		1
	Number of overdrive brake discs		2
	Number of forward clutch discs		4
	Number of direct clutch discs		3
	Number of No.1 brake discs		1
Number of No.2 brake discs		3	
Number of No.3 brake discs		5	
Transfer	Type	2-speed full-time transfer with differential lock	
	Gear ratios	High	1.000
		Low	1.548



**SERVICE SPECIFICATIONS****TRANSMISSION**

Item		Standard value	Limit value
Oil pump	Side clearance mm	0.02 – 0.05	0.1
	Body clearance mm	0.07 – 0.15	0.3
	Tip clearance mm	0.11 – 0.14	0.3
Clutch and brake piston strokes	Overdrive clutch mm	1.74 – 2.44	–
	Forward clutch mm	1.40 – 1.60	–
	Direct clutch mm	0.90 – 1.30	–
	No.1 brake mm	0.78 – 1.32	–
	No.2 brake mm	1.03 – 1.65	–
Brake clearance	Overdrive brake mm	0.56 – 1.62	–
	No.3 brake mm	0.52 – 1.27	–
Throttle cable adjusting mark clearance mm		0.8 – 1.5	–
Resistance between solenoid valve terminal and solenoid valve body $\Omega$		10 – 16	–

**TRANSFER**

Item	Standard value (mm)	Limit value (mm)
2WD/4WD clutch end play	0 – 0.08	–
Input gear end play	0 – 0.06	–
Input gear bearing clearance	0 – 0.06	–
Hi-Lo clutch hub end play	0 – 0.08	–
Differential lock hub end play	0 – 0.08	–
Rear output shaft rear bearing clearance	0 – 0.08	–
Clearance between synchronizer outer ring back side and drive sprocket	–	0.3

## IDENTIFICATION OF SPRING

## VALVE BODY

Spring name		Free height mm	Outside diameter mm	Number of coils	Wire diameter mm	Identification color
Upper rear valve body	1-2 shift valve spring	29.15	8.90	10.0	0.90	Blue
	2-3 shift valve spring	29.15	8.90	10.0	0.90	Blue
	3-4 shift valve spring	29.15	8.90	10.0	0.90	Blue
	Reverse clutch sequence valve spring	37.55	9.1	12.34	1.10	Light blue
Upper front valve body	Throttle valve spring	21.94	8.58	8	0.71	–
	Down shift valve spring	39.55	10.90	9.39	1.20	Green
	Secondary regulator valve spring	71.27	17.43	15	1.93	Green
	Cutback valve spring	23.0	6.85	10.5	0.65	Green
Lower valve body	Lockup control valve spring	32.6	11.4	8.25	1.0	Green
	Pressure regulator valve spring	50.28	17.02	10.5	1.7	Blue
	Intermediate modulator valve spring	27.26	9.04	9.5	1.1	Green
	Low coast modulator valve spring	42.35	9.24	15	0.84	–
	Pressure relief valve spring	32.14	13.14	9	2.03	–
	Oil cooler bypass valve spring	28.90	13.80	6.5	1.60	Orange

## ACCUMULATOR

Spring name		Free height mm	Outside diameter mm	Number of coils	Wire diameter mm	Identification color
C1 accumulator piston spring	Outer	29.5	13.45	7	1.1	–
	Inner	57.18	17.5	14.59, 2.68	1.9	Pink
C2 accumulator piston spring <V4AW4-D-A, B>		55.18	15.22	12.5	2.7	Green
C2 accumulator piston spring <V4AW4-D-C>		55.18	15.94	11.4	2.5	Yellow + Blue
B2 accumulator piston spring <V4AW4-D-A, B>	Outer	17.5	13	3.57	1.3	Light blue
	Inner	56.4	18.79	9.2	2.4	Green
B2 accumulator piston spring <V4AW4-D-C>	Outer	17.5	12.5	4	1.6	Red
	Inner	57.06	18	11.2	2.2	Pink

## TORQUE SPECIFICATION

### TRANSMISSION

Items	Torque Nm
Center support mounting bolt	25
Valve body mounting bolt	10
Oil strainer mounting bolt	5.4
Solenoid valve connector lock plate	5.4
Oil pan mounting bolt	4.4
Transmission rear adaptor mounting bolt	34
Transmission housing M10 mounting bolt	34
Transmission housing M12 mounting bolt	57
Union	25
Oil temperature sensor mounting bolt	25
Inhibitor switch center locking nut	4.0
Inhibitor switch locking bolt	5.4
Transmission control lever mounting bolt	7.0
Oil pump mounting bolt	22
Stator support mounting bolt	7.0
Transfer mounting bolt	35

### TRANSFER

Items	Torque Nm
Transfer case plate to transfer case mounting bolt	35
Transfer case to transfer rear cover mounting bolt	35
Center bearing retainer mounting seal bolt	18
Interlock plunger seal bolt	35
Vehicle speed sensor mounting bolt	11
Transfer control housing mounting bolt	18
Select plunger seal bolt	32
Poppet seal bolt	35
Various detection switches	34

**SNAP RINGS AND SPACERS FOR ADJUSTMENT****TRANSFER****Snap ring (for adjustment of input gear end play)**

Thickness mm	Identification color	Part number
2.70	Purple	MD704204
2.75	Pink	MD704205
2.80	Yellow	MD704206
2.85	White	MD704207
2.90	Blue	MD704208

**Snap ring (for adjustment of input gear bearing clearance)**

Thickness mm	Identification color	Part number
2.30	None	MD704199
2.35	Red	MD704200
2.40	White	MD704201
2.45	Blue	MD704202
2.50	Green	MD704203

**Snap ring (for adjustment of Hi-Lo clutch hub end play)**

Thickness mm	Identification color	Part number
2.14	None	MD704212
2.21	Yellow	MD704213
2.28	White	MD704214
2.35	Blue	MD704215
2.42	Red	MD704216

**Snap ring (for adjustment of differential lock hub end play)**

Thickness mm	Identification color	Part number
2.56	None	MD738386
2.63	Red	MD738387
2.70	White	MD738388
2.77	Blue	MD738389
2.84	Yellow	MD738390
2.91	Green	MD738391
2.98	Purple	MD738392

**Snap ring (for adjustment of rear output shaft rear bearing clearance)**

Thickness mm	Identification color	Part number
2.18	Blue	MR388669
2.25	None	MR388670
2.32	Brown	MR388671
2.39	White	MR388672

**Snap ring (for adjustment of 2-4WD clutch hub end play)**

Thickness mm	Identification color	Part number
2.56	None	MD738393
2.63	Red	MD738394
2.70	White	MD738395
2.77	Blue	MD738396
2.84	Yellow	MD738397

**SEALANTS**

Item	Specified sealant
Transmission	
Oil pump bolt	3M ATD part No. 8660 or equivalent
Transfer	
Mating surface between transfer control housing and transfer rear cover	Mitsubishi genuine sealant part No. MD997740 or equivalent
Mating surface between transfer case plate and transfer case	
Mating surface between transfer case and transfer rear cover	
Air breather to transfer case mounting area	
Threads of the center bearing retainer seal bolt (when reused)	3M STUD locking part No. 4170 or equivalent
Threads of the interlock plunger seal bolt (when reused)	3M ATD part No. 8660 or equivalent
Threads of the select plunger seal bolt (when reused)	
Threads of the poppet seal bolt (when reused)	

**FORM-IN-PLACE GASKET**

The transmission has several areas where the form-in-place gasket (FIPG) is in use. To ensure that the gasket fully serves its purpose, it is necessary to observe some precautions when applying the gasket. Bead size, continuity and location are of paramount importance. Too thin a bead could cause leaks. Too thick a bead, on the other hand, could be squeezed out of location, causing blocking or narrowing of the fluid feed line. To eliminate the possibility of leaks from a joint, therefore, it is absolutely necessary to apply the gasket evenly without a break, while observing the correct bead size.

Since the RTV hardens as it reacts with the moisture in the atmospheric air, it is normally used in the metallic flange areas.

**Disassembly**

The parts assembled with the FIPG can be easily disassembled without use of a special method. In some cases, however, the sealant between the joined surfaces may have to be broken by lightly striking with a mallet or similar tool. A flat and thin gasket scraper may be lightly hammered in between the joined surfaces. In this case, however, care must be taken to prevent damage to the joined surfaces.

**Surface preparation**

Thoroughly remove all substances deposited on the gasket application surfaces, using a gasket scraper or wire brush. Check to ensure that the surfaces to which the FIPG is to be applied is flat. Make sure that there are no oils, greases and foreign substances deposited on the application surfaces. Do not forget to remove the old sealant remained in the bolt holes.

**Form-in-place gasket application**

When assembling parts with the FIPG, you must observe some precautions, but the procedure is very simple as in the case of a conventional pre-cut gasket.

Applied FIPG bead should be of the specified size and without breaks. Also be sure to encircle the bolt hole circumference with a completely continuous bead. The FIPG can be wiped away unless it is hardened. While the FIPG is still moist (in less than 15 minutes), mount the parts in position. When the parts are mounted, make sure that the gasket is applied to the required area only. In addition, do not apply any oil or water to the sealing locations or start the engine until a sufficient amount of time (about one hour) has passed after installation is completed.

The FIPG application procedure may vary on different areas. Observe the procedure described in the text when applying the FIPG.

**LUBRICANTS****TRANSFER**

Item	Specified lubricant
Lip of the transfer case plate's oil seal	Mitsubishi genuine grease part No. 0101011 or equivalent
Lip of the transfer case's oil seal	
Lip of the transfer rear cover's oil seal	
Wave spring	
Spline section of the transfer input shaft	
Synchronizer cone surface	Hypoid gear oil SAE 75W-85W conforming to API classification GL-4 or higher

## 2. SPECIAL TOOLS

### TRANSMISSION

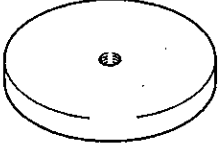
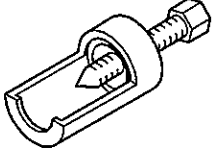
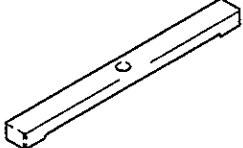
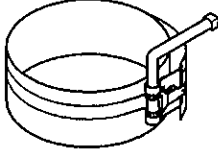
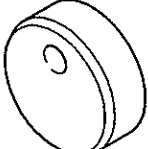
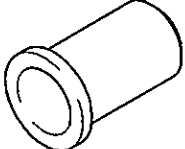
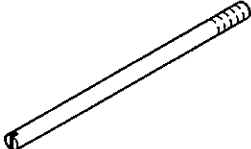
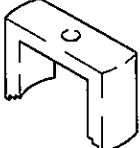

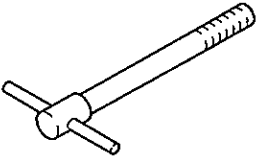
Tool	Number	Name	Use
	MD998211	Retainer	Disassembly and reassembly of No.3 brake
	MD998212	Oil pump puller	Removal of the oil pump
	MD998217	Gauge	Inspection of assembly condition
	MD998335	Oil pump band	Assembly of the oil pump
	MD998381	Oil seal installer	Assembly of oil seals
	MD998382	Oil seal installer	Assembly of oil seals
	MD998412	Guide	Installation of the oil pump
	MD998903	Spring compressor	Disassembly and reassembly of clutches

Tool	Number	Name	Use
	MD998904	Bolt	Disassembly and reassembly of clutches

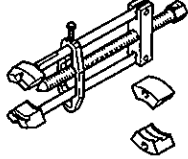
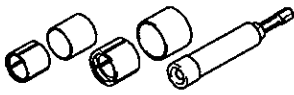
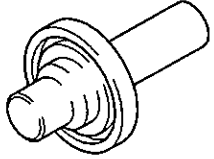
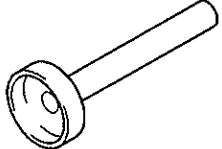
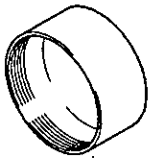
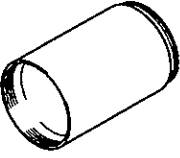
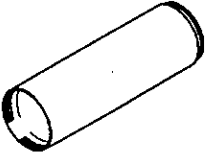
**TRANSFER**

Tool	Number	Name	Use
	MD998020	Bearing puller	Removal of ball bearings
	MD998192	Bearing puller	Installation of the center bearing
	MD998800	Oil seal installer	Installation of oil seals
	MD998803	Differential oil seal installer	Installation of oil seals
	MD998812	Installer cap	Used with installer and installer adaptor
	MD998813	Installer (100)	Used with installer cap and installer adaptor
	MD998814	Installer (200)	Used with installer cap and installer adaptor

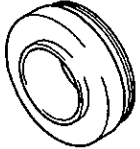
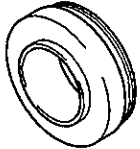
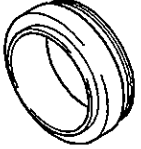

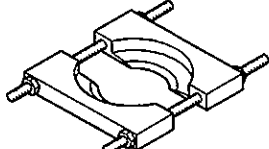
Tool	Number	Name	Use
	MD998818	Installer adaptor (38)	Installation of ball bearings
	MD998819	Installer adaptor (40)	Installation of ball bearings
	MD998825	Installer adaptor (52)	Installation of the input gear bearing
	MD998830	Installer adaptor (66)	Mounting of the oil guide and center bearing
	MD998917	Bearing remover	Removal of ball bearing and center bearing

---

**NOTES**

### 3. TRANSMISSION

#### DISASSEMBLY

##### Caution

- The automatic transmission contains high precision components. The utmost care must be taken to ensure that these components are not damaged in any way during the disassembly procedure.
- Perform the following procedures using bare hands or plastic gloves; cotton gloves must not be used. In addition, although nylon cloth or paper towels may be used when necessary, rags must not be used.
- All disassembled components must be cleaned. Although metal parts may be cleaned using a regular detergent, they must be dried off thoroughly using compressed air.
- Clutch discs, plastic thrust races, and rubber components must be cleaned using automatic transmission fluid (ATF). While cleaning, ensure that no dirt or foreign object become attached to these components.
- If the transmission proper is damaged, the cooler system must also be disassembled and cleaned.

1. Place the transmission on the work surface with the oil pan facing downward. Remove the transfer.

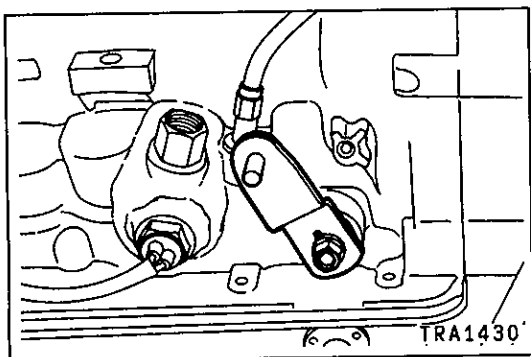

##### Caution

- As there is a danger that any foreign objects and dirt contained in the oil pan could enter the valve body or other similar components, the transmission should not be positioned with the oil pan mounting side upward before the oil pan is removed.
2. Remove the nut and spring washer followed by the transmission control shaft lever.
  3. Bend back the locking tabs of the inhibitor switch neutral adjustment plate; then remove the lock nut.
  4. Remove the neutral adjustment plate and the packing.

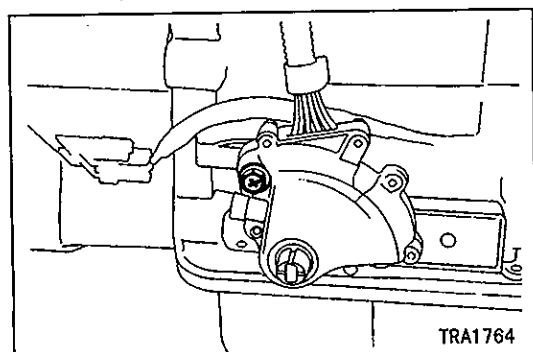
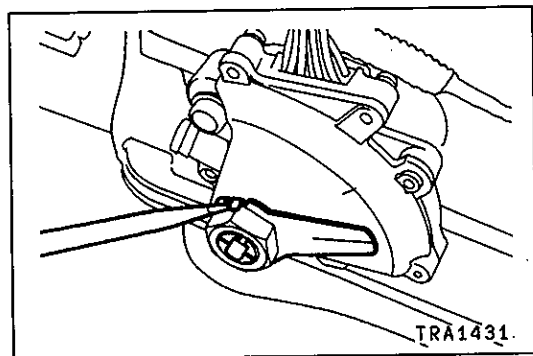

5. Remove the inhibitor switch.

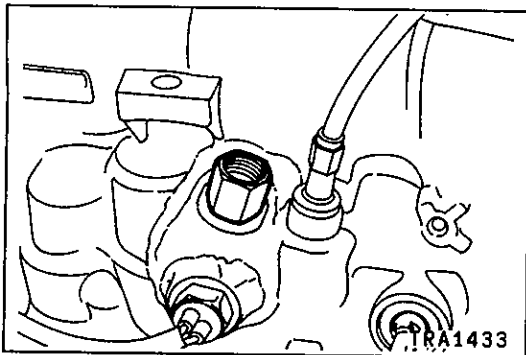

6. Remove the union (front side) and its O-ring.

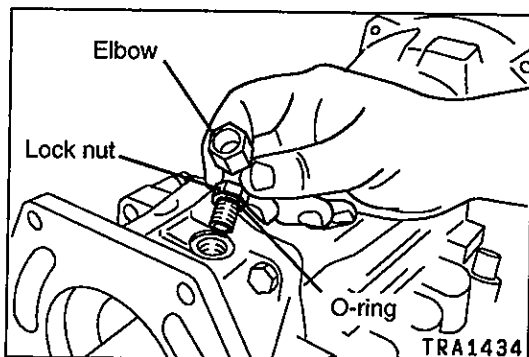

7. Loosen the lock nut; then remove the elbow and its O-ring.

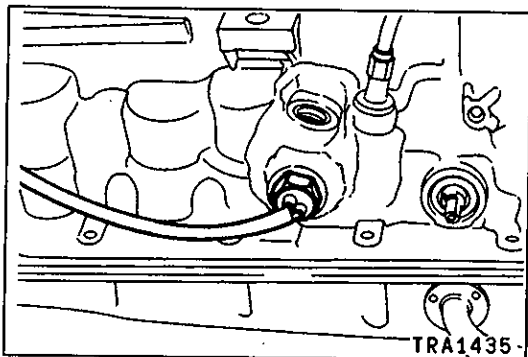

8. Remove the oil temperature sensor and its O-ring.

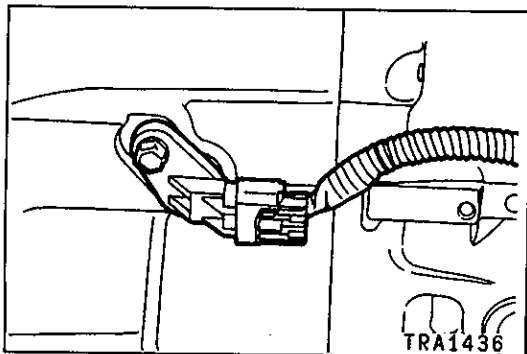

9. Remove the input speed sensor and its O-ring.

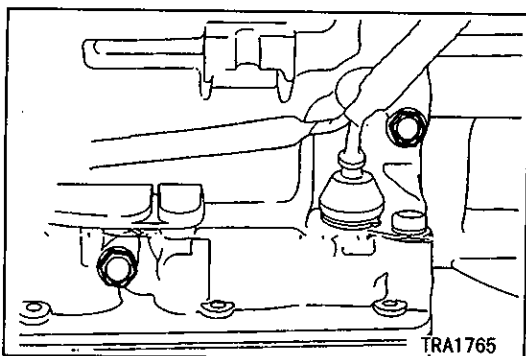

10. Remove each transmission case plug and its O-ring. (2 locations)

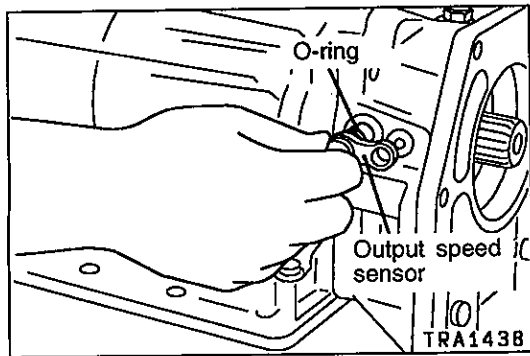

11. Remove the output speed sensor and its O-ring.

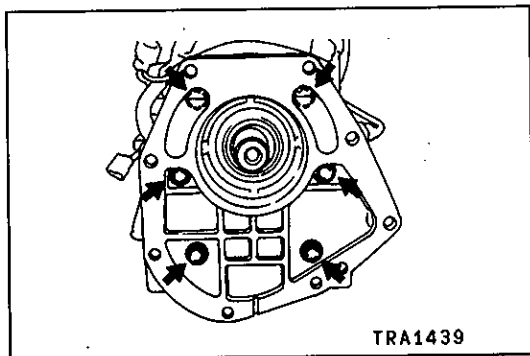

12. Remove the bolts shown in the illustration; then remove the transmission adaptor and gasket.  
13. Remove the oil seal.

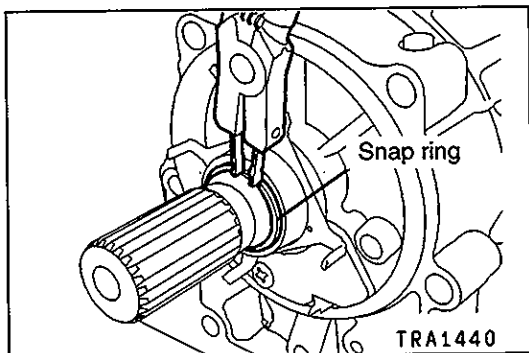

14. Remove the snap ring.

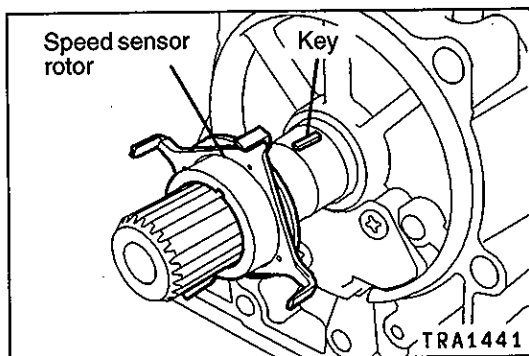

15. Remove the speed sensor rotor and the key.

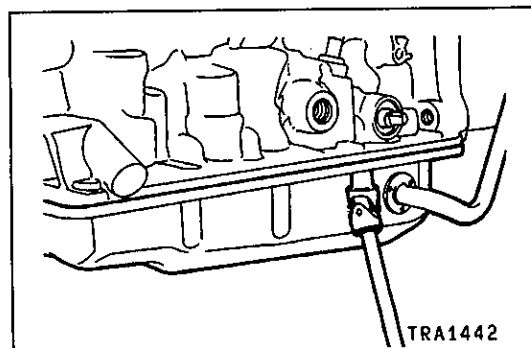

16. Remove the oil pan, the gasket, and the magnets.

**Caution**

- As there is a danger that any foreign objects and dirt contained in the oil pan could enter the valve body or other similar components, the transmission should not be positioned with the oil pan mounting side upward before the oil pan is removed.

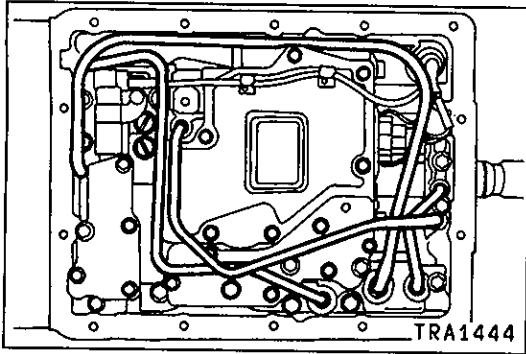

17. Pull out both ends of the oil tube little by little, finally removing the oil tube completely.

**Caution**

- The oil tube must not be distorted or deformed by bending.

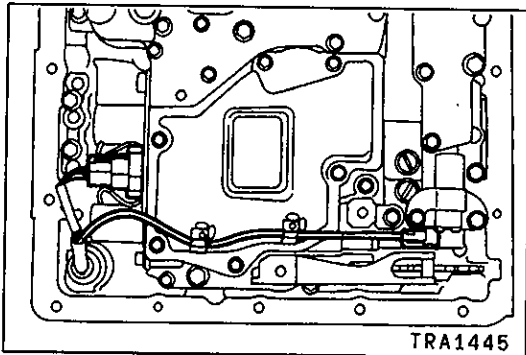

18. Remove the connector from the solenoid valve; then the harness from the harness clamp.

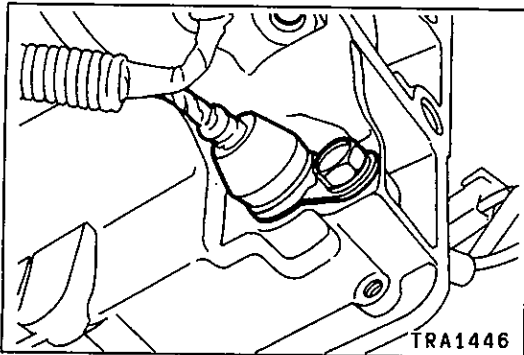

19. Remove the lock plate and then the solenoid valve harness.  
20. Remove the O-ring from the solenoid valve harness.

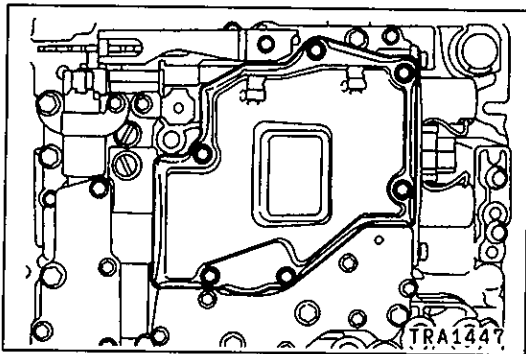

21. Remove the bolts shown in the illustration; then remove the oil strainer, the spacer, and the gasket.

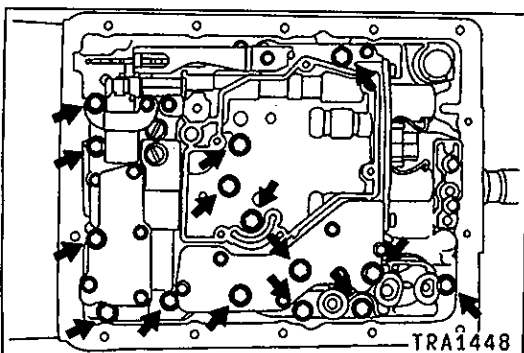

22. Loosen uniformly the bolts indicated in the illustration on the left. Then remove the bolts.

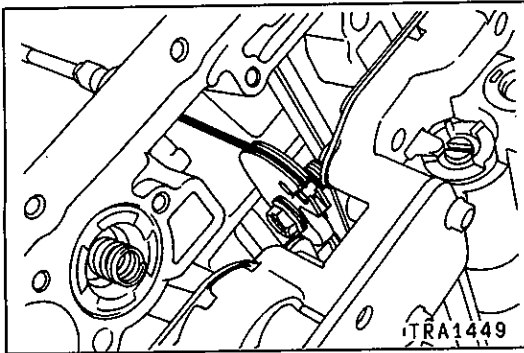

23. Lift up the valve body and remove the throttle cable from the throttle cam.
24. Remove the valve body.

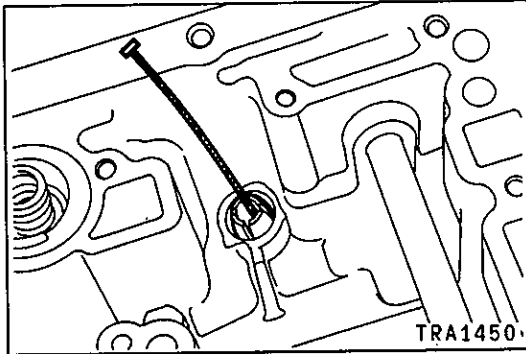

25. Remove the throttle cable.

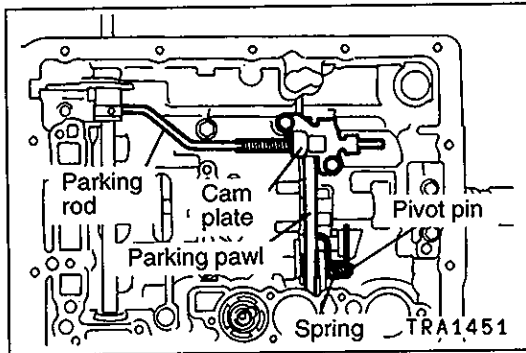

26. Remove the cam plate, the spring, the pivot pin, the parking pawl, and the parking rod.

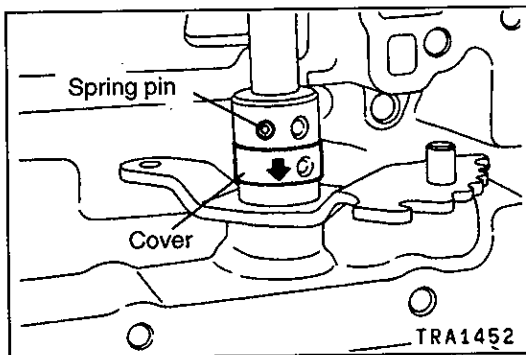

27. Move the cover and tap out the spring pin.
28. Remove the shaft and the manual valve lever.

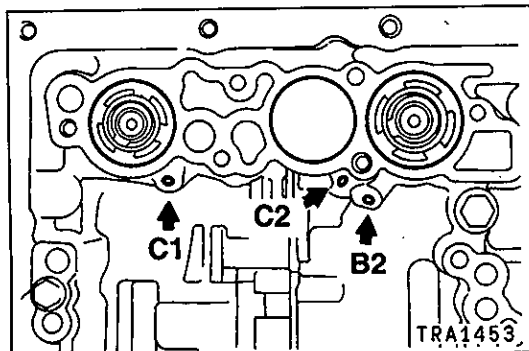

29. Blow in air at the points indicated in the illustration on the left to remove the accumulator pistons.

#### Caution

- There is a danger that the piston and fluid may fly out at a considerable speed: Take the necessary precautions.
- Pistons and springs are assembled in the order B2, C2, C1 from the front side. They should be stored in this order following removal.

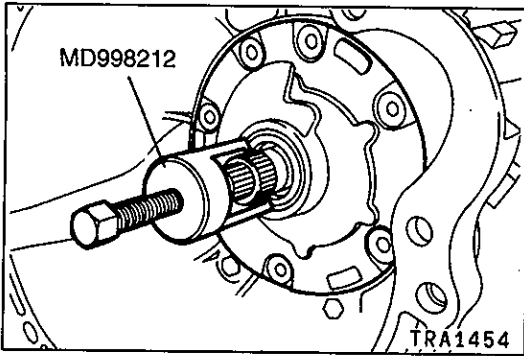

30. Remove the oil pump mounting bolts; then remove the oil pump using the appropriate special tool.
31. Remove the thrust bearing and the thrust race.

**NOTE**

There may be a case where the thrust race is stuck to the oil pump side.

32. Remove the converter housing mounting bolts.
33. Remove the converter housing while manually holding down the overdrive input shaft.

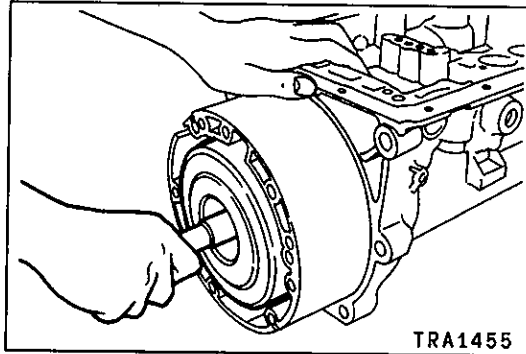

34. Remove the overdrive input shaft, the overdrive planetary gear, and the overdrive clutch from the overdrive case.
35. Remove the two thrust washers.

**NOTE**

There may be a case where the thrust washer is stuck to the overdrive planetary gear side.

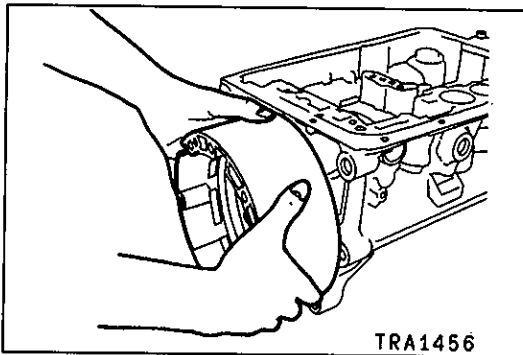

36. Remove the overdrive case.
37. Remove the thrust race and the thrust bearing.

**NOTE**

There may be a case where the thrust race is stuck to the overdrive case side.

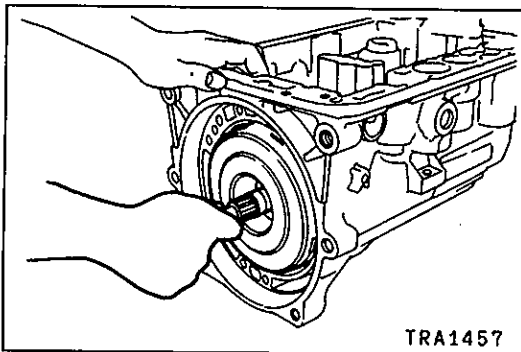

38. Remove the forward clutch.
39. Remove the thrust bearing, and the two thrust races.

**NOTE**

There may be a case where the thrust race is stuck to the forward clutch side.

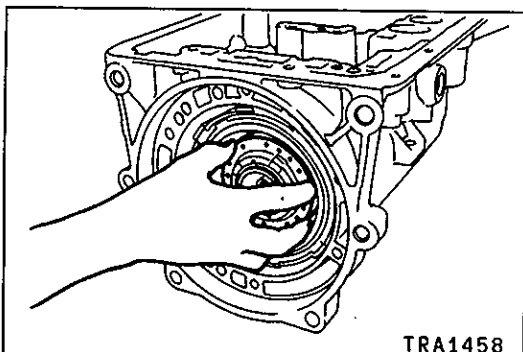

40. Remove the direct clutch.



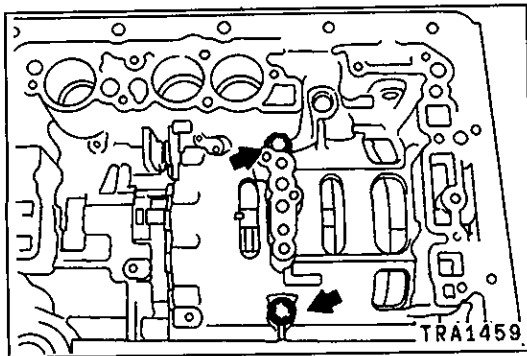

41. Remove the center support mounting bolts.

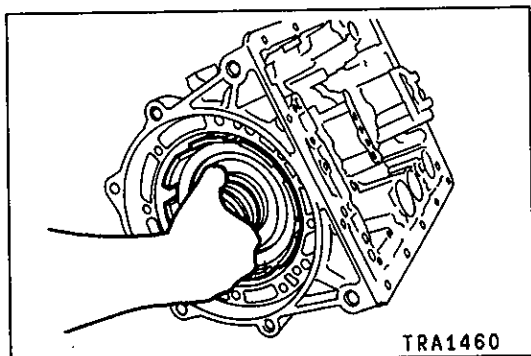

42. Remove the center support and the sun gear as a unit.

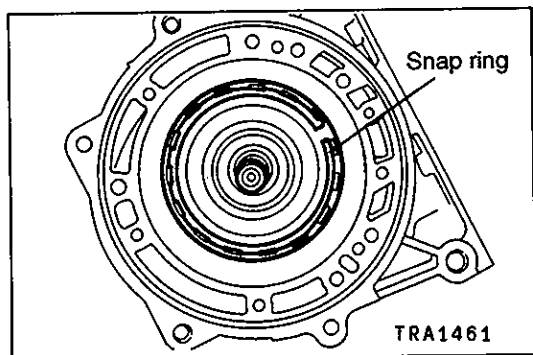

43. Remove the snap ring.

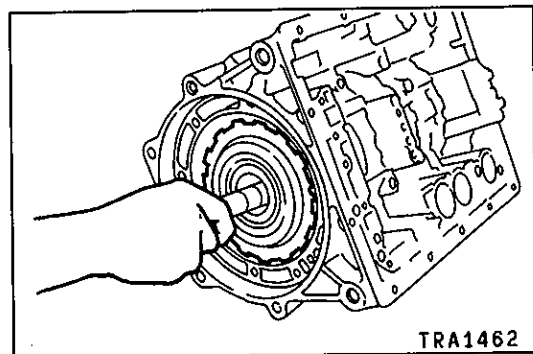

44. Hold the intermediate shaft and remove both the front planetary gear and the rear planetary gear.

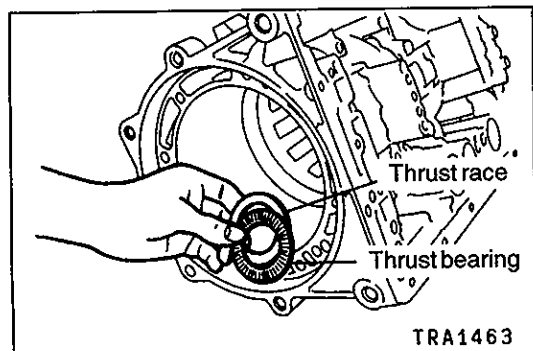

45. Remove the thrust bearing and the thrust race.

**NOTE**

There may be a case where the thrust bearing is stuck to the rear planetary carrier side.

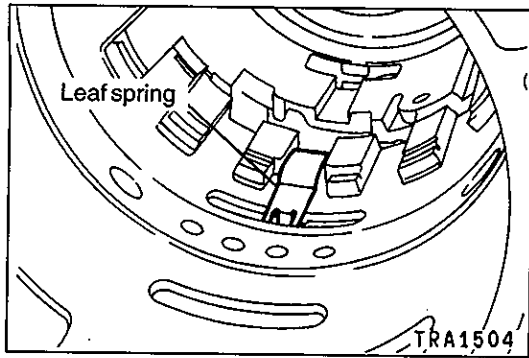

46. Remove the leaf spring.

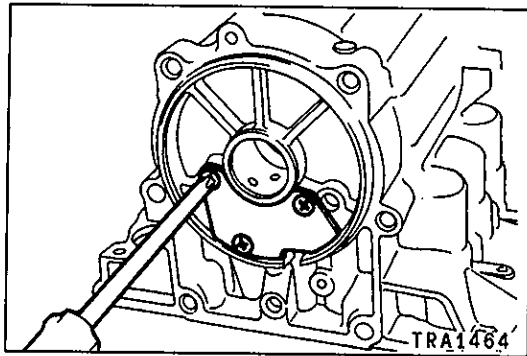

47. Remove the rear cover and the gasket.

## REASSEMBLY

### Caution

- The automatic transmission contains high precision components. The utmost care must be taken to ensure that these components are not damaged in any way during the assembly procedure.
- Damage can lead to leakage of automatic transmission fluid (ATF) or to performance being impaired. Consequently, assembly operations should be performed with care and while inspecting carefully for damage.
- Frictional elements, rotating sections, and sliding sections should be coated with ATF before reassembly.
- All disassembled components must be cleaned. Although metal parts may be cleaned using a regular detergent, they must be dried off thoroughly using compressed air.
- Clutch discs, plastic thrust races, and rubber components must be cleaned using ATF. While cleaning, ensure that no dirt or foreign object become attached to these components.
- Gaskets, oil seals, and other similar rubber parts cannot be reused. They should always be replaced with new parts for assembly.
- When new clutch discs or brake discs are to be assembled, they must be soaked in ATF for at least 2 hours in advance.
- Sealant or adhesive must not be used with gaskets.
- Greases other than petrolatum or industrial vaseline must never be used.
- If a bushing should be replaced, replace the assembly containing that bushing.

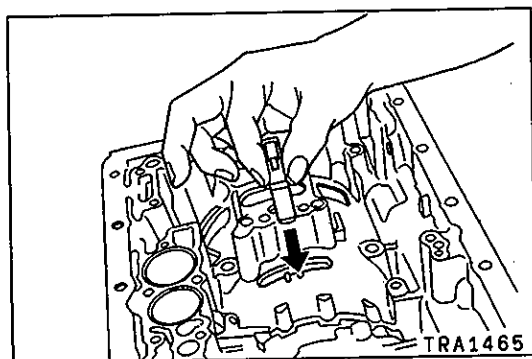

1. Install the leaf spring.

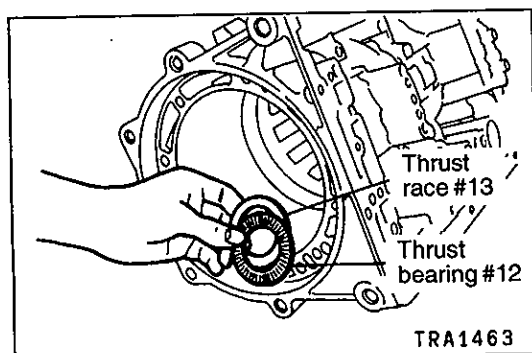

2. Assemble thrust race #13 and thrust bearing #12.

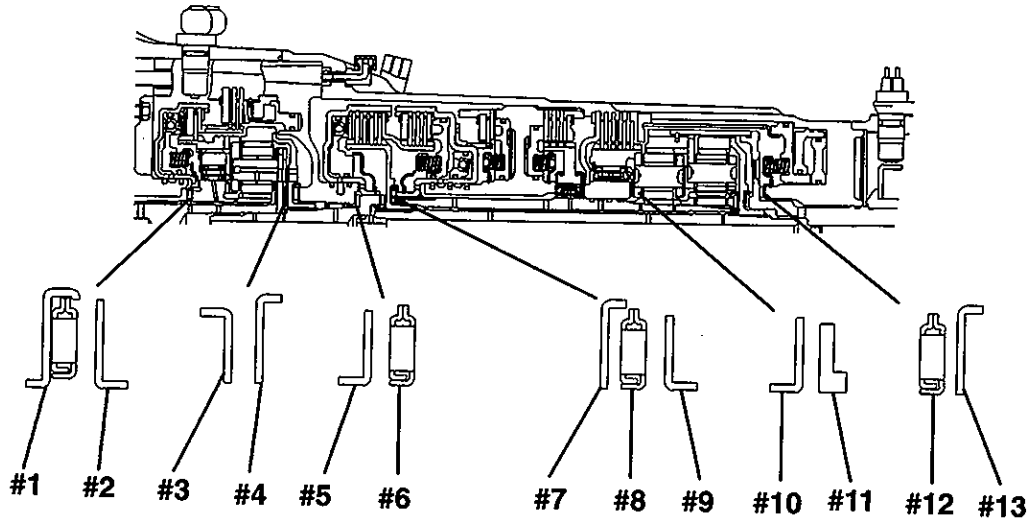

TRA1466

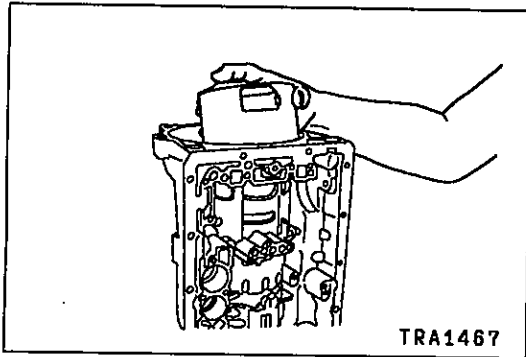

TRA1467

3. Install the apply-tube.

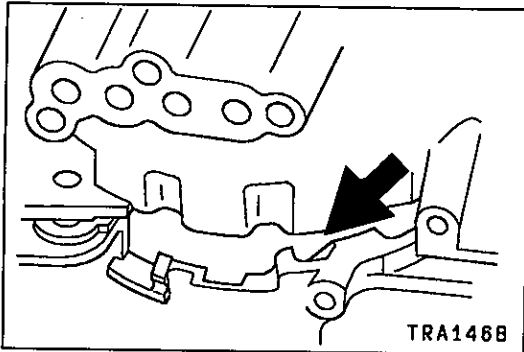

TRA1468

**Caution**

- Fit the apply-tube lug securely in the case at the position shown in the illustration.

4. Mount the thrust washer #11 to the rear planetary carrier.

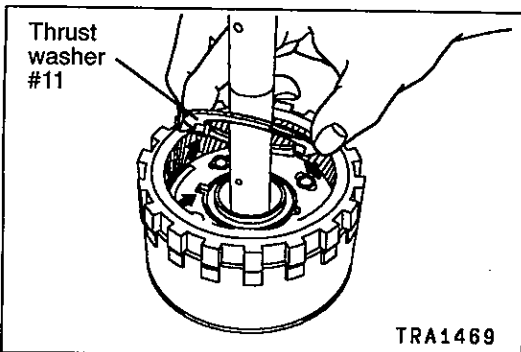

TRA1469

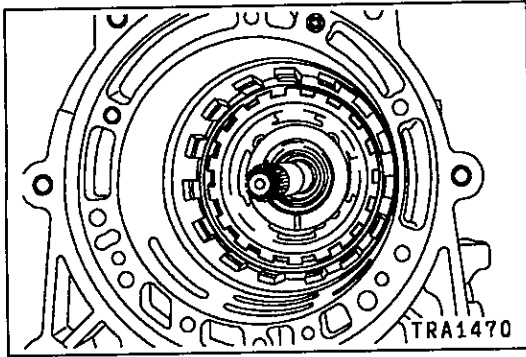

5. Attach the rear planetary carrier.

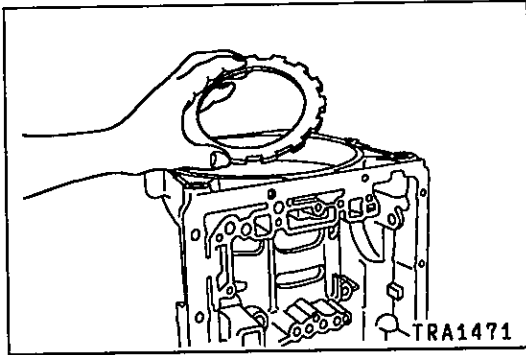

6. Install the backing plate.

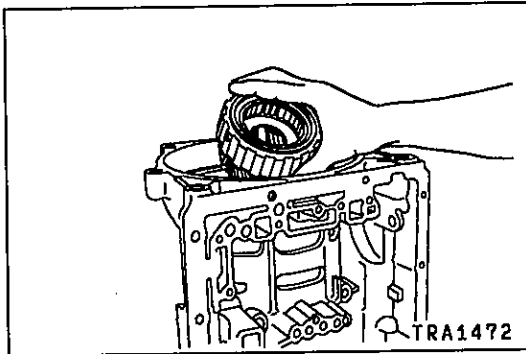

7. Coat the thrust washer #10 with petrolatum or vaseline and then attach it to the front planetary carrier. Following this, install the front planetary carrier in the ring gear of the rear planetary carrier.

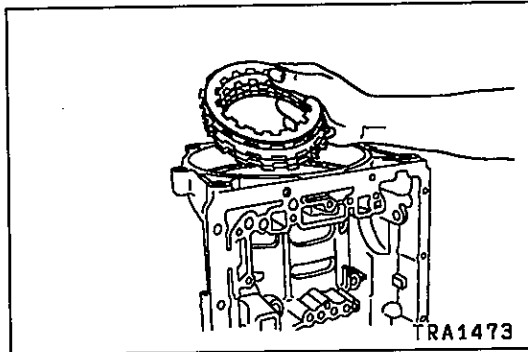

8. Install the clutch discs and the clutch plates alternately onto the backing plate.

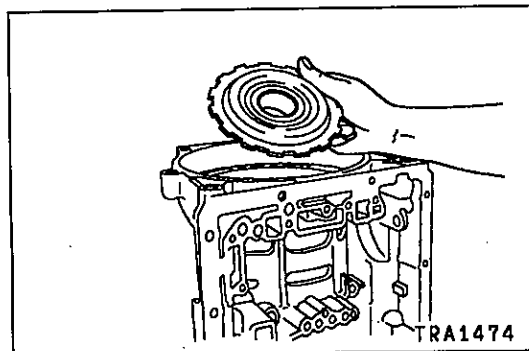

9. Install the inner race.

**Caution**

- The inner race must be installed in such a way that the illustrated marker is facing the valve body side.
- The snap ring groove should be completely visible when the carriers and the inner race have been assembled. Verify that this is the case.

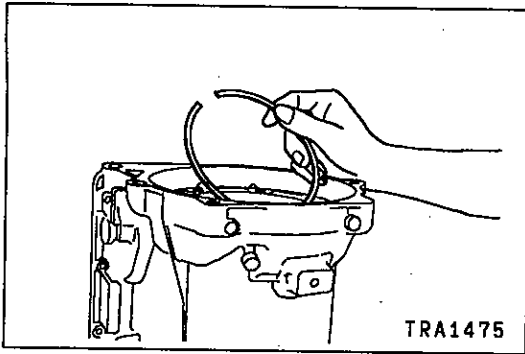

10. Install the snap ring.

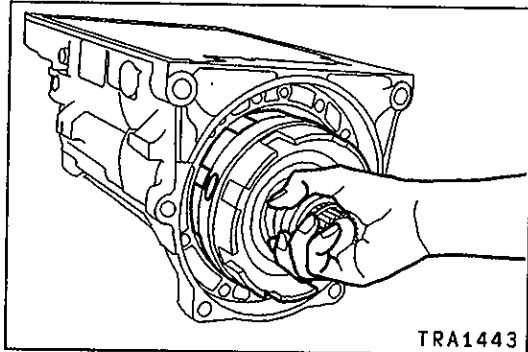

11. Install the center support.

**Caution**

- The center support mounting bolt holes should be lined up before the center support is pushed into place.

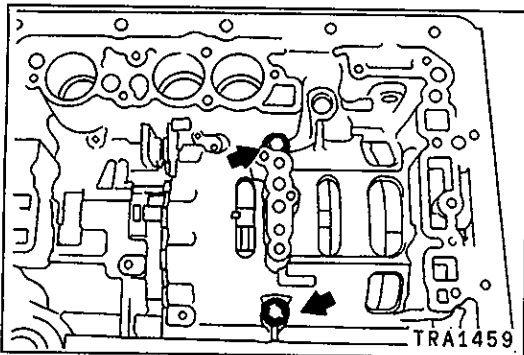

12. Tighten the indicated bolts handtight while the center support is being pushed into place.

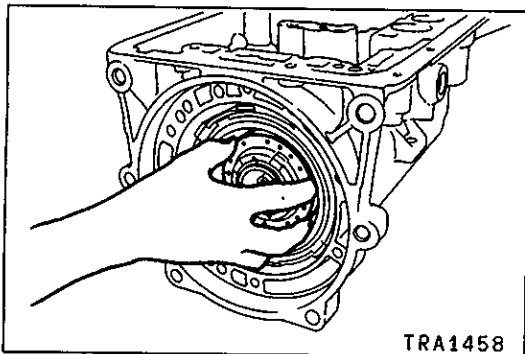

13. Attach the direct clutch.

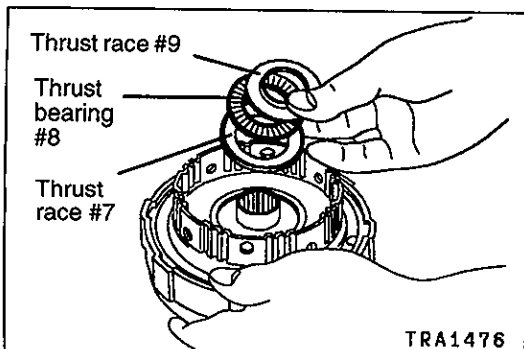

14. Coat the thrust race #7, the thrust bearing #8, and the thrust race #9 with petrolatum or vaseline and attach to the forward clutch hub.

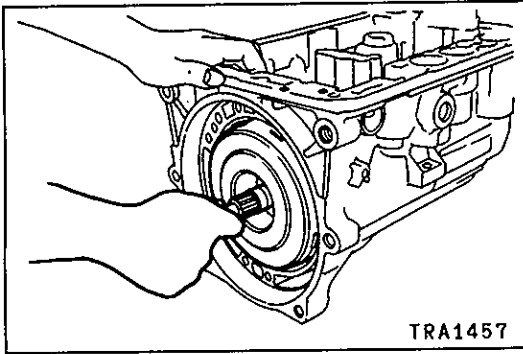

15. Attach the forward clutch while aligning with the lugs of the direct clutch discs.

**Caution**

- Ensure that the thrust races and the thrust bearing which were attached in the previous step do not fall off during this step.

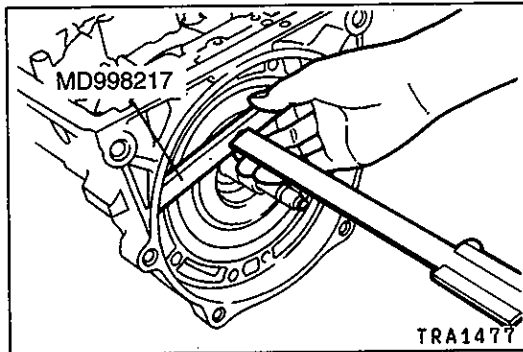

16. Measure the distance to the forward clutch from the front end face of the special tool and verify that the correct installation condition has been achieved.

**Standard value (i.e., measured value – thickness of special tool): Approx. 1.5 mm**

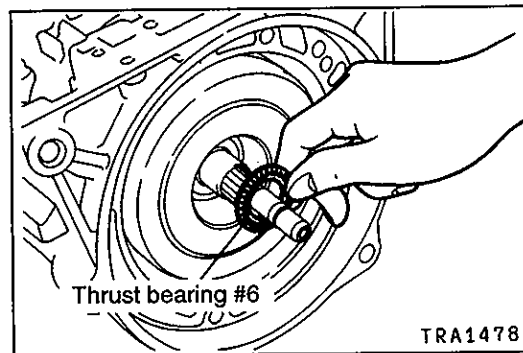

17. Attach the thrust bearing #6 to the forward clutch.

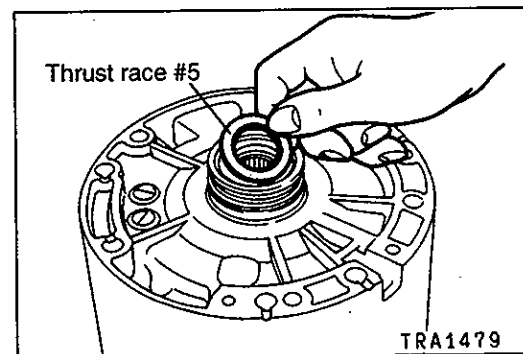

18. Apply either petrolatum or vaseline to the thrust race #5; then attach it to the overdrive case.

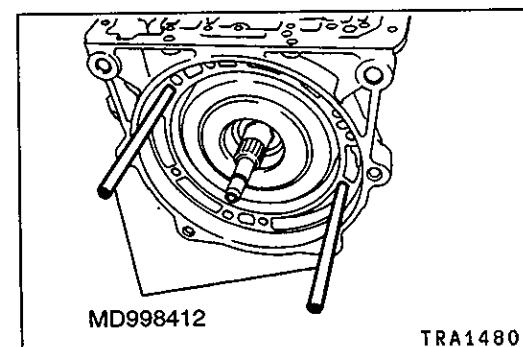

19. Attach the indicated special tools to the transmission case.

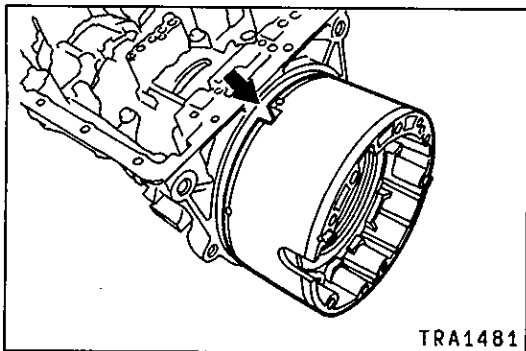

20. Pass the overdrive case along the two special tools with the notch in the case directed as shown and carefully attach to the transmission case.

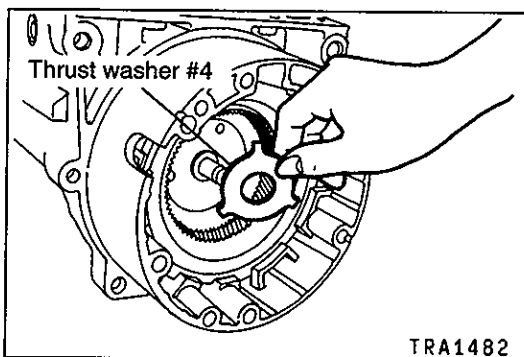

21. Mount the thrust washer #4 in the ring gear located inside the overdrive case.

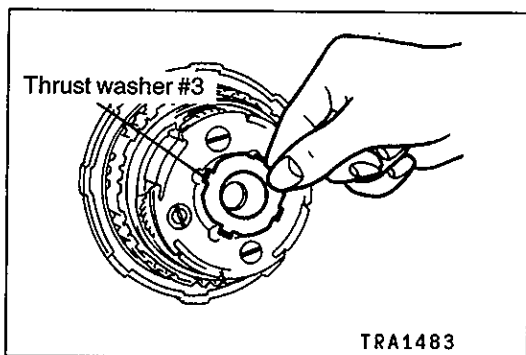

22. Assemble the overdrive clutch and the overdrive planetary gear, apply either petrolatum or vaseline to the thrust washer #3, and attach this washer to the overdrive planetary carrier.

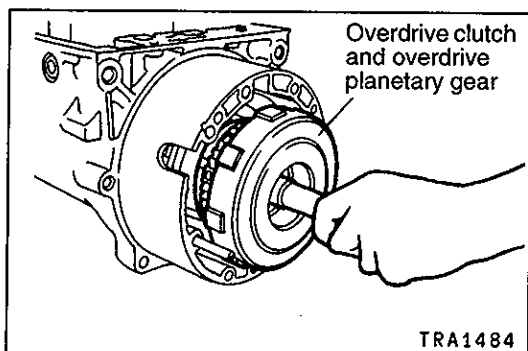

23. Align the lugs of the overdrive brake discs with each other; following this, install the overdrive clutch and the overdrive planetary gear which were assembled the last step.

#### Caution

- Ensure that the thrust washer which was attached in the previous step does not fall off during this step.

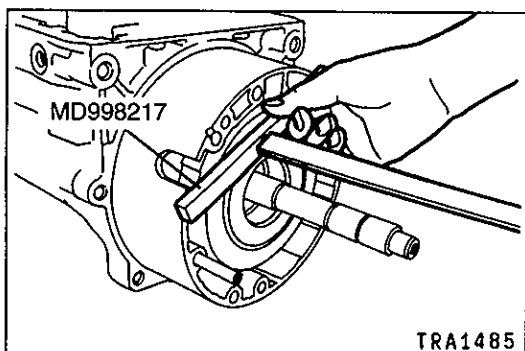

24. Measure the distance to the overdrive clutch from the front end face of the special tool and verify that the correct installation condition has been achieved.

**Standard value (i.e., measured value – thickness of special tool): Approx. 2.0 mm**



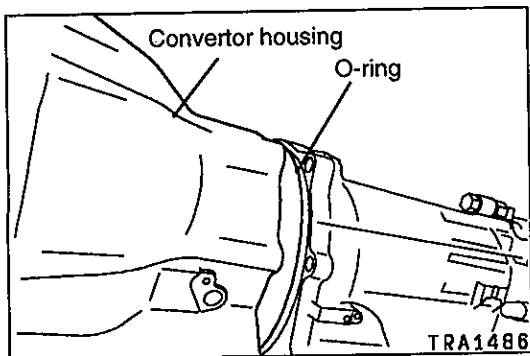

25. Install the O-ring and then the convertor housing.

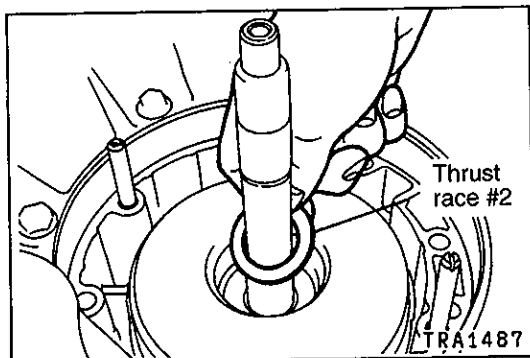

26. Attach the thrust race #2 to the overdrive clutch.

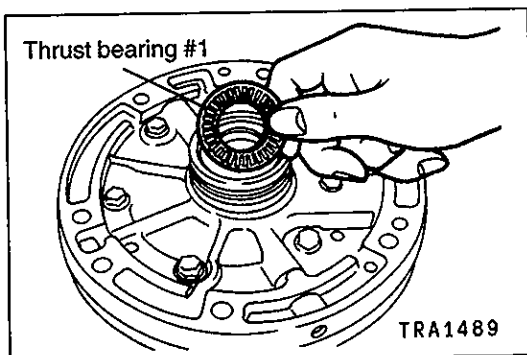

27. Apply either petrolatum or vaseline to the thrust bearing #1; then attach it to the oil pump.

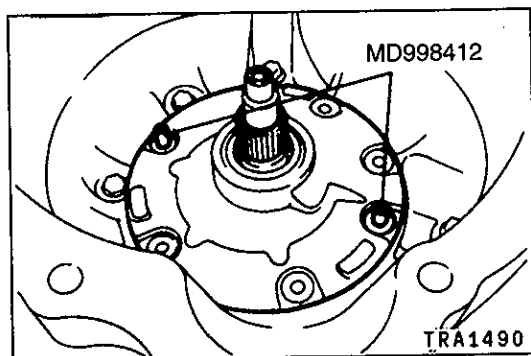

28. Attach the oil pump using the indicated special tools as guides.

**Caution**

- Ensure that the thrust washer which was attached in the previous step does not fall off during this step.

29. Mount the bolts after sealant has been applied to them.

**Specified sealant: 3M ART Part No. 8660 or equivalent**

**Caution**

- Bolts should be tightened gradually and uniformly.
- The input shaft end play should be checked continually as the bolts are being tightened.

**Standard value: 0.3 – 0.9 mm**

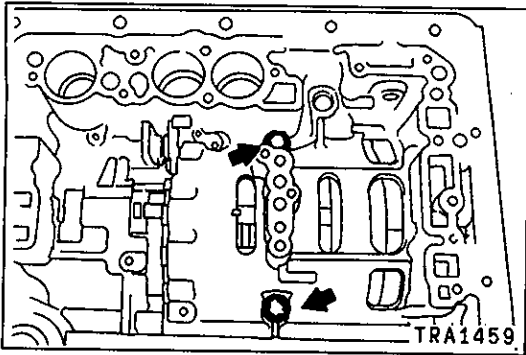

30. Alternately tighten the center support mounting bolts little by little.

**NOTE**

Start tightening from the bolt on the accumulator side.

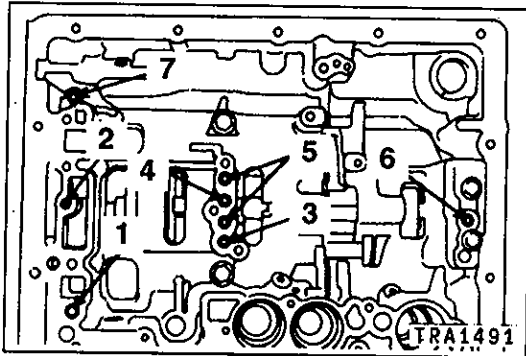

31. Blow in low pressure air at the points indicated in the illustration and confirm that each piston can be heard to operate.

1. Overdrive clutch
2. Forward clutch
3. Brake No.1
4. Brake No.2
5. Direct clutch
6. Brake No.3
7. Overdrive brake

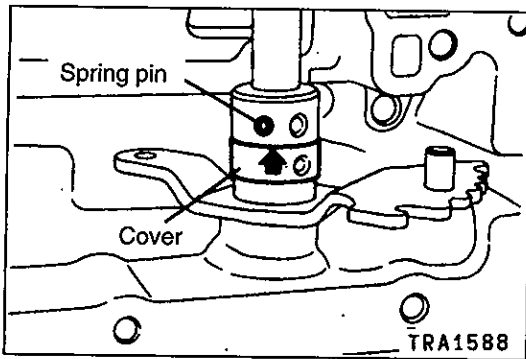

32. Insert the manual lever shaft into the case, attach the manual lever and the cover to the shaft, and tap the spring pin into place.

33. Move the cover up over the spring pin and stake it in position.

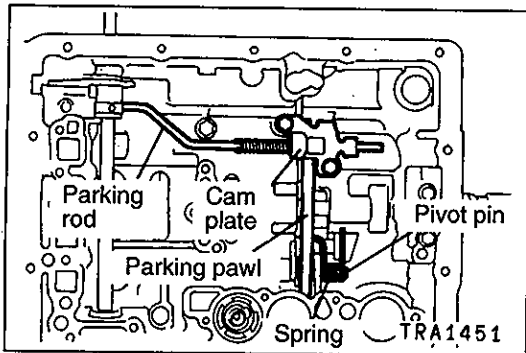

34. Install the parking rod, parking pawl, pivot pin, spring, and cam plate.

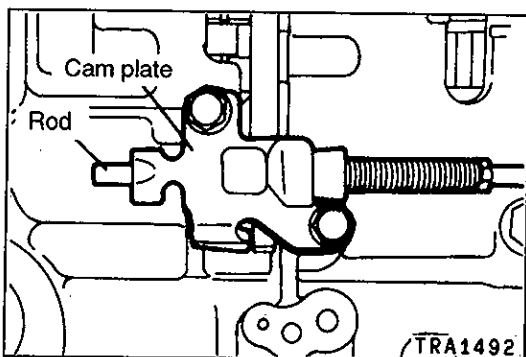

**Caution**

- Verify that the rod is protruding from the cam plate.

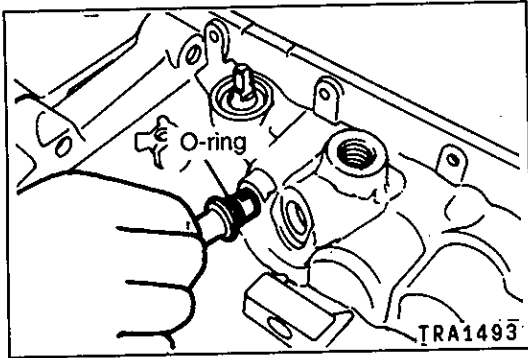

35. Insert a new O-ring and attach the throttle cable.

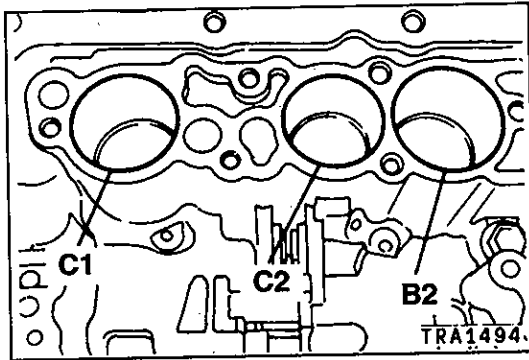

36. Install each accumulator piston and spring.

**Accumulator piston dimensions**

	Piston outer diameter (mm)	Piston length (mm)
B2	34.80 – 34.85	48.50
C1	31.80 – 31.85	49.50
C2	31.80 – 31.85	45.00

**Accumulator spring dimensions**

**V4AW4-D-A, B**

	Free height (mm)	Outside diameter (mm)	Identification color
B2	17.5	13.0	Light blue
	56.4	18.79	Green
C1	29.5	13.45	–
	57.18	17.5	Pink
C2	55.18	15.22	Green

**V4AW4-D-C**

	Free height (mm)	Outside diameter (mm)	Identification color
B2	17.5	12.5	Red
	57.06	18	Pink
C1	29.5	13.45	–
	57.18	17.5	Pink
C2	55.18	15.94	Yellow + Blue

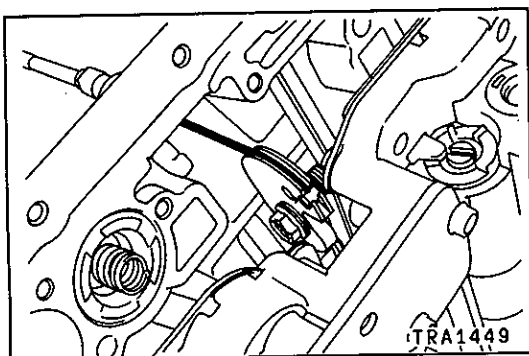

37. Place the valve body on the transmission case and connect the throttle cable to the throttle cam.

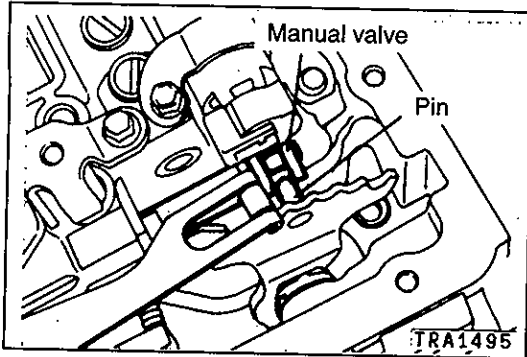

38. Position the valve body in such a way that the manual valve lever pin sits in the manual valve groove.

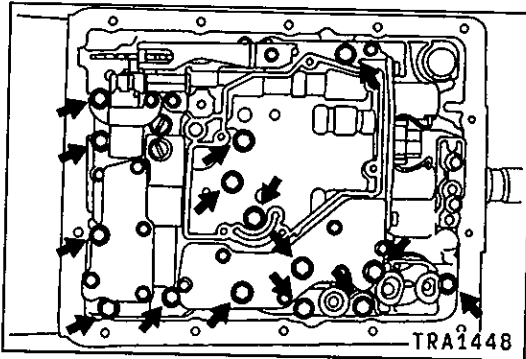

39. Install valve body mounting bolts in the indicated positions and tighten uniformly.

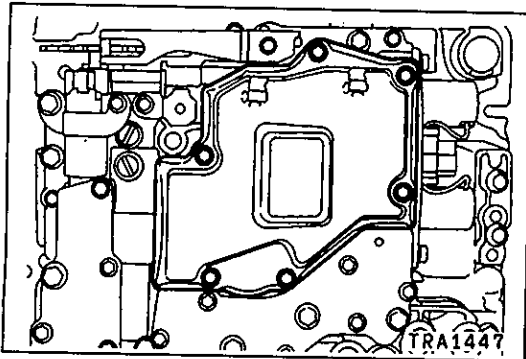

40. Attach the oil strainer, spacer, and gasket; tighten mounting bolts uniformly.

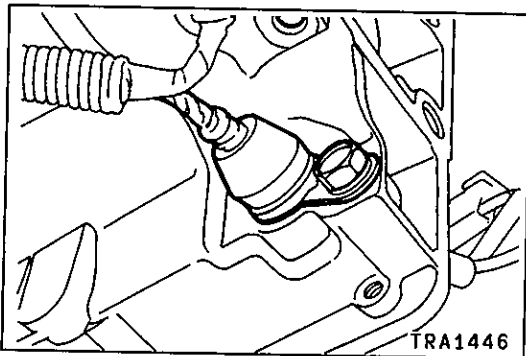

41. Install a new O-ring, apply automatic transmission fluid, and then place the solenoid valve harness inside the case.  
42. Attach the lock plate and secure using a bolt.

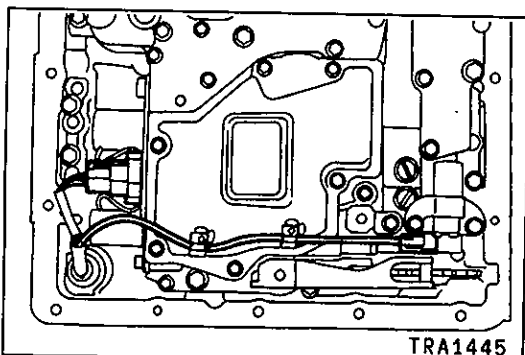

43. Attach the connector to the solenoid valve and secure the harness to the harness clamps.

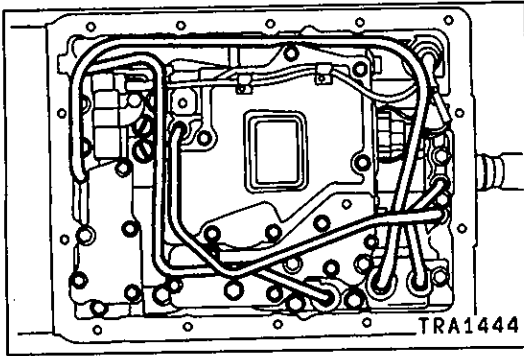

44. Use a plastic hammer or another similar tool to lightly and evenly tap the ends of the oil tube and secure it in place.

**Caution**

- Ensure that the oil tube is firmly fastened as far as the stopper position.

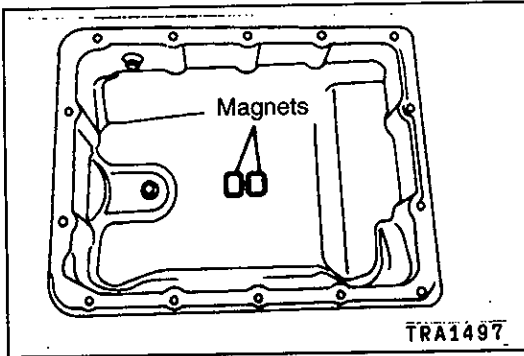

45. Attach the magnets at the positions indicated in the illustration.

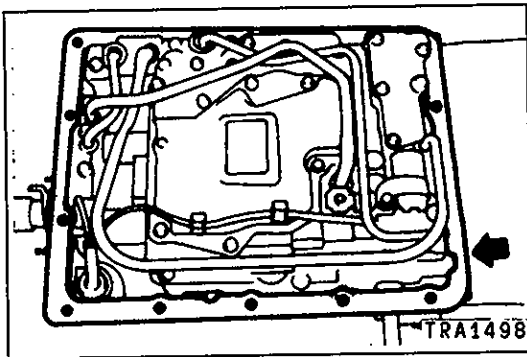

46. Attach a new gasket in such a way that the notch is positioned as illustrated.
47. Attach the oil pan and tighten the mounting bolts evenly.

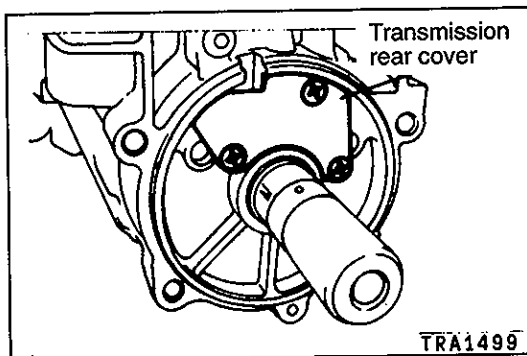

48. Attach the transmission case rear cover through a new gasket.

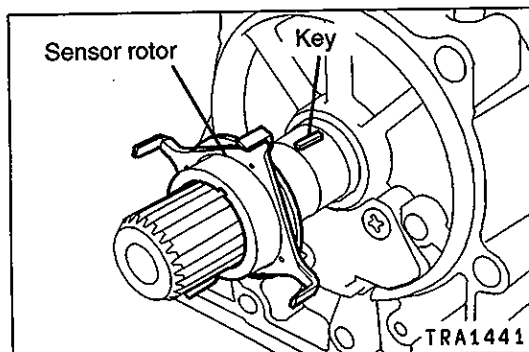

49. Mount the key and the sensor rotor on the output shaft.

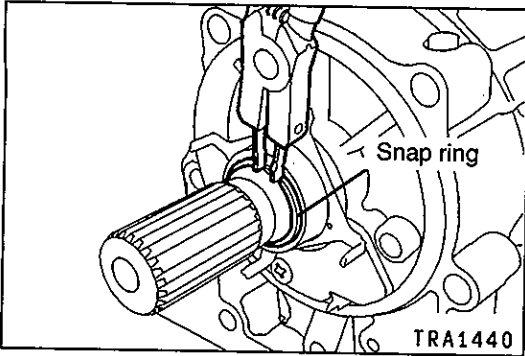

50. Attach the snap ring.

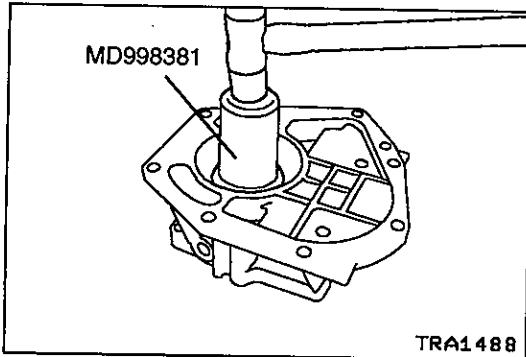

51. Install an oil seal in the transmission rear adaptor using the indicated special tool.

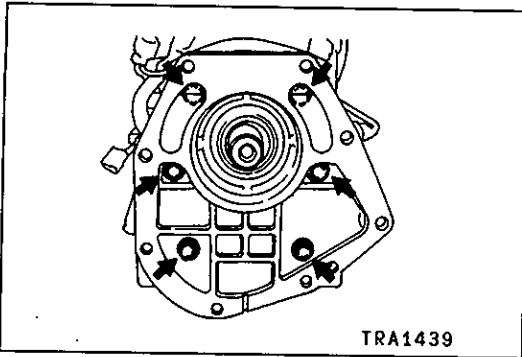

52. Mount the transmission rear adaptor through a new gasket.

**Caution**

- Take care not to damage the oil seal with the splined section of the output shaft.

53. Uniformly tighten the bolts indicated in the illustration.

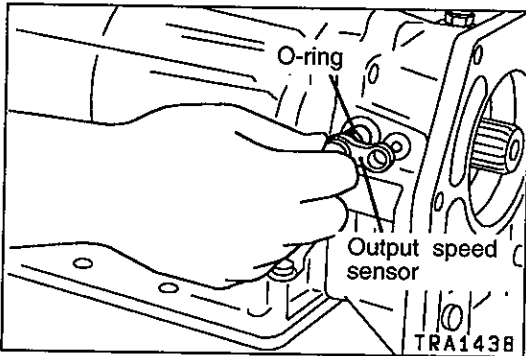

54. Attach a new O-ring to the output speed sensor; following this install the output speed sensor.

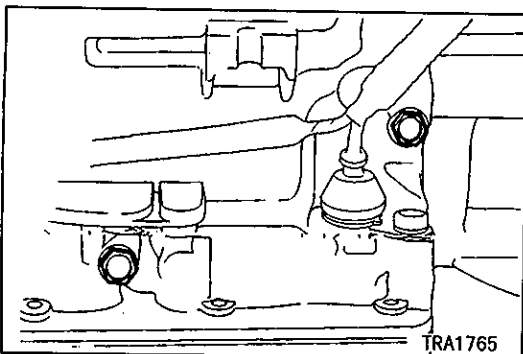

55. After installing a new O-ring into the transmission case plug, attach this plug.

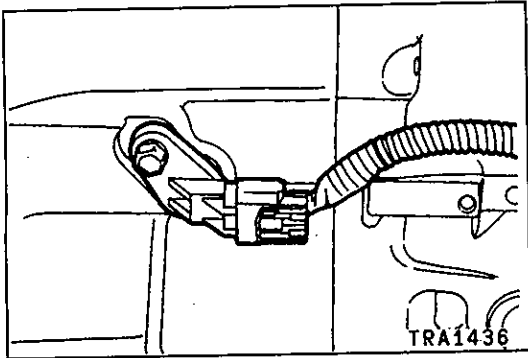

56. Install a new O-ring into the input speed sensor and attach this sensor.

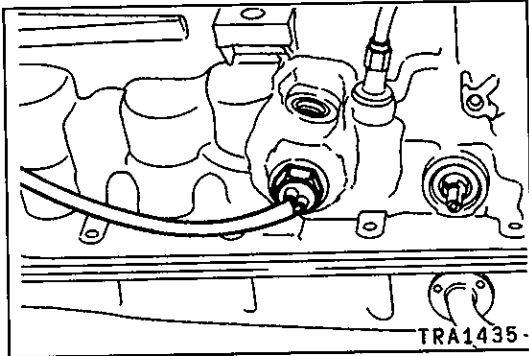

57. After installing a new O-ring into the oil temperature sensor, attach this sensor.

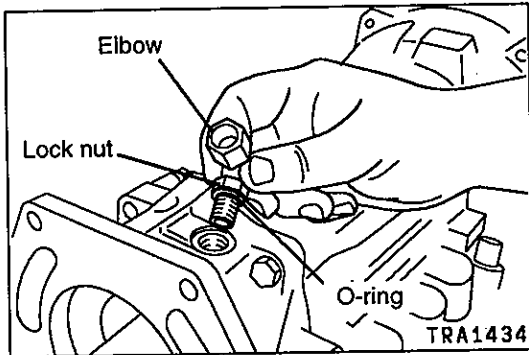

58. Install a new O-ring on the elbow, then attach the elbow.

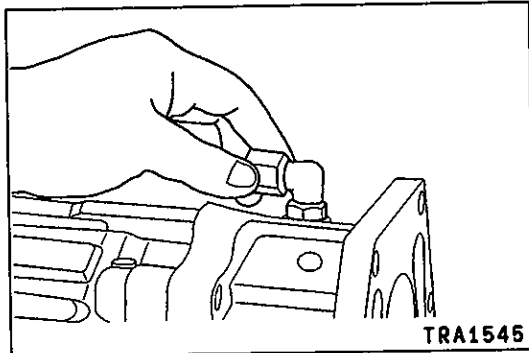

59. While holding the elbow in the forward facing position, tighten the lock nut.

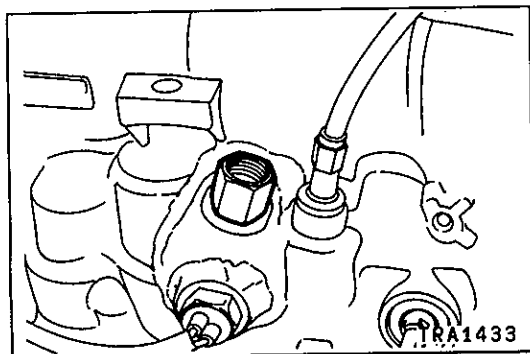

60. After installing a new O-ring into the union, attach the union.

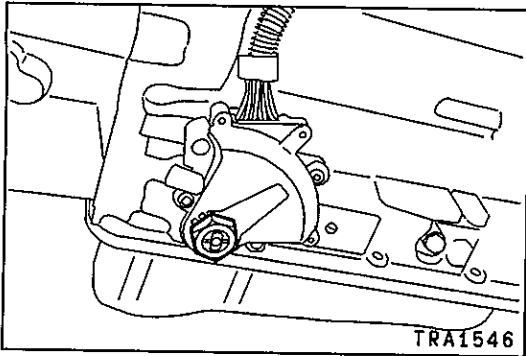

61. Attach the inhibitor switch to the manual valve lever shaft.
62. Fit the packing and neutral adjusting plate and secure with the mounting nut.

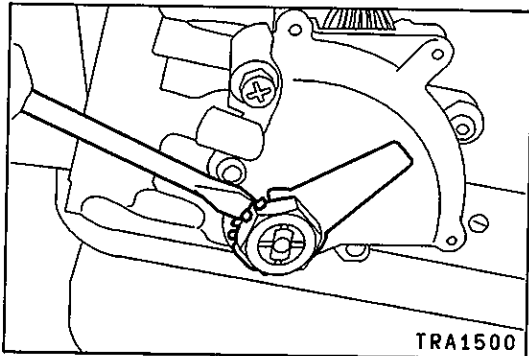

63. Using a screwdriver or something similar, bend the locking tabs of the neutral adjusting plate over the nut to lock it.

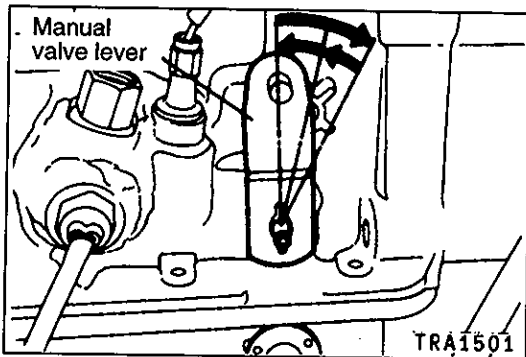

64. Temporarily attach the manual valve lever and rotate the manual valve lever shaft fully backwards; following this, return the lever by two detents to bring it to the neutral position.

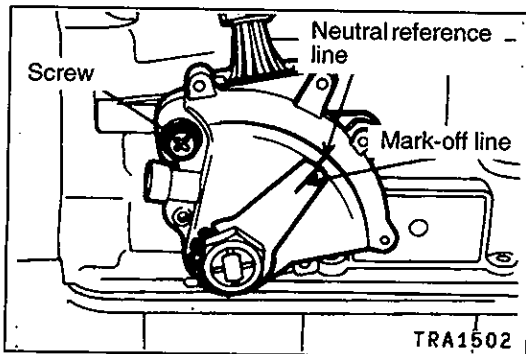

65. Align the neutral reference line on the inhibitor switch with the mark-off line on the neutral adjusting plate to adjust the neutral position.

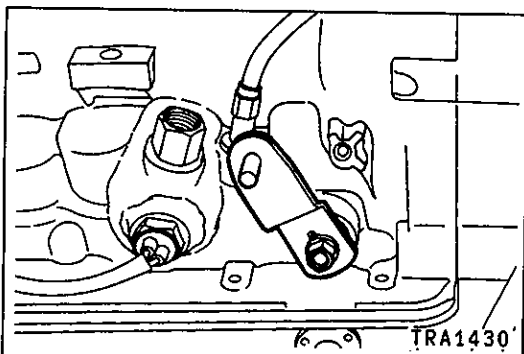

66. Attach the control lever.



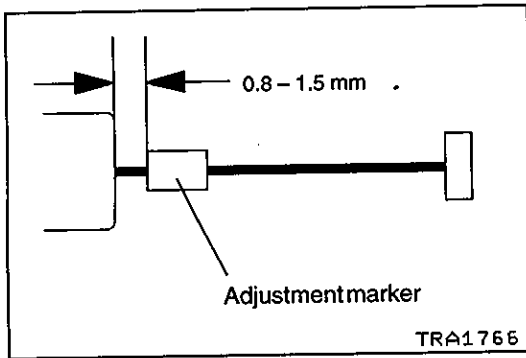

67. Bend the area around the center of the throttle cable to a radius of approximately 200 mm, pull the cable until there is no remaining play, and punch the adjustment marker at the illustrated position.

**Standard value: 0.8 – 1.5 mm**

68. Mount the transfer.

---

**NOTES**

# 4. OIL PUMP

## DISASSEMBLY AND REASSEMBLY

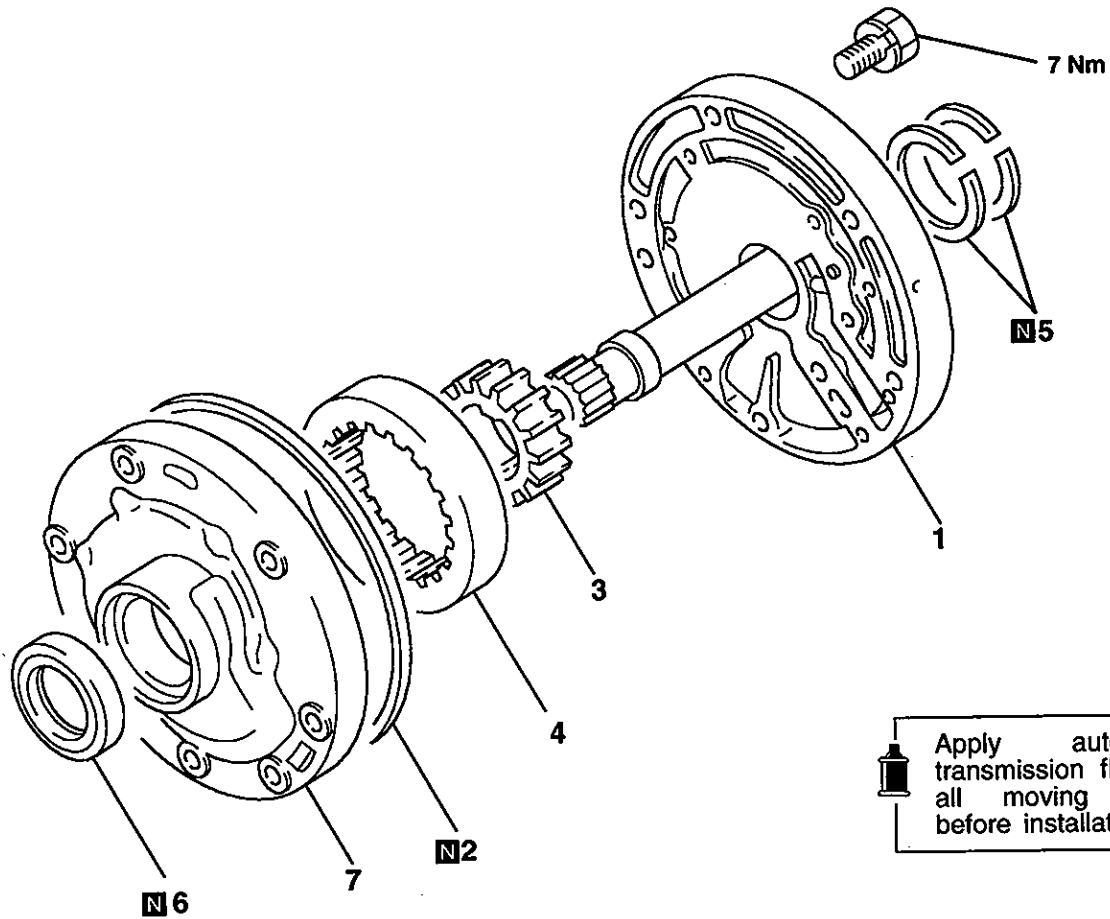

TRA1575

### Disassembly steps

- ▶C◀ 1. Stator support
- ▶B◀ 2. O-ring
- ◀A▶ ▶B◀ 3. Oil pump drive gear
- ◀A▶ ▶B◀ 4. Oil pump driven gear

- ▶A◀ 5. Seal ring
- ▶A◀ 6. Oil seal
- ▶A◀ 7. Oil pump body

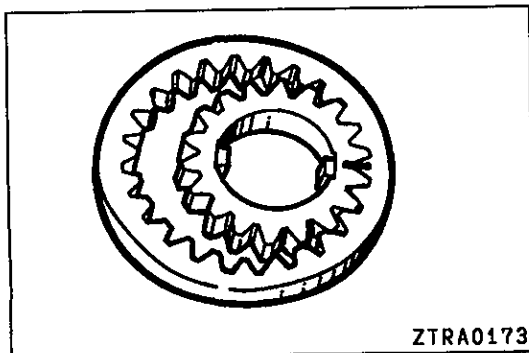

ZTRA0173

### DISASSEMBLY SERVICE POINT

#### ◀A▶ OIL PUMP DRIVE GEAR / OIL PUMP DRIVEN GEAR REMOVAL

- (1) In order that the gears can be reassembled with the correct orientations, apply mating marks to the side of each one.

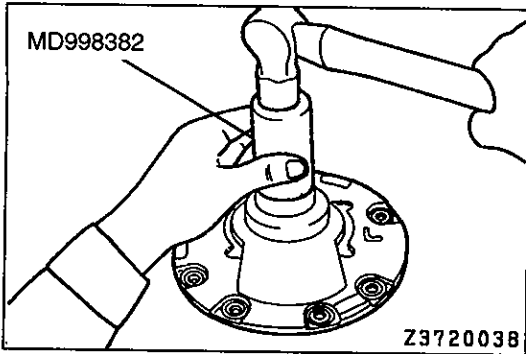

## REASSEMBLY SERVICE POINTS

### ▶A◀ OIL SEAL INSTALLATION

- (1) Use the indicated special tool to install the oil seal.

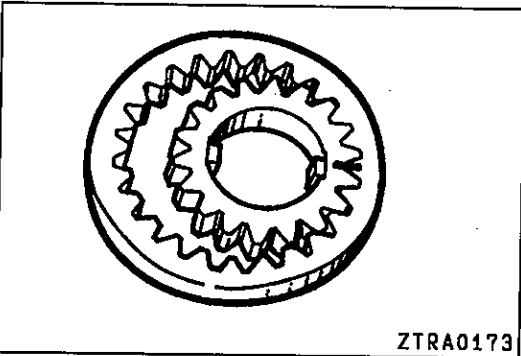

### ▶B◀ DRIVE GEAR / DRIVEN GEAR INSTALLATION

- (1) Reinstall the gears with the mating marks applied during disassembly in alignment.

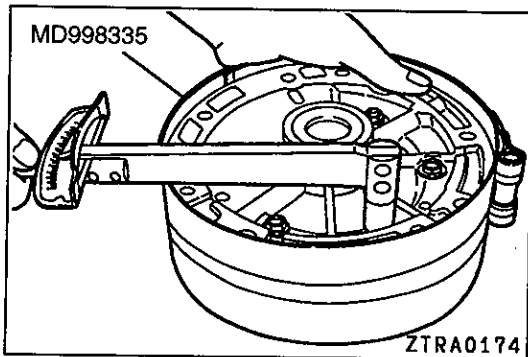

### ▶C◀ STATOR SUPPORT INSTALLATION

- (1) Assemble the oil pump body to the stator support; then fasten the bolts fingertight.
- (2) Clamp the oil pump cover and the stator support together using the indicated special tool; then tighten the bolts to the specified torque.

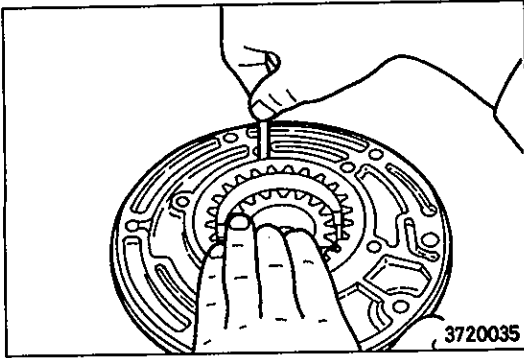

## INSPECTION

### DRIVE GEAR AND DRIVEN GEAR

#### Body clearance inspection

- (1) Pull the driven gear fully to one side; using a feeler gauge, measure the clearance that opens up on the opposing side between the driven gear and the oil pump body.

**Standard value: 0.07 – 0.15 mm**

**Limit value: 0.3 mm**

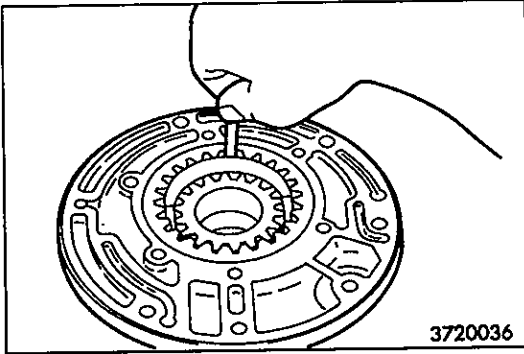

#### Tip clearance inspection

- (1) Measure the clearance between the crescent and the driven gear using a feeler gauge.

**Standard value: 0.11 – 0.14 mm**

**Limit value: 0.3 mm**

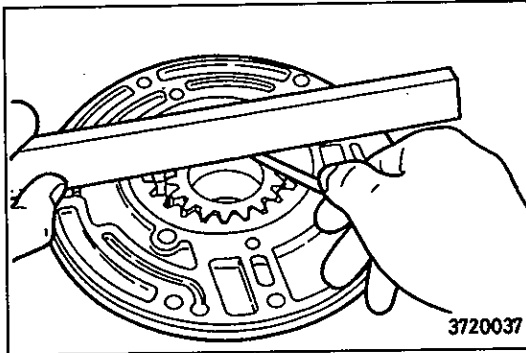

#### Side clearance inspection

- (1) Using a square and a feeler gauge, measure the clearance between the end face of the gears and that of the pump body on the stator shaft mounting side.

**Standard value: 0.02 – 0.05 mm**

**Limit value: 0.1 mm**

---

**NOTES**

# 5. OVERDRIVE CLUTCH

## DISASSEMBLY AND REASSEMBLY

Apply automatic transmission fluid to all moving parts before installation.

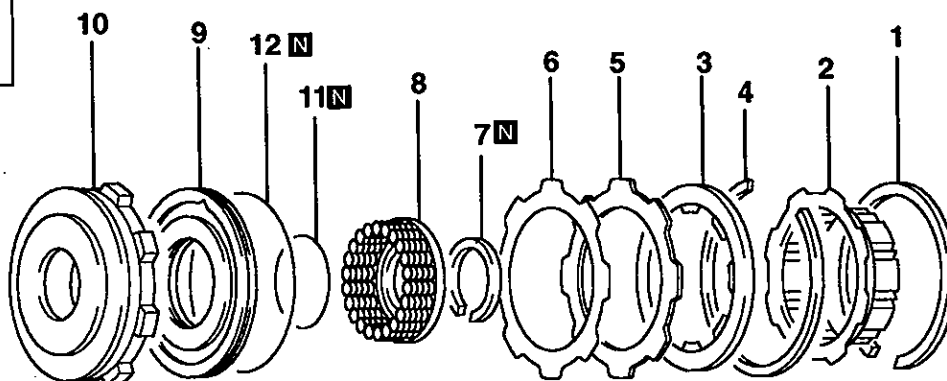

TRA1547

### Disassembly steps

- ▶D▶ 1. Snap ring
- ▶B▶ 2. Overdrive brake hub
- ▶C▶ 3. Clutch disc
- ▶B▶ 4. Snap ring
- ▶B▶ 5. Backing plate
- ▶B▶ 6. Cushion plate

- ◀A▶ ▶A▶ 7. Snap ring
- ◀B▶ 8. Return spring
- 9. Overdrive clutch piston
- 10. Overdrive clutch cylinder
- 11. O-ring
- 12. O-ring

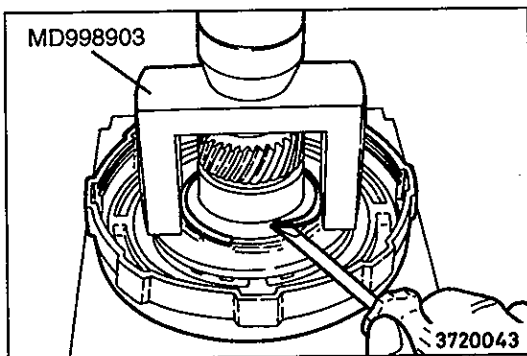

### DISASSEMBLY SERVICE POINTS

#### ◀A▶ SNAP RING REMOVAL

- (1) Compress the return spring using the indicated special tool and remove the snap ring.

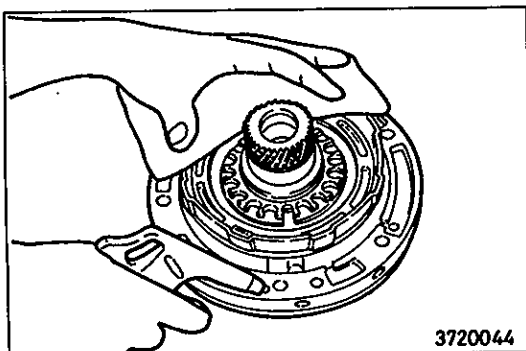

#### ◀B▶ OVERDRIVE CLUTCH PISTON REMOVAL

- (1) Attach the overdrive clutch to the oil pump; then blow air into the clutch to remove the overdrive piston.

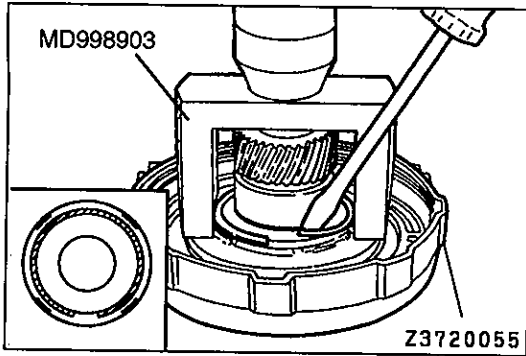

## REASSEMBLY SERVICE POINTS

### ▶A◀ SNAP RING INSTALLATION

- (1) Compress the return spring using the indicated special tool and attach the snap ring.

#### Caution

- Ensure that the end gap in the snap ring is not aligned with any of the spring retainer tabs.

### ▶B◀ CUSHION PLATE / BACKING PLATE / CLUTCH DISC INSTALLATION

- (1) Use compressed air to blow any excess automatic transmission fluid from the clutch disc.

#### Caution

- There is a danger that the disc may be damaged in this process: Do not bring the air gun any closer to the surface of the disc than necessary.

- (2) Attach the cushion plate, the backing plate, and the clutch disc.

- (3) Attach the overdrive clutch hub and the snap ring.

- (4) Attach the overdrive clutch cylinder to the oil pump. Then, blow in low pressure air (395 – 785 kPa) and inspect the stroke of the piston.

**Standard value: 1.74 – 2.44 mm**

If this standard value is exceeded, it will indicate possible wearing of the disc. Alternatively, if the stroke is less than the standard value, it will point to a possible mistake in assembly.

- (5) After the inspection of the stroke has been completed, remove the snap ring and the overdrive clutch hub.

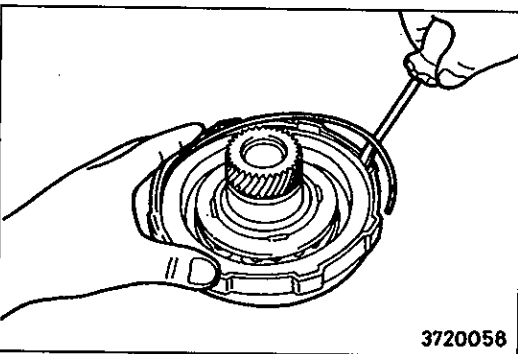
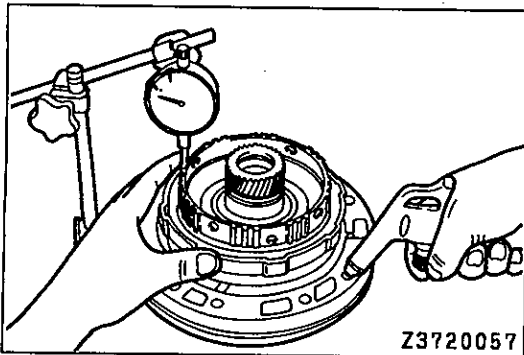
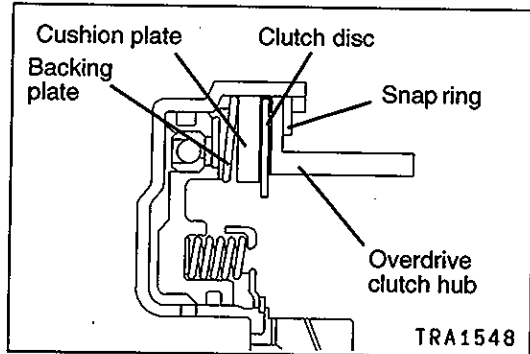

### ▶C◀ SNAP RING INSTALLATION

- (1) Insert the snap ring into the groove in the clutch cylinder.

#### Caution

- Ensure that the ends of the snap ring are not aligned with any of the recesses.

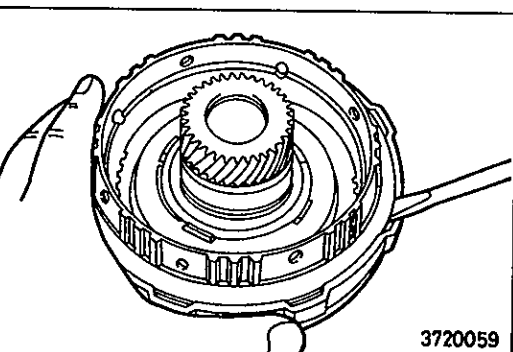

### ▶D◀ SNAP RING INSTALLATION

- (1) Insert the snap ring into the groove in the clutch cylinder.

#### Caution

- Ensure that the ends of the snap ring are not aligned with any of the recesses.

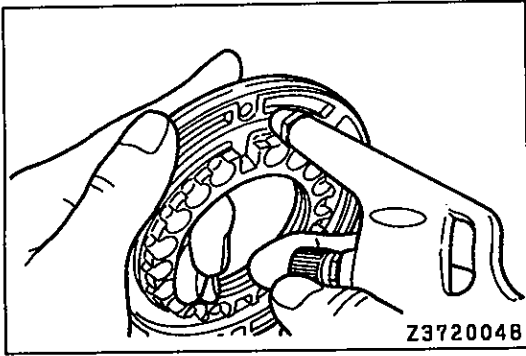

**INSPECTION****OVERDRIVE CLUTCH PISTON**

- (1) Shake the overdrive piston to confirm that the check ball can move freely.
- (2) Blow in air and confirm that there is no leakage from the valve.

---

**NOTES**

## 6. OVERDRIVE PLANETARY GEAR DISASSEMBLY AND REASSEMBLY

Apply automatic transmission fluid to all moving parts before installation.

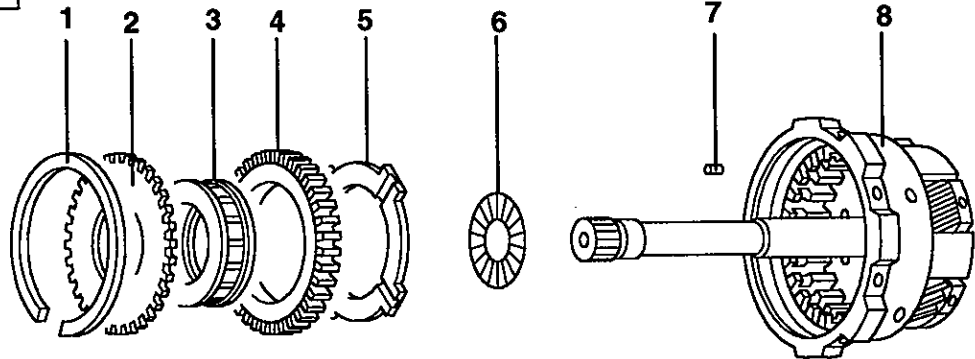

TRA1549

### Disassembly steps

- ▶B◀
1. Snap ring
  2. One-way clutch retainer
  3. One-way clutch
  4. One-way clutch outer race

- ▶A◀
5. Thrust washer
  6. Thrust bearing
  7. Pinion shaft plug
  8. Overdrive planetary carrier

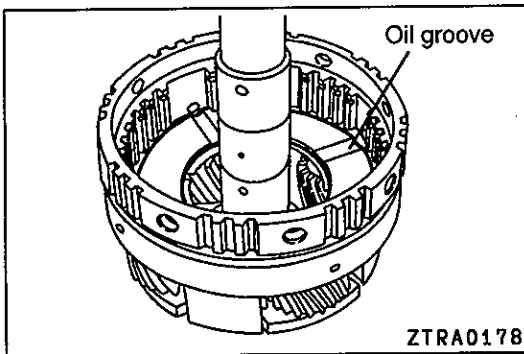

### REASSEMBLY SERVICE POINTS

#### ▶A◀ THRUST WASHER INSTALLATION

- (1) Install the thrust washer in such a way that its oil grooves are positioned as illustrated.

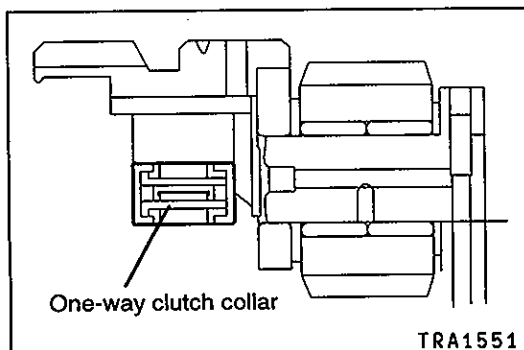

#### ▶B◀ ONE-WAY CLUTCH INSTALLATION

- (1) Install the one-way clutch in such a way that its collar is positioned as illustrated.

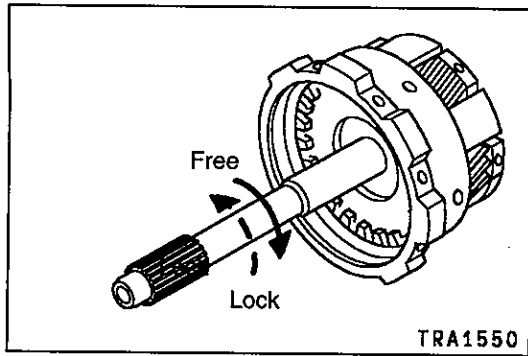

## INSPECTION

### ONE-WAY CLUTCH

- (1) While holding the overdrive planetary carrier firmly, rotate the input shaft. Confirm that the input shaft rotates smoothly in the clockwise direction and that it locks in the counterclockwise direction.

# 7. OVERDRIVE BRAKE

## DISASSEMBLY AND REASSEMBLY

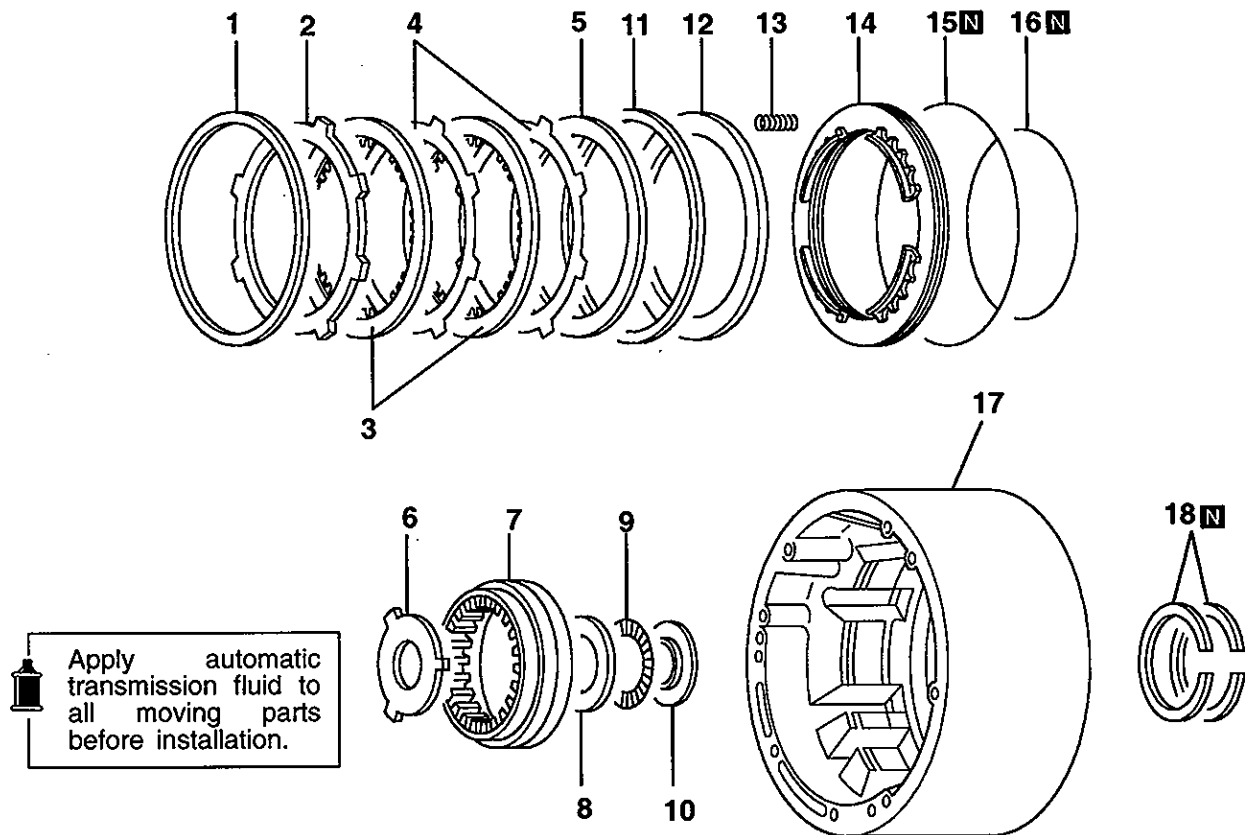

TRA1552

### Disassembly steps

- ▶D◀ 1. Snap ring
- ▶C◀ 2. Backing plate
- ▶C◀ 3. Brake discs
- ▶C◀ 4. Brake plates
- ▶C◀ 5. Cushion plate
- ▶B◀ 6. Thrust race
- ▶B◀ 7. Planetary ring gear
- ▶B◀ 8. Thrust bearing race
- ▶B◀ 9. Thrust bearing

- ▶B◀ 10. Thrust bearing race
- ▶A◀ 11. Snap ring
- ▶A◀ 12. Spring retainer
- ▶A◀ 13. Return spring
- ▶A◀ 14. Brake piston
- ▶A◀ 15. O-ring
- ▶A◀ 16. O-ring
- ▶A◀ 17. Overdrive case
- ▶A◀ 18. Seal ring

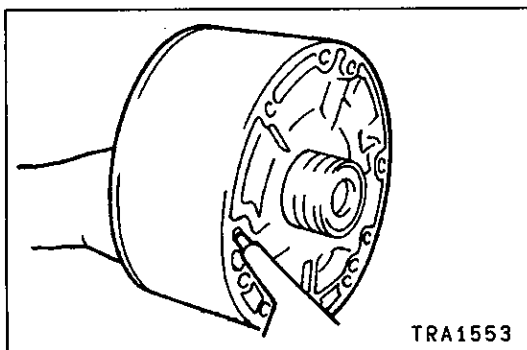

TRA1553

### DISASSEMBLY SERVICE POINT

#### ▶A◀ BRAKE PISTON REMOVAL

(1) Blow in air to remove the brake piston.

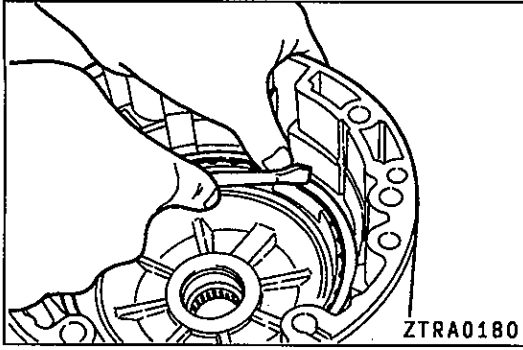

## REASSEMBLY SERVICE POINTS

### ▶A◀ SNAP RING INSTALLATION

- (1) Insert the snap ring.

#### Caution

- Ensure that the ends of the snap ring are not aligned with any of the recesses in the case.

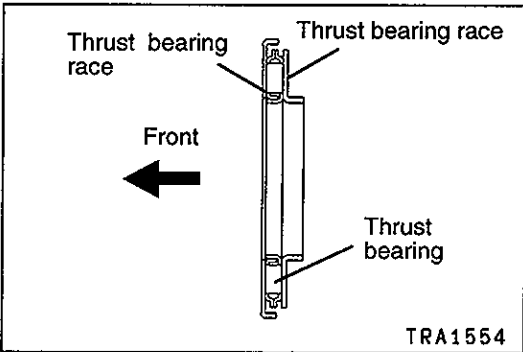

### ▶B◀ THRUST BEARING / THRUST BEARING RACES INSTALLATION

- (1) Assemble the thrust bearing and the two thrust bearing races in such a way that they are oriented as illustrated. Then, install the assembly into the overdrive case.

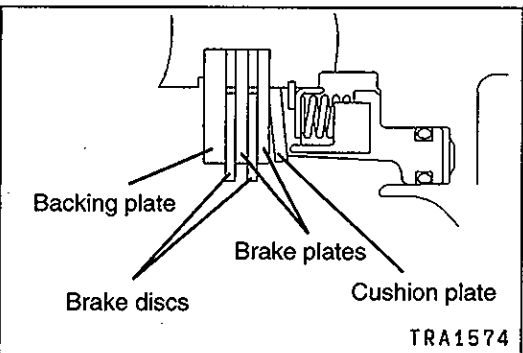

### ▶C◀ CUSHION PLATE / BRAKE PLATES / BRAKE DISCS / BACKING PLATE INSTALLATION

- (1) Use compressed air to blow any excess automatic transmission fluid from the brake discs.

#### Caution

- There is a danger that a disc may be damaged in this process: Do not bring the air gun any closer to the surface of the disc than necessary.
- (2) Attach the cushion plate, brake plates, brake discs, and backing plate.

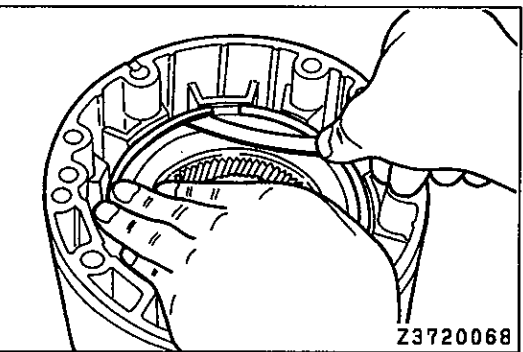

### ▶D◀ SNAP RING INSTALLATION

- (1) Insert the snap ring into the groove in the overdrive case.

#### Caution

- Ensure that the ends of the snap ring are not aligned with any of the recesses in the case.
- (2) Measure the clearance between the snap ring and the backing plate using a feeler gauge to inspect the stroke of the overdrive brake piston.

**Standard value: 0.56 – 1.62 mm**

If this standard value is exceeded, it will indicate possible wearing of the disc. Alternatively, if the stroke is less than the standard value, it will point to a possible mistake in assembly.

# 8. DIRECT CLUTCH

## DISASSEMBLY AND REASSEMBLY

Apply automatic transmission fluid to all moving parts before installation.

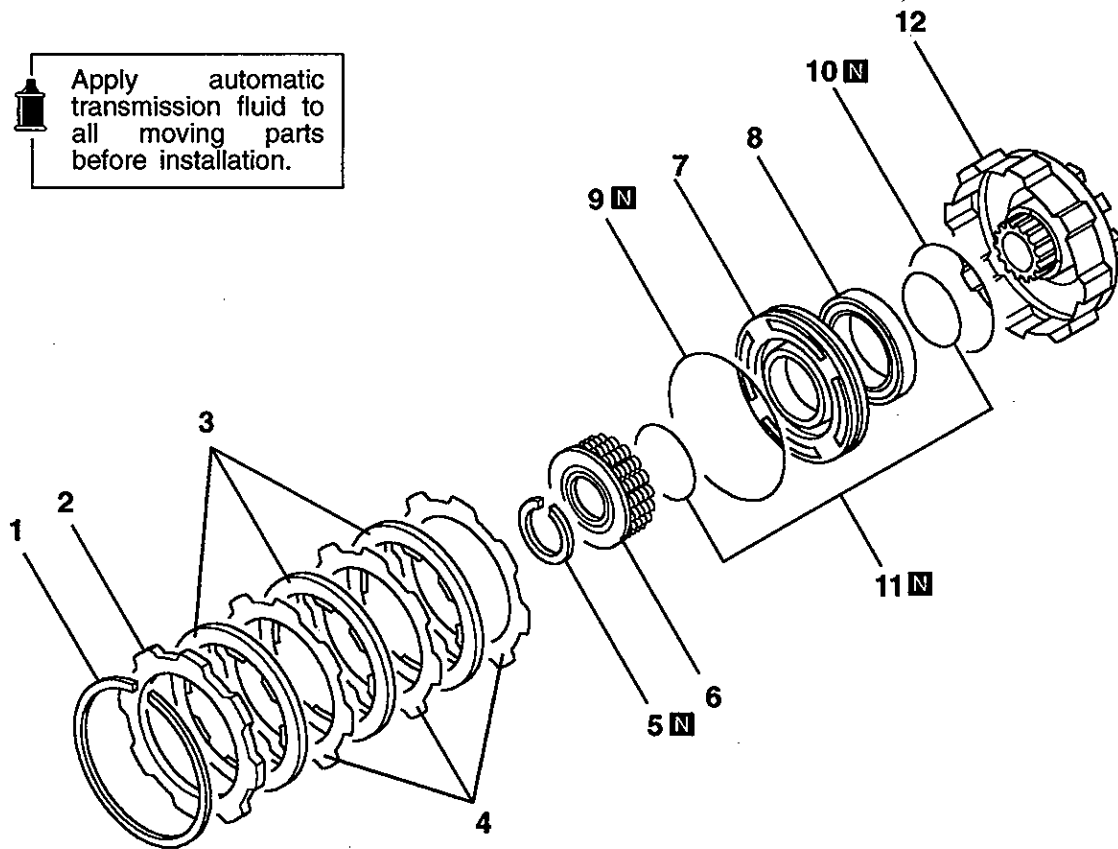

TRA1559

### Disassembly steps

- ◀B▶ 1. Snap ring
- ◀B▶ 2. Backing plate
- ◀B▶ 3. Clutch discs
- ◀B▶ 4. Clutch plates
- ◀A▶ 5. Snap ring
- ◀A▶ 6. Spring retainer

- ◀B▶ 7. Direct clutch outer piston
- 8. Direct clutch inner piston
- 9. O-ring
- 10. O-ring
- 11. O-ring
- 12. Direct clutch cylinder

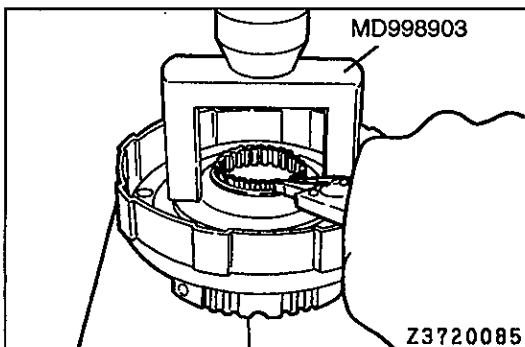

### DISASSEMBLY SERVICE POINTS

#### ◀A▶ SNAP RING REMOVAL

- (1) Compress the return spring using the indicated special tool and remove the snap ring.

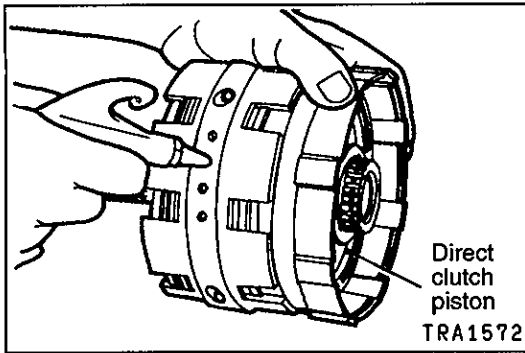

### ◀B▶ DIRECT CLUTCH PISTON REMOVAL

- (1) Attach the direct clutch cylinder to the center support.
- (2) Blow air into the cylinder to remove the direct clutch piston.

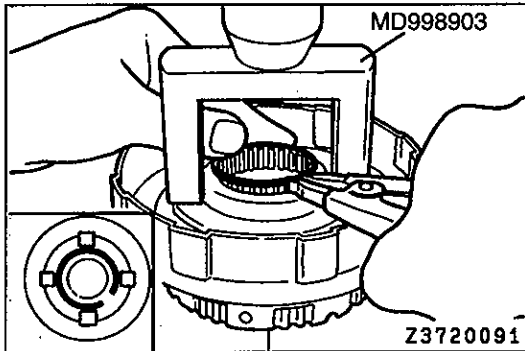

### REASSEMBLY SERVICE POINTS

#### ▶A▶ SNAP RING INSTALLATION

- (1) Compress the return spring using the indicated special tool and attach the snap ring.

#### Caution

- Ensure that the end gap in the snap ring is not aligned with any of the spring retainer lugs.

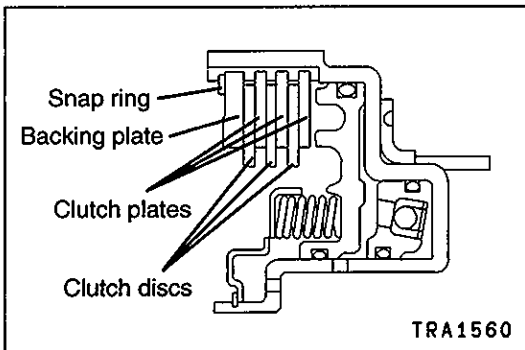

#### ▶B▶ CLUTCH PLATES / CLUTCH DISCS / BACKING PLATE / SNAP RING INSTALLATION

- (1) Use compressed air to blow any excess automatic transmission fluid from the clutch discs.

#### Caution

- There is a danger that a disc may be damaged in this process: Do not bring the air gun any closer to the surface of the disc than necessary.

- (2) Attach the clutch plates, clutch discs, backing plate; then attach the snap ring.
- (3) Attach the direct clutch to the center support. Then, blow in low pressure air (395 – 785 kPa) in a continued fashion and inspect the stroke of the piston.

**Standard value: 0.90 – 1.30 mm**

#### When reinstalling previously used parts:

If this standard value is exceeded, it will indicate possible wearing of the disc. Alternatively, if the stroke is less than the standard value, it will point to a possible mistake in assembly.

#### When installing new parts:

Select a clutch plate (thickness: 3.55 mm, 3.75 mm, or 4.00 mm) and adjust to give the standard value.

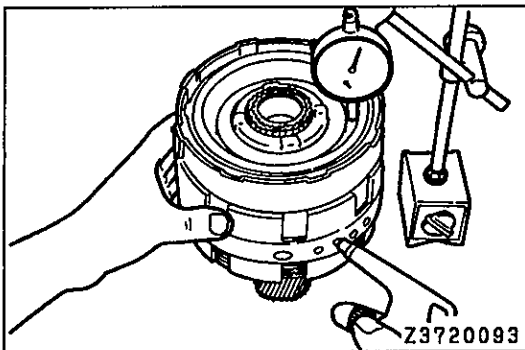



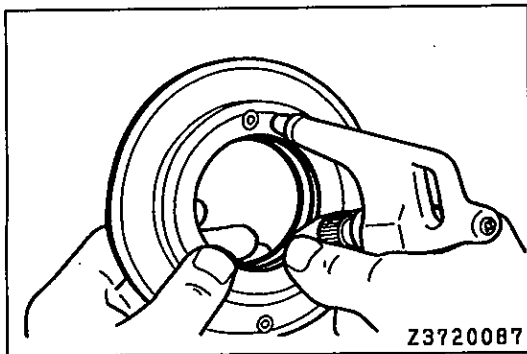

## INSPECTION

### DIRECT CLUTCH PISTON

- (1) Shake the direct clutch piston to confirm that the check ball can move freely.
- (2) Blow in air and confirm that there is no leakage from the valve.

---

**NOTES**

# 9. FORWARD CLUTCH DISASSEMBLY AND REASSEMBLY

Apply automatic transmission fluid to all moving parts before installation.

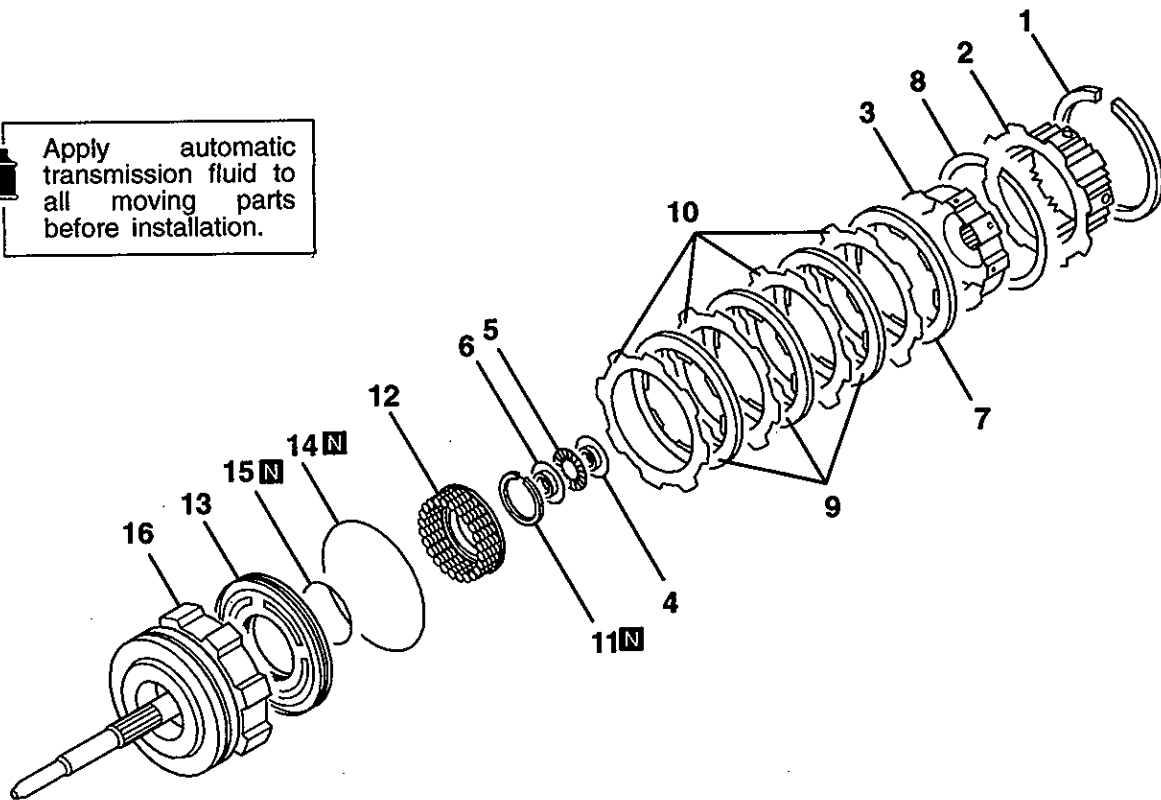

TRA1555

### Disassembly steps

- |     |                        |     |                             |
|-----|------------------------|-----|-----------------------------|
| ◀D▶ | 1. Snap ring           | ▶B▶ | 9. Clutch discs             |
|     | 2. Direct clutch hub   | ▶B▶ | 10. Clutch plates           |
|     | 3. Forward clutch hub  | ▶A▶ | 11. Snap ring               |
|     | 4. Thrust bearing race |     | 12. Return spring           |
|     | 5. Thrust bearing      | ▶B▶ | 13. Forward clutch piston   |
|     | 6. Thrust bearing race |     | 14. O-ring                  |
| ▶B▶ | 7. Clutch disc         |     | 15. O-ring                  |
| ▶C▶ | 8. Snap ring           |     | 16. Forward clutch cylinder |

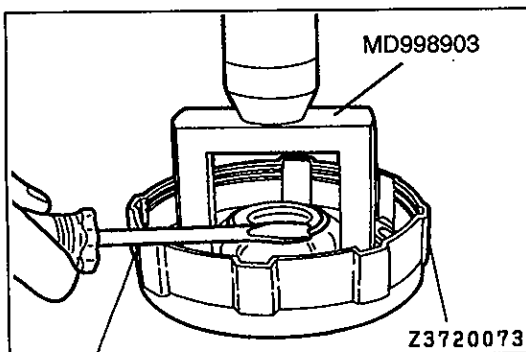

### DISASSEMBLY SERVICE POINTS

#### ◀A▶ SNAP RING REMOVAL

- (1) Compress the return spring using the indicated special tool and remove the snap ring.

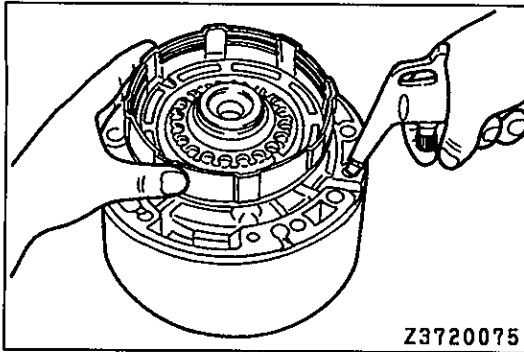

### ◀B▶ FORWARD CLUTCH PISTON REMOVAL

- (1) Attach the forward clutch cylinder to the overdrive case.
- (2) Blow air into the cylinder to remove the forward clutch piston.

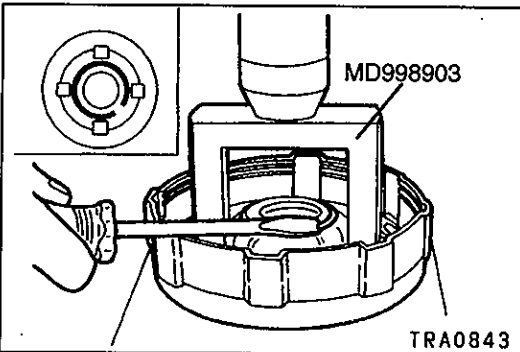

### REASSEMBLY SERVICE POINTS

#### ▶A◀ SNAP RING INSTALLATION

- (1) Compress the return spring using the indicated special tool and attach the snap ring.

#### Caution

- Ensure that the end gap in the snap ring is not aligned with any of the spring retainer lugs.

#### ▶B◀ CLUTCH PLATES / CLUTCH DISCS INSTALLATION

- (1) Use compressed air to blow any excess automatic transmission fluid from the clutch discs.

#### Caution

- There is a danger that a disc may be damaged in this process: Do not bring the air gun any closer to the surface of the disc than necessary.

- (2) Assemble the clutch plates and the clutch discs alternately in the cylinder; then attach the direct clutch hub and the snap ring.

- (3) Attach the forward clutch cylinder to the overdrive case. Then, blow in low pressure air (395 – 785 kPa) in a continued fashion and inspect the stroke of the piston.

**Standard value: 1.74 – 2.44 mm**

#### When reinstalling previously used parts:

If this standard value is exceeded, it will indicate possible wearing of the disc. Alternatively, if the stroke is less than the standard value, it will point to a possible mistake in assembly.

#### When installing new parts:

Select a clutch plate (thickness: 1.8 mm or 2.0mm) and adjust to give the standard value.

- (4) After the inspection of the stroke has been completed, remove the snap ring and the direct clutch hub.

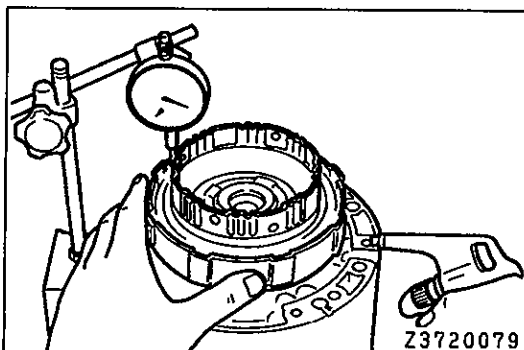
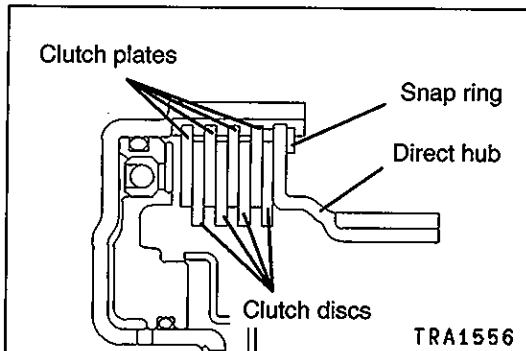

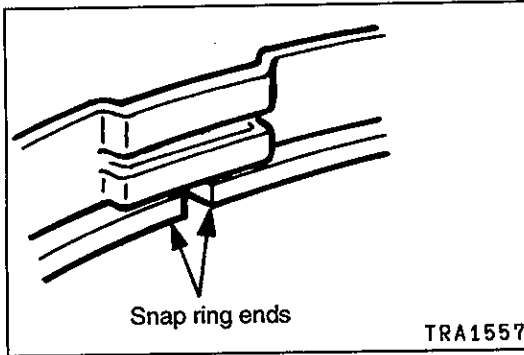

### ▶C◀ SNAP RING INSTALLATION

- (1) Insert the snap ring.

#### Caution

- Ensure that the ends of the snap ring are not aligned with any of the recesses.

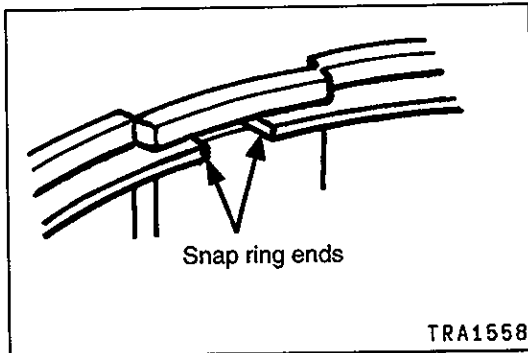

### ▶D◀ SNAP RING INSTALLATION

- (1) Insert the snap ring.

#### Caution

- Ensure that the ends of the snap ring are not aligned with any of the recesses.

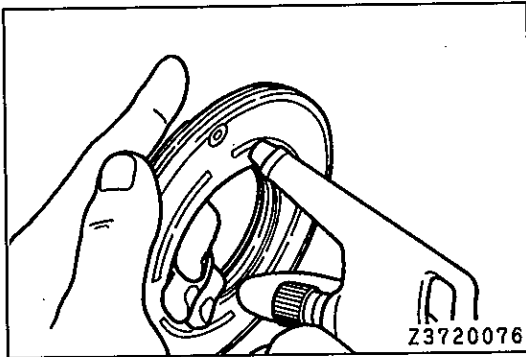

## INSPECTION

### FORWARD CLUTCH PISTON

- (1) Shake the overdrive piston to confirm that the check ball can move freely.
- (2) Blow in air and confirm that there is no leakage from the valve.

---

**NOTES**

# 10. CENTER SUPPORT DISASSEMBLY AND REASSEMBLY

Apply automatic transmission fluid to all moving parts before installation.

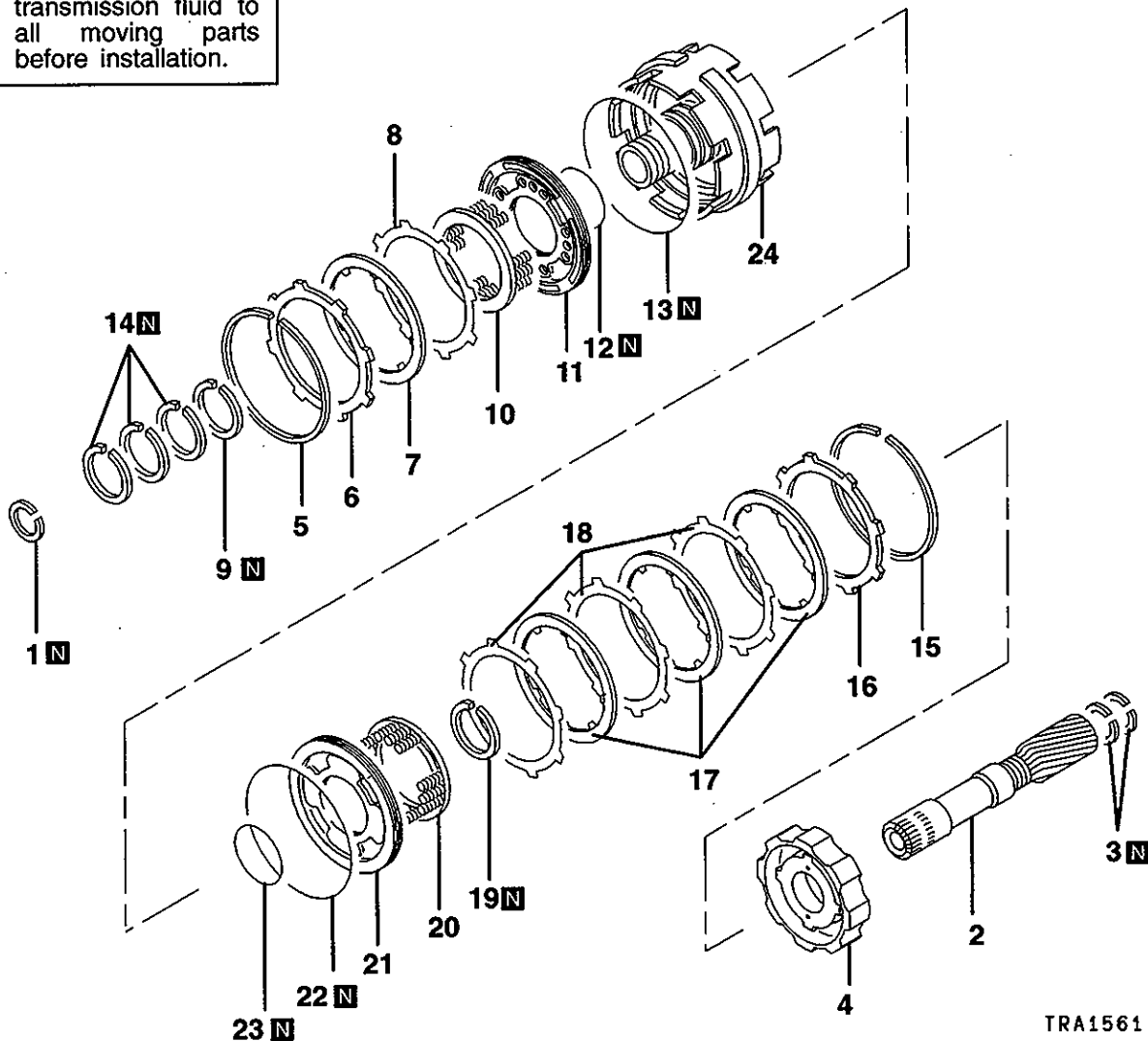

TRA1561

### Disassembly steps

- |  |                             |  |                       |
|--|-----------------------------|--|-----------------------|
|  | 1. Snap ring                |  | 13. O-ring            |
|  | 2. Planetary sun gear shaft |  | 14. Seal rings        |
|  | 3. Seal ring                |  | 15. Snap ring         |
|  | 4. No.2 brake hub           |  | 16. Backing plate     |
|  | 5. Snap ring                |  | 17. Brake discs       |
|  | 6. Backing plate            |  | 18. Brake plates      |
|  | 7. Brake disc               |  | 19. Snap ring         |
|  | 8. Brake plate              |  | 20. Return spring     |
|  | 9. Snap ring                |  | 21. No.2 brake piston |
|  | 10. Return spring           |  | 22. O-ring            |
|  | 11. No.1 brake piston       |  | 23. O-ring            |
|  | 12. O-ring                  |  | 24. Center support    |

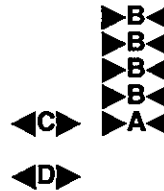
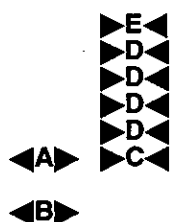

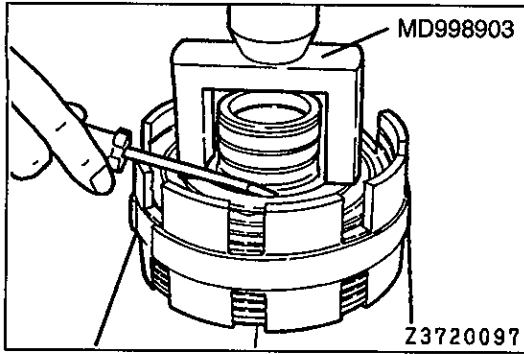
**DISASSEMBLY SERVICE POINTS****◀A▶ SNAP RING REMOVAL**

- (1) Compress the return spring using the indicated special tool and remove the snap ring.

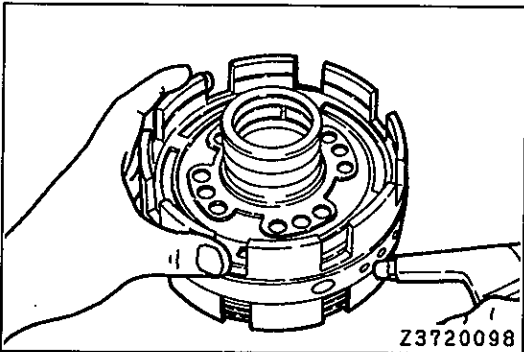
**◀B▶ NO.1 BRAKE PISTON REMOVAL**

- (1) Blow in low pressure air to remove the piston.

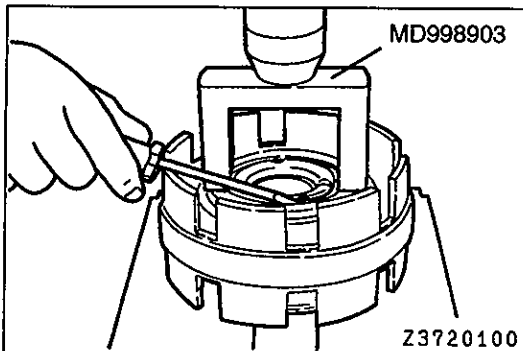
**◀C▶ SNAP RING REMOVAL**

- (1) Compress the return spring using the indicated special tool and remove the snap ring.

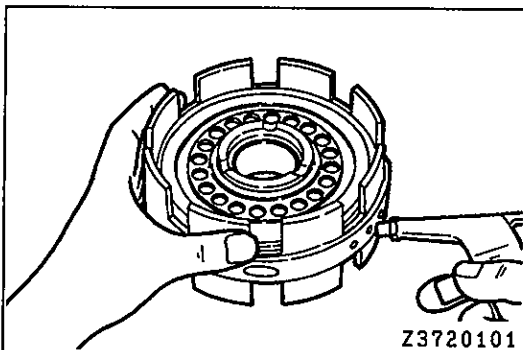
**◀D▶ NO.2 BRAKE PISTON REMOVAL**

- (1) Blow in low pressure air to remove the piston.

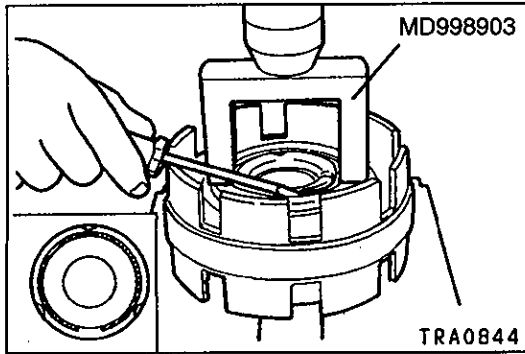

**REASSEMBLY SERVICE POINTS****▶A◀ SNAP RING INSTALLATION**

- (1) Compress the return spring using the indicated special tool and attach the snap ring.

**Caution**

- Ensure that the end gap in the snap ring is not aligned with any of the spring retainer lugs.

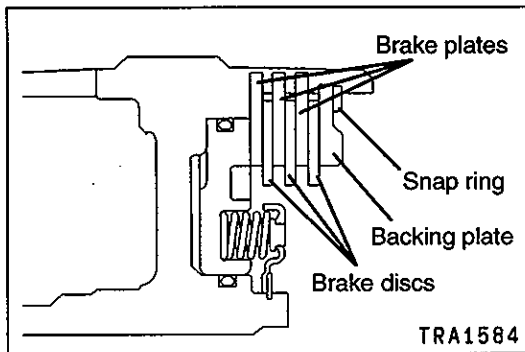
**▶B◀ BRAKE PLATES / BRAKE DISCS / BACKING PLATE / SNAP RING INSTALLATION**

- (1) Use compressed air to blow any excess automatic transmission fluid from the brake discs.

**Caution**

- There is a danger that a disc may be damaged in this process: Do not bring the air gun any closer to the surface of the disc than necessary.

- (2) Attach the brake plates, brake discs, backing plate; then attach the snap ring.
- (3) Blow in low pressure air (395 – 785 kPa) in a continued fashion and inspect the piston stroke for the No.2 brake.

**Standard value: 1.03 – 1.65 mm**

If this standard value is exceeded, it will indicate possible wearing of the disc. Alternatively, if the stroke is less than the standard value, it will point to a possible mistake in assembly.

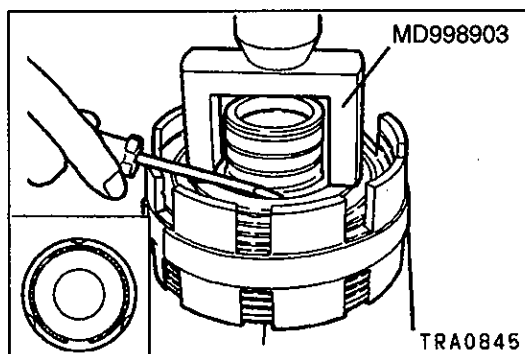
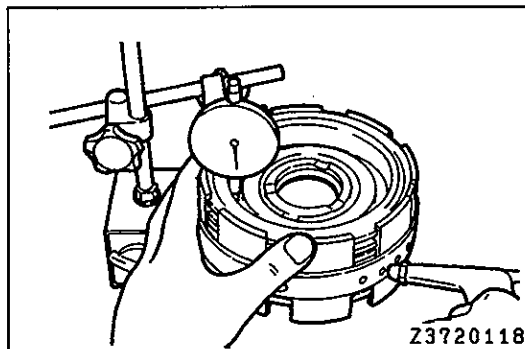
**▶C◀ SNAP RING INSTALLATION**

- (1) Compress the return spring using the indicated special tool and attach the snap ring.

**Caution**

- Ensure that the end gap in the snap ring is not aligned with any of the spring retainer lugs.

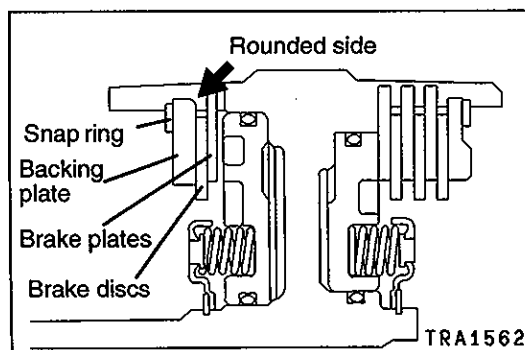
**▶D◀ BRAKE PLATES / BRAKE DISCS / BACKING PLATE / SNAP RING INSTALLATION**

- (1) Use compressed air to blow any excess automatic transmission fluid from the brake disc.

**Caution**

- There is a danger that the disc may be damaged in this process: Do not bring the air gun any closer to the surface of the disc than necessary.

- (2) Attach the brake plate, brake disc, backing plate; then attach the snap ring.

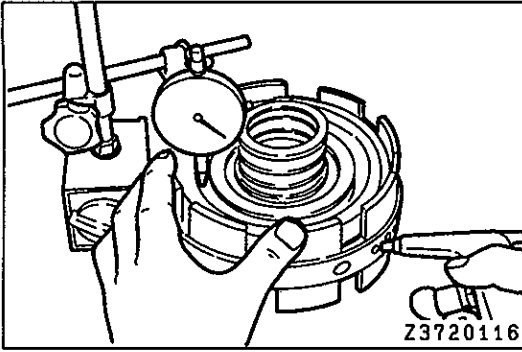

- (3) Blow in low pressure air (395 – 785 kPa) in a continued fashion and inspect the piston stroke for the No.1 brake.

**Standard value: 0.78 – 1.32 mm**

If this standard value is exceeded, it will indicate possible wearing of the disc. Alternatively, if the stroke is less than the standard value, it will point to a possible mistake in assembly.

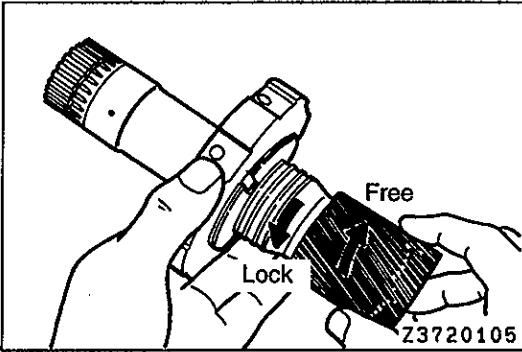

### ►E◄ NO.2 BRAKE HUB INSTALLATION

- (1) Attach the No.2 brake hub to the sun gear shaft. While holding the No.2 brake hub firmly, rotate the sun gear shaft to check if it rotates smoothly in the clockwise direction and locks in the counterclockwise direction.

# 11. FRONT PLANETARY GEAR

## DISASSEMBLY AND REASSEMBLY

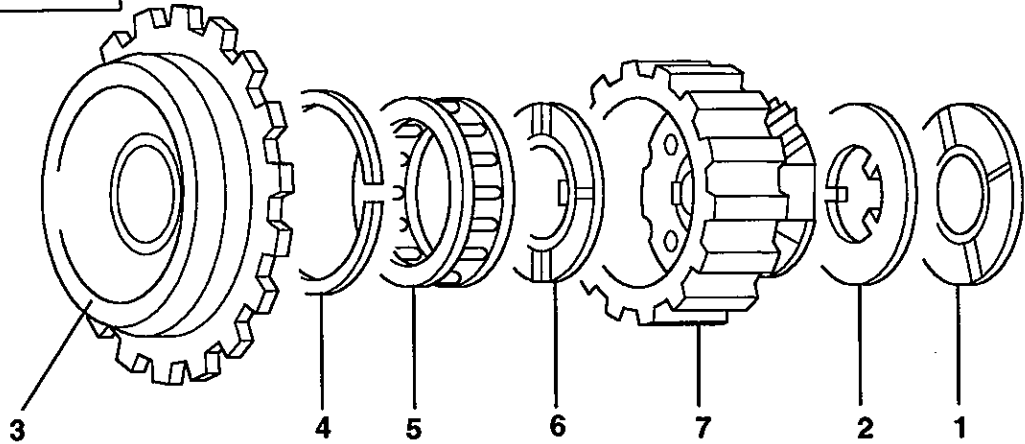

 Apply automatic transmission fluid to all moving parts before installation.



TRA1563

### Disassembly steps

1. Thrust washer
2. Thrust washer
3. One-way clutch inner race
4. Retaining ring

-  5. One-way clutch  
 6. Thrust washer  
 7. Front planetary gear

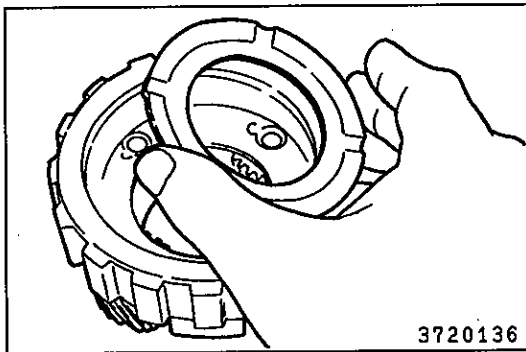

### REASSEMBLY SERVICE POINTS

#### ▶A◀ THRUST WASHER INSTALLATION

- (1) Install the thrust washer in such a way that its oil grooves are aligned with the oil holes in the planetary gear.

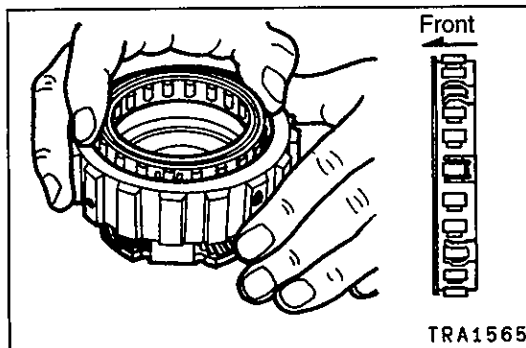

#### ▶B◀ ONE-WAY CLUTCH INSTALLATION

- (1) Install the one-way clutch in the illustrated direction.

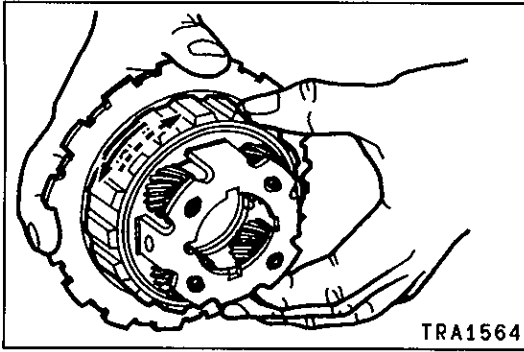

## INSPECTION

### ONE-WAY CLUTCH

- (1) Firmly hold the inner race by hand and turn the front planetary gear in either direction. Check to ensure that it rotates smoothly in the counterclockwise direction and that it locks in the clockwise direction.

# 12. REAR PLANETARY GEAR AND OUTPUT SHAFT DISASSEMBLY AND REASSEMBLY

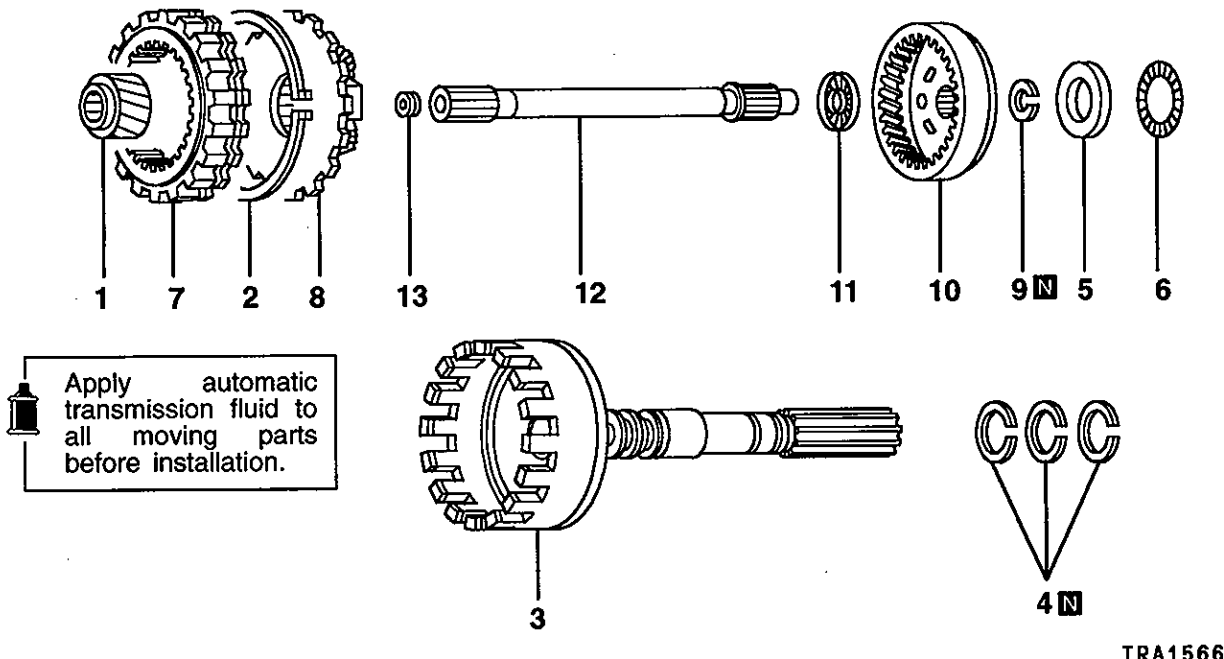

### Disassembly steps

- ▶A◀
1. Planetary sun gear
  2. Snap rings
  3. Output shaft
  4. Seal ring
  5. Thrust bearing race
  6. Thrust bearing
  7. Front planetary ring gear

8. Rear planetary gear
9. Snap ring
10. Rear planetary ring gear
11. Thrust bearing
12. Intermediate shaft
13. O-ring

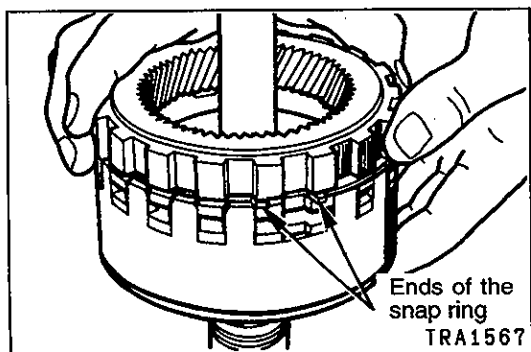

### REASSEMBLY SERVICE POINT

#### ▶A◀ SNAP RING INSTALLATION

- (1) Attach the snap ring to the front planetary ring gear.
- (2) Place the front planetary ring gear on the drum of the output shaft and align the ends of the snap ring with the wide inter-tooth section.
- (3) Push down the front planetary ring gear to install the snap ring into the groove.

---

**NOTES**

# 13. NO.3 BRAKE PISTON DISASSEMBLY AND REASSEMBLY

 Apply automatic transmission fluid to all moving parts before installation.

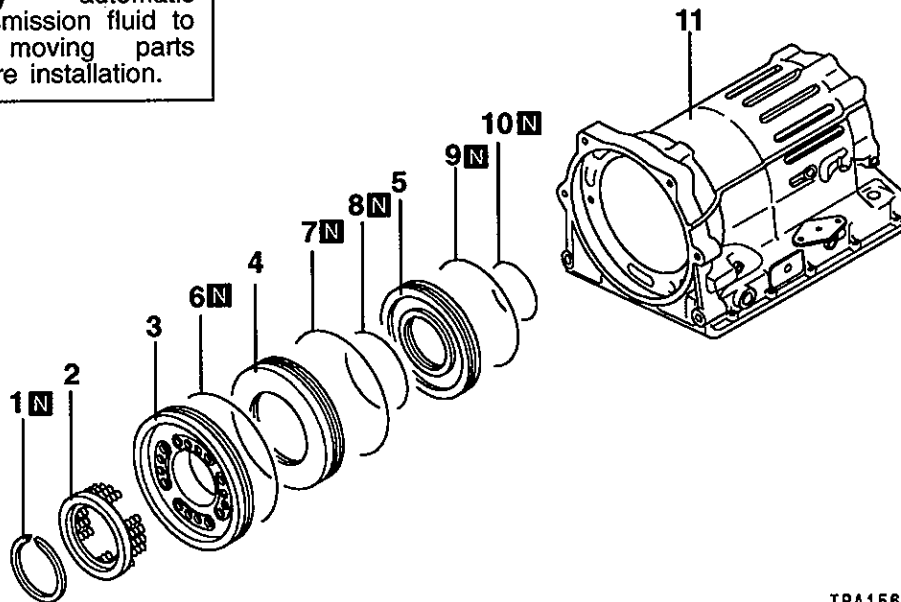

TRA1588

### Disassembly steps

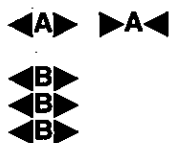

- 1. Snap ring
- 2. Return spring
- 3. No. 3 brake primary piston
- 4. Reaction sleeve
- 5. No. 3 brake secondary piston
- 6. O-ring
- 7. O-ring
- 8. O-ring
- 9. O-ring
- 10. O-ring
- 11. Transmission case

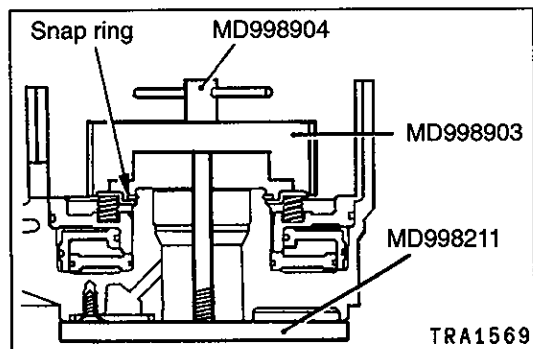

### DISASSEMBLY SERVICE POINTS

#### ◀A▶ SNAP RING REMOVAL

- (1) Compress the return spring using the indicated special tool and remove the snap ring.

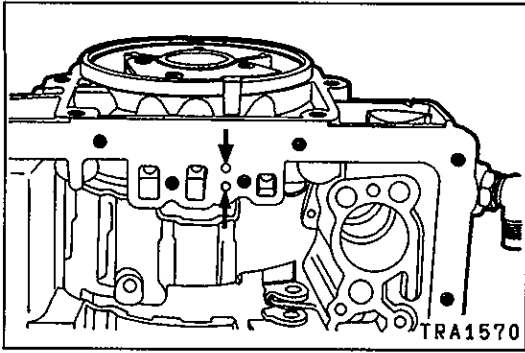

### ◀B▶ NO.3 BRAKE PRIMARY PISTON / REACTION SLEEVE / NO.3 BRAKE SECONDARY PISTON REMOVAL

- (1) Place the transmission case on the work surface with the front side facing downward. In order that the No.3 brake primary piston, reaction sleeve, and No.3 brake secondary piston are not damaged during this operation, several clean rags should be laid on this surface in advance.
- (2) Blow air into both of the indicated oil holes to remove the No.3 brake primary piston, reaction sleeve, and No.3 brake secondary piston.

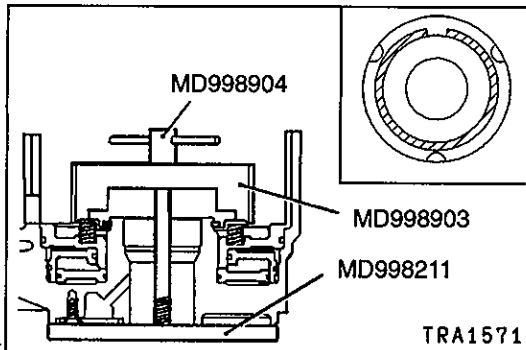

### REASSEMBLY SERVICE POINT

#### ▶A◀ SNAP RING INSTALLATION

- (1) Compress the return spring using the indicated special tool and attach the snap ring.

#### Caution

- Ensure that the end gap in the snap ring is not aligned with any of the spring retainer lugs.



## 14. VALVE BODY

### DISASSEMBLY AND REASSEMBLY

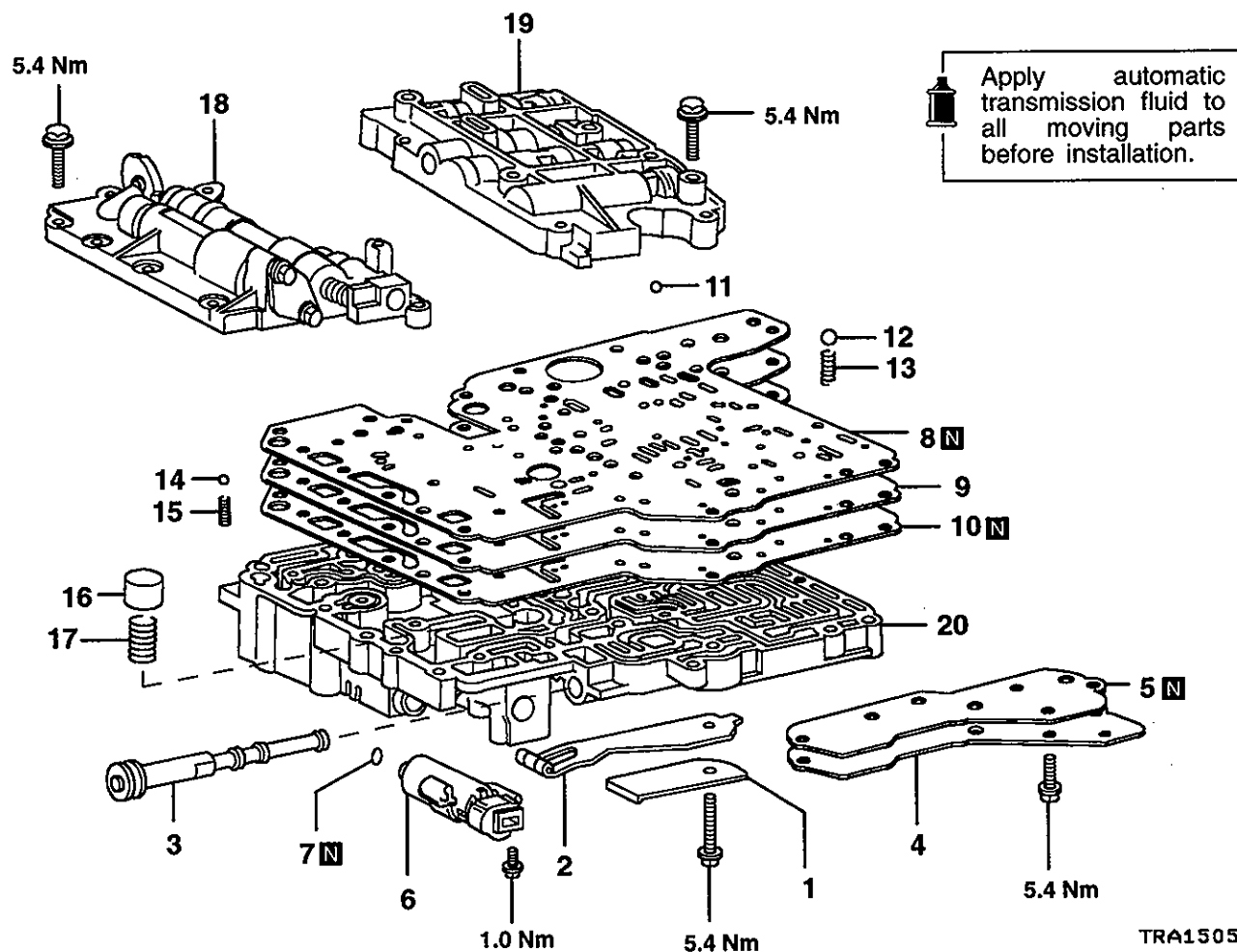

1. Manual detent spring cover
2. Manual detent spring
3. Manual valve
4. Valve body cover
5. Gasket
6. Solenoid valve
7. O-ring
8. Upper valve body gasket
9. Plate
10. Lower valve body gasket

11. Check ball
12. Check ball
13. Spring
14. Damping ball
15. Spring
16. Oil cooler bypass valve
17. Spring
18. Front upper valve body
19. Rear upper valve body
20. Lower valve body

TRA1505

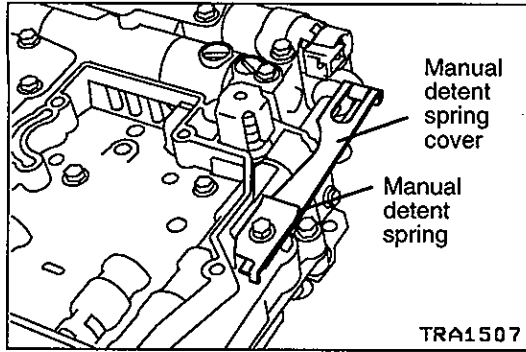
**DISASSEMBLY**

- (1) Remove both the manual detent spring cover and the manual detent spring.

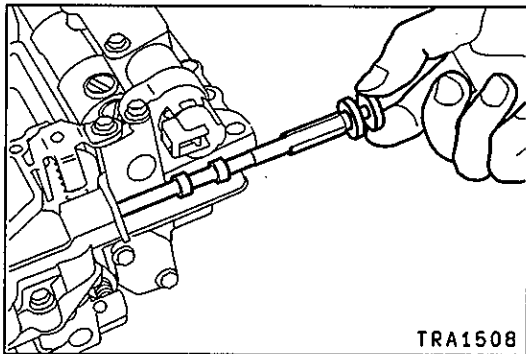

- (2) Remove the manual valve.

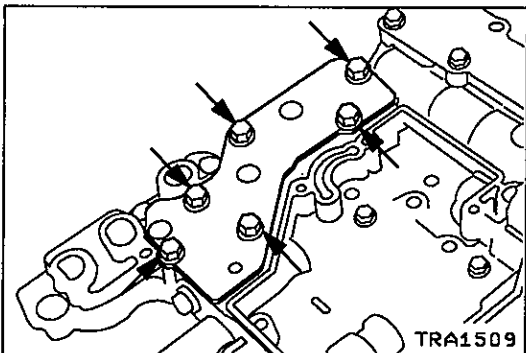

- (3) Remove the bolts indicated in the illustration; then remove the valve body cover and the gasket.

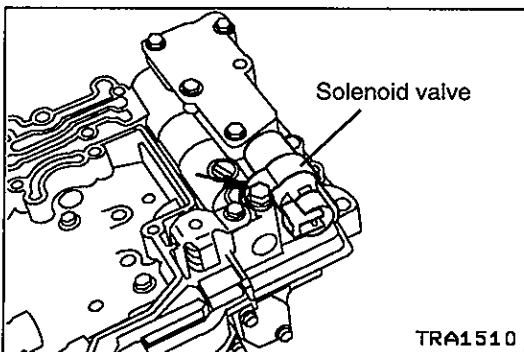

- (4) Unscrew the bolt arrowed in the illustration and remove the solenoid valve.
- (5) Remove the O-ring from the solenoid valve.

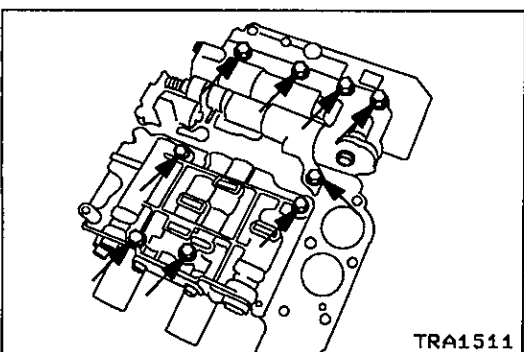

- (6) Remove the arrowed bolts from the upper valve body.

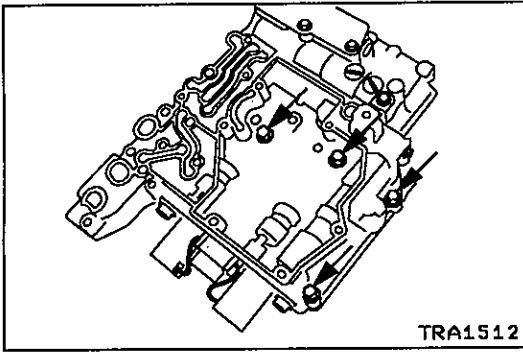

(7) Remove the arrowed bolts from the lower valve body.

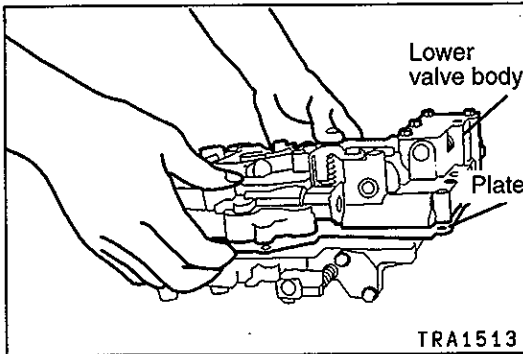

(8) While pushing the gaskets and the plate against lower valve body, disconnect the lower valve body from the upper valve body.

(9) Place down the lower valve body with the gasket and plate mounting side facing upward.

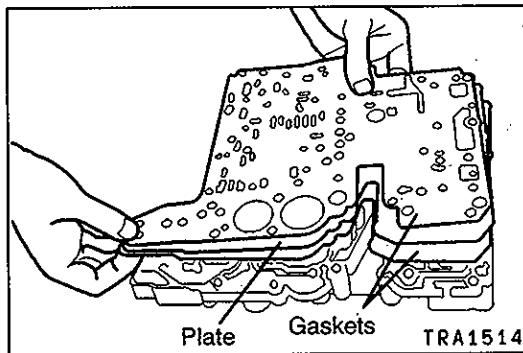

(10) Remove the two valve body gaskets and the plate.

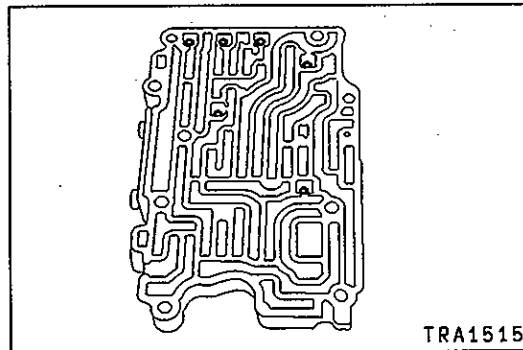

(11) Remove the six check balls from the rear upper valve body.

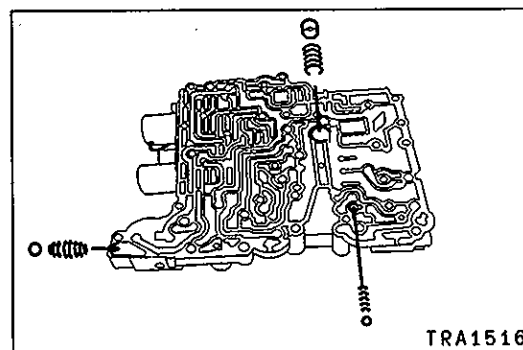

(12) Remove the check ball, the damping ball, the oil cooler bypass valve and their springs from the lower valve body.

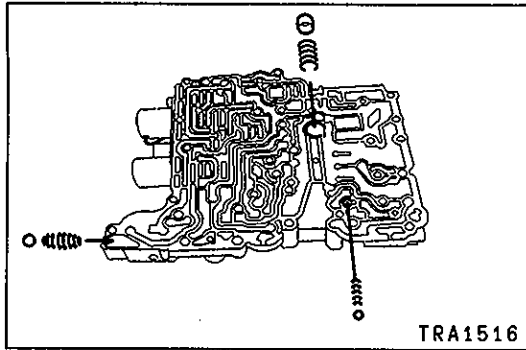

## REASSEMBLY

- (1) Insert the check ball, the damping ball, the oil cooler bypass valve and their springs into the lower valve body as illustrated.

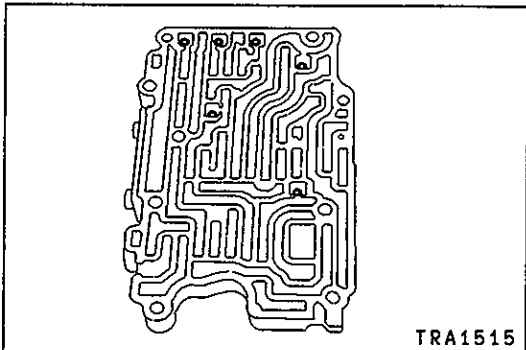

- (2) Insert the six check balls into the rear upper valve body at the indicated positions.

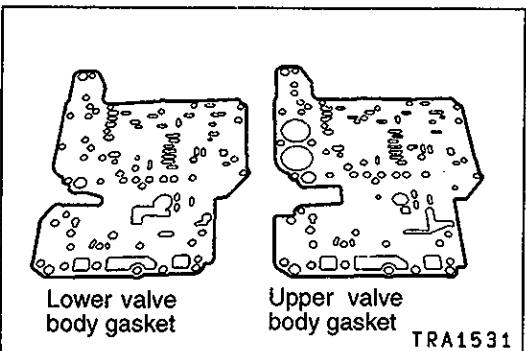

- (3) Lay a new lower valve body gasket and the plate on the lower valve body.

### Caution

- The upper valve body gasket and the lower valve body gasket differ in shape: Take care not to mistake either of these components with each other.

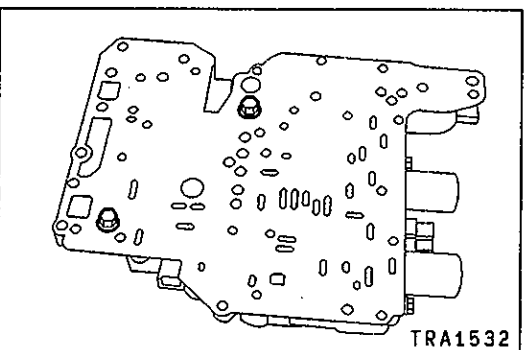

- (4) Secure the plate to the lower valve body temporarily by screwing suitable bolts at the illustrated positions.
- (5) Lay a new upper valve body gasket on the lower valve body.

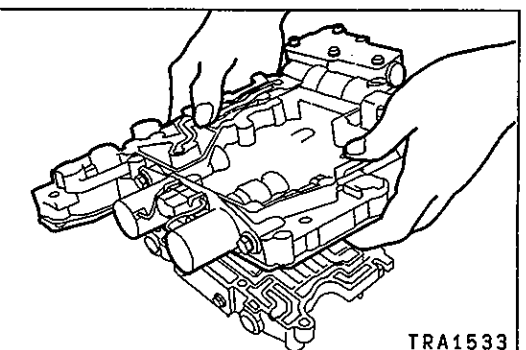

- (6) Lay the lower valve body on the rear upper valve body.

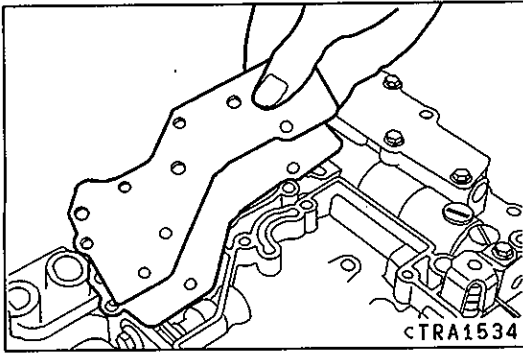

- (7) Attach the valve body cover with a new gasket to the lower valve body.

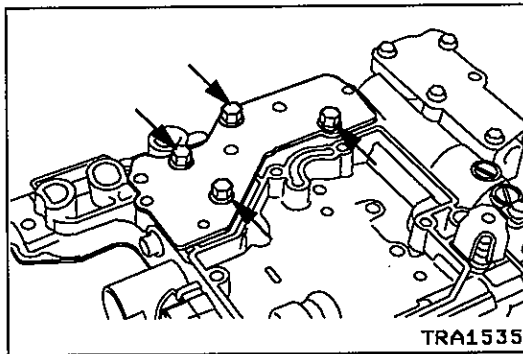

- (8) Tighten the arrowed bolts evenly to secure the valve body cover.

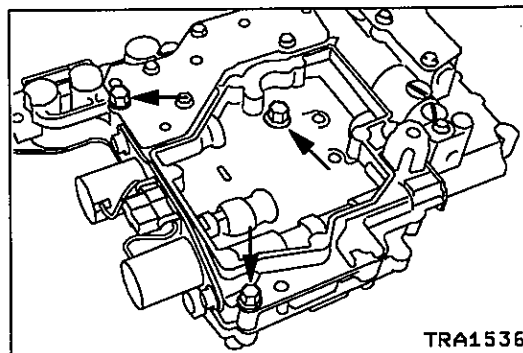

- (9) Attach the bolts at the illustrated positions.

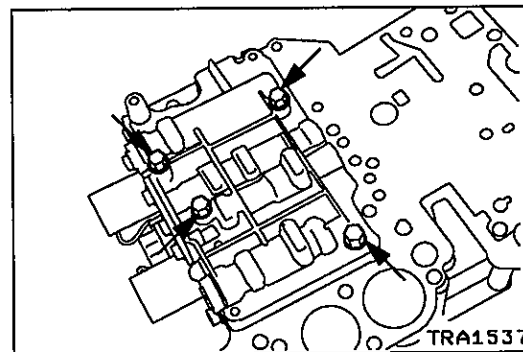

- (10) Turn the valve body over. Attach bolts at the arrowed positions on the rear upper body side, then tighten them fingertight.

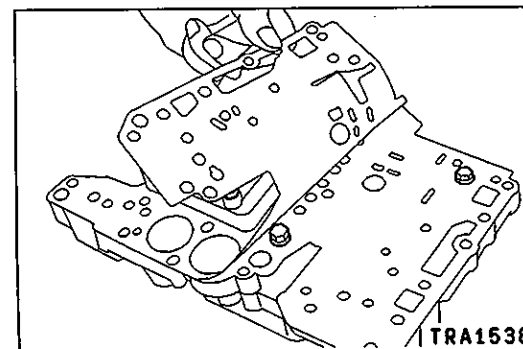

- (11) Remove the bolts which were fastened temporarily in step 4.

**Caution**

- Be careful not to damage the upper valve body gasket during this operation.

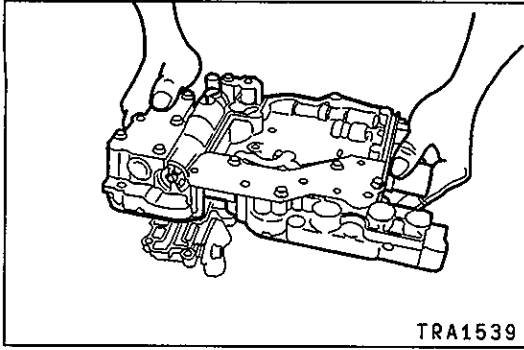

(12) Lay the lower valve body on the front upper valve body.

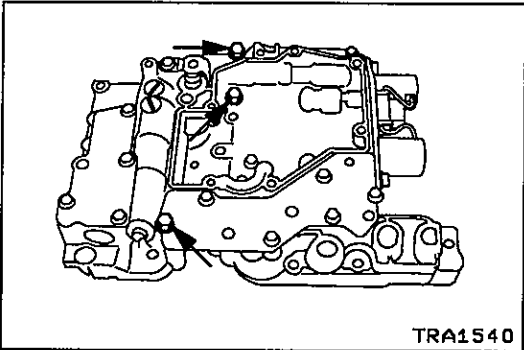

(13) Attach bolts at the arrowed positions.

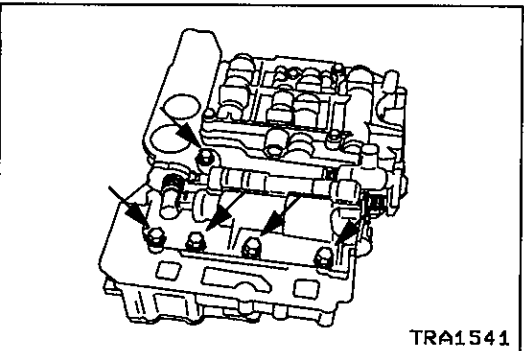

(14) Turn the valve body over and attach bolts at the arrowed positions on the front upper valve body side.

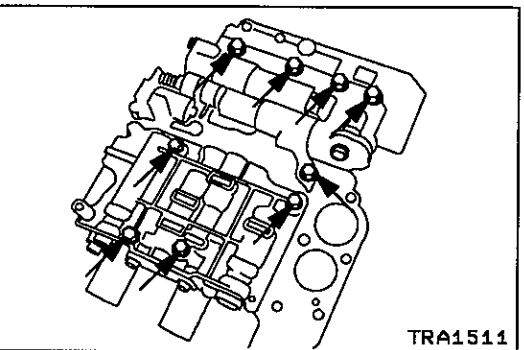

(15) Uniformly tighten the bolts on the rear upper valve body and the bolts on the front upper valve body.

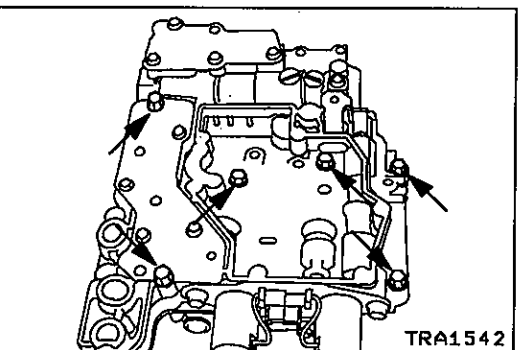

(16) Turn the valve body over and uniformly tighten the bolts on the lower valve body side.

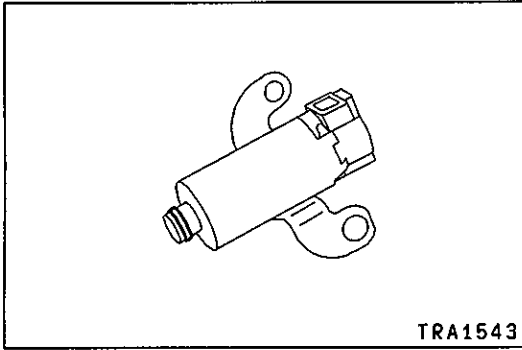

(17) Fit a new O-ring.

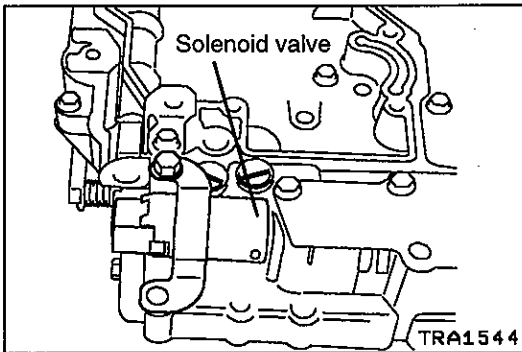

(18) Attach the solenoid valve to the lower valve body.

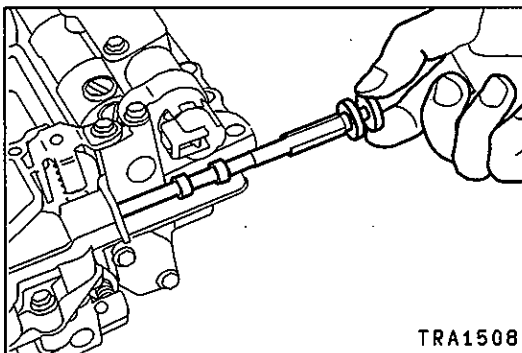

(19) Attach the manual valve.

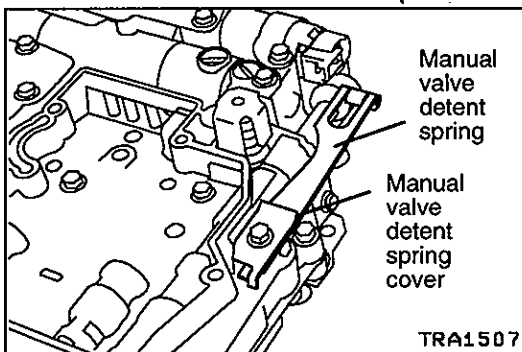

(20) Attach the manual valve detent spring and the manual valve detent spring cover.

**INSPECTION****SOLENOID VALVE**

- (1) Using jumper wires, attach the positive terminal of a battery to the solenoid valve terminal and attach the negative terminal to the solenoid valve body. Verify that the valve can be heard to operate.

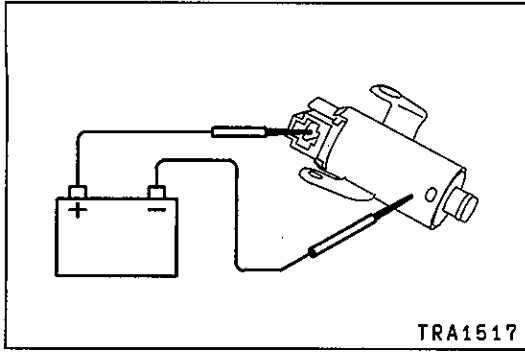

- (2) Measure the resistance between the solenoid valve terminal and the solenoid valve body.

**Standard value: 10 – 16  $\Omega$**

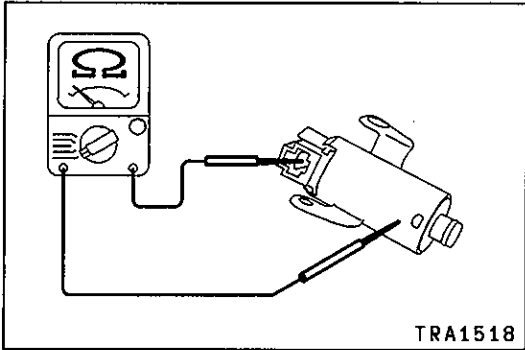



# 15. FRONT UPPER VALVE BODY

## DISASSEMBLY AND REASSEMBLY

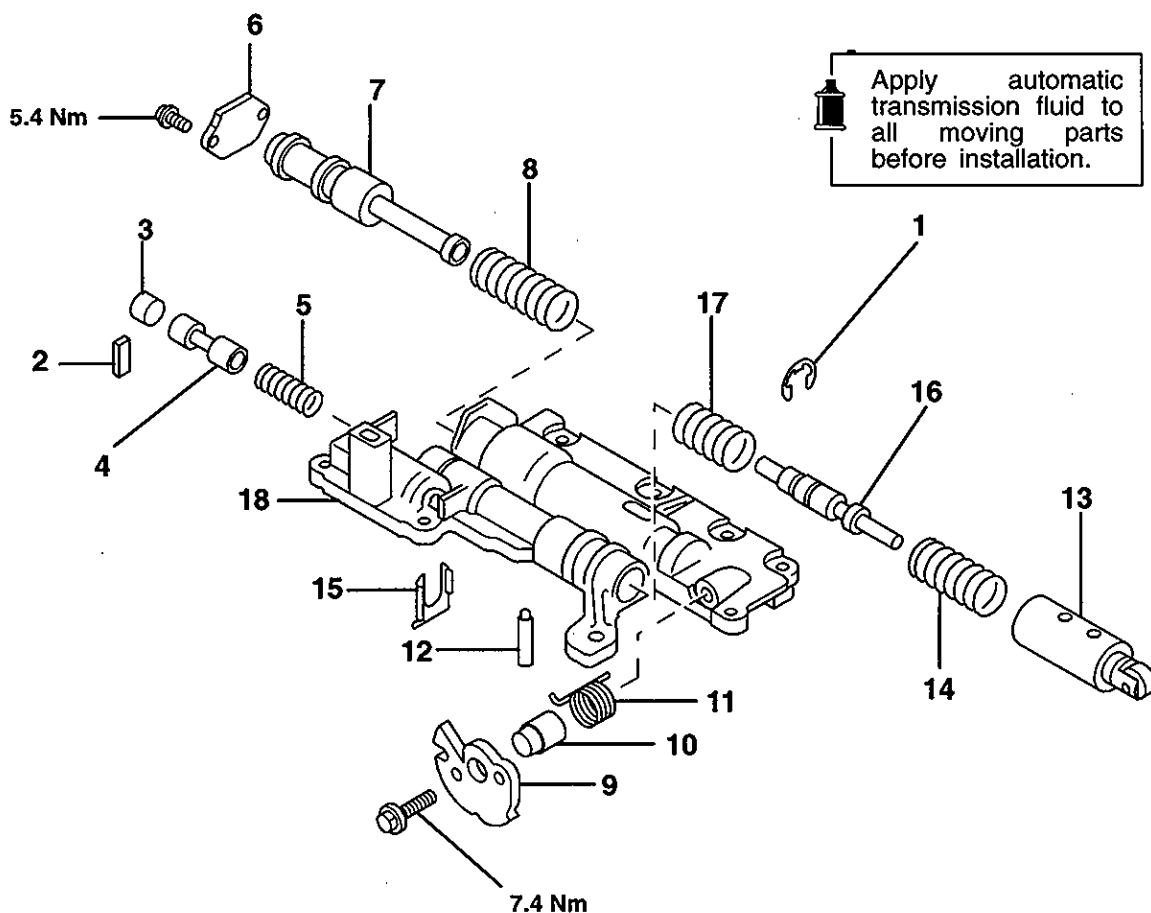

TRA1506

### Disassembly steps

- ◀A▶ ▶C▶ 1. Snap ring
- ▶B▶ 2. Seat
- ▶A▶ 3. Plug
- ▶A▶ 4. Cut-back valve
- ▶A▶ 5. Spring
- ▶A▶ 6. Cover
- ▶A▶ 7. Secondary regulator valve
- ▶A▶ 8. Spring
- ▶A▶ 9. Throttle cam

- ▶B▶ 10. Sleeve
- ▶B▶ 11. Spring
- ▶B▶ 12. Down-shift plug sleeve pin
- ▶A▶ 13. Down-shift plug
- ▶B▶ 14. Spring
- ▶B▶ 15. Valve vibrating stopper
- ▶A▶ 16. Throttle valve
- ▶A▶ 17. Spring
- ▶A▶ 18. Front upper valve body

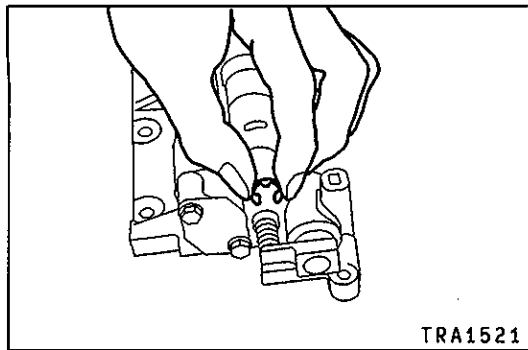
**DISASSEMBLY SERVICE POINT****◀▶ SNAP RING(S) REMOVAL**

- (1) Remove the throttle pressure adjustment snap ring(s).

**Caution**

- Verify the number of snap rings. (Certain cases exist where no snap rings are assembled.)

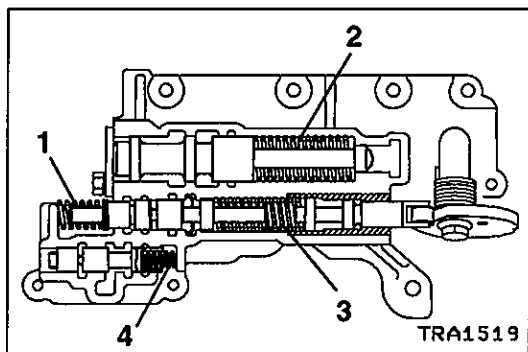
**REASSEMBLY SERVICE POINTS****▶▶ SPRINGS INSTALLATION**

- (1) Correctly install each spring.

	Installation location	Free height (mm)	Outside diameter (mm)
1	Throttle valve	21.94	8.58
2	Secondary regulator valve	71.27	17.43
3	Down-shift plug	39.55	10.90
4	Cut-back plug	23.00	6.85

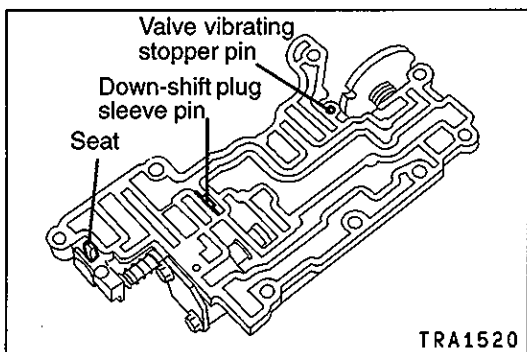
**▶▶ VALVE VIBRATING STOPPER / DOWN-SHIFT PLUG SLEEVE PIN / SEAT INSTALLATION**

- (1) Install the valve vibrating stopper, down-shift plug sleeve pin, and seat as illustrated.

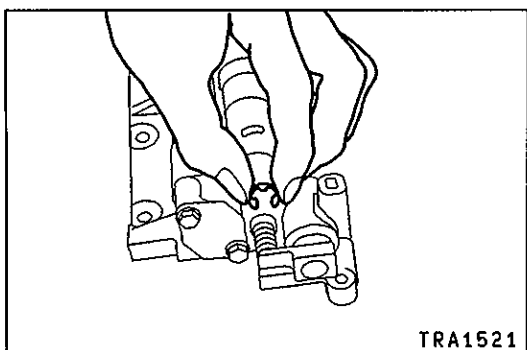
**▶▶ SNAP RING(S) INSTALLATION**

- (1) Install the throttle pressure adjustment snap ring(s).

**Caution**

- Reinstall the same number of snap rings as were originally installed; failure to do so will result in the throttle pressure being altered.

# 16. REAR UPPER VALVE BODY

## DISASSEMBLY AND REASSEMBLY

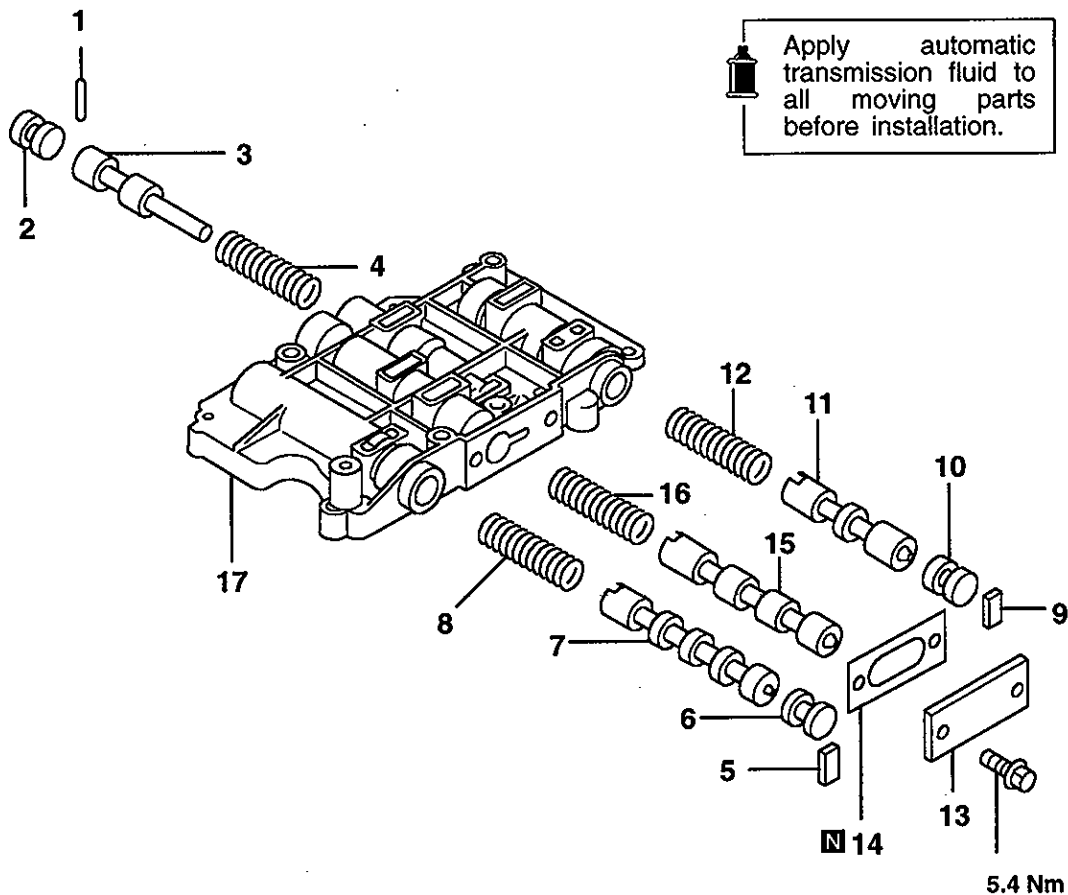

TRA1522

### Disassembly steps

- ▶B◀ 1. Roller
- ▶B◀ 2. Plug
- ▶A◀ 3. Reverse clutch sequence valve
- ▶B◀ 4. Spring
- ▶B◀ 5. Seat
- ▶A◀ 6. Plug
- ▶A◀ 7. 2-3 shift valve
- ▶B◀ 8. Spring
- ▶B◀ 9. Seat

- ▶A◀ 10. Plug
- ▶A◀ 11. 3-4 shift valve
- ▶A◀ 12. Spring
- ▶A◀ 13. Cover
- ▶A◀ 14. Gasket
- ▶A◀ 15. 1-2 shift valve
- ▶A◀ 16. Spring
- ▶A◀ 17. Rear upper valve body

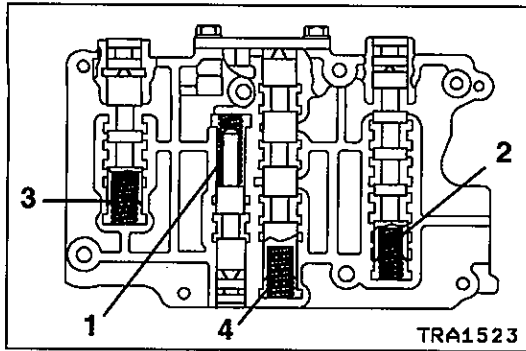

## REASSEMBLY SERVICE POINTS

### ►A◄ SPRINGS INSTALLATION

(1) Correctly install each spring.

	Installation location	Free height (mm)	Outside diameter (mm)
1	Reverse clutch sequence valve	37.55	9.1
2	2-3 shift valve	29.15	8.9
3	3-4 shift valve	29.15	8.9
4	1-2 shift valve	29.15	8.9

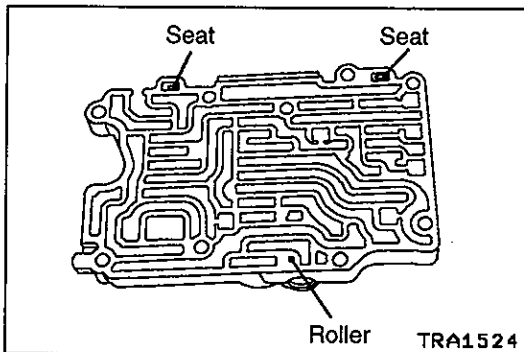

### ►B◄ ROLLER / SEAT INSTALLATION

(1) Install the roller and seats in the illustrated positions.

# 17. LOWER VALVE BODY

## DISASSEMBLY AND REASSEMBLY

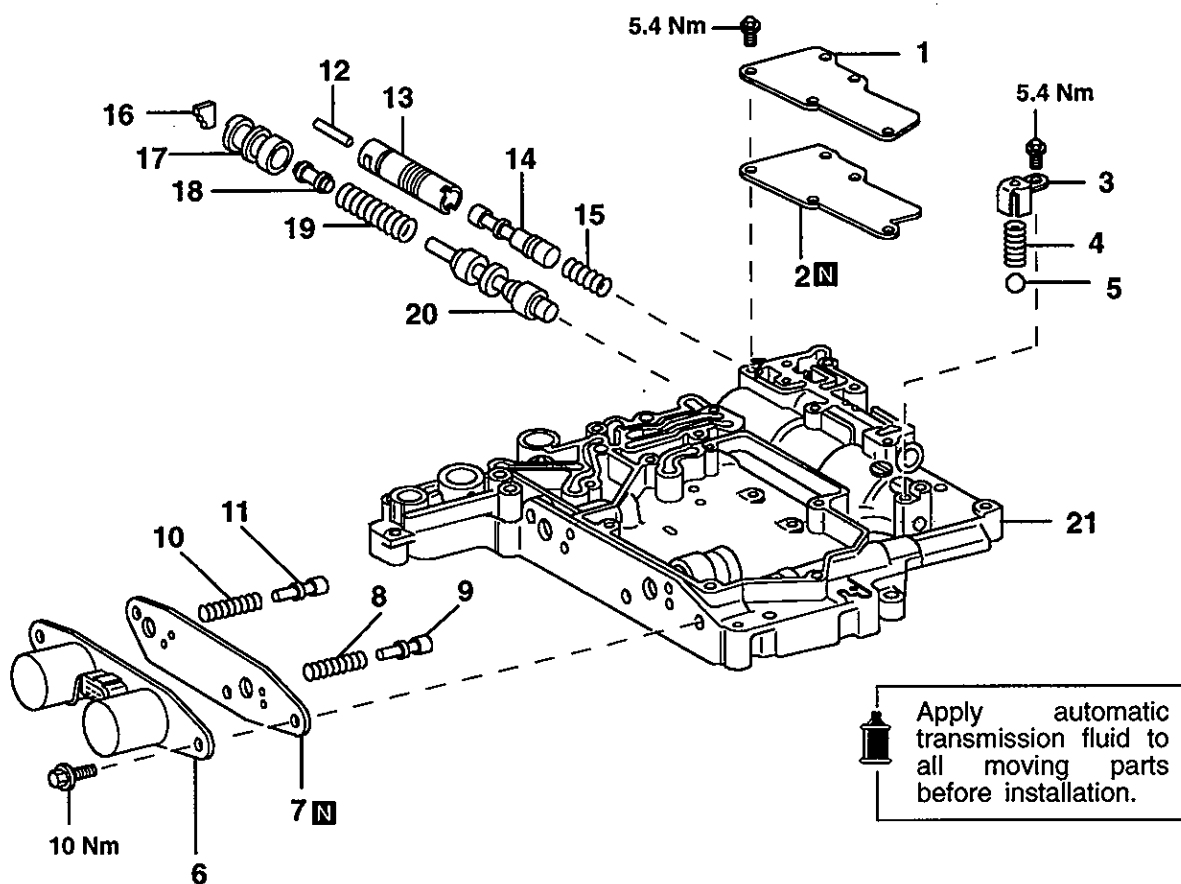

TRA1528

### Disassembly steps

- ▶D◀ 1. Plate
- ▶D◀ 2. Gasket
- ▶A◀ 3. Valve spring seat
- ▶A◀ 4. Spring
- ▶A◀ 5. Ball
- ▶A◀ 6. Solenoid valve
- ▶A◀ 7. Gasket
- ▶A◀ 8. Spring
- ▶A◀ 9. Low coast modulator valve
- ▶A◀ 10. Spring
- ▶A◀ 11. Intermediate modulator valve

- ▶C◀ 12. Pin
- ▶C◀ 13. Sleeve
- ▶A◀ 14. Lock-up relay valve
- ▶A◀ 15. Spring
- ▶B◀ 16. Plate
- ▶B◀ 17. Sleeve
- ▶B◀ 18. Plunger
- ▶A◀ 19. Spring
- ▶A◀ 20. Pressure regulator valve
- ▶A◀ 21. Lower valve body

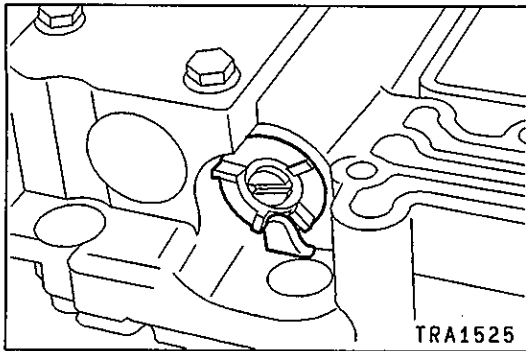
**DISASSEMBLY SERVICE POINT****◀A▶ SLEEVE / PLATE REMOVAL**

- (1) Before proceeding with the disassembly, check what division of the sleeve the plate seats in.

**Caution**

- The sleeve division in which the plate seats determines the line pressure: Always check this before disassembly.

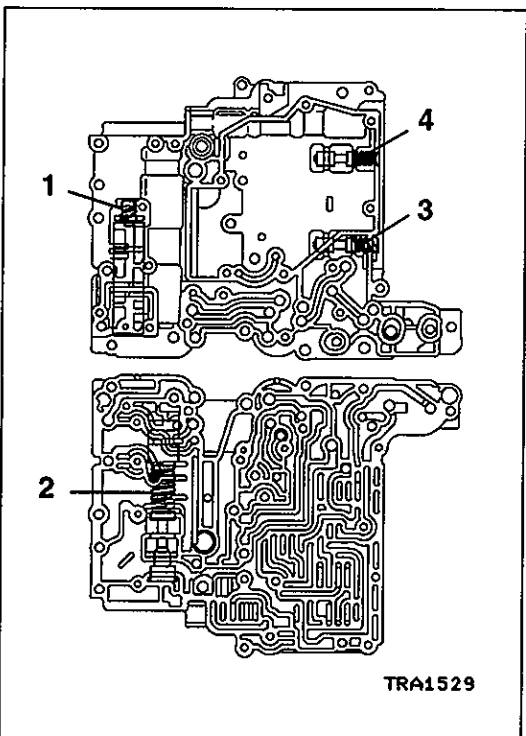
**REASSEMBLY SERVICE POINTS****▶A◀ SPRINGS INSTALLATION**

- (1) Correctly install each spring.

	Installation location	Free height (mm)	Outside diameter (mm)
1	Lock-up relay valve	32.60	11.40
2	Pressure regulator valve	50.28	17.02
3	Intermediate modulator valve	27.26	9.04
4	Low coast modulator valve	42.35	9.24

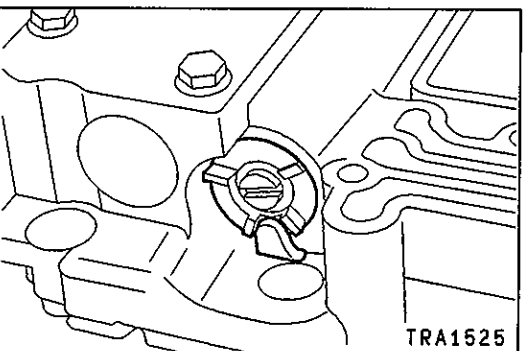
**▶B◀ SLEEVE / PLATE INSTALLATION**

- (1) Install the plate in such a way that it may seat in the same sleeve position as prior to disassembly.

**Caution**

- The sleeve division in which the plate seats determines the line pressure: Always let the plate seat on the sleeve in the division which was verified before disassembly.

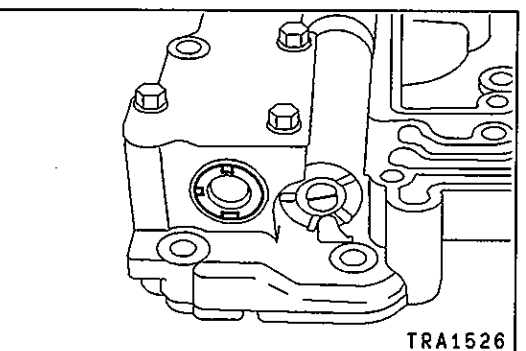
**▶C◀ SLEEVE / PIN INSTALLATION**

- (1) Install the sleeve such that its three notches are located as illustrated, then secure with the pin.

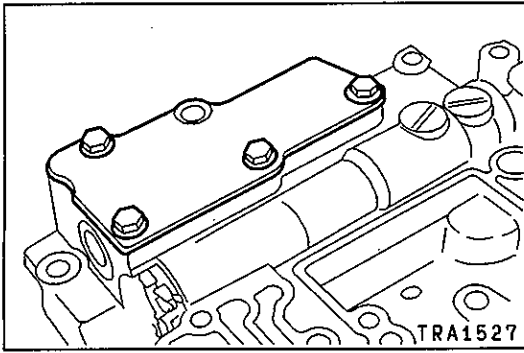
**▶D◀ PLATE / GASKET INSTALLATION**

- (1) Install the plate together with a new gasket. Uniformly tighten the bolts indicated in the illustration.

---

## NOTES



# 18. TRANSFER

## DISASSEMBLY AND REASSEMBLY

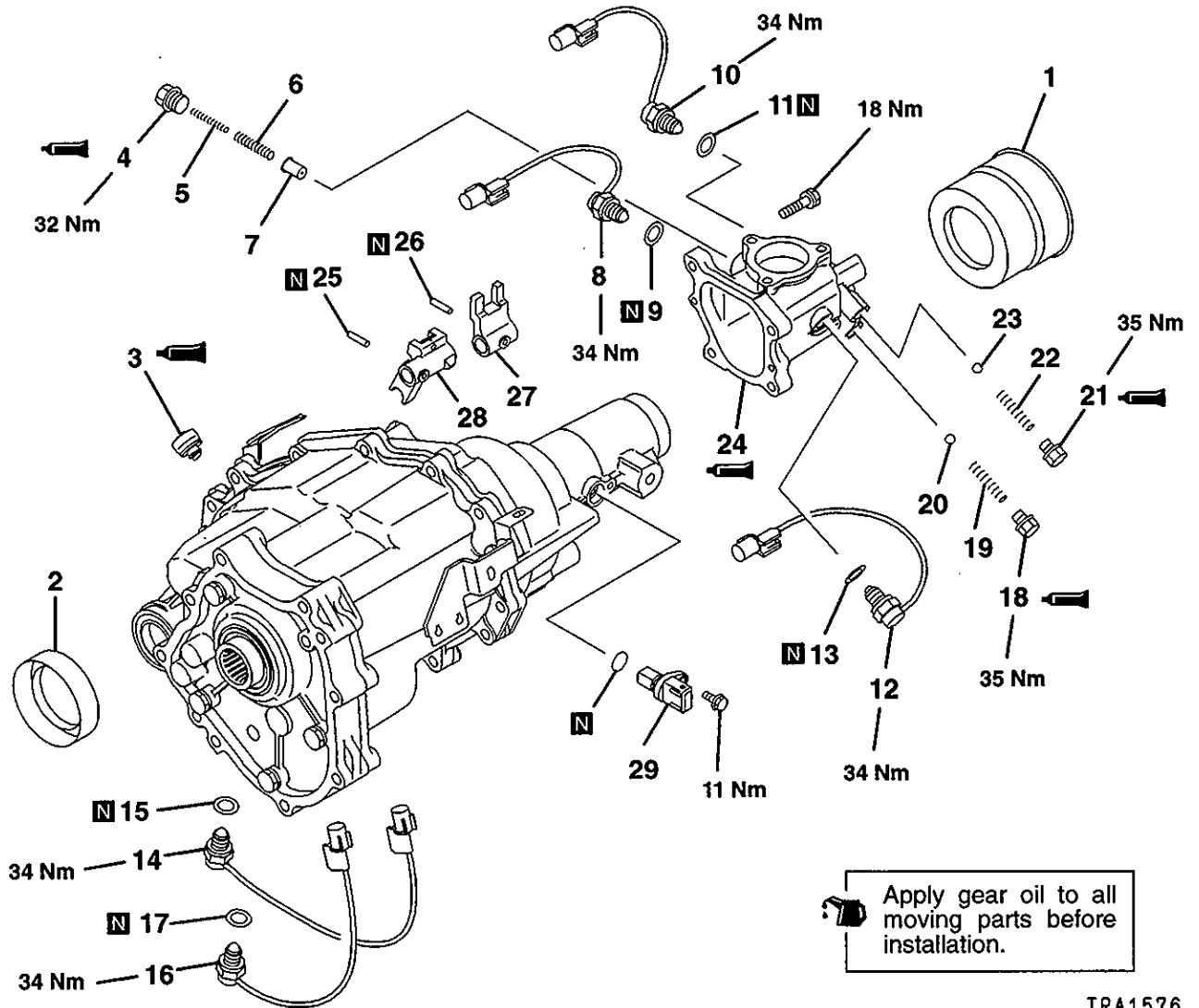

TRA1576

### Disassembly steps

- 1. Dust seal guard
- 2. Dust seal guard
- ▶d◀ 3. Air breather
- ▶c◀ 4. Select plunger seal plug
- 5. Return spring
- 6. Return spring
- 7. Select plunger
- ▶b◀ 8. Hi-Lo detector switch
- 9. Gasket
- ▶b◀ 10. 4WD operation detector switch
- 11. Gasket
- ▶a◀ 12. Lock operation detector switch
- 13. Gasket
- ▶Z◀ 14. 4WD detector switch
- 15. Gasket

- ▶Z◀ 16. Lock detector switch
- 17. Gasket
- ▶Y◀ 18. Poppet seal bolt
- ▶X◀ 19. Spring
- 20. Steel ball
- ▶Y◀ 21. Poppet seal bolt
- ▶X◀ 22. Spring
- 23. Steel ball
- ▶A◀ ▶W◀ 24. Transfer control housing
- ▶V◀ 25. Spring pin
- ▶U◀ 26. Spring pin
- ▶T◀ 27. Hi-Lo shift lug
- 28. 2WD/4WD shift lug
- 29. Vehicle speed sensor

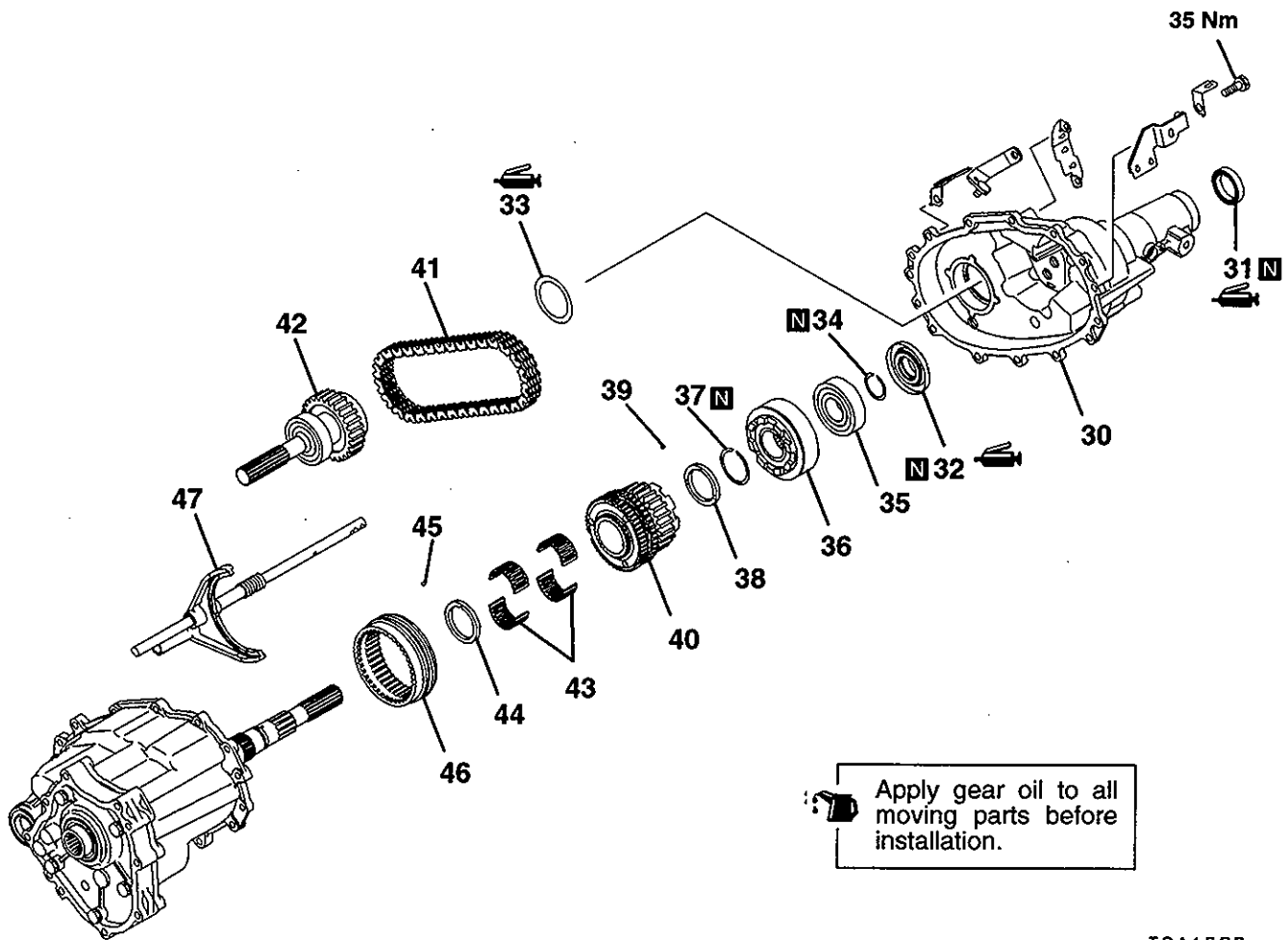

TRA1577

**Disassembly steps**

- ◀B▶ ▶S▶ 30. Transfer rear cover
- ▶R▶ 31. Oil seal
- ▶Q▶ 32. Oil guide
- ▶P▶ 33. Wave spring
- ▶O▶ 34. Snap ring
- ◀C▶ ▶N▶ 35. Ball bearing
- ▶M▶ 36. Viscous coupling
- ▶L▶ 37. Snap ring
- ▶L▶ 38. Spacer

- ▶D▶ ▶K▶ 39. Steel ball
- ▶D▶ ▶K▶ 40. 2WD/4WD synchronizer
- ▶D▶ ▶K▶ 41. Chain
- ▶K▶ 42. Front output shaft
- ▶J▶ 43. Needle bearings
- ▶I▶ 44. Spacer
- ▶I▶ 45. Steel ball
- ▶I▶ 46. Synchronizer sleeve
- ▶I▶ 47. 2WD/4WD shift fork and rail

Apply gear oil to all moving parts before installation.

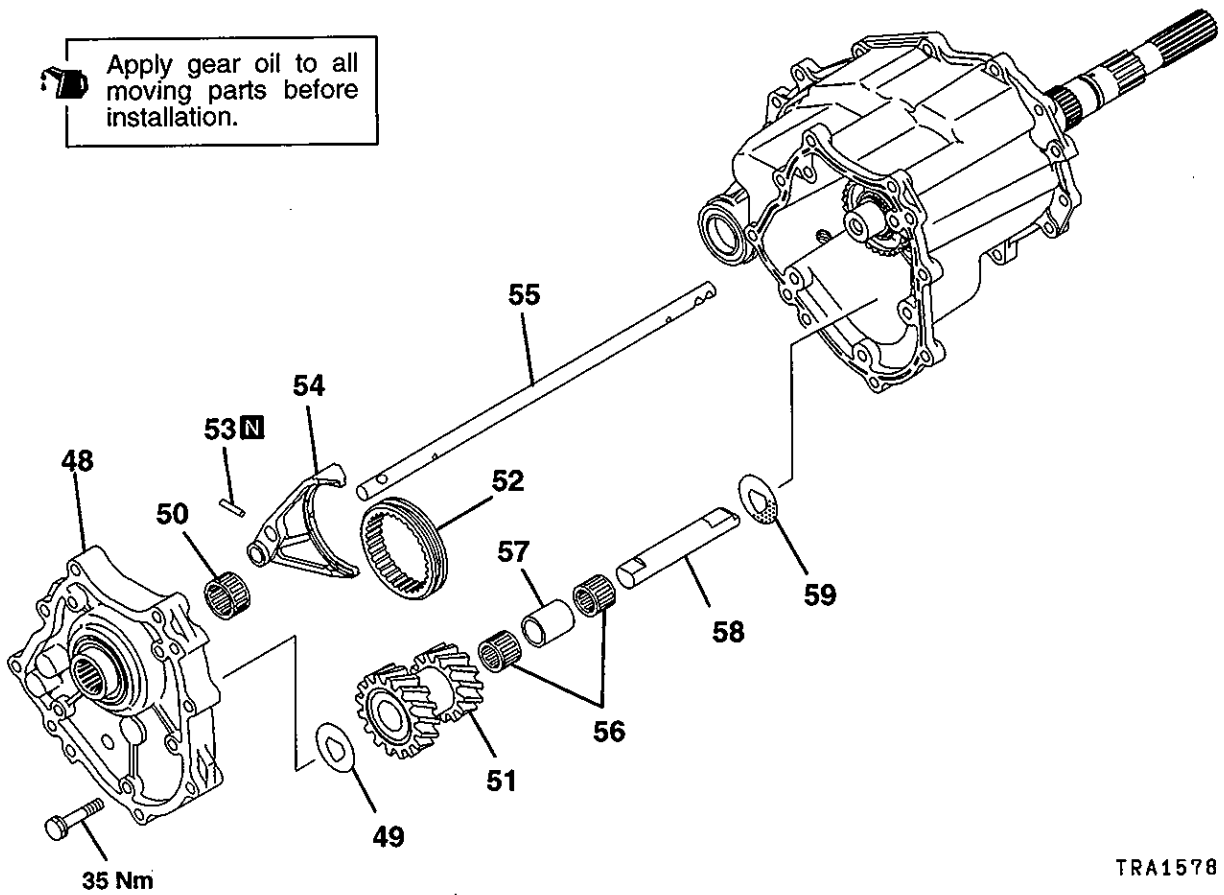

TRA1578

**Disassembly steps**

- ◀E▶ ▶H▶ 48. Transfer case plate
- ▶G▶ 49. Thrust washer
- ▶F▶ 50. Needle bearing
- ▶E▶ 51. Counter gear
- ▶F▶ 52. Hi-Lo clutch sleeve
- ▶E▶ 53. Spring pin

- ▶E▶ 54. Hi-Lo shift fork
- ▶E▶ 55. Hi-Lo shift rail
- ▶E▶ 56. Needle bearings
- ▶D▶ 57. Bearing spacer
- ▶D▶ 58. Counter gear shaft
- ▶D▶ 59. Thrust washer

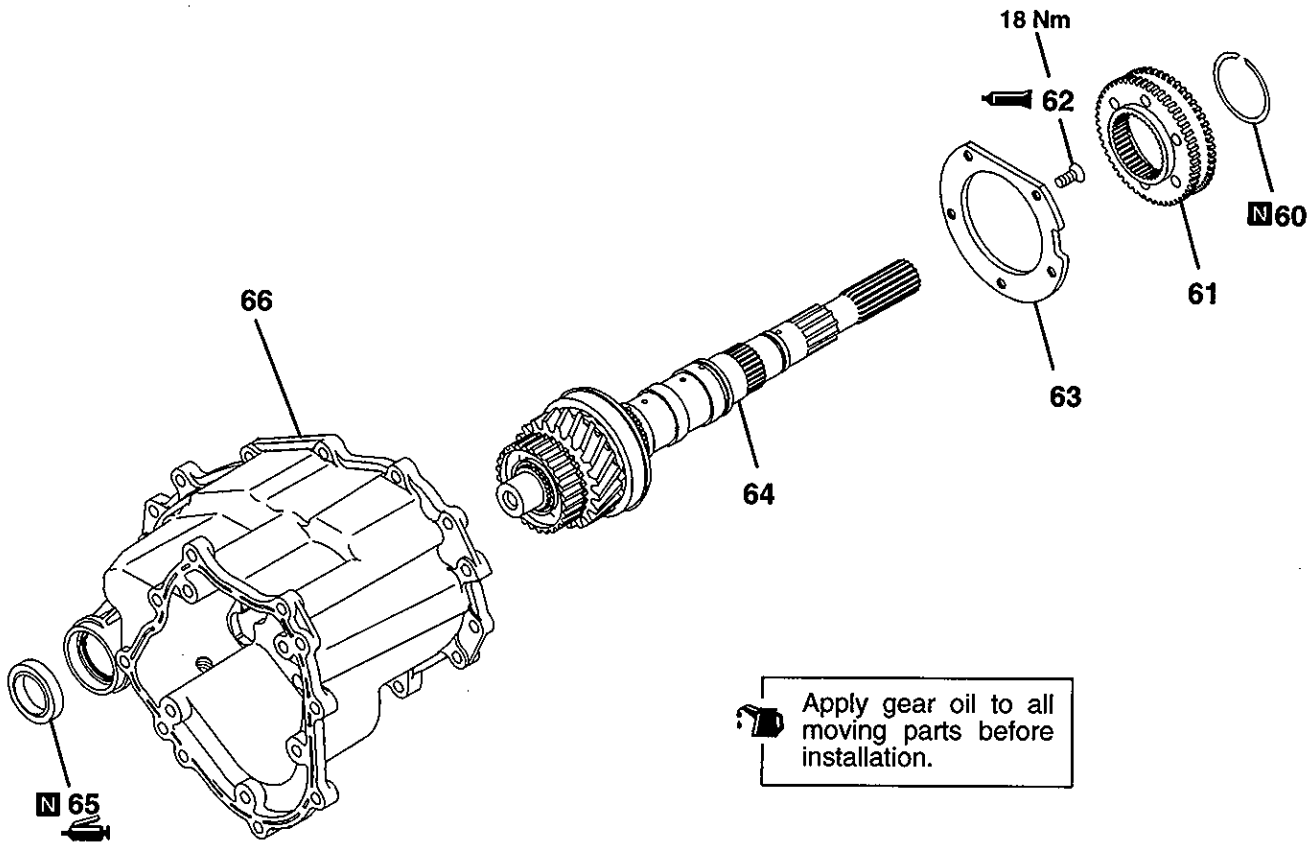

TRA1579

**Disassembly steps**

- ▶C◀ 60. Snap ring
- 61. Differential lock hub
- ▶B◀ 62. Center bearing retainer seal bolt
- 63. Center bearing retainer
- 64. Rear output shaft
- ▶A◀ 65. Oil seal
- 66. Transfer case

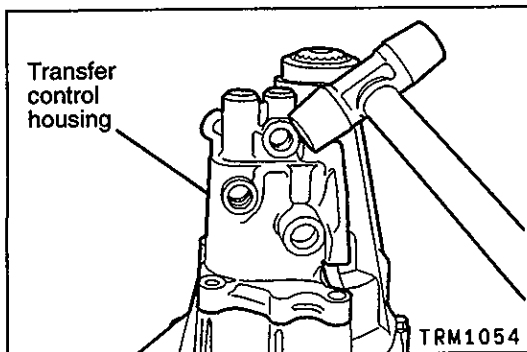
**DISASSEMBLY SERVICE POINTS****◀A▶ TRANSFER CONTROL HOUSING REMOVAL**

- (1) Remove the transfer control housing by tapping lightly with a plastic hammer or some other similar tool.

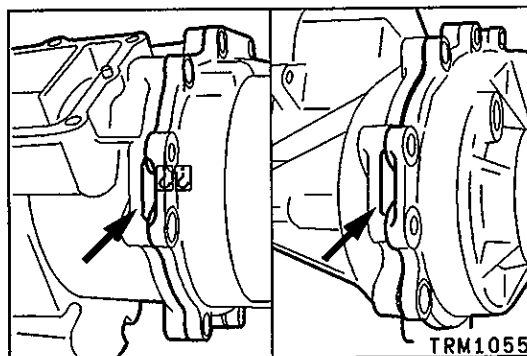
**◀B▶ TRANSFER REAR COVER REMOVAL**

- (1) Tap the transfer rear cover at the two locations indicated in the illustration to remove it.

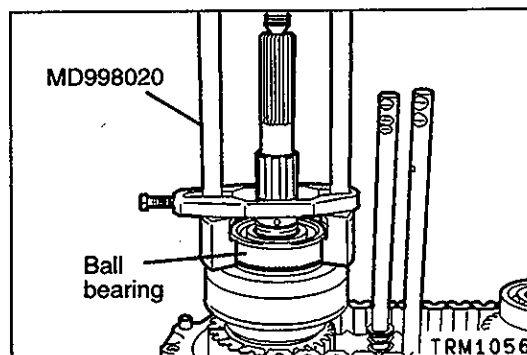
**◀C▶ BALL BEARING REMOVAL**

- (1) Remove the ball bearing using the indicated special tool.

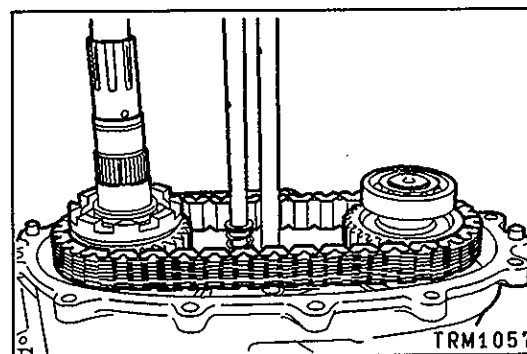
**◀D▶ 2WD/4WD SYNCHRONIZER / CHAIN / FRONT OUTPUT SHAFT REMOVAL**

- (1) Remove the 2WD/4WD synchronizer, chain, and front output shaft at the same time.

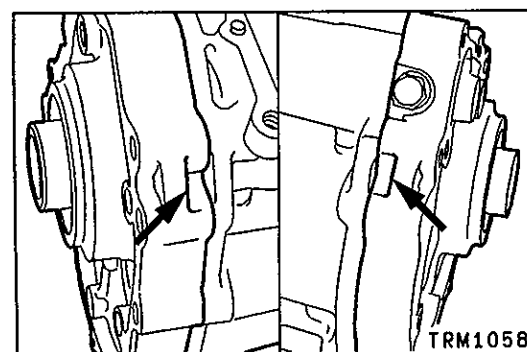
**◀E▶ TRANSFER CASE PLATE REMOVAL**

- (1) Tap the transfer case plate at the two locations indicated in the illustration to remove it.

**Caution**

- The counter gear and ancillary parts will be freed together; take care to avoid letting them fall.

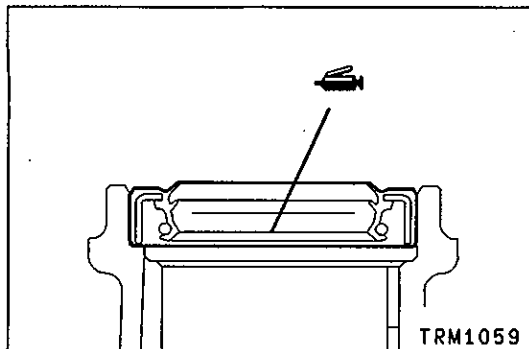

## REASSEMBLY SERVICE POINTS

### ▶A◀ OIL SEAL INSTALLATION

- (1) Apply grease to the lip of the oil seal; then assemble the seal using the indicated special tool.

#### Specified grease:

**Mitsubishi genuine grease Part No. MD0101011 or equivalent**

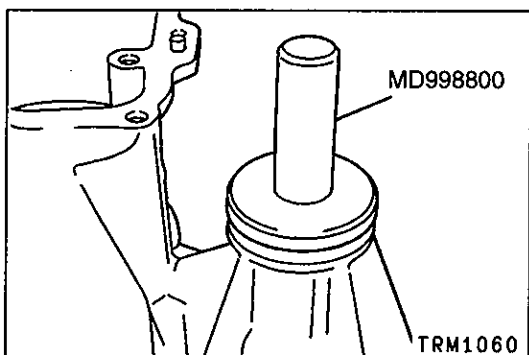

### ▶B◀ CENTER BEARING RETAINER SEAL BOLT INSTALLATION (when reused)

- (1) Apply sealant to the threaded area of the bolt indicated in the illustration; following this, tighten to the specified torque.

#### Specified sealant:

**3M STUD Locking No. 4170 or equivalent**

#### NOTE

Ensure that any old sealant still adhering to the seal bolt is fully removed.

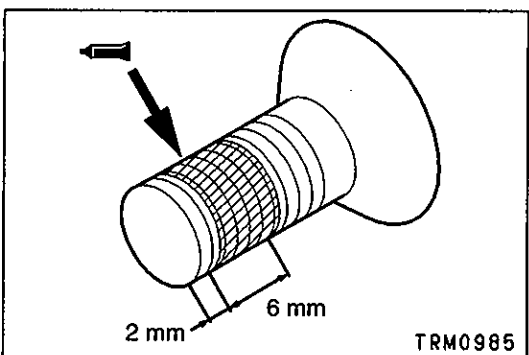

### ▶C◀ SNAP RING INSTALLATION

- (1) Select and install a suitable snap ring to ensure that the differential lock hub end play is at the standard value.

**Standard value: 0 – 0.08 mm**

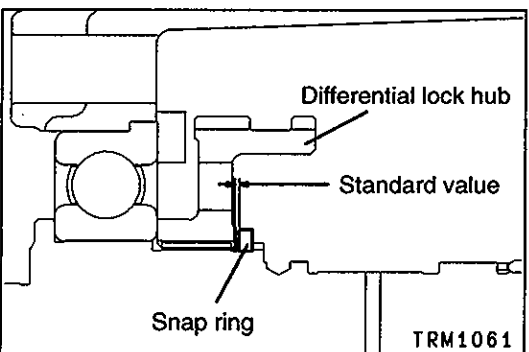

### ▶D◀ THRUST WASHER / COUNTER GEAR SHAFT INSTALLATION

- (1) Install the thrust washer on the counter gear shaft as shown with the oil grooves in the washer oriented in the indicated direction.

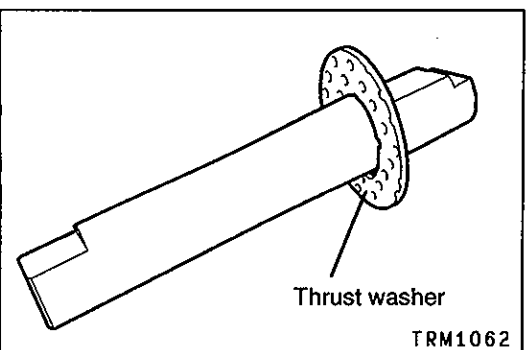

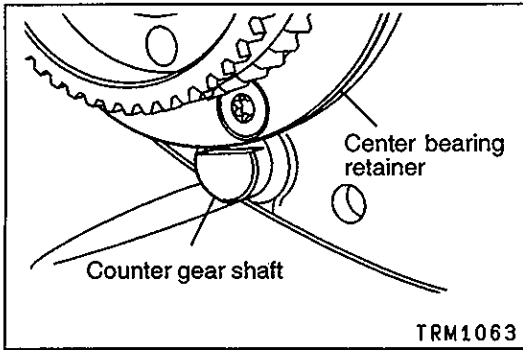

- (2) Install the counter gear shaft with its notch toward the center bearing retainer so that it can be prevented from turning by the retainer.

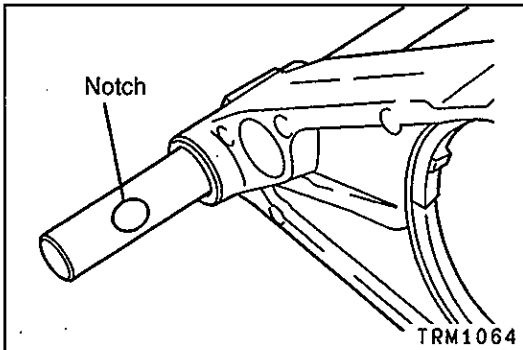

#### ►E◄ HI-LO SHIFT RAIL / HI-LO SHIFT FORK / SPRING PIN INSTALLATION

- (1) Assemble the Hi-Lo shift rail and Hi-Lo shift fork in such a way that they are oriented as shown.

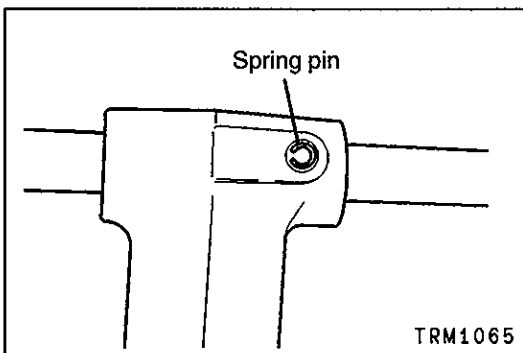

- (2) Drive in the spring pin with its slit oriented as shown.

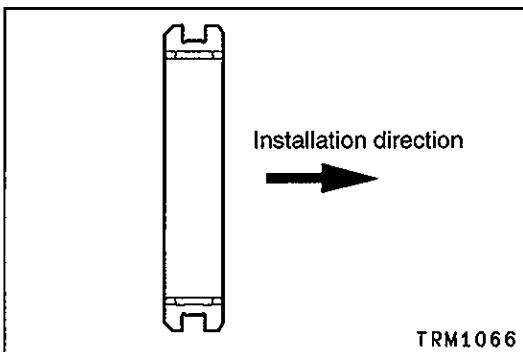

#### ►F◄ HI-LO CLUTCH SLEEVE INSTALLATION

- (1) Install the Hi-Lo clutch sleeve in the indicated orientation.

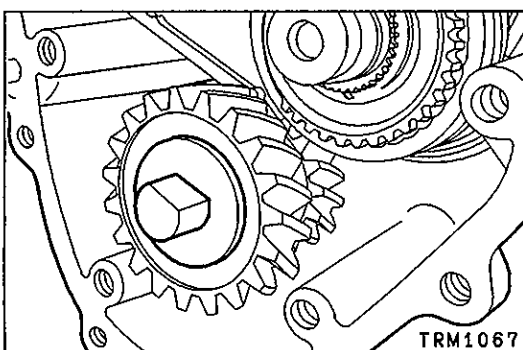

#### ►G◄ THRUST WASHER INSTALLATION

- (1) Align the flat of the thrust washer with that of the counter gear shaft, then install the thrust washer with its oil-grooved surface facing the counter gear.

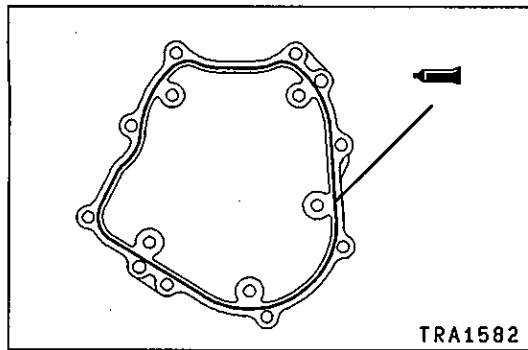

### ►H◄ TRANSFER CASE PLATE INSTALLATION

- (1) Apply sealant to the transfer case plate mounting surface of the transfer case.

#### Specified sealant:

Mitsubishi genuine sealant Part No. MD997740 or equivalent

#### Caution

- Squeeze the sealant out evenly to ensure that the bead is not broken and that over-application is not performed.
- (2) Direct the notch in the input gear toward the counter gear, then install the transfer case plate.

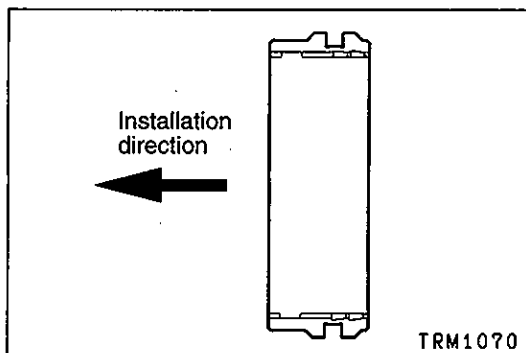

### ►I◄ 2WD/4WD SHIFT FORK, SHIFT RAIL / SYNCHRONIZER SLEEVE INSTALLATION

- (1) Install the synchronizer sleeve in the indicated direction.

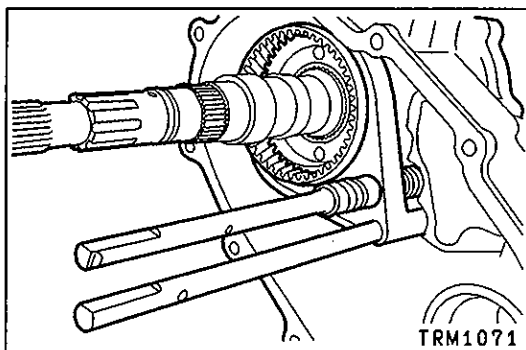

- (2) Shift the Hi-Lo shift rail in the illustrated position, then assemble the synchronizer sleeve, the 2WD/4WD shift fork, and the shift rail.

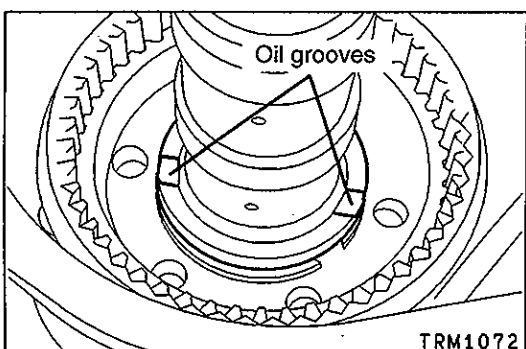

### ►J◄ SPACER INSTALLATION

- (1) Install the spacer with its oil grooves oriented as indicated.



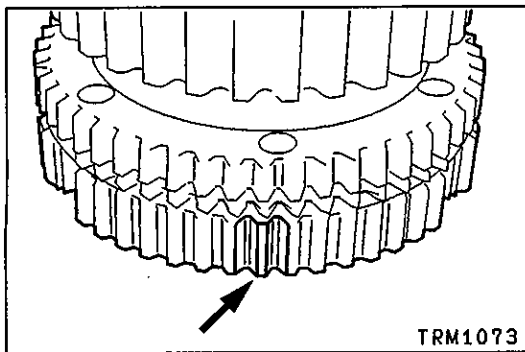

### ►K◄ FRONT OUTPUT SHAFT / CHAIN / 2WD/4WD SYNCHRONIZER INSTALLATION

- (1) Apply white paint or something similar to the three deep tooth grooves in the 2WD/4WD synchronizer sprocket.

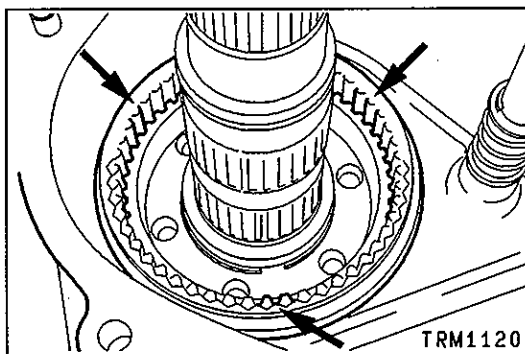

- (2) Apply white paint or something similar to the three spline projections on the synchronizer sleeve.

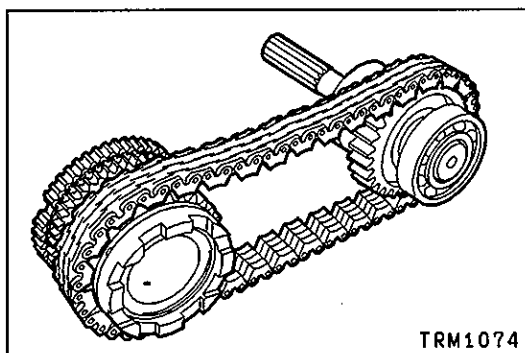

- (3) Mesh the chain with the 2WD/4WD synchronizer sprocket and the front output shaft sprocket.
- (4) With the sprockets distanced as far from each other as possible, install the assembly in the case while aligning the markings made in steps (1) and (2) above.

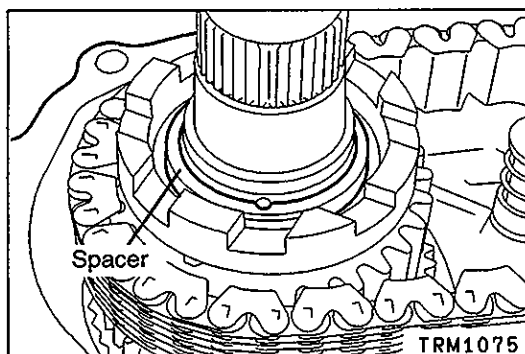

### ►L◄ SPACER INSTALLATION

- (1) Install the spacer with its oil grooves facing the 2WD/4WD synchronizer.

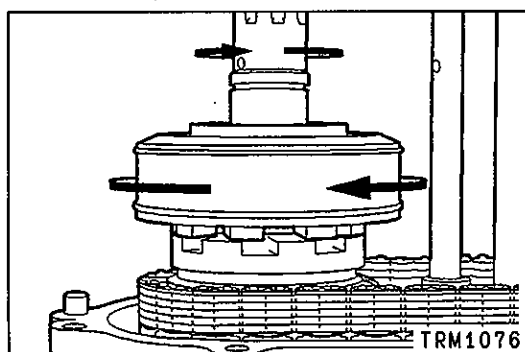

### ►M◄ VISCOUS COUPLING INSTALLATION

- (1) If the grooves in the viscous coupling and the 2WD/4WD synchronizer are not aligned, slowly rotate either the rear output shaft or the viscous coupling itself to bring each into alignment.

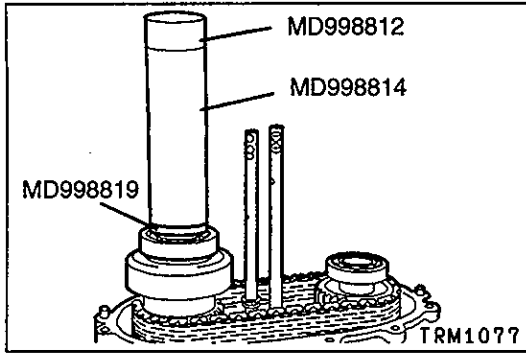

### ▶N◀ BALL BEARING INSTALLATION

- (1) Assemble the ball bearing using the indicated special tools.

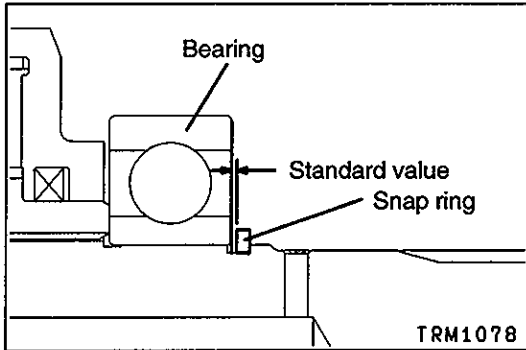

### ▶O◀ SNAP RING INSTALLATION

- (1) Select and install a suitable snap ring to ensure that the rear output shaft rear bearing clearance is at the standard value.

**Standard value: 0 – 0.08 mm**

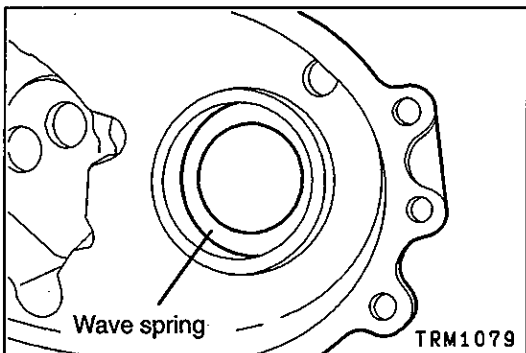

### ▶P◀ WAVE SPRING INSTALLATION

- (1) Apply grease to the wave spring and secure it to the transfer rear cover.

**Specified grease:**  
**Mitsubishi genuine grease Part No. MD0101011**  
**or equivalent**

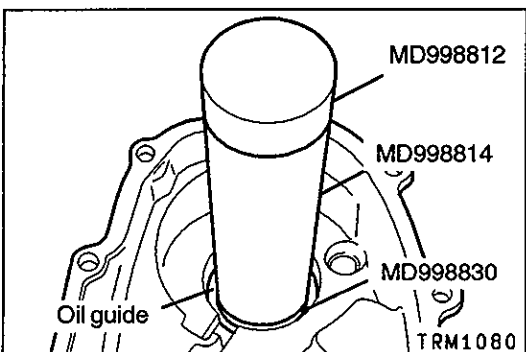

### ▶Q◀ OIL GUIDE INSTALLATION

- (1) Install the oil guide using the indicated special tools.

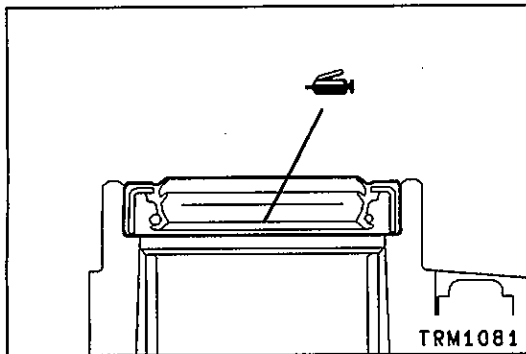

### ►R◄ OIL SEAL INSTALLATION

- (1) Apply grease to the lip of the oil seal; then assemble the seal using the indicated special tool.

#### Specified grease:

**Mitsubishi genuine grease Part No. MD0101011 or equivalent**

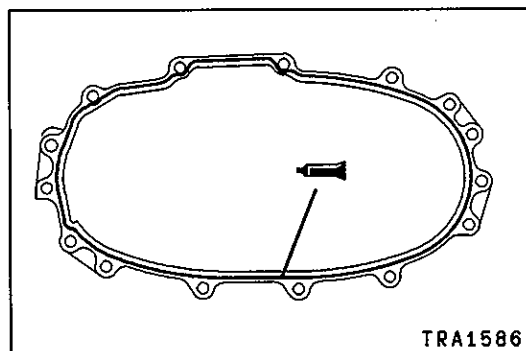
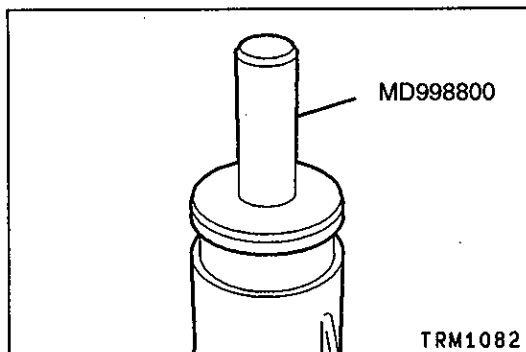

### ►S◄ TRANSFER REAR COVER INSTALLATION

- (1) Apply sealant to the transfer rear cover mounting surface of the transfer case.

#### Specified sealant:

**Mitsubishi genuine sealant Part No. MD997740 or equivalent**

#### Caution

- Squeeze the sealant out evenly to ensure that the bead is not broken and that over-application is not performed.

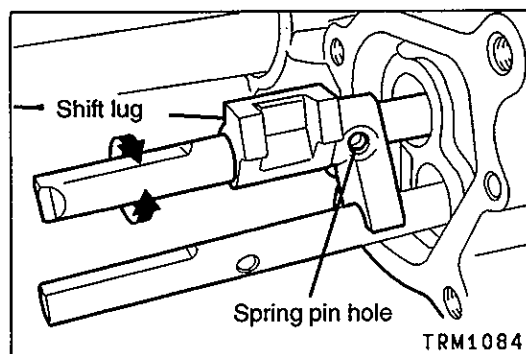

### ►T◄ 2WD/4WD SHIFT LUG INSTALLATION

- (1) Rotate the 2WD/4WD shift rail to line up the spring pin hole in the 2WD/4WD shift lug with that in the shift rail.

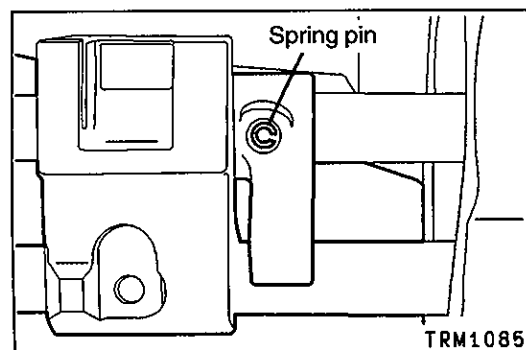

### ►U◄ SPRING PIN INSTALLATION

- (1) Drive in the spring pin in such a way that its slit is oriented as shown.

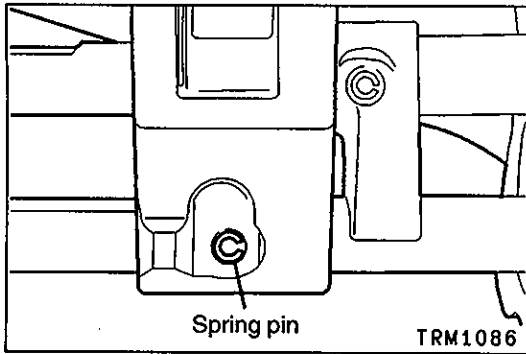

### ►V◄ SPRING PIN INSTALLATION

- (1) Drive in the spring pin in such a way that its slit is oriented as shown.

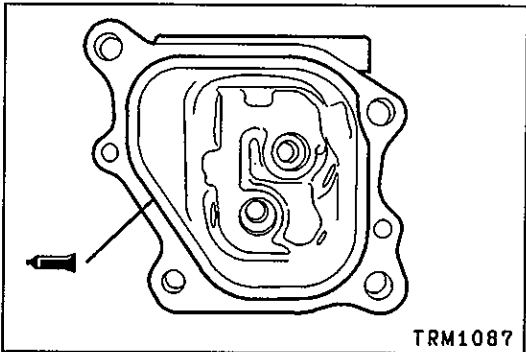

### ►W◄ TRANSFER CONTROL HOUSING INSTALLATION

- (1) Apply sealant to the transfer control housing at the indicated position.

#### Specified sealant:

Mitsubishi genuine sealant Part No. MD997740 or equivalent

#### Caution

- Squeeze the sealant out evenly to ensure that the bead is not broken and that over-application is not performed.

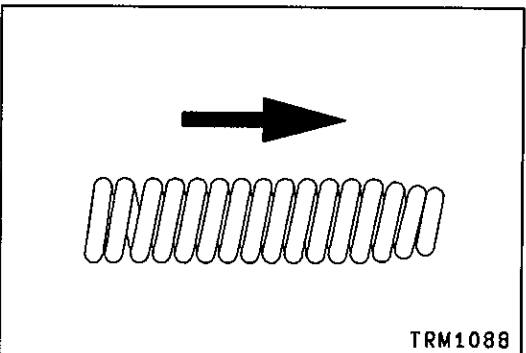

### ►X◄ SPRING INSTALLATION

- (1) Install the spring with the tapered end facing the ball side.

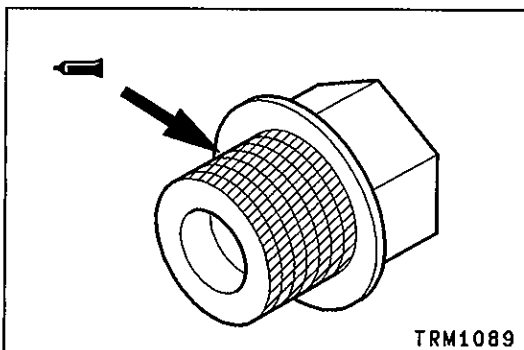

### ►Y◄ POPPET SEAL BOLT INSTALLATION (when reused)

- (1) Apply sealant to the threaded area of the poppet seal bolt before tightening to the specified torque.

#### Specified sealant:

3M ATD Part No. 8660 or equivalent

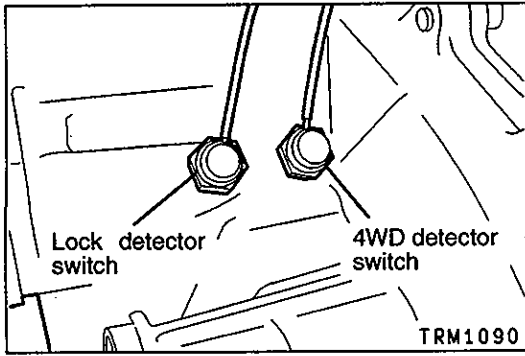

**▶Z◀ LOCK DETECTOR SWITCH / 4WD DETECTOR SWITCH INSTALLATION**

- (1) Install each of the detector switches at the correct position.

Name	Connector color	Harness tube color
Lock detector switch	Brown	Black
4WD detector switch	White	Black

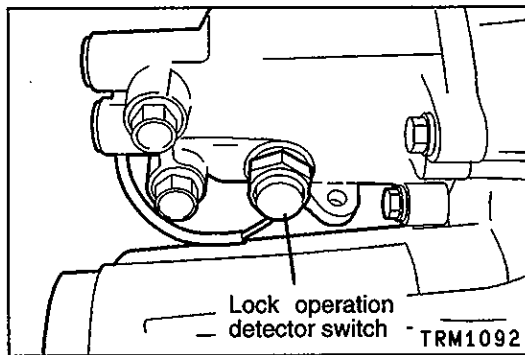
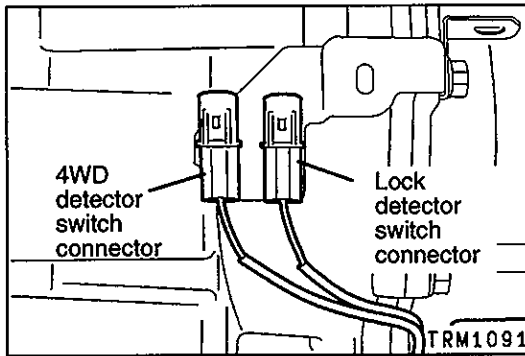

**▶a◀ LOCK OPERATION DETECTOR SWITCH INSTALLATION**

- (1) Install the detector switch as illustrated.

Name	Connector color	Harness tube color
Lock operation detector switch	Brown	Yellow

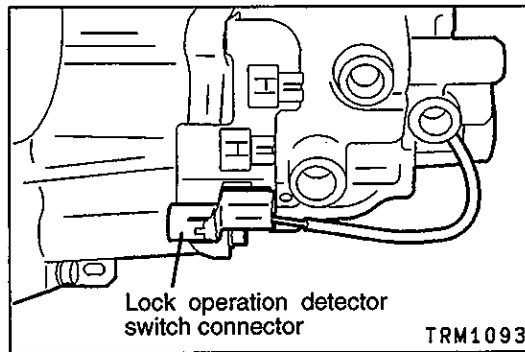

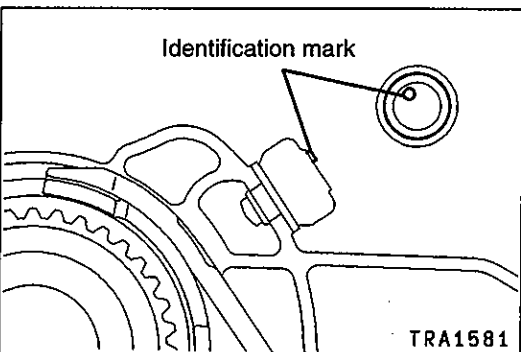
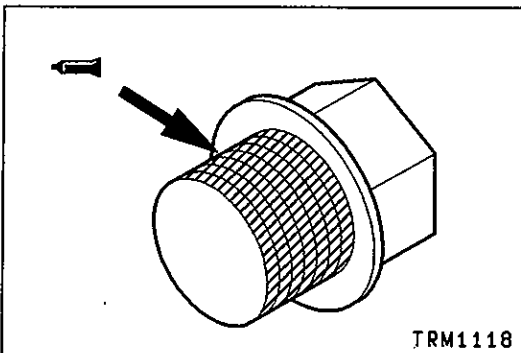
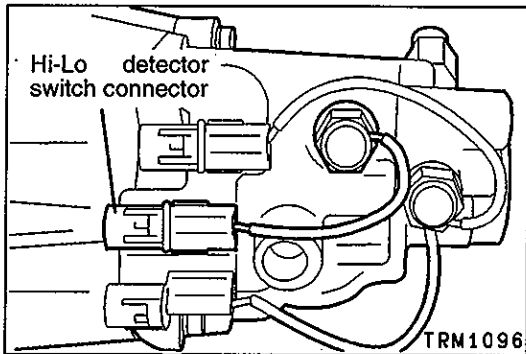
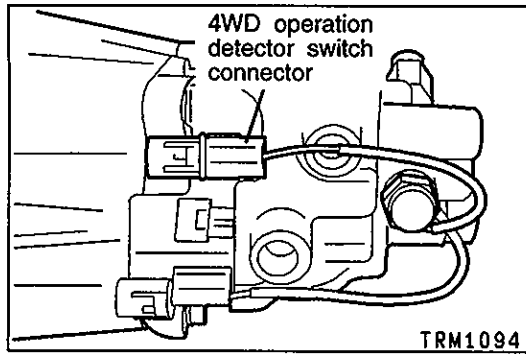

### ►b◄ 4WD OPERATION DETECTOR SWITCH / HI-LO DETECTOR SWITCH INSTALLATION

- (1) Install each of these detector switches as illustrated.

Name	Connector color	Harness tube color
4WD operation detector switch	White	Blue
Hi-Lo detector switch	Black	Black

### ►c◄ SELECT PLUNGER SEAL PLUG INSTALLATION (when reused)

- (1) Apply sealant to the threaded area of the seal plug before tightening to the specified torque.

**Specified sealant:**  
3M ATD Part No. 8660 or equivalent

### ►d◄ AIR BREATHER INSTALLATION

- (1) Apply sealant to the air breather's mounting area.

**Specified sealant:**  
Mitsubishi genuine sealant Part No. MD997740 or equivalent

- (2) Assemble the air breather with the identification mark facing upward.

## 19. 2WD/4WD SHIFT FORK AND RAIL

### DISASSEMBLY AND REASSEMBLY

 Apply gear oil to all moving parts before installation.

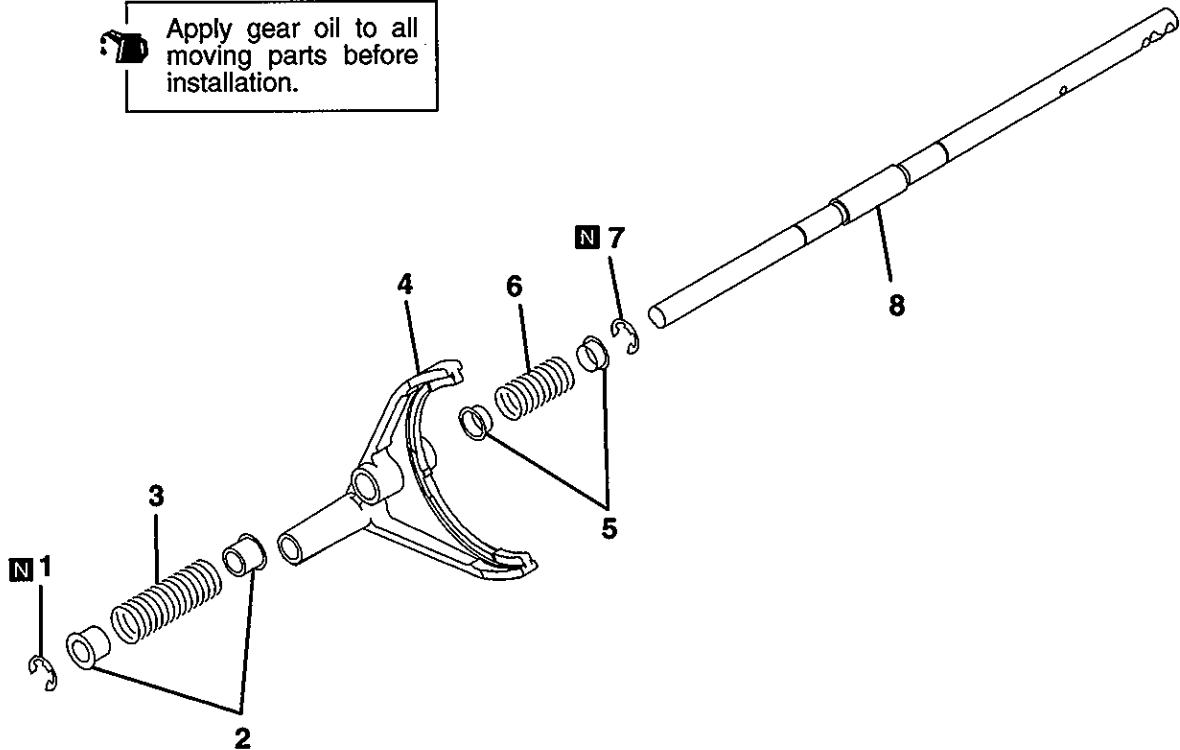

TRM1097

#### Disassembly steps

1. Snap ring
2. Spring retainers
3. Return spring
4. 2WD/4WD shift fork
5. Spring retainers
6. Return spring
7. Snap ring
8. 2WD/4WD shift rail

---

**NOTES**



## 20. 2WD/4WD SYNCHRONIZER

### DISASSEMBLY AND REASSEMBLY

 Apply gear oil to all moving parts before installation.

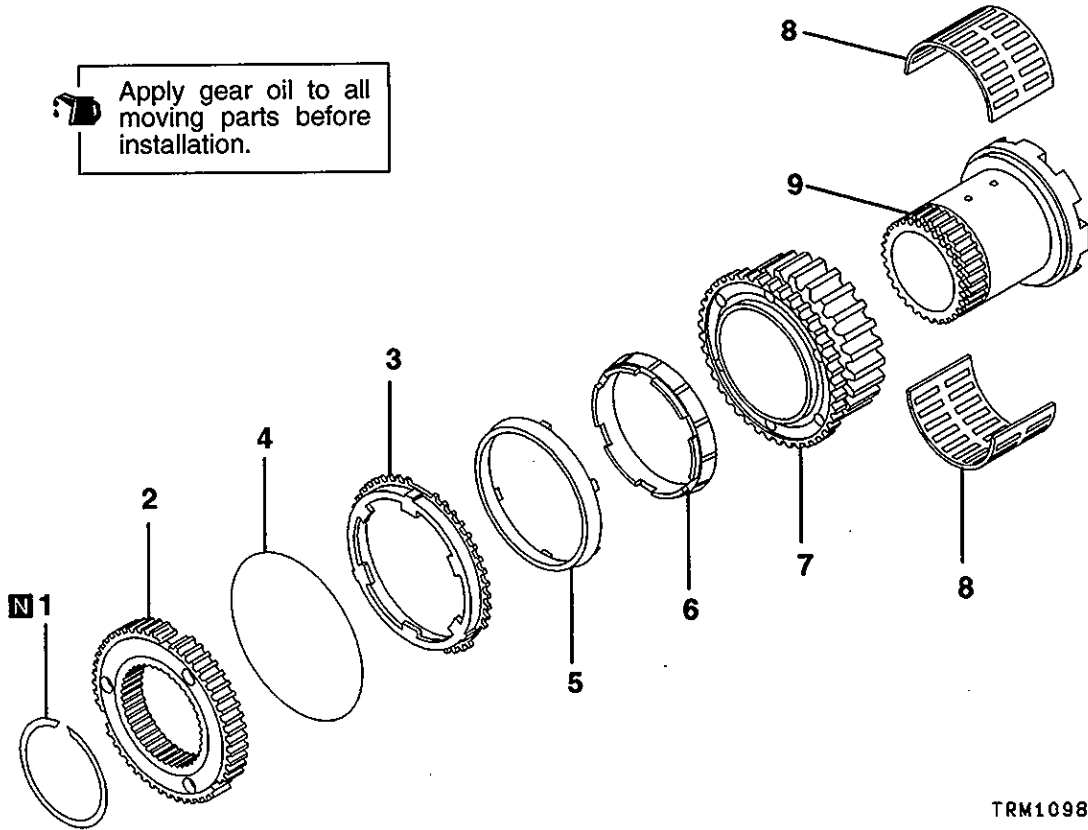

TRM1098

#### Disassembly steps

- ▶C▶ 1. Snap ring
- ▶B▶ 2. 2WD/4WD clutch hub
- ▶A▶ 3. Outer synchronizer ring
- ▶A▶ 4. Synchronizer spring
- ▶A▶ 5. Synchronizer cone
- ▶A▶ 6. Inner synchronizer ring
- ▶A▶ 7. Drive sprocket
- ▶A▶ 8. Needle bearing
- ▶A▶ 9. Front input sleeve

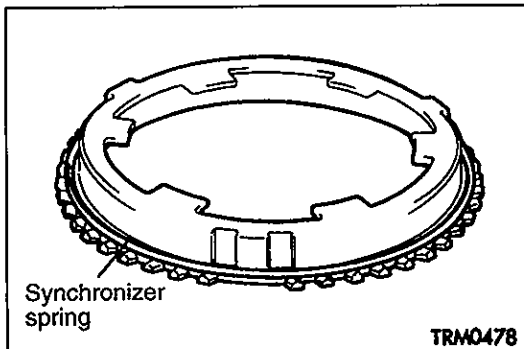

TRM0478

#### REASSEMBLY SERVICE POINTS

##### ▶A◀ SYNCHRONIZER SPRING INSTALLATION

- (1) Securely mount the synchronizer spring on the outer synchronizer ring.

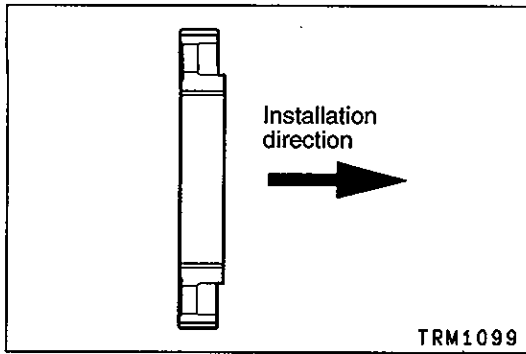
**▶B◀ 2WD/4WD CLUTCH HUB INSTALLATION**

- (1) Install the 2WD/4WD clutch hub in the arrowed direction.

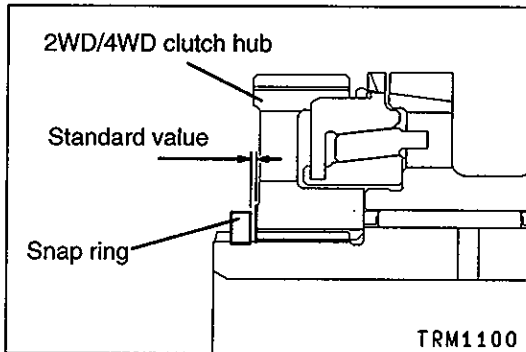
**▶C◀ SNAP RING INSTALLATION**

- (1) Choose and assemble a suitable snap ring to ensure that the 2WD/4WD clutch hub end play is at the standard value.

**Standard value: 0 – 0.08 mm**

# 21. FRONT OUTPUT SHAFT DISASSEMBLY AND REASSEMBLY

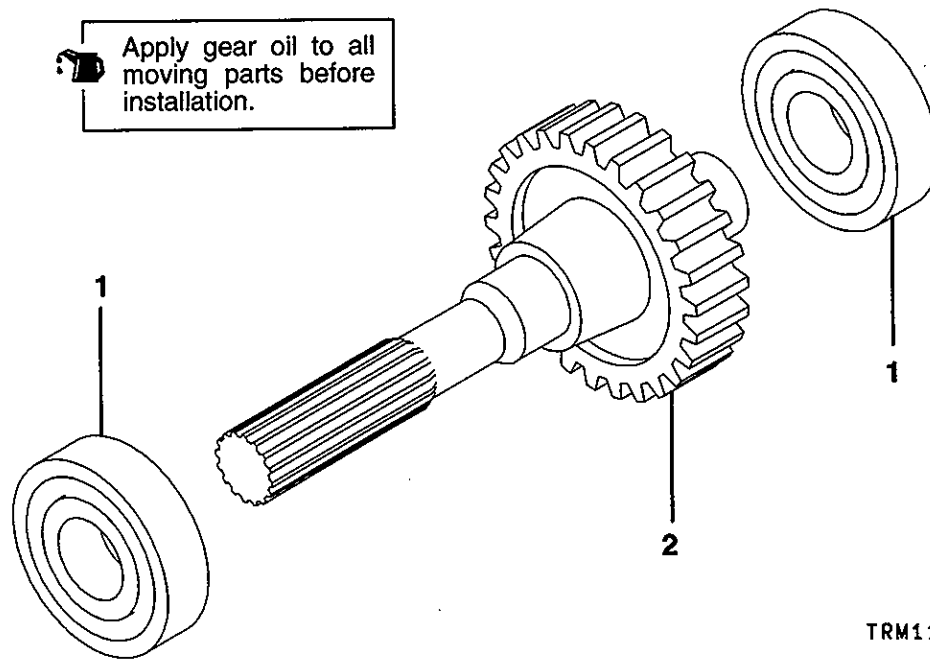

TRM1101

### Disassembly steps

- ◀A▶ ▶A▶
1. Ball bearings
  2. Front output shaft

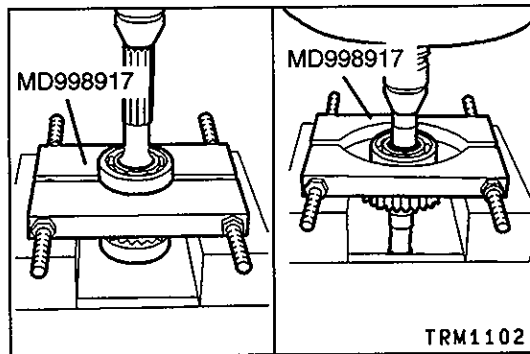

### DISASSEMBLY SERVICE POINT

#### ◀A▶ BALL BEARINGS REMOVAL

- (1) Remove the ball bearings using the indicated special tool.

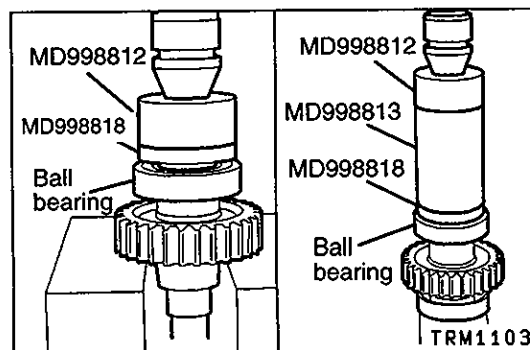

### REASSEMBLY SERVICE POINT

#### ▶A◀ BALL BEARING INSTALLATION

- (1) Install the ball bearings using the indicated special tool.

---

**NOTES**

## 22. TRANSFER CASE PLATE DISASSEMBLY AND REASSEMBLY

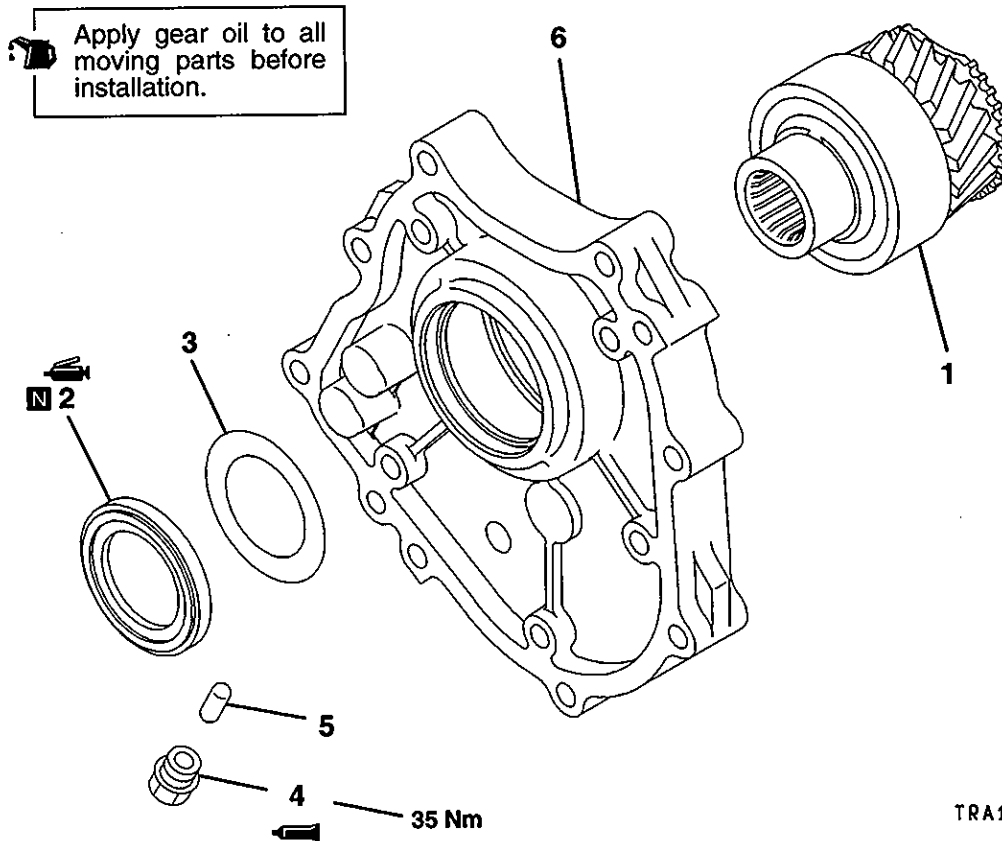

TRA1583

### Disassembly steps

- ▶B◀ 1. Input gear
- ▶B◀ 2. Oil seal
- ▶A◀ 3. Baffle plate
- ▶A◀ 4. Interlock plunger seal bolt
- ▶A◀ 5. Interlock plunger
- 6. Transfer case plate

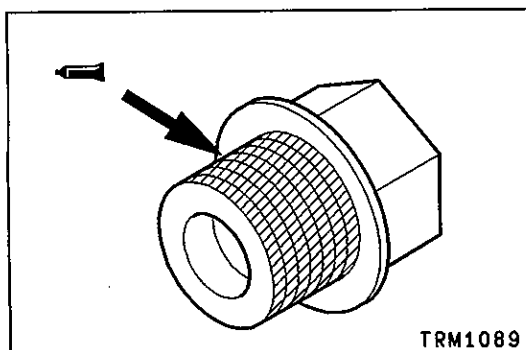

### REASSEMBLY SERVICE POINTS

#### ▶A◀ INTERLOCK PLUNGER SEAL BOLT INSTALLATION (when reused)

- (1) Apply sealant to the threaded area of the seal bolt before tightening to the specified torque.

**Specified sealant:**

**3M ATD Part No. 8660 or equivalent**

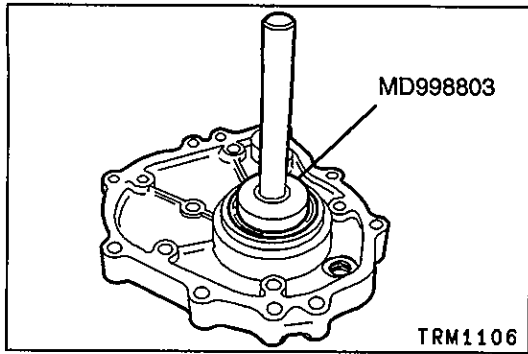
**▶B◀ OIL SEAL INSTALLATION**

- (1) Install the oil seal using the indicated special tool. Following this, apply grease to the lip of the oil seal.

**Specified grease:**

**Mitsubishi genuine grease Part No. MD0101011  
or equivalent**

## 23. INPUT GEAR

### DISASSEMBLY AND REASSEMBLY

 Apply gear oil to all moving parts before installation.

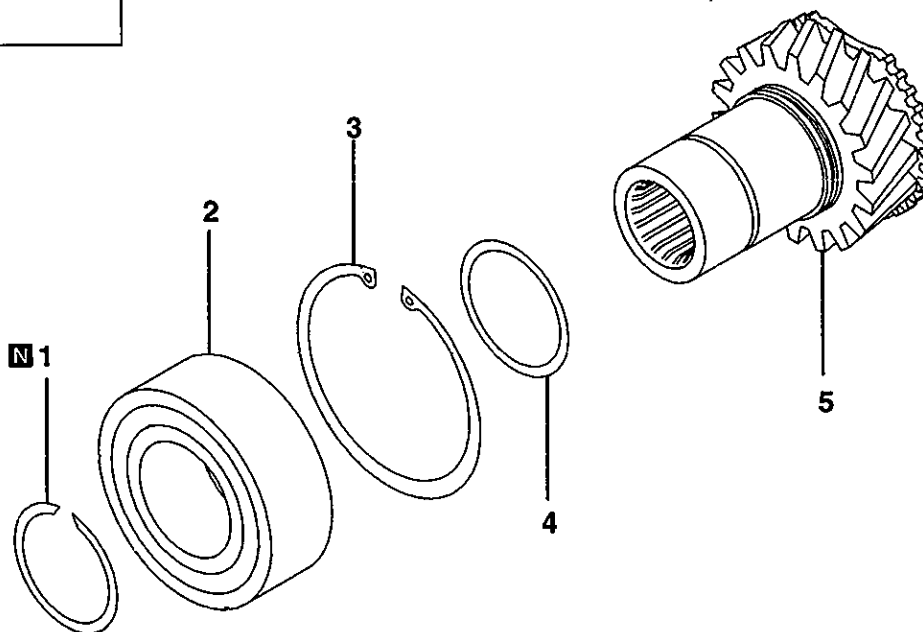

TRA1763

#### Disassembly steps

- ◀A▶
- ▶C▶ 1. Snap ring
  - ▶B▶ 2. Bearing
  - ▶A▶ 3. Snap ring

- 4. Spacer
- 5. Input gear

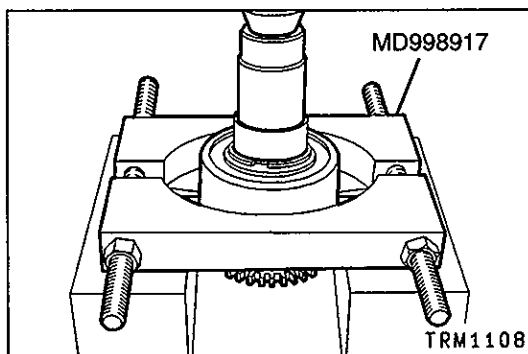

#### DISASSEMBLY SERVICE POINT

##### ◀A▶ BEARING REMOVAL

- (1) Remove the bearing using the indicated special tool.

##### Caution

- Do not allow the special tool to contact the spacer.

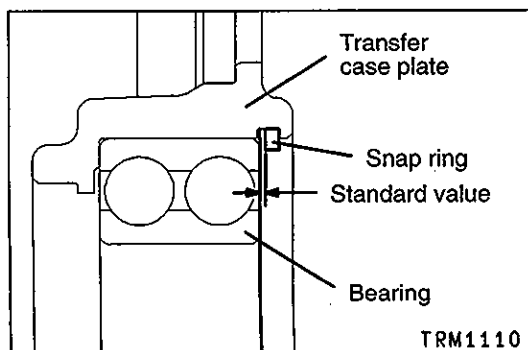

#### REASSEMBLY SERVICE POINTS

##### ▶A▶ SNAP RING SELECTION

- (1) Install the bearing in the transfer case plate.
- (2) Choose and assemble a suitable snap ring to ensure that the input gear end play is at the standard value.

**Standard value: 0 – 0.06 mm**

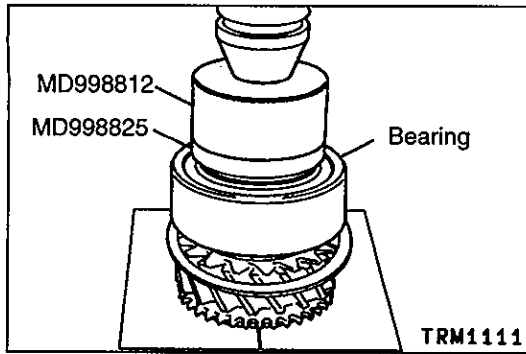
**▶B◀ BEARING INSTALLATION**

- (1) Install the bearing using the indicated special tool.

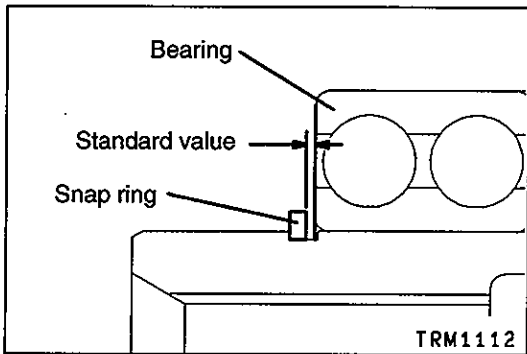
**▶C◀ SNAP RING INSTALLATION**

- (1) Choose and assemble a suitable snap ring to ensure that the input gear bearing clearance is at the standard value.

**Standard value: 0 – 0.06 mm**



# 24. REAR OUTPUT SHAFT DISASSEMBLY AND REASSEMBLY

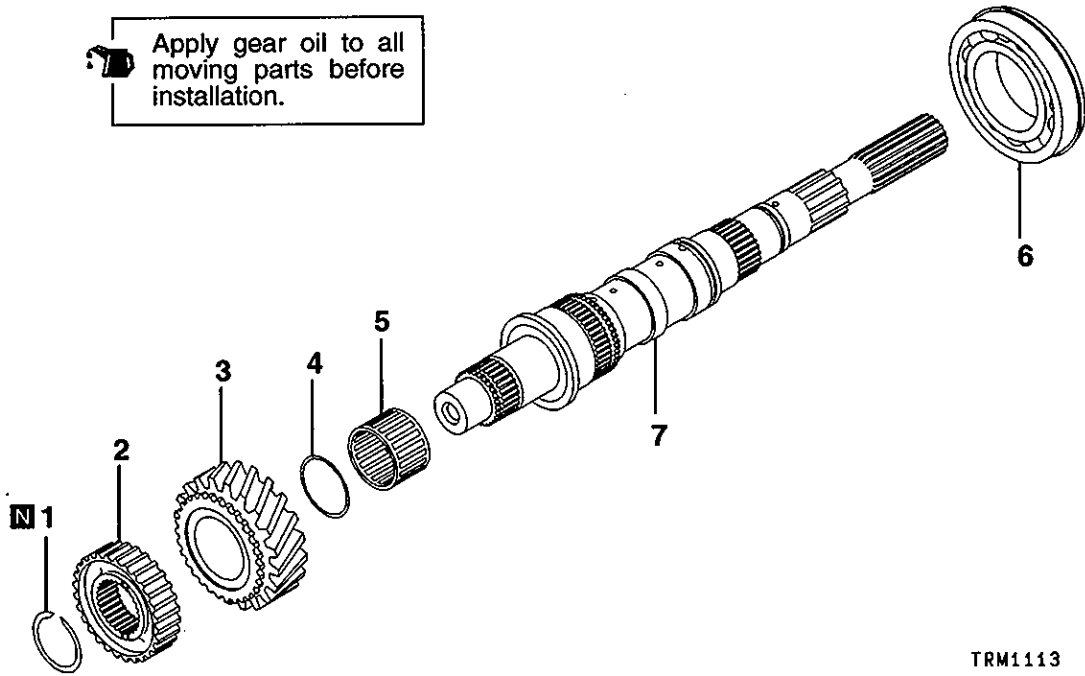

**Disassembly steps**

- ◀C▶ 1. Snap ring
- ◀B▶ 2. Hi-Lo clutch hub
- 3. Low speed gear
- 4. Bearing spacer
- 5. Needle bearing
- ◀A▶ ▶A▶ 6. Center bearing
- 7. Rear output shaft

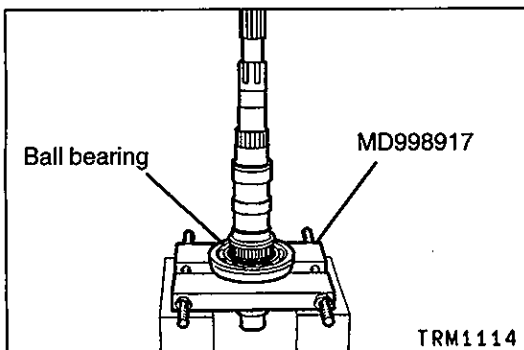

**DISASSEMBLY SERVICE POINT**

◀A▶ **CENTER BEARING REMOVAL**

- (1) Remove the center bearing using the indicated special tool.

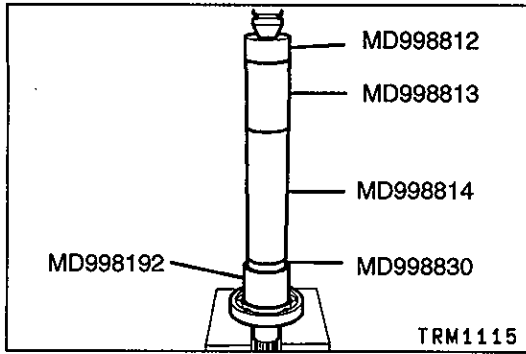
**REASSEMBLY SERVICE POINT****▶A◀ CENTER BEARING INSTALLATION**

- (1) Install the center bearing using the indicated special tool.

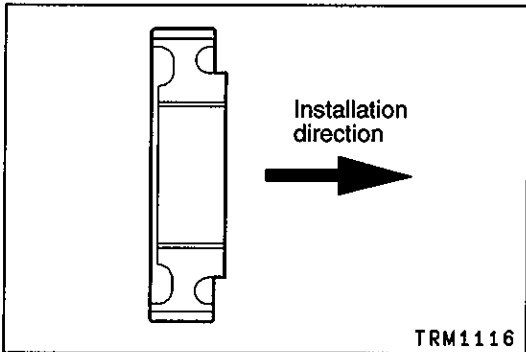
**▶B◀ HI-LO CLUTCH HUB INSTALLATION**

- (1) Install the Hi-Lo clutch hub in the direction indicated by arrow.

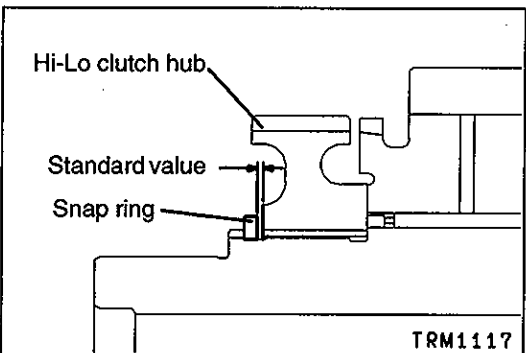
**▶C◀ SNAP RING INSTALLATION**

- (1) Choose and assemble a suitable snap ring to ensure that the Hi-Lo clutch hub end play is at the standard value.

**Standard value: 0 – 0.08 mm**