ENGINE LUBRICATION

ENGINE LUBRICATION

CONTENTS

12109000051

GENERAL INFORMATION	2	Engine Oil Replacement	3
LUBRICANTS	3	Oil Filter Replacement	4
SPECIAL TOOLS	3	ENGINE OIL COOLER <4D56>	6
ON-VEHICLE SERVICE	3		
Engine Oil Check	3		

GENERAL INFORMATION

12100010053

The lubrication method is a fully force-fed, full-flow filtration type.

The corrugate fin type of engine oil cooler have been adopted, and installed forward of the radiator. <4D56>

Items	4G63	4G64	4D56
Oil pump type	Involute gear type	Involute gear type	Trochoid type
Drive method	Timing belt	Timing belt	Crankshaft

ENGINE OILS**Health Warning**

Prolonged and repeated contact with mineral oil will result in the removal of natural fats from the skin, leading to dryness, irritation and dermatitis. In addition, used engine oil contains potentially

harmful contaminants which may cause skin cancer. Adequate means of skin protection and washing facilities must be provided.

Recommended Precautions

The most effective precaution is to adapt working practices which prevent, as far as practicable, the risk of skin contact with mineral oils, for example by using enclosed systems for handling used engine oil and by degreasing components, where practicable, before handling them.

Other precautions:

- Avoid prolonged and repeated contact with oils, particularly used engine oils.
- Wear protective clothing, including impervious gloves where practicable.
- Avoid contaminating clothes, particularly underpants, with oil.
- Do not put oily rags in pockets, the use of overalls without pockets will avoid this.
- Do not wear heavily soiled clothing and oil-impregnated foot-wear. Overalls must be cleaned regularly and kept separate from personal clothing.

- Where there is a risk of eye contact, eye protection should be worn, for example, chemical goggles or face shields; in addition an eye wash facility should be provided.
- Obtain First Aid treatment immediately for open cuts and wounds.
- Wash regularly with soap and water to ensure all oil is removed, especially before meals (skin cleansers and nail brushes will help). After cleaning, the application of preparations containing lanolin to replace the natural skin oils is advised.
- Do not use petrol, kerosine, diesel fuel, gas oil, thinners or solvents for cleaning skin.
- Use barrier creams, applying them before each work period, to help the removal of oil from the skin after work.
- If skin disorders develop, obtain medical advice without delay.

LUBRICANTS

12100040076

Items		4G63	4G64	4D56	4D56-Turbo
Engine oil API classification		SG or higher	SG or higher	CD or higher	CD or higher
Engine oil quantity ℓ	Oil filter	0.3	0.3	0.8	0.8
	Oil cooler	–	–	0.4	0.4
	Total	4.3	4.3	6.2	6.5

SPECIAL TOOLS

12100060065

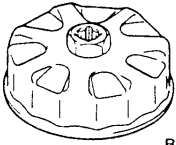
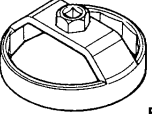
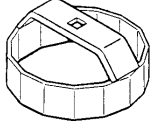
Tool	Number	Name	Use
 B991396	MB991396	Oil filter wrench	Removal and installation of engine oil filter (When using the oil filter of MD135737) <4G6>
 B991610	MB991610	Oil filter wrench	Removal and installation of engine oil filter (When using the oil filter of MD136466) <4G6>
 H061590	MH061590	Oil filter wrench	Removal and installation of engine oil filter (When using the oil filter of MD069782 or MD326489) <4D56>

ON-VEHICLE SERVICE

12100090057

ENGINE OIL CHECK

1. Check the engine oil using the oil level gauge.
2. Check that the oil is not excessively dirty, that there is no coolant or petrol mixed in, and that it has sufficient viscosity.

ENGINE OIL REPLACEMENT

12100100071

1. Start the engine and allow it to warm up until the temperature of the coolant reaches 80°C to 90°C.
2. Remove the engine oil filler cap.
3. Remove the drain plug to drain oil.

Caution

Use care as oil could be hot.

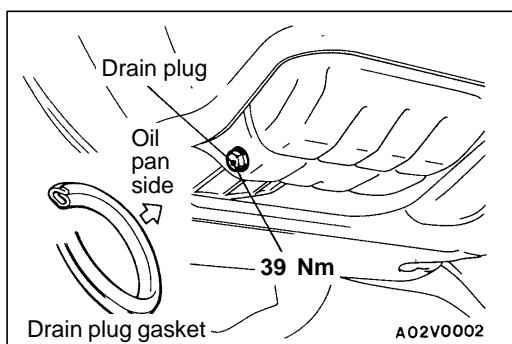

- Install a new drain plug gasket so that it faces in the direction shown in the illustration, and then tighten the drain plug to the specified torque.

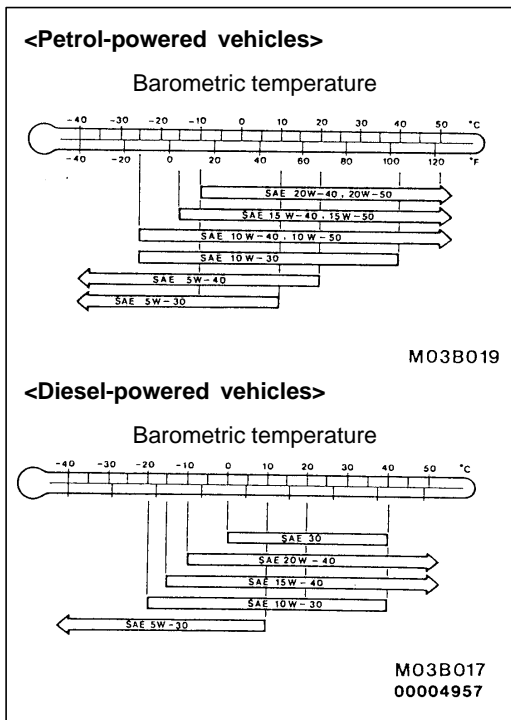

- Refill with specified quantity of oil.

Specified Engine Oil (API classification):

<4G63, 4G64> SG or higher

<4D56> CD or higher

Total quantity (Includes volume inside oil filter and oil cooler):

<4G63> 4.3 l

<4G64> 4.3 l

<4D56> 6.2 l

<4D56-Turbo> 6.5 l

- Install the engine oil filler cap.
- Check oil level.

OIL FILTER REPLACEMENT

12100110067

- Start the engine and allow it to warm up until the temperature of the coolant reaches 80°C to 90°C.
- Remove the engine oil filler cap.
- Remove the under cover.
- Remove the drain plug to drain oil.

Caution

Use care as oil could be hot.

- Remove the air cleaner, and cover the alternator with a rag so that oil will not get on the alternator. <4D56>
- Use the following tools to remove the engine oil filter.
 - MB991396 or equivalent (when using the oil filter of MD135737) <4G6>
 - MB991610 or equivalent (when using the oil filter of MD136466) <4G6>
 - MH061590 or equivalent (when using the oil filter of MD069782 or MD326489) <4D56>
 - Commercial tool (other vehicles than above)
- Clean the filter bracket side mounting surface.

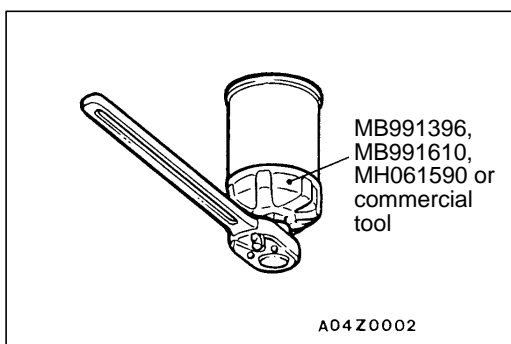

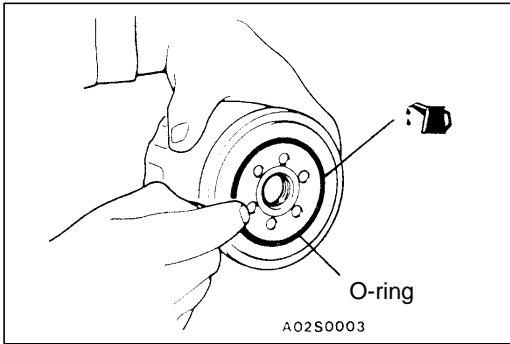

8. Apply a small amount of engine oil to the O-ring of the new oil filter.
9. Install the oil filter.

NOTE

Tightening torque:

<4G6> When using the oil filter of MD135737:

14 Nm

<4G6> When using the oil filter of MD325714 or MD332687: 16 Nm

<4G6> When using the oil filter of MD136466 or MD322508: 17 Nm

<4D56> When using the oil filter of MD069782 or MD184086: 20 Nm

<4D56> When using the oil filter of MD326489:
22 Nm

10. Install the drain plug and refill the engine oil. (Refer to P.12-3, Engine Oil Replacement.)
11. Race the engine 2-3 times, and check to be sure that no engine oil leaks from installation section of the oil filter.

ENGINE OIL COOLER <4D56>

REMOVAL AND INSTALLATION

Pre-removal Operation

- Radiator Grille Removal

Post-installation Operation

- Radiator Grille Installation
- Engine Oil Checking and Supplying (Refer to P.12-3.)

<M/T>

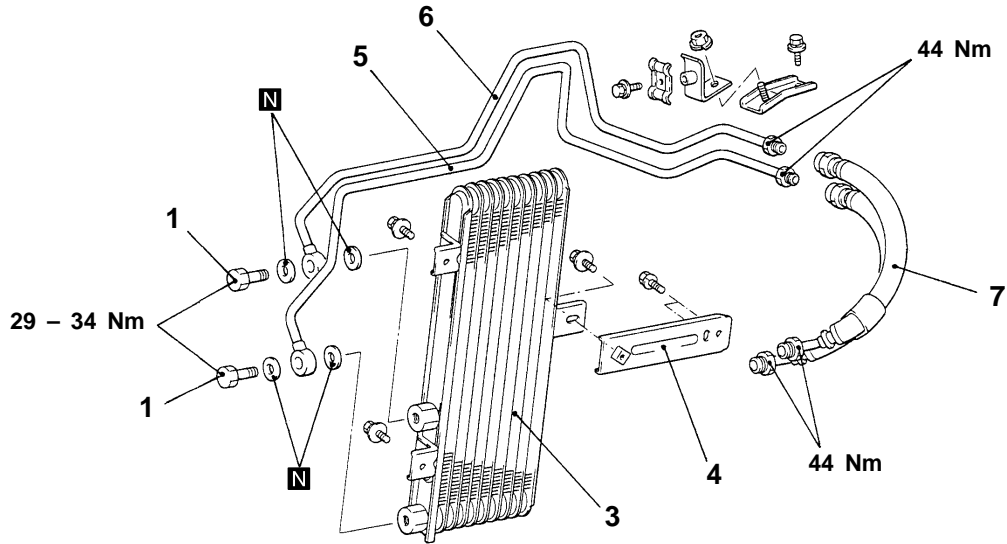

04V0006

<A/T>

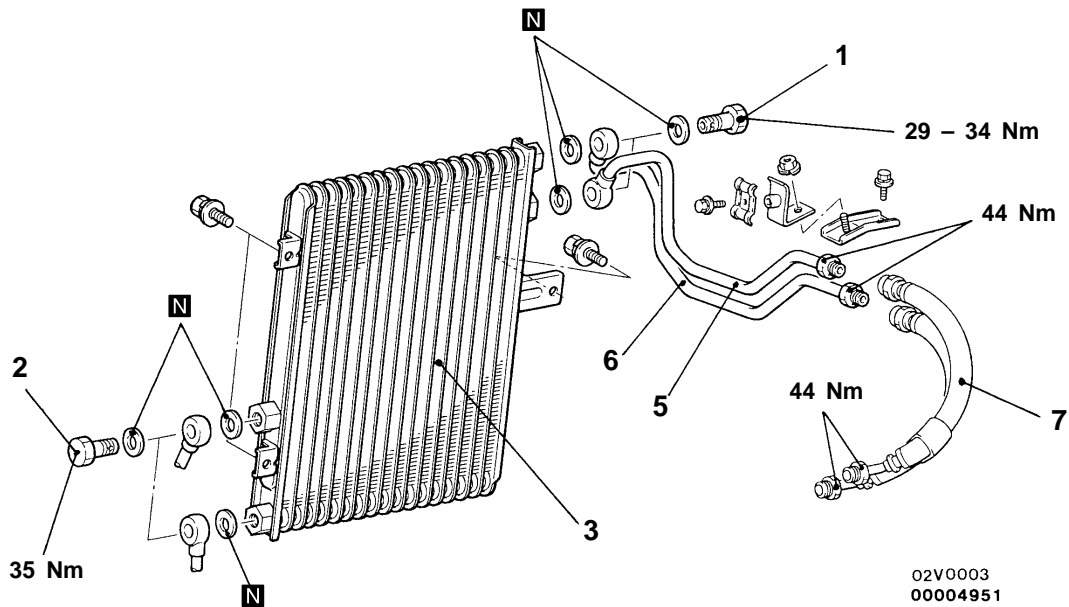

02V0003
00004951

Oil cooler removal steps



1. Eye bolts (for engine oil cooler)
2. Eye bolts (for A/T oil cooler) <A/T>
3. Oil cooler assembly
4. Stay <M/T>

Oil cooler tube and hose removal steps



1. Eye bolts (for engine oil cooler)
5. Oil return tube
6. Oil feed tube
- Engine oil filter (Refer to P.12-4.)
7. Oil cooler hose assembly

REMOVAL SERVICE POINT**◀A▶ EYE BOLTS REMOVAL****Caution**

Be sure to hold the weld nut of the oil cooler while loosening the eye bolt.

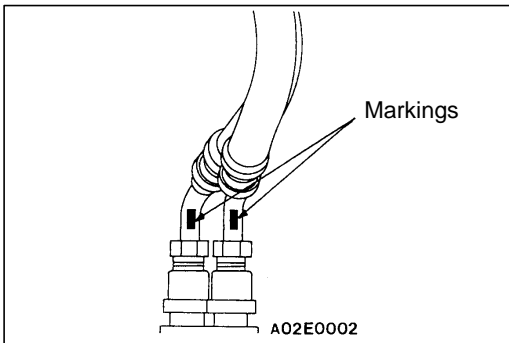
**INSTALLATION SERVICE POINTS****▶A◀ OIL COOLER HOSE ASSEMBLY (ENGINE SIDE) INSTALLATION**

Install the oil cooler hose assembly with the markings facing upwards.

▶B◀ EYE BOLT INSTALLATION

1. Provisionally tighten the eye bolt.
2. Align the white markings of the oil feed tube and oil return tube with the clamps, and then tighten them provisionally.
3. Tighten eye bolt to the specified torque.

Caution

Be sure to hold the weld nut of the oil cooler while tightening the eye bolt.

4. Tighten the clamp mounting bolt securely.

NOTES



SERVICE BULLETIN

QUALITY INFORMATION ANALYSIS
OVERSEAS SERVICE DEPT. MITSUBISHI MOTORS CORPORATION

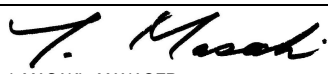
SERVICE BULLETIN		No.: MSB-00E12-502	
		Date: 2001-07-11	
Subject: CORRECTION OF DESCRIPTIONS CONCERNING OIL FILTER WRENCH		<Model> (EC)GALANT(EA0) (EC)SPACE STAR (DG0A) (EC)SPACE RUNNER/SPACE WAGON (N60,N80,N90) (EC)PAJERO SPORT (K80W,K90W) (EC)L200(K60,K70)	<M/Y> 97-99 99-99 99-99 99-99 97-97
Group: ENGINE LUBRICATION		Draft No.: 00AL092714	
CORRECTION	INTERNATIONAL CAR ADMINISTRATION OFFICE	 J. MASAKI - MANAGER TECHNICAL SERVICE PLANNING	

1. Description:

This Service Bulletin informs you that correction has been made of descriptions concerning the oil filter wrench.

2. Applicable Manuals:

Manual	Pub. No.	Language	Page(s)
'97 GALANT Workshop Manual chassis	PWDE9611	(English)	12-3, 4, 5
	PWDS9612	(Spanish)	
	PWDF9613	(French)	
	PWDG9614	(German)	
	PWDD9615	(Dutch)	
	PWDW9616	(Swedish)	
'99 GALANT Workshop Manual chassis	PWDE9611-A	(English)	12-2, 4
	PWDS9612-A	(Spanish)	
	PWDF9613-A	(French)	
	PWDG9614-A	(German)	
	PWDD9615-A	(Dutch)	
	PWDW9616-A	(Swedish)	
'99 GALANT Workshop Manual chassis CD-ROM	PWDH9821R	(English)	
	PWDH9821R	(Spanish)	
	PWDH9821R	(French)	
	PWDK9817R	(German)	
	PWDK9817R	(Dutch)	
	PWDK9817R	(Swedish)	

Manual	Pub. No.	Language	Page(s)
'99 SPACE STAR Workshop Manual chassis	CMXE99E1	(English)	12-3, 4, 5
	CMXS99E1	(Spanish)	
	CMXF99E1	(French)	
	CMXG99E1	(German)	
	CMXD99E1	(Dutch)	
	CMXW99E1	(Swedish)	
	CMXI99E1	(Italian)	
'99 SPACE RUNNER/SPACE WAGON Workshop Manual chassis	PWDE9803	(English)	12-3, 5
	PWDS9804	(Spanish)	
	PWDF9805	(French)	
	PWDG9806	(German)	
	PWDD9807	(Dutch)	
	PWDW9808	(Swedish)	
'99 SPACE RUNNER/SPACE WAGON Workshop Manual chassis CD-ROM	PWDH9816R	(English)	
	PWDH9816R	(Spanish)	
	PWDH9816R	(French)	
	PWDK9817R	(German)	
	PWDK9817R	(Dutch)	
	PWDK9817R	(Swedish)	
'99 PAJERO SPORT Workshop Manual chassis	PWJE9812	(English)	12-3, 4, 5
	PWJS9813	(Spanish)	
	PWJF9814	(French)	
	PWJG9815	(German)	
'99 PAJERO SPORT Workshop Manual chassis CD-ROM	PWJT9818R	(English)	
	PWJT9818R	(Spanish)	
	PWJT9818R	(French)	
	PWJT9818R	(German)	
'97 L200 Workshop Manual chassis	PWTE96E1	(English)	12-3, 4
	PWTS96E1	(Spanish)	
	PWTF96E1	(French)	
	PWTG96E1	(German)	

LUBRICANTS

12100040151

Items		4G6	6A1	4D6
Engine oil (API classification)		SG or higher	SG or higher	CD or higher
Engine oil quantity <i>l</i>	Oil filter	0.3	0.3	0.8
	Oil cooler	-	0.1	0.3
	Total	4.3	4.3	5.1

SPECIAL TOOLS

12100100163

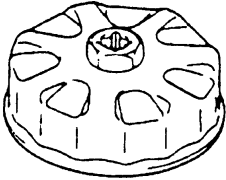
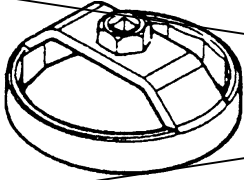
Tool	Number	Name	Use
 B991396	MB991396	Oil filter wrench	Removal and installation of engine oil filter (when using the oil filter of MD135737) <4G6>
 B991610	MB991610	Oil filter wrench	Removal and installation of engine oil filter (When using the oil filter of MD136466) <6A1>

<Deleted>

ON-VEHICLE SERVICE

12100090095

ENGINE OIL CHECK

1. Pull out the level gauge slowly and check that the oil level is in the illustrated range.
2. Check that the oil is not excessively dirty, that there is no coolant or gasoline mixed in, and that it has sufficient viscosity.

ENGINE OIL REPLACEMENT

12100100163

1. Start the engine and allow it to warm up until the temperature of the coolant reaches 80°C to 90°C.
2. Remove the engine oil filler cap.
3. Remove the drain plug to drain oil.

Caution

Use care as oil could be hot.

4. Install a new drain plug gasket so that it faces in the direction shown in the illustration, and then tighten the drain plug to the specified torque.

NOTE

Install the drain plug gasket so it faces in the direction shown in the illustration.

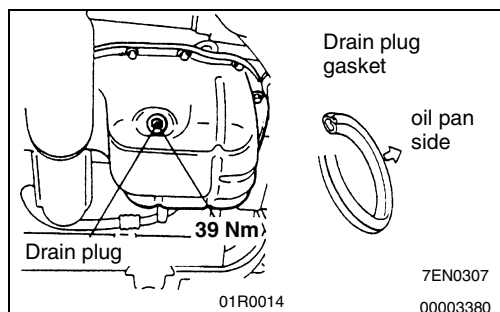

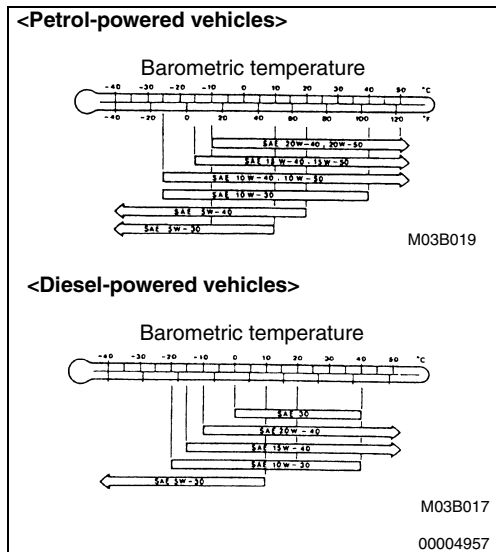

5. Refill with specified quantity of oil

Specified Engine Oil (API classification):

<4G6, 6A1> SG or higher

<4D6> CD or higher

Total quantity (includes volume inside oil filter and oil cooler):

<4G6, 6A1> 4.3 ℓ

<4D6> 5.1 ℓ

6. Install the engine oil filler cap.

7. Check oil level.

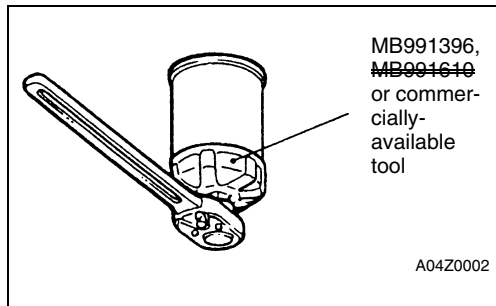

OIL FILTER REPLACEMENT

12100110159

1. Start the engine and allow it to warm up until the temperature of the coolant reaches 80°C to 90°C.
2. Remove the engine oil filler cap.
3. Remove the drain plug to drain oil.

Caution

Use care as oil could be hot.

4. Use the respective tool in the following table to remove the engine oil filter.

Caution

For vehicles with 6A1 engine, the oil which is still inside the oil filter may overflow from the oil guide groove and get onto the starter motor. To prevent this, the oil inside the filter should be gradually removed while removing the oil filter.

5. Clean the filter bracket side mounting surface.

6. Apply a small amount of engine oil to the O-ring of the new oil filter.
7. Once the O-ring of the oil filter is touching the flange, use the respective tool in the following table to tighten to the specified torque.
8. Install the drain plug and refill engine oil. (Refer to Engine Oil Replacement on P.12-3.)
9. Race the engine 2-3 times, and check to be sure that no engine oil leaks from installation section of the oil filter.

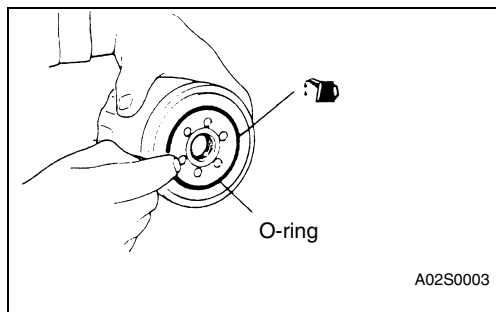

<Deleted>

Number	Engine	Tool	Tightening torque
MD135737	4G6	MB991396 or equivalent tool	Approx. 1 turn (14 Nm)
MD136466	6A1	MB991610 or equivalent tool	Approx. 3/4 turn (17 Nm)
MD336080	4D6	Commercially-available tool	Approx. 1-1/8 turns (20 Nm)

<Correct>

Commercially-available tool

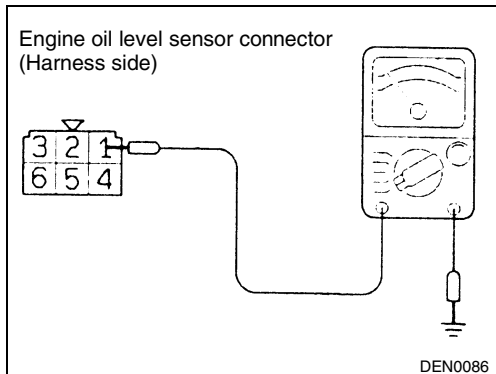
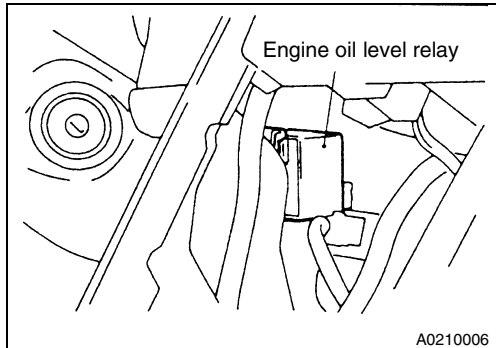

OIL LEVEL WARNING SYSTEM

12100200047

1. Check that the proper amount of oil has been filled.
2. When the ignition switch is turned to ON (do not start the engine), check that the oil level warning lamp illuminates.

NOTE

If the oil level warning lamp does not illuminate, the cause is probably a blown lamp, or a malfunction in the relay.

3. When the engine is started, check that the oil level warning lamp turns off.

If the oil level warning lamp will not go out, disconnect the connector of the oil level relay and measure the voltage of the No. 1 terminal on the harness side of the connector while idling the engine in order to confirm that it is the same as the battery voltage.

NOTE

- (1) If the voltage at the connector is the same as the battery voltage, the problem is probably a malfunction of either the oil level relay or the oil level sensor.
- (2) If the voltage at the connector is lower than the battery voltage, the problem is probably a malfunction of either the alternator or the wiring harness.

4. Disconnect the oil level sensor connector. Check that the oil level warning lamp illuminates after approximately 40 seconds.

If the oil level warning lamp does not illuminate, replace the oil level relay.

<Deleted>

GENERAL

OUTLINE OF CHANGE

4G64-GDI engines have been introduced. Accordingly, service procedures have been added as follows.

LUBRICANTS

Items	4G64	
Engine oil (API classification)	SG or higher	
Engine oil quantity ℓ	Oil filter	0.3
	Total	4.3

SPECIAL TOOL

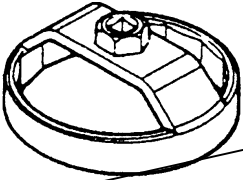
Tool	Number	Name	Use
 <small>B991610</small>	MB991610	Oil filter wrench	Removal and installation of engine oil filter (When using the oil filter of MD136466 and MD356000)

<Deleted>

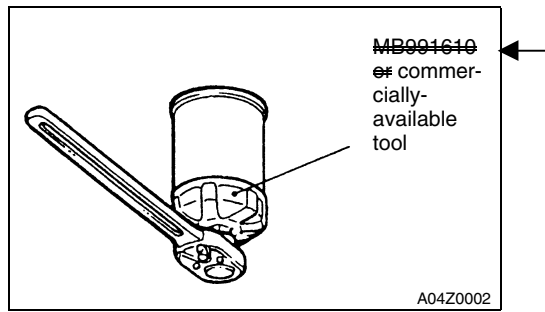

<Deleted>

OIL FILTER REPLACEMENT

1. Start the engine and warm it up until coolant reaches 80°C to 90°C.
2. Remove the engine oil filler cap.
3. Remove the drain plug to drain oil.

Caution

Use care as oil could be hot.

4. Remove the under cover.
5. Use the respective tool in the following table to remove the engine oil filter.
6. Clean the filter bracket side mounting surface.

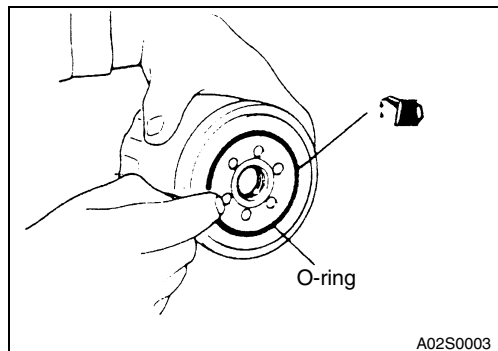

7. Apply a small amount of engine oil to the O-ring of the new oil filter.
8. Once the O-ring of the oil filter is touching the flange, use the respective tool in the following table to tighten to the specified torque.
9. Install the drain plug and refill engine oil. (Refer to Engine Oil Replacement on P.12-3.)
10. Race the engine 2-3 times, and check to be sure that no engine oil leaks from installation section of the oil filter.

Number	Tool	Tightening torque
MD136466	MB001610 or equivalent tool	Approx. 3/4 turns (17 Nm)
MD322508	Commercially-available tool	Approx. 3/4 turns (17 Nm)
MD356000	MB001610 or equivalent tool	Approx. 3/4 turns (14 Nm)

<Incorrect>

<Correct>

Commercially-available tool

LUBRICANTS

12100040243

Items		Engine oil (API classification)	Quantity ℓ
Oil filter		SG or higher	0.3
Total quantity	GDI		3.8
	MPI		3.3

SPECIAL TOOLS

12100060140

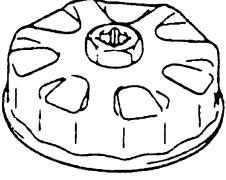
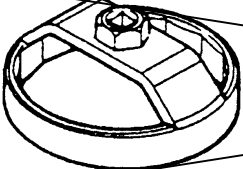
Tool	Number	Name	Use
 B991396	MB991396	Oil filter wrench	Removal and installation of engine oil filter (when using the oil filter of MD135737)
 B991610	MB991610	Oil filter wrench	Removal and installation of engine oil filter (When using the oil filter of MD136466)

<Deleted>

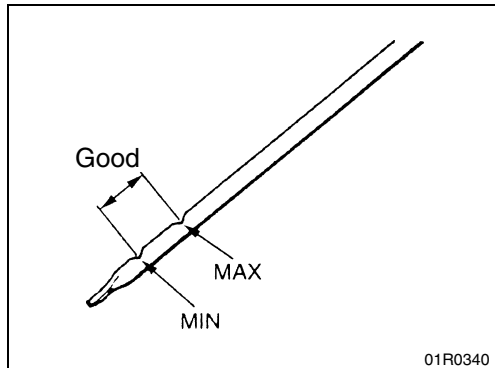

ON-VEHICLE SERVICE
ENGINE OIL INSPECTION

12100090125

1. Pull out the level gauge slowly and check that the oil level is in the illustrated range.
2. Check that the oil is not excessively dirty, that there is no coolant or gasoline mixed in, and that it has sufficient viscosity.

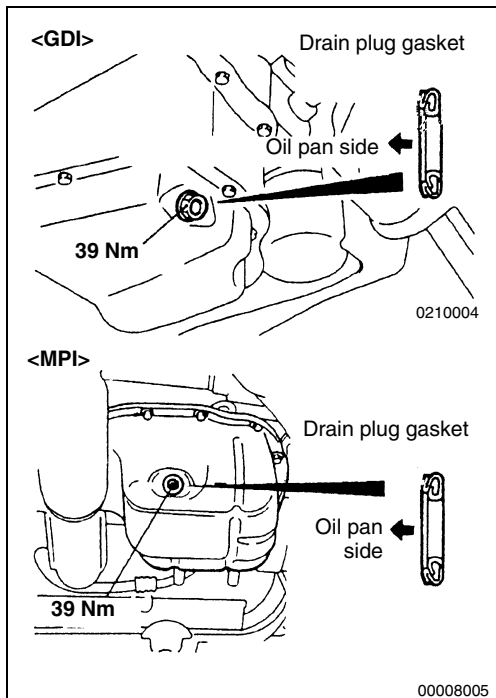

ENGINE OIL REPLACEMENT

12100100255

1. Start the engine and allow it to warm up until the temperature of the coolant reaches 80°C to 90°C.
2. Remove the engine oil filler cap.
3. Remove the drain plug to drain oil.

Caution

Use care as oil could be hot.

4. Install a new drain plug gasket so it faces in the direction shown in the illustration, and then tighten the drain plug to the specified torque.

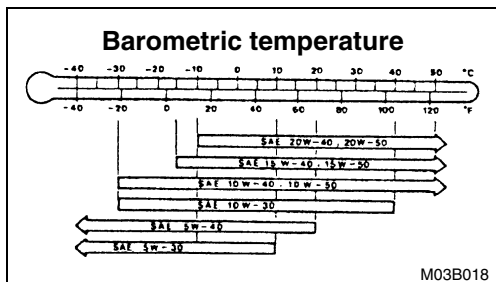

5. Refill with specified quantity of oil.

Specified Engine Oil (API classification): SG or higher
Total quantity (Includes volume inside oil filter):

<GDI> 3.8 l

<MPI> 3.3 l

6. Install the engine oil filler cap.
7. Check oil level.

<Deleted>

OIL FILTER REPLACEMENT

12100110241

1. Start the engine and allow it to warm up until the temperature of the coolant reaches 80°C to 90°C.
2. Remove the engine oil filler cap.
3. Remove the drain plug to drain oil.

Caution

Use care as oil could be hot.

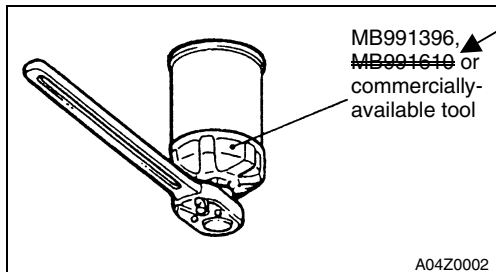

4. Use the following tools to remove the engine oil filter from the underside of the vehicle.

MB991396 or equivalent (When using the oil filter of MD135737)

MB991610 or equivalent (When using the oil filter of MD136466)

Commercial tool (When using the oil filter except MD135737 and MD136466)

5. Clean the bracket side mounting surface.

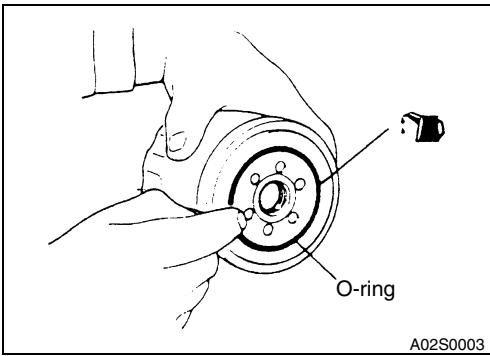

6. Apply a small amount of engine oil to the O-ring of a new oil filter
7. Once the O-ring of the oil filter is touching the flange, use the respective tool in the following table to tighten the oil filter to the specified torque.
8. Install the drain plug and refill engine oil. (Refer to Engine Oil Replacement in P.12-4.)
9. Race the engine 2-3 times, and check to be sure that no engine oil leaks from installation section of the oil filter.

Number	Tool	Tightening torque
MD135737	MB991396 or equivalent tool	Approx. 1 turn (14 Nm)
MD136466	MB991610 or equivalent tool	Approx. 3/4 turn (17 Nm)
MD322508	Commercially-available tool	
MD325714 and MD332687		Approx. 3/4 turn (16 Nm)

<Deleted>

SERVICE SPECIFICATIONS

Item		Standard value	Limit
Oil pressure kPa	at idle	29 or more	-
	at 3,500 r/min	294 – 686	-

SEALANT

Item	Specified sealant	Remark
Oil pressure switch	3M ATD Part No. 8660 or equivalent	-

LUBRICANTS

Items		Specifications
Engine oil (API classification)		SG or higher
Engine oil quantity ℓ	Oil filter	0.3
	Total	3.8

SPECIAL TOOLS

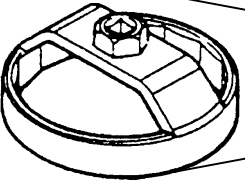
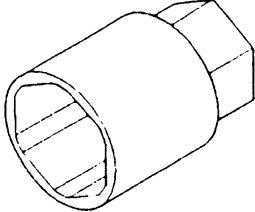
Tool	Number	Name	Use
 B991610	MB991610	Oil filter wrench	Removal and installation of engine oil filter (When using the oil filter of MD136466 and MD356000)
	MD998054	Oil pressure switch wrench	Removal and installation of oil pressure switch

<Deleted>

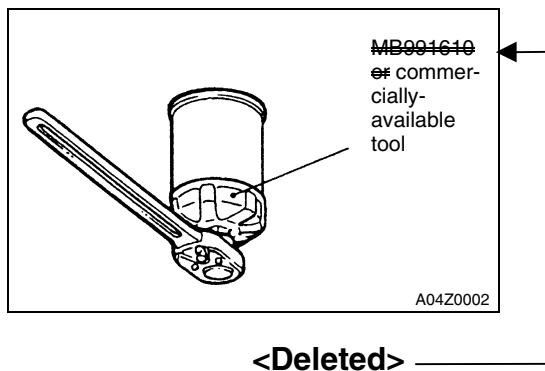

OIL FILTER REPLACEMENT

1. Start the engine and allow it to warm up until the temperature of the coolant reaches 80°C to 90°C.
2. Remove the engine oil filler cap.
3. Remove the drain plug to drain oil.

Caution
Use care as oil could be hot.

4. Remove the under cover.
5. Use the respective tool in the following table to remove the engine oil filter.
6. Clean the filter bracket side mounting surface.

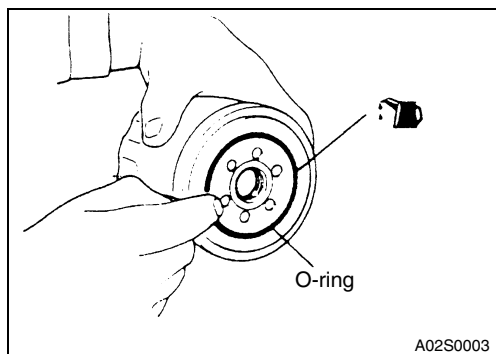

7. Apply a small amount of engine oil to the O-ring of the new oil filter.
8. Once the O-ring of the oil filter is touching the flange, use the respective tool in the following table to tighten to the specified torque.
9. Install the drain plug and refill engine oil. (Refer to Engine Oil Replacement on P.12-3.)
10. Race the engine 2-3 times, and check to be sure that no engine oil leaks from installation section of the oil filter.

Number	Tool	Tightening torque
MD136466	MB001610 or equivalent tool	Approx. 3/4 turn (17 Nm)
MD322508	Commercially-available tool	Approx. 3/4 turn (17 Nm)
MD356000	MB001610 or equivalent tool	Approx. 3/4 turn (14 Nm)

<Incorrect>

<Correct>

Commercially-available tool

LUBRICANTS

12100040304

Items		6G7	4D5
Engine oil API classification		SG or higher	CD or higher
Engine oil quantity <i>ℓ</i>	Oil filter	0.3	0.8
	Oil cooler	-	0.4
	Total	4.5	6.5

SPECIAL TOOLS

12100060171

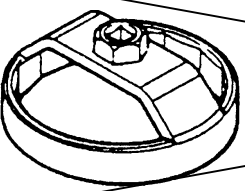
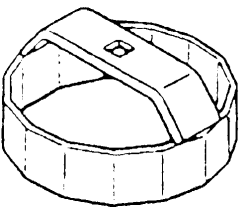
Tool	Number	Name	Use
 8991610	MB991610	Oil filter wrench	Removal and installation of engine oil filter (When using the oil filter of MD352626) <6G7>
 H061590	MH061590	Oil filter wrench	Removal and installation of engine oil filter (When using the oil filter of MD069782 or MD326489) <4D5>

<Deleted>

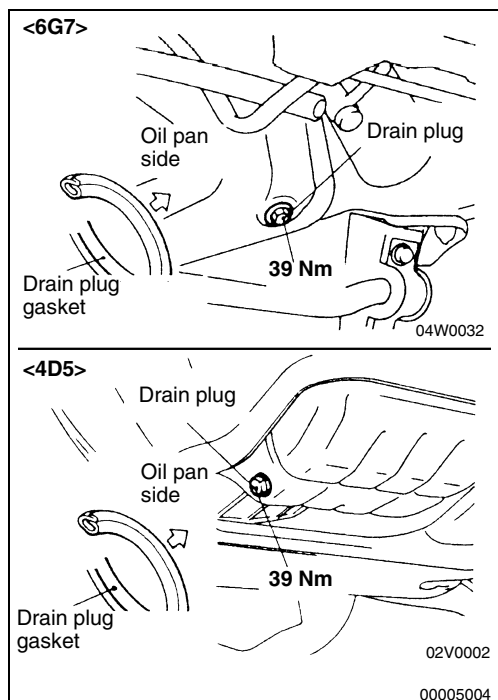

ON-VEHICLE SERVICE
ENGINE OIL CHECK

12100090149

1. Check the engine oil using the oil level gauge.
2. Check that the oil is not excessively dirty, that there is no coolant or petrol mixed in, and that it has sufficient viscosity.

ENGINE OIL REPLACEMENT

12100100286

1. Start the engine and allow it to warm up until the temperature of the coolant reaches 80°C to 90°C.
2. Remove the engine oil filler cap.
3. Remove the drain plug to drain oil.

Caution

Use care as oil could be hot.

4. Install a new drain plug gasket so that it faces in the direction shown in the illustration, and then tighten the drain plug to the specified torque.

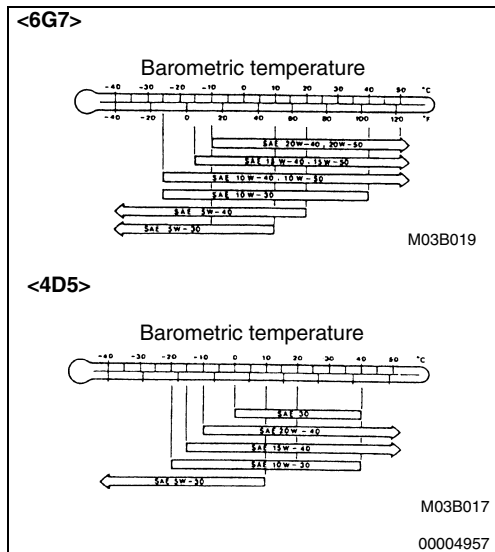

5. Refill with specified quantity of oil.

Specified Engine Oil (API classification):

<6G7> SG or higher

<4D5> CD or higher

Total quantity (includes volume inside oil filter and oil cooler):

<4G7> 4.5 ℓ

<4D5> 6.5 ℓ

6. Install the engine oil filler cap.

7. Check oil level.

OIL FILTER REPLACEMENT

12100110272

1. Start the engine and allow it to warm up until the temperature of the coolant reaches 80°C to 90°C.
2. Remove the engine oil filler cap.
3. Remove the under cover.
4. Remove the drain plug to drain oil

Caution

Use care as oil could be hot.

5. Remove the air cleaner, and cover the alternator with a rag so that oil will not get on the alternator. <4D56>

6. Use the respective tool in the following table to remove the engine oil filter.
7. Clean the filter bracket side mounting surface and ensure the old O-ring has been removed.

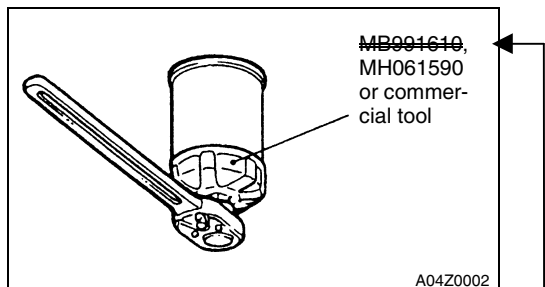

<Deleted>

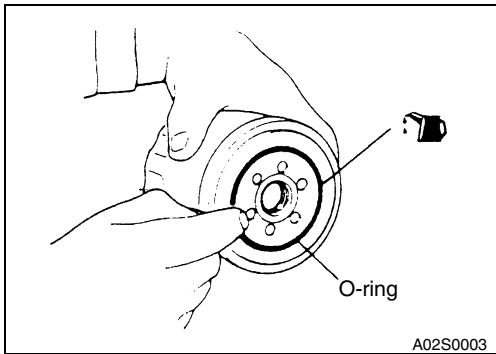

8. Apply a small amount of engine oil to the O-ring of the new oil filter
9. Once the O-ring of the oil filter is touching the flange, use the respective tool in the following table to tighten to the specified torque.
10. Install the drain plug and refill engine oil. (Refer to P.12-3, Engine Oil Replacement.)

Specified Engine Oil (API classification):

- <6G7> SG or higher
- <4D5> CD or higher

Total quantity (Includes volume inside oil filter and oil cooler):

- <6G7> 4.5 ℓ
- <4D5> 6.5 ℓ

11. Race the engine a few times, and check to be sure that no engine oil leaks from the installation section of the oil filter.

Number	Engine	Tool	Tightening torque
MD352626	6G7	MB991610 or equivalent tool	Approx. 3/4 turn (14 Nm)
MD069782	4D5	MH061590 or equivalent tool	Approx. 5/8 turn (20 Nm)
MD326489			Approx. 3/4 turn (22 Nm)

<Correct>

Commercially-available tool

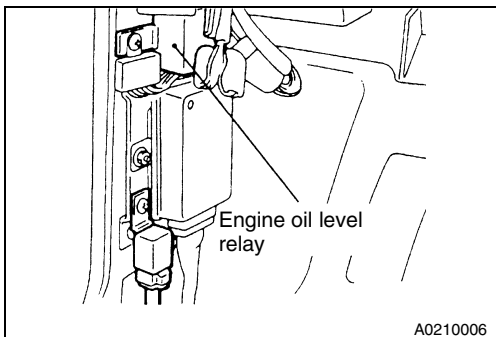

OIL LEVEL WARNING SYSTEM CHECK

12100200054

1. Check that the proper amount of oil has been filled.
2. When the ignition switch is turned to ON (do not start the engine), check that the oil level warning lamp illuminates.

NOTE

If the oil level warning lamp does not illuminate, the cause is probably a blown lamp, or a malfunction in the relay.

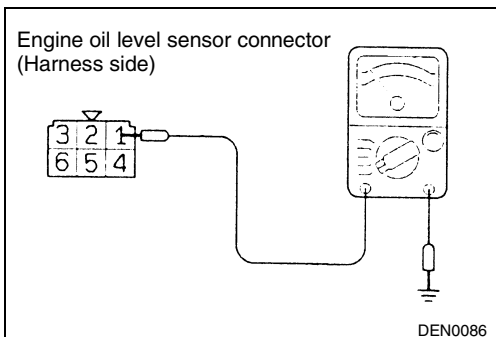

3. When the engine is started, check that the oil level warning lamp turns off.

If the oil level warning lamp will not go out, disconnect the connector of the oil level relay and measure the voltage of the No.1 terminal on the harness side of the connector while idling the engine in order to confirm that it is the same as the battery voltage.

NOTE

- (1) If the voltage at the connector is the same as the battery voltage, the problem is probably a malfunction of either the oil level relay or the oil level sensor.

LUBRICANTS

12100040076

Items		4G63	4G64	4D56	4D56-Turbo
Engine oil API classification		SG or higher	SG or higher	CD or higher	CD or higher
Engine oil quantity ℓ	Oil filter	0.3	0.3	0.8	0.8
	Oil cooler	-	-	0.4	0.4
	Total	4.3	4.3	6.2	6.5

SPECIAL TOOLS

12100050065

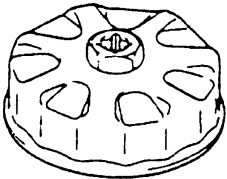
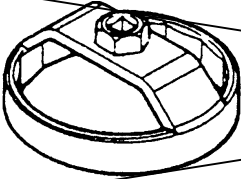
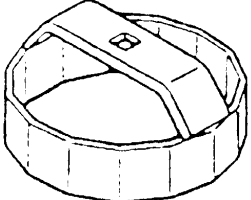
Tool	Number	Name	Use
	MB991396	Oil filter wrench	Removal and installation of engine oil filter (when using the oil filter of MD135737) <4G6>
	MB991610	Oil filter wrench	Removal and installation of engine oil filter (When using the oil filter of MD136466) <4G6>
	MH061590 <Deleted>	Oil filter wrench	Removal and installation of engine oil filter (When using the oil filter of MD069782 or MD326489) <4D56>

ON-VEHICLE SERVICE

12100090057

ENGINE OIL CHECK

1. Check the engine oil using the oil level gauge.
2. Check that the oil is not excessively dirty, that there is no coolant or petrol mixed in, and that it has sufficient viscosity.

ENGINE OIL REPLACEMENT

12100100071

1. Start the engine and allow it to warm up until the temperature of the coolant reaches 80°C to 90°C.
2. Remove the engine oil filler cap.
3. Remove the drain plug to drain oil.

Caution
Use care as oil could be hot.

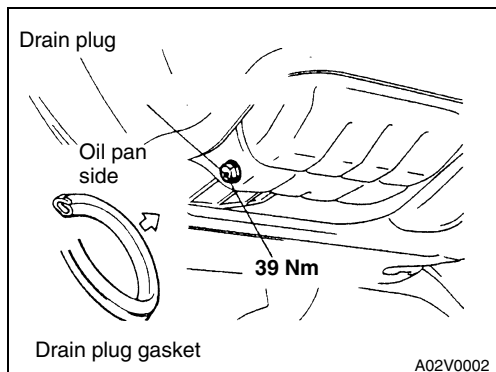

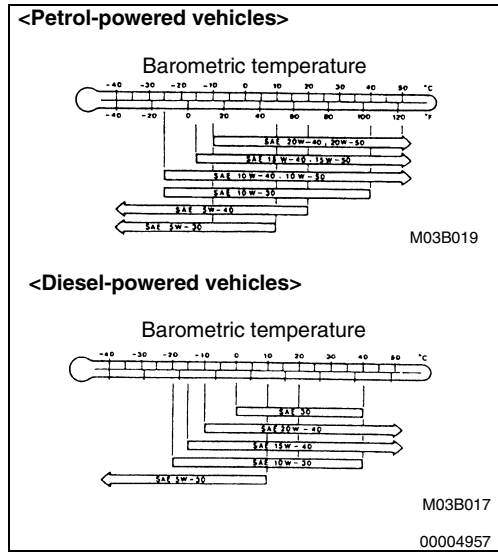

4. Install a new drain plug gasket so that it faces in the direction shown in the illustration, and then tighten the drain plug to the specified torque.
5. Refill with specified quantity of oil.

Specified Engine Oil (API classification):

- <4G63, 4G64> SG or higher
- <4D56> CD or higher

Total quantity (includes volume inside oil filter and oil cooler):

- <4G63> 4.3 l
- <4G64> 4.3 l
- <4D56> 6.2 l
- <4D56-Turbo> 6.5 l

6. Install the engine oil filler cap.
7. Check oil level.

OIL FILTER REPLACEMENT

12100110067

1. Start the engine and allow it to warm up until the temperature of the coolant reaches 80°C to 90°C.
2. Remove the engine oil filler cap.
3. Remove the under cover.
4. Remove the drain plug to drain oil.

Caution

Use care as oil could be hot.

5. Remove the air cleaner, and cover the alternator with a rag so that oil will not get on the alternator. <4D56>
6. Use the following tools to remove the engine oil filter.
 - MB991396 or equivalent (when using the oil filter of MD135737) <4G6>
 - MB991610 or equivalent (when using the oil filter of MD136466) <4G6>
 - MH061590 or equivalent (when using the oil filter of MD069782 or MD326489) <4D56>
 - Commercial tool (other vehicles than above)
7. Clean the filter bracket side mounting surface.

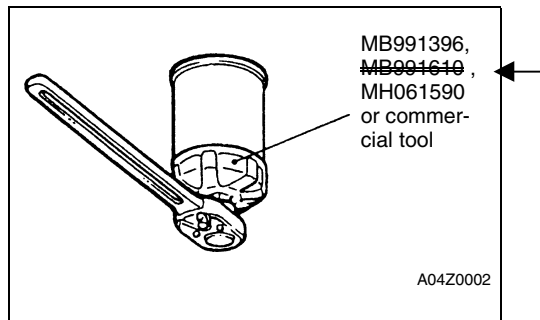

<Deleted>



SERVICE BULLETIN

QUALITY INFORMATION ANALYSIS
OVERSEAS SERVICE DEPT. MITSUBISHI MOTORS CORPORATION

SERVICE BULLETIN		No.: MSB-00E00-003	
		Date: 2000-05-30	<Model> <M/Y>
Subject: YEAR MODEL CHANGES FOR 2001 L200		(EC)L200(K60, K70)	00-10
Group: GENERAL		Draft No.: 00SY0022915	
INFORMATION/ CORRECTION	INTERNATIONAL CAR ADMINISTRATIO OFFICE	 T.NITTA - PROJECT LEADER AFTER SALES SERVICE & CS PROMOTION	
1. Description:			
This Service Bulletin informs you of the year model changes for the 2001 L200			
2. Applicable Manuals:			
	Manual	Pub. No.	Language
	2000 L200 Workshop Manual Chassis	PWTE96E1-D	(English)
		PWTS96E1-D	(Spanish)
		PWTF96E1-D	(French)
		PWTG96E1-D	(German)
3. Details:			

L200

WORKSHOP MANUAL SUPPLEMENT

FOREWORD

This Manual outlines changes in servicing procedures related to the chassis including vehicle inspections, adjustments and improvements in the newly equipped models.

TECHNICAL INFORMATION MANUAL

PYTE96E1

WORKSHOP MANUAL ENGINE GROUP

PWEE_____

(looseleaf edition)

CHASSIS GROUP

PWTE96E1

PWTE96E1-B

(SUPPLEMENT)

PWTE96E1-C

(SUPPLEMENT)

PWTE96E1-D

(SUPPLEMENT)

ELECTRICAL WIRING

PHTE96E1

PHTE96E1-A

PHTE96E1-B

PHTE96E1-D

PHTE96E1-D

(SUPPLEMENT)

BODY REPAIR MANUAL

PBTE96E1

PARTS CATALOGUE

T603B00□D□

General	00
Engine Lubrication	12
Body	42
Interior and Supplemental Restraint System (SRS)	52
Chassis Electrical	54

All information, illustrations and product descriptions contained in this manual are current as at the time of publication. We, however, reserve the right to make changes at any time without prior notice or obligation.

 **MITSUBISHI MOTORS CORPORATION**

© Mitsubishi Motors Corporation

2000

**GROUP 00
GENERAL**

**VEHICLE IDENTIFICATION
MODELS**

Model Code		Engine model	Transmission model	Fuel supply system
K62T	JERDEL6	4G63-SOHC (1,997ml)	R4AW2 (2WD-4A/T	MPI
	ENDEL6		R5M21 (2WD-5M/T)	
K64T	ENDL6	4D56 (2,477ml)	R5M21 (2WD-M/T)	Fuel injection
	ENDR6			
	CENDL6			
	JENDL6			
K75T	CENDEL6	4G64-SOHC (2,351 ml)	V5M21 (4WD-5M/T)	MPI
	GJENXEL6			
K74T	ENDFL6	4D56- Turbocharger with intercooler (2,477ml)	V5MT1 (4WD-5M/T	Fuel injection
	ENDFR6			
	JERDFL6		V4AW2 (AWD-4A/T	
	GJERXFL6		V5MT1 (4WD-5M/T	
	GJENXFL6			
	GJENXFR6			
	CENDFL6			
	GCENXFL6			
	JENDFL6			
	JENDFR6			
	JENHFL6			

CHASSIS NUMBER

M	M	B	J	N	K	7	4	O	1	A	0	0	0	0	0	1
1	2	3	4	5	6	7	8	9	10	11	12					

Y0015AA

No.	Items		Contents
1	Continent	M	ASIA
2	Country	M	THAILAND
3	Register code	B	Follow register
4	Body shape	C	Club cab
		J	Double cab
		O	Single cab
		Y	Single cab without rear body
		Z	Double cab without rear body
5	Transmission type	N	5-speed manual transmission
		R	4-speed automatic transmission
6	Vehicle line	K	Mitsubishi L200
7	Body type	6	Long wheelbase
		7	4WD, Long wheelbase
8	Engine type	2	4G63: 1,997ml petrol engine
		4	4D56:2,477ml diesel engine
		5	4G64: 2,351 ml petrol engine
9	Internal production control code	A	A, B, C...etc 0 (zero): No meaning
10	Model year	1*	2001
11	Plant	A	A, C: LARDKRABANG factory D, F: LAEMCHABANG factory
12	Serial number	-	-

NOTE

*: Indicates changes.

NOTES

GROUP 12

ENGINE LUBRICATION

GENERAL

OUTLINE OF CHANGES

- A quality of the engine oil has been changed.

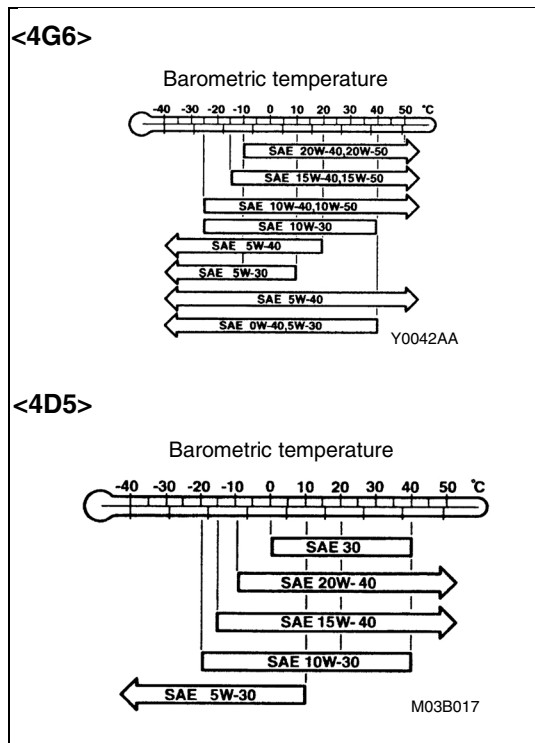

ON-VEHICLE SERVICE

specified engine oil (ACEA and API classification):

<4G6> ACEA A1, A2, A3/API SG or higher

<4D5> ACEA B1, B2, B3, B4/API CD or higher

NOTES

**GROUP 42
BODY**

GENERAL

OUTLINE OF CHANGES

The following service procedures have been added due to the introduction of the keyless entry system as an optional equipment <GLS>.

KEYLESS ENTRY SYSTEM

SPECIAL TOOL

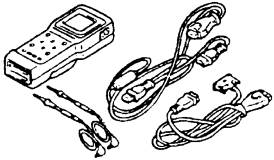
Tool	Number	Name	Use
	MB991502	MUT-II sub assembly	Encrypted codes recording

TROUBLESHOOTING

DIAGNOSIS FUNCTION

INPUT SIGNAL INSPECTION PROCEDURE

1. Connect the MUT-II to the diagnosis connector to check input signal. (Refer to '97 L200 Workshop Manual GROUP 00 – How to Use Troubleshooting/Inspection Service Points.)
2. The following input signals can be checked:
 - Ignition switch (IG1, ACC)
 - Driver's door switch
 - Every door switch
 - Key reminder switch
 - Driver's door lock actuator
 - Keyless entry transmitter (LOCK, UNLOCK)

NOTE

If the MUT-II cannot check all the input signals, the diagnosis circuit may be defective.

ETACS FUNCTION ADJUSTMENT PROCEDURE

The following functions can be adjusted by operating input switches, The adjustments will be stored in th ECU memory even after a battery cable is disconnected:

- Switching of keyless entry answerback function (From activation to deactivation, or vice versa)
- Initialisation of the above function (From deactivation)

1. Entry conditions to the adjustment mode

The ETACS-ECU sounds a buzzer once when all of the following conditions are satisfied, and then enters the adjustment mode:

- Diagnosis control: ON (Connect the MUT-II.)
- Key reminder switch: OFF
- Ignition switch: LOCK (OFF)
- Door switch: OFF (Close the door)
- If all of the conditions above are satisfied, the tailgate switch will be turned in for more than 10 seconds.

2. Exit conditions from the adjustment mode

The ETACS-ECU cancels the adjustment mode when any of the following conditions is satisfied:

- Diagnosis control: OFF (Disconnect the MUT-II>)
- Key reminder switch: ON (Pull out the ignition key.)
- Ignition switch: Other than LOCK (OFF)
- Door switch: ON (Open the door)
- After the ETACS_ECU has entered the adjustment mode, no adjustment is made within 3 minutes (If any adjustment is made within 3 minutes, the ETACS-ECU monitors an adjustment operation for other 3 minutes.
- Other warning buzzer(s) sounds

3. Adjustment of functions

Function	Adjustment procedure
Keyless entry answerback function	<p>When the transmitter lock switch is turned on twice continuously within 2 seconds, the lock answerback function toggles on and off.</p> <ul style="list-style-type: none"> • If the function toggles on, the buzzer sounds once (default condition). • If the function toggles off, the buzzer sounds twice, <p>When the transmitter unlock switch is turned on twice continuously within 2 seconds, the unlock answerback function toggles on and off.</p> <ul style="list-style-type: none"> • If the function toggles on, the buzzer sounds once (default condition). • If the function toggles off, the buzzer sounds twice,
Initialisation of all the ETACS functions (From deactivation to activation)	<p>When the tailgate switch remains on for more than 20 seconds, the buzzer sounds twice and the answer-back function of the keyless entry system is initialised.</p> <p>The buzzer will sound in 10 seconds (indicating that the ETACS-ECU enters the adjustment mode), but the washer switch must remain off for 20 seconds in order to initialise all the functions.</p> <p>If the tailgate switch remains on for more than 20 seconds without entering the adjustment mode, the system enters the adjustment mode in 10 seconds, but does not initialise all of the functions.</p>

INSPECTION CHART FOR TROUBLE SYMPTOMS

Trouble symptom	Inspection procedure No.	Reference page
None of the doors can be locked or unlocked using the transmitter.	1	42-3
All of the doors can be locked and unlocked using the transmitter, but the room lamp or turn-signal lamp does not flash or illuminate. (However, the room lamp operates normally when the doors are opened and closed.)	2	42-4
Encrypted codes cannot be registered.	3	42-5

INSPECTION PROCEDURE FOR TROUBLE SYMPTOMS

INSPECTION PROCEDURE 1

None of the doors can be locked or unlocked using the transmitter.	Probable cause
The cause may be a malfunction of the transmitter or ETACS-ECU, defective connection between ETACS-ECU and junction block, defective power supply voltage to ETACS-ECU input line due to commercial equipment, or the lock and unlock signals are not being sent to the ETACS-ECU.	<ul style="list-style-type: none"> • Malfunction of transmitter • Malfunction of ETACS-ECU • Malfunction of key reminder switch • Malfunction of wiring harness or connector • Malfunction of door switch • Defective connection between ETACS-ECU and junction block • Defective power supply voltage to ETACS-ECU input line due to commercial equipment

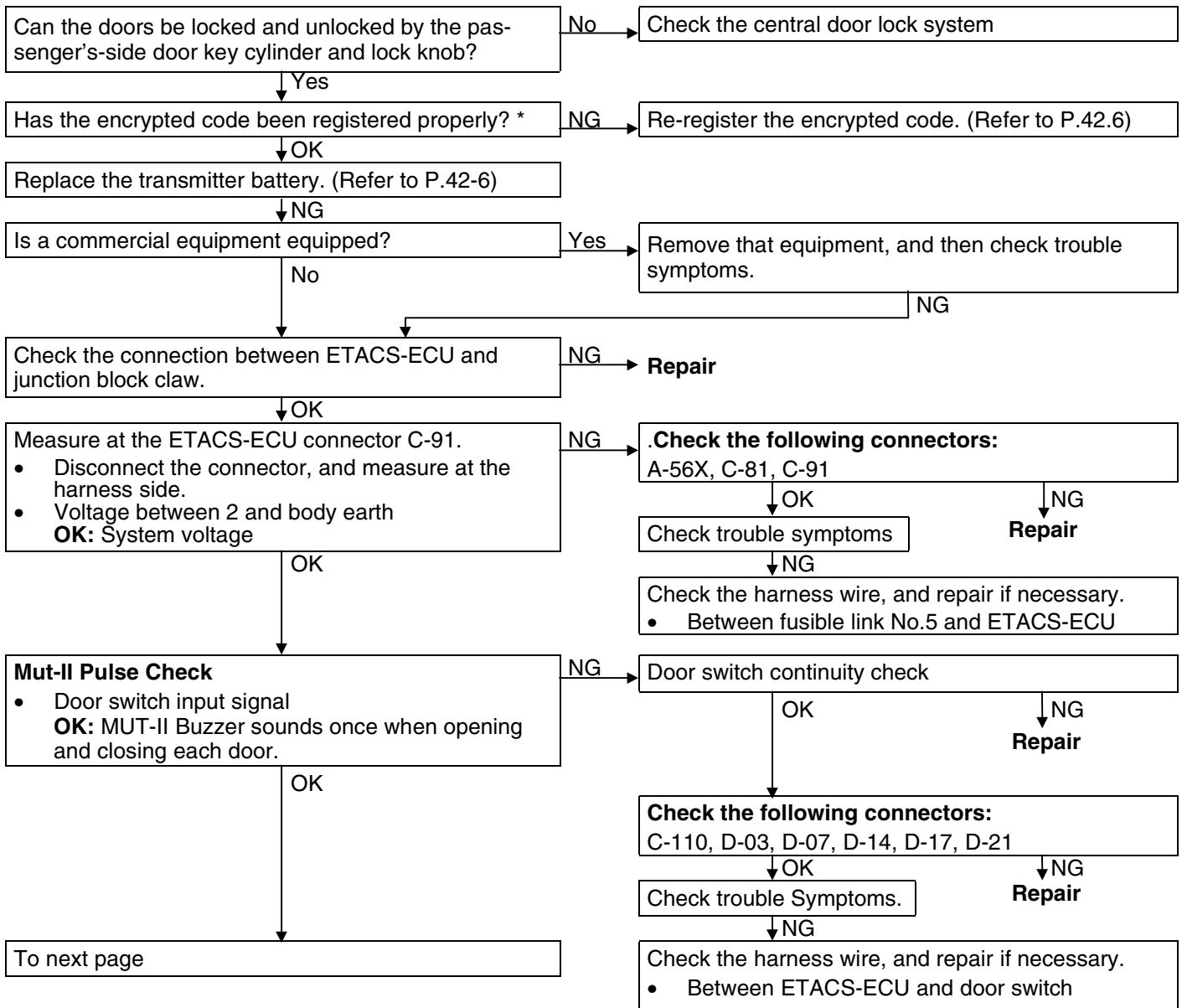

NOTE

*: This should be done if a transmitter, receiver or ETACS-ECU has been replaced, and if a secret cod has not been registered properly

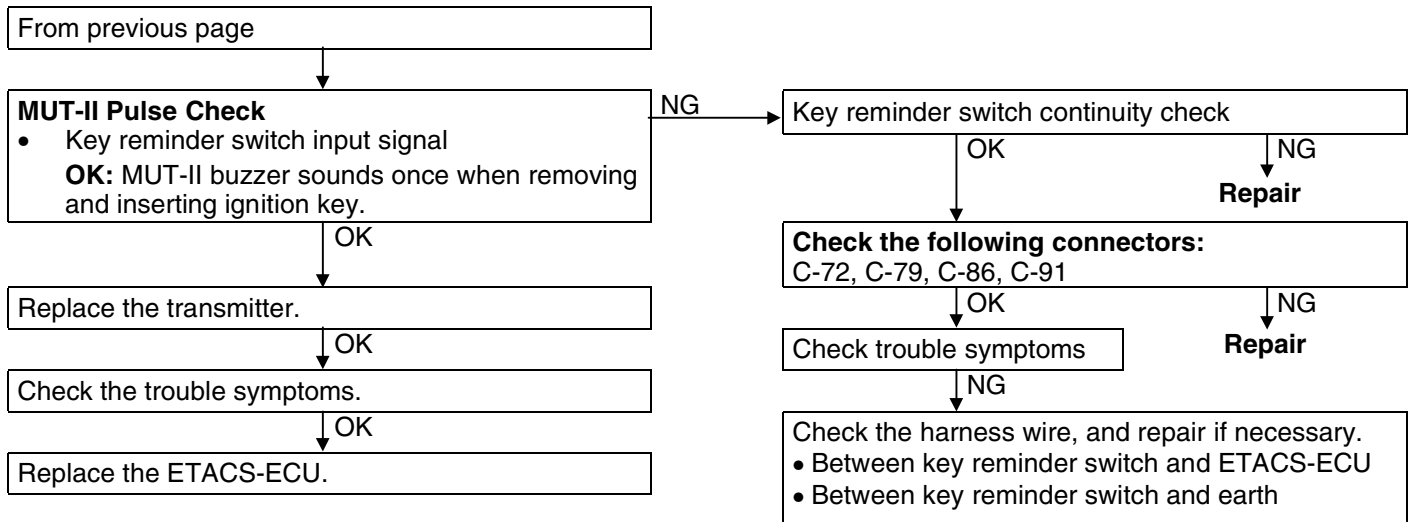

INSPECTION PROCEDURE 2

All of the doors can be locked and unlocked using th transmitter, but the room lamp or turn-signal lamp does not flash or illuminate. (However, the room lamp operates normally when the doors are opened and closed.)	Probable cause
<p>If neither room lamp nor turn-signal lamp flash/illuminate, the cause may be a malfunction of the ETACS-ECU or driver’s-side door lock actuator.</p> <p>If either room lamp or turn-signal lamp does not flash/illuminate, the cause may be a malfunction of the room lamp circuit or turn-signal lamp.</p>	<ul style="list-style-type: none"> • Malfunction of ETACS-ECU • Malfunction of driver’s door lock actuator • Burnt turn-signal lamp bulb • Malfunction of connector or wiring harness

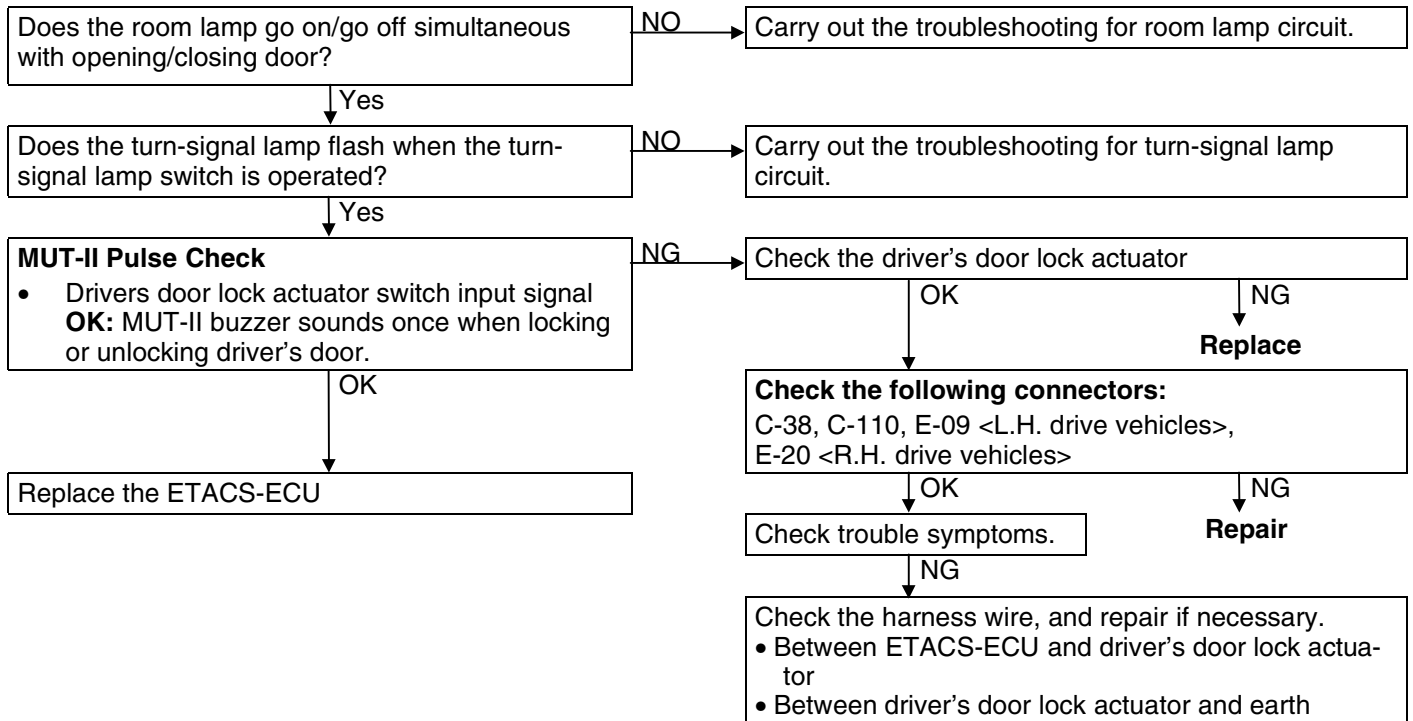

INSPECTION PROCEDURE 3

Encrypted codes cannot be registered	Probable cause
The cause may be a malfunction of the diagnosis connector, ETACS-ECU or diagnosis output circuit.	<ul style="list-style-type: none"> • Malfunction of MUT-II • Malfunction of connector or wiring harness • Malfunction of ETACS-ECU

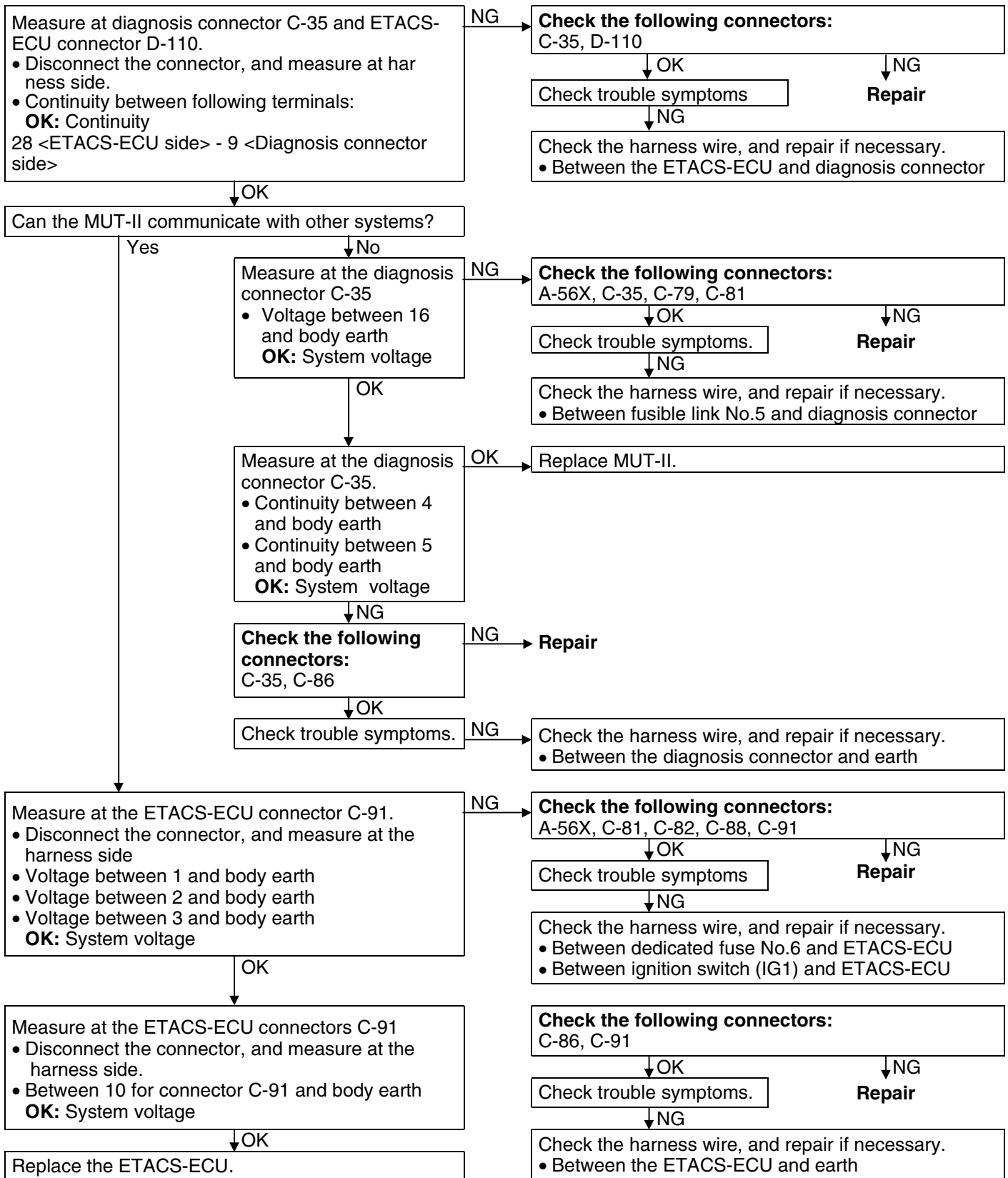

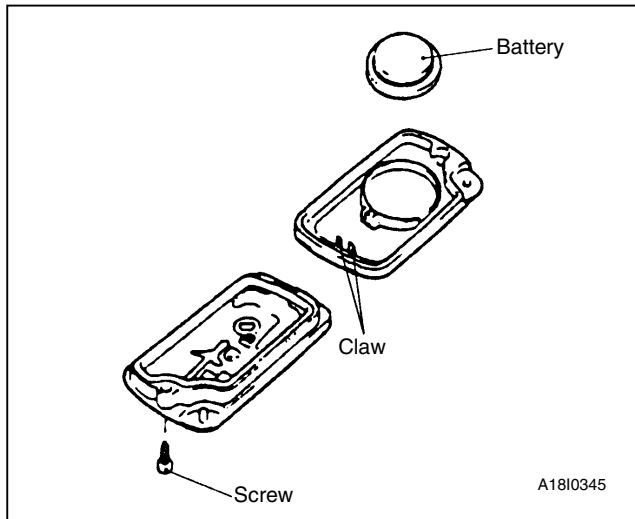

ON – VEHICLE SERVICE HOW TO REPLACE A BATTERY OF THE TRANSMITTER

1. Remove the set screw to remove the battery from the transmitter.

Install a battery with its (+) side face-down.

Battery required for replacement:

Coin type battery CR2032

3. Insert the claw, and then assemble the transmitter.

Caution

Do not let water or dust stick to the inside of the transmitter when it is open. Also, do not touch the precision electronic device.

4. Check to see if the keyless entry system operates.

SECRET CODE REGISTRATION METHOD

Each individual secret code is registered inside the transmitter, and so it is necessary to register these codes with the EEPROM inside the ETACS-ECU in the following cases.

- When either the transmitter or ETACS-ECU in the following cases.
- If a second transmitter is to be used;
- If it appears that a problem is occurring because of faulty registration of a code.

A maximum of two different codes can be stored in the memory area of the EEPROM (two different transmitters can be used).

When the code for the first transmitter is registered, the previously- registered codes for two transmitters are cleared.

Therefore, if you are using more than two or are adding a second transmitter, the codes for all the transmitters must be registered at the same time.

1. Check that the doors lock normally when the key is used.

2. Connect the MUT-II to the diagnosis connector

NOTE

This will connect terminal (1) of the diagnosis connector to earth, and the system will be in secret code registration standby mode.

Caution

Always turn the ignition switch to OFF before connecting and disconnecting the MUT-II

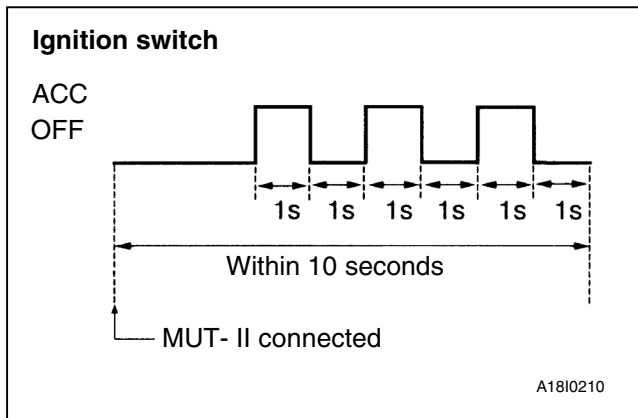

3. Within 10 seconds after connecting the MUT-II, turn the ignition switch to ACC ON for 1 second and then to OFF for 1 second; repeat this procedure three times.

NOTE

The doors will lock and unlock once at this time and the system will switch to registration mode.

4. Press the lock switch or unlock switch; of the transmitter switch, and then press it two times within 10 seconds of the first press. This will register the code.
5. After registration is completed, the doors will be automatically locked and unlocked once.
6. If you are using two transmitters or have added a second transmitter, the same registration procedure should be carried out for the second transmitter, and it should be carried out within one minute after registration of the code for the first transmitter has been completed. After the second registration is completed, the doors will be automatically locked and unlocked once.
7. Registration mode will be terminated under the following conditions.
 - When the secret codes for two transmitters have been registered;
 - When one minute has passed after registration mode started;
 - If the MUT-II is disconnected (earth is released);
 - If the ignition switch is turned to ON;
8. After registration mode has been completed, carry out the followings to make sure that the keyless entry system operates.
 - Pull the ignition key out.
 - Close the all doors.

KEYLESS ENTRY SYSTEM REMOVAL AND INSTALLATION

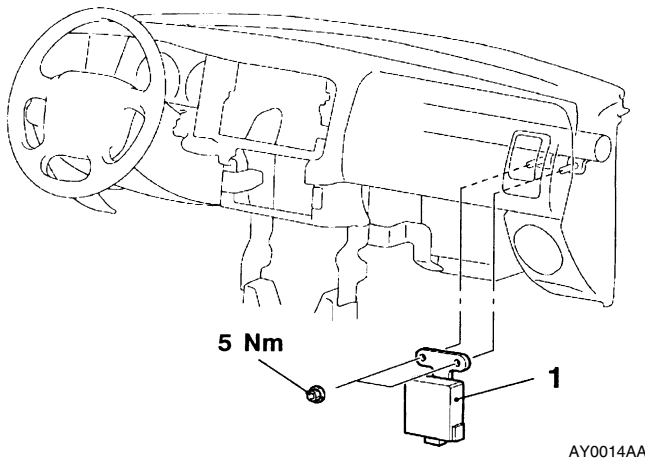

Keyless entry receiver-ECU removal steps

- Glove box assembly (Refer to GROUP 52A*.)
1. Keyless entry receiver-ECU

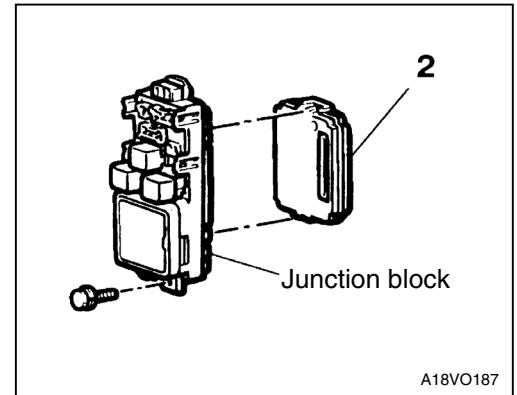

ETACS-ECU removal

2. ETACS-ECU

NOTE

*: Refer to '97 L200 Workshop Manual <Pub. No. PWTE96E1>

**GROUP 52A
INTERIOR**

GENERAL

OUTLINE OF CHANGE

- The following service procedures have been added due to the introduction of the adjustable seat belt anchor.
- On dual cab models, three-point ELR/child seat fixing mechanism (ALR) seat belts have been added for rear seat as an optional equipment. The service procedures are the same as previous one.

FRONT SEAT BELT

REMOVAL AND INSTALLATION

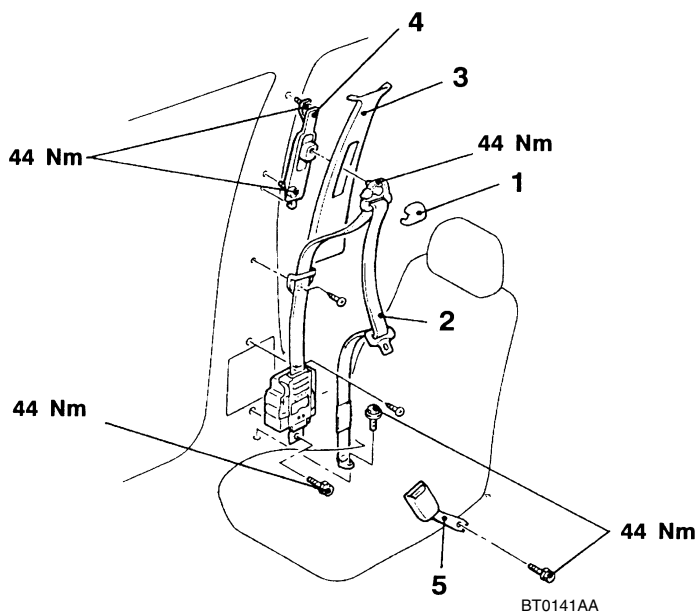

Outer seat belt removal steps

- Center pillar trim, lower or quarter trim, lower (refer to P.52A*.)
1. Sash guide cover
 2. Outer seat belt
 3. Center pillar trim, upper or quarter trim, upper (refer to P.52A*.)
 4. Adjustable seat belt anchor.

Inner seat belt removal steps

- Front seat (refer to P.52A*.)
5. Inner seat belt

NOTE

*: Refer to '97 L200 Workshop Manual <Pub. No. PWTE96E1>.

NOTES

GROUP 54 CHASSIS ELECTRICAL

GENERAL

OUTLINE IF CHANGES

- The following procedure has been added due to the addition of the high-stop lamp <4WD>.

HIGH-MOUNTED STOP LAMP REMOVAL AND INSTALLATION

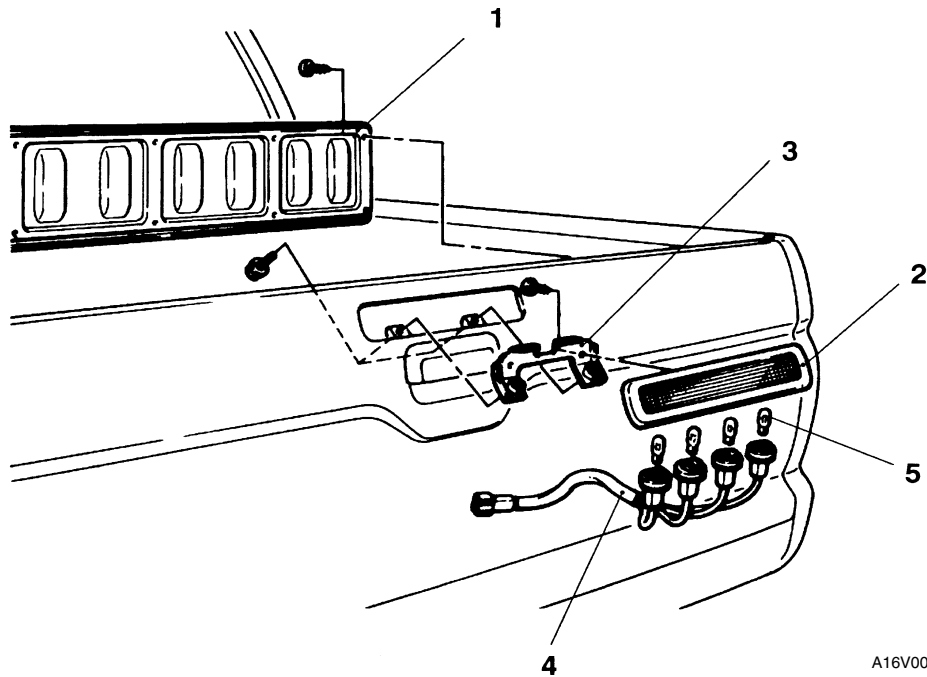

A16V0088

Removal steps

1. Rear gate panel
2. High mounted stop lamp
3. Lamp bracket
4. Bulb socket assembly
5. Bulb

GROUP 12

ENGINE LUBRICATION

GENERAL

OUTLINE OF CHANGE

- Due to the adoption of the VG (Variable Geometry) turbocharger, the engine oil quantity has been changed. <4WD vehicles with 4D56-Step III engine>

LUBRICANT

Items	4WD vehicles with 4D56-Step III engine	
Engine oil quantity L	Oil filter	0.8
	Oil cooler	0.4
	Total	7.5

NOTES