FRONT SUSPENSION

FRONT SUSPENSION

CONTENTS

3320900080

GENERAL INFORMATION	2	SHOCK ABSORBER AND UPPER ARM	
SERVICE SPECIFICATIONS	3	<4WD>	13
SEALANT	3	LOWER ARM, COIL SPRING AND STRUT	
SPECIAL TOOLS	4	BAR <2WD>	16
ON-VEHICLE SERVICE	6	LOWER ARM AND TORSION BAR	
Front Wheel Alignment Check and		<4WD>	19
Adjustment	6	STABILIZER BAR <4WD>	23
SHOCK ABSORBER AND UPPER ARM			
<2WD>	10		

GENERAL INFORMATION

33200010105

The front suspension on 2WD vehicles is an independent suspension system having the double wishbone combined with the coil spring, while the

front suspension on 4WD vehicles is an independent suspension having the double wishbone combined with the torsion bar spring.

COIL SPRING <2WD>

Items	4G63-Single cab, 4D56-Club cab	4G63-Double cab, 4D56-Single cab	4D56-Double cab
Wire dia. x O.D. x free length mm	16 × 99 × 280 [17 × 100 × 275]	16 × 100 × 284 [17 × 100 × 279]	16 × 100 × 288 [17 × 100 × 283]

NOTE

[]: indicates option

TORSION BAR <4WD>

Items	Specification
Length x O.D. mm	1,367 × 26 [1,367 × 27]

NOTE

[]: Indicates option

CONSTRUCTION DIAGRAM

<2WD>

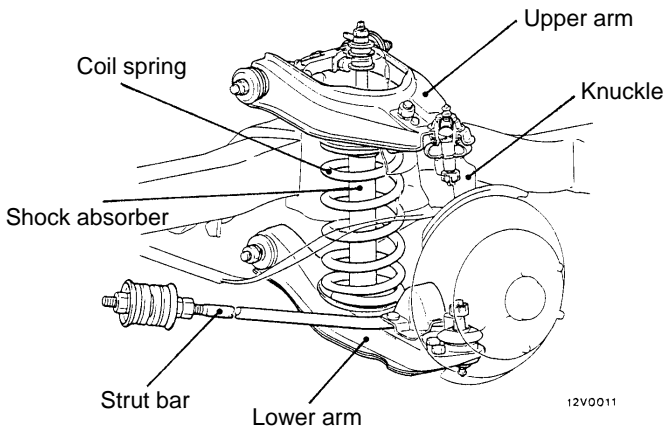

<4WD>

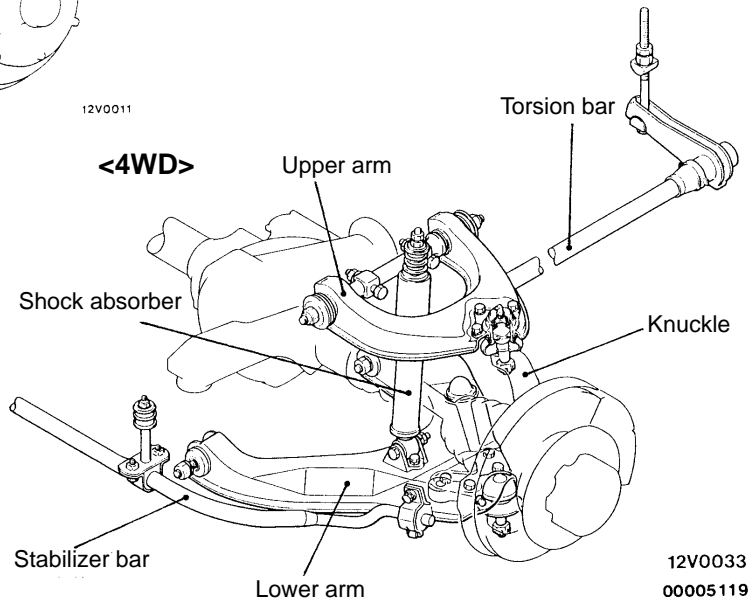

SERVICE SPECIFICATIONS

33200030088

Items		Standard value	Limit	
Toe-in	At the centre of tyre thread mm	0 – 7	–	
	Toe-angle (per wheel)	2WD	0° – 0°19'	–
		4WD <Vehicles with 205/80 R16 tyre>	0° – 0°16'	–
		4WD <Vehicles with 31 x 10.50 R15 tyre>	0° – 0°15'	–
Camber		0°10' – 1°10' (Difference between right and left within 30')	–	
Caster	2WD	1°45' – 3°45' (Difference between right and left within 30')	–	
	4WD	1°15' – 3°15' (Difference between right and left within 30')	–	
Kingpin inclination	2WD	15°00'	–	
	4WD	14°50'	–	
Shock absorber attaching dimension mm		1 – 2	–	
Upper arm ball joint starting torque Nm	2WD	0.8 – 3.4	–	
Strut bar attaching dimension mm		79	–	
Lower arm ball joint end play mm		–	0.5	
Lower arm bush press-fitting force kN		9.8	–	
Clearance between bump stopper and bump stopper bracket mm	4WD	21 – 23	–	
Stabilizer link assembly attaching dimension mm	4WD	16 – 18	–	

SEALANT

33200050015

Item	Specified sealant
Upper arm ball joint dust cover <2WD>	3M ATD Part No. 8661 or equivalent

SPECIAL TOOLS

33200060070

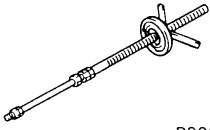
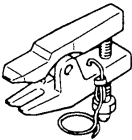
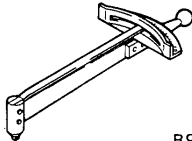
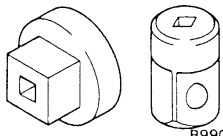
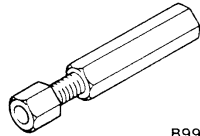
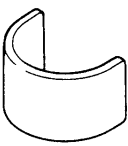
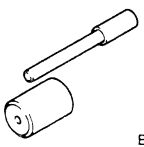
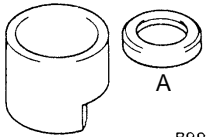
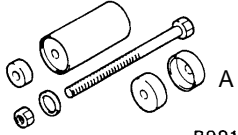
Tool	Number	Name	Use
 B990792	MB990792	Front coil spring compressor	Front suspension coil spring compression <2WD>
 B991113	MB991406	Steering linkage puller	Upper or lower arm ball joint disconnection
 B990968	MB990968	Torque wrench	Upper arm ball joint rotation torque measurement
 B990326	MB990326	Preload socket	
 B990804	MB990804	Knuckle arm puller	Upper arm ball joint disconnection <2WD>
 B991639	MB991639	Bushing remover and installer support	Preventing deformation when removing and installing the lower arm bushing <2WD>
 B990649	MB990649	Lower arm bushing remover and installer	Lower arm bushing removal and press-fitting <2WD>
 B991071	MB991071 A: MB991072	Lower arm bushing remover and installer A: Arbor	Lower arm bushing removal <2WD>
 B991522	MB990958 A: MB990975	Torsion bar bushing remover and installer A: Installer guide	Lower arm bushing press-fitting <2WD>

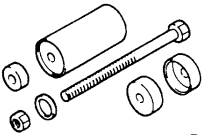
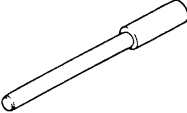
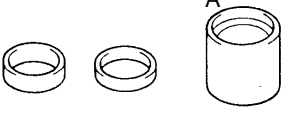
Tool	Number	Name	Use
 <p>B991522</p>	MB991522	Torsion bar bushing remover and installer	Lower arm bushing (A) removal and press-fitting <4WD>
 <p>B990883</p>	MB990883	Rear suspension bushing arbor	Lower arm bushing (B) removal and press-fitting <4WD>
 <p>A B990957</p>	MB990957 A: MB990971	Lower arm bushing remover and installer A: Base	

ON-VEHICLE SERVICE

33100090113

FRONT WHEEL ALIGNMENT CHECK AND ADJUSTMENT

Measure the wheel alignment with the vehicle parked on a level surface.

The front suspension, steering system, and wheels should be serviced to normal condition prior to measurement of wheel alignment.

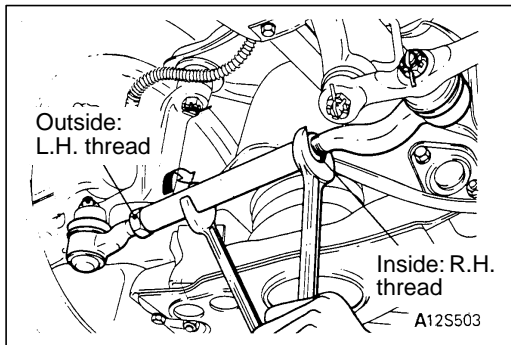

TOE-IN

Standard value:

At the centre of tyre tread 0 – 7 mm

Toe angle (per wheel)

0° – 0°19' <2WD>

0° – 0°16' <4WD (Vehicles with 205/80 R16 tyre)>

0° – 0°15' <4WD (Vehicles with 31 x 10.50 R15 tyre)>

1. If the toe-in is not within the standard value, adjust the toe-in by turning the left and right tie rod turnbuckles by the same amount (in opposite directions).

NOTE

The toe will move out as the left turnbuckle is turned toward the front of the vehicle and the right turnbuckle is turned toward the rear of the vehicle.

2. Use a turning radius gauge to check that the steering angle is at the standard value. (Refer to GROUP 37A – On-vehicle Service.)

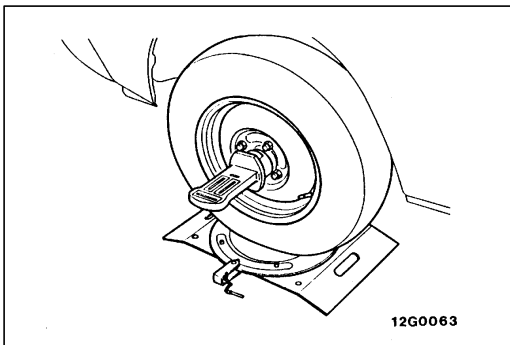

CAMBER AND CASTER

<2WD>

Standard value:

Camber 0°10' – 1°10' (Difference between right and left within 30')

Caster 1°45' – 3°45' (Difference between right and left within 30')

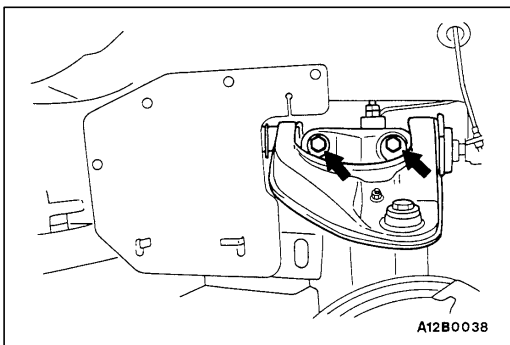

If the standard value is not obtained, make adjustment by the following procedure.

1. Loosen the upper arm mounting bolts and nuts.

NOTE

Remove the shock absorber mounting nut and lock nut, compress the shock absorber and loosen the upper arm mounting bolts and nuts.

2. Increase or decrease shims between upper arm shaft and crossmember to adjust the camber and caster. (Refer to Charts for Shim Increase or Decrease.)

Caution

1. Difference in shim thickness between front and rear must be 4 mm or less.
2. Do not use 4 or more shims at one location.

Adjustment of shim	
Part number	Thickness mm
MR132525	1
MR132526	2
MR210107 (Front shim integral with rear shim)	1
MB932441 (Front shim integral with rear shim)	2

Charts for Shim Increase or Decrease

HOW TO USE CHARTS

These charts show how shims are added to or removed from existing shims.

EXAMPLE

To decrease camber by 36' and increase caster by 24', increase combined front side shim thickness by 1 mm and increase combined rear side shim thickness by 2 mm.

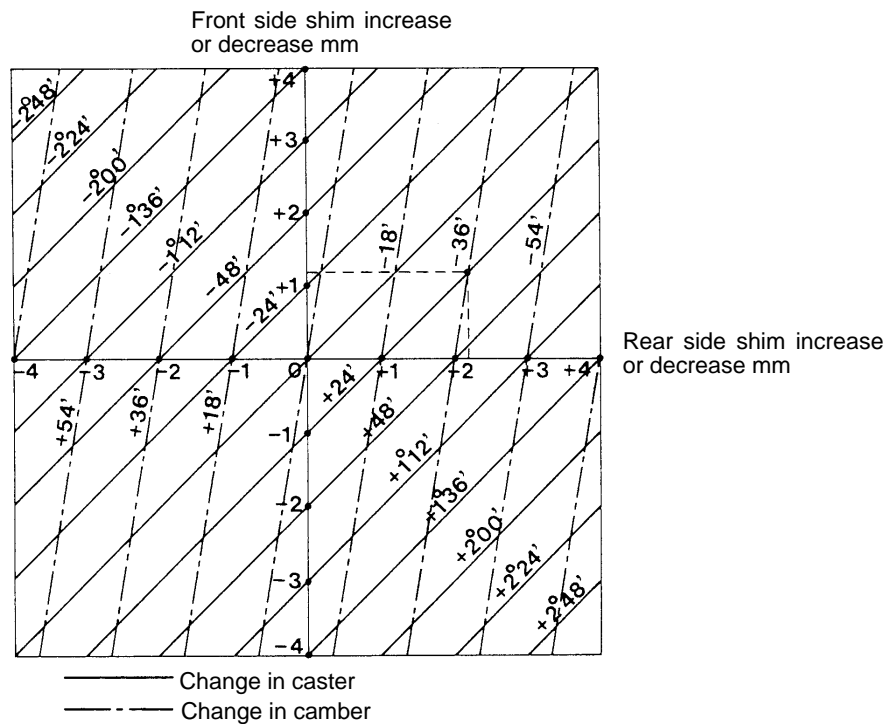

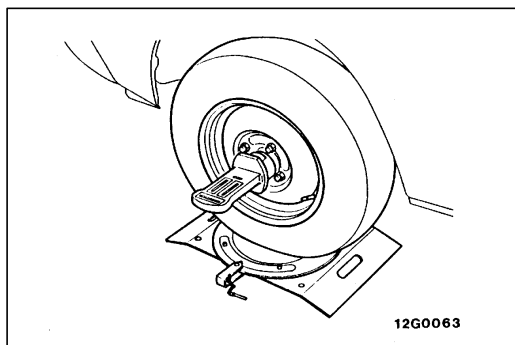

<4WD>

Standard value:

Camber $0^{\circ}10'$ – $1^{\circ}10'$ (Difference between right and left within 30')

Caster $1^{\circ}15'$ – $3^{\circ}15'$ (Difference between right and left within 30')

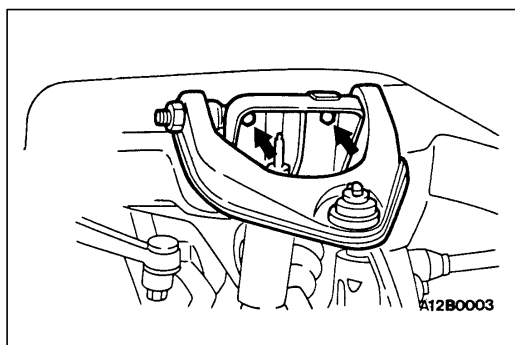

If the standard value is not obtained, make adjustment by the following procedure.

1. Loosen the upper arm mounting bolts and nuts.

NOTE

Remove the shock absorber mounting nut and lock nut, compress the shock absorber and loosen the upper arm mounting bolts and nuts.

2. Increase or decrease shims between upper arm shaft and crossmember to adjust the camber and caster. (Refer to Charts for Shim Increase or Decrease.)

Caution

1. **Difference in shim thickness between front and rear must be 4 mm or less.**
2. **Do not use 4 or more shims at one location.**

Adjustment of shim	
Part number	Thickness mm
MR132525	1
MR132526	2
MB176288 (Front shim integral with rear shim)	1
MB176289 (Front shim integral with rear shim)	2

Charts for Shim Increase or Decrease

HOW TO USE CHARTS

These charts show how shims are added to or removed from existing shims.

EXAMPLE

To decrease camber by 30' and caster by 40', increase combined front side shim thickness by 3 mm and increase combined rear side shim thickness by 2 mm.

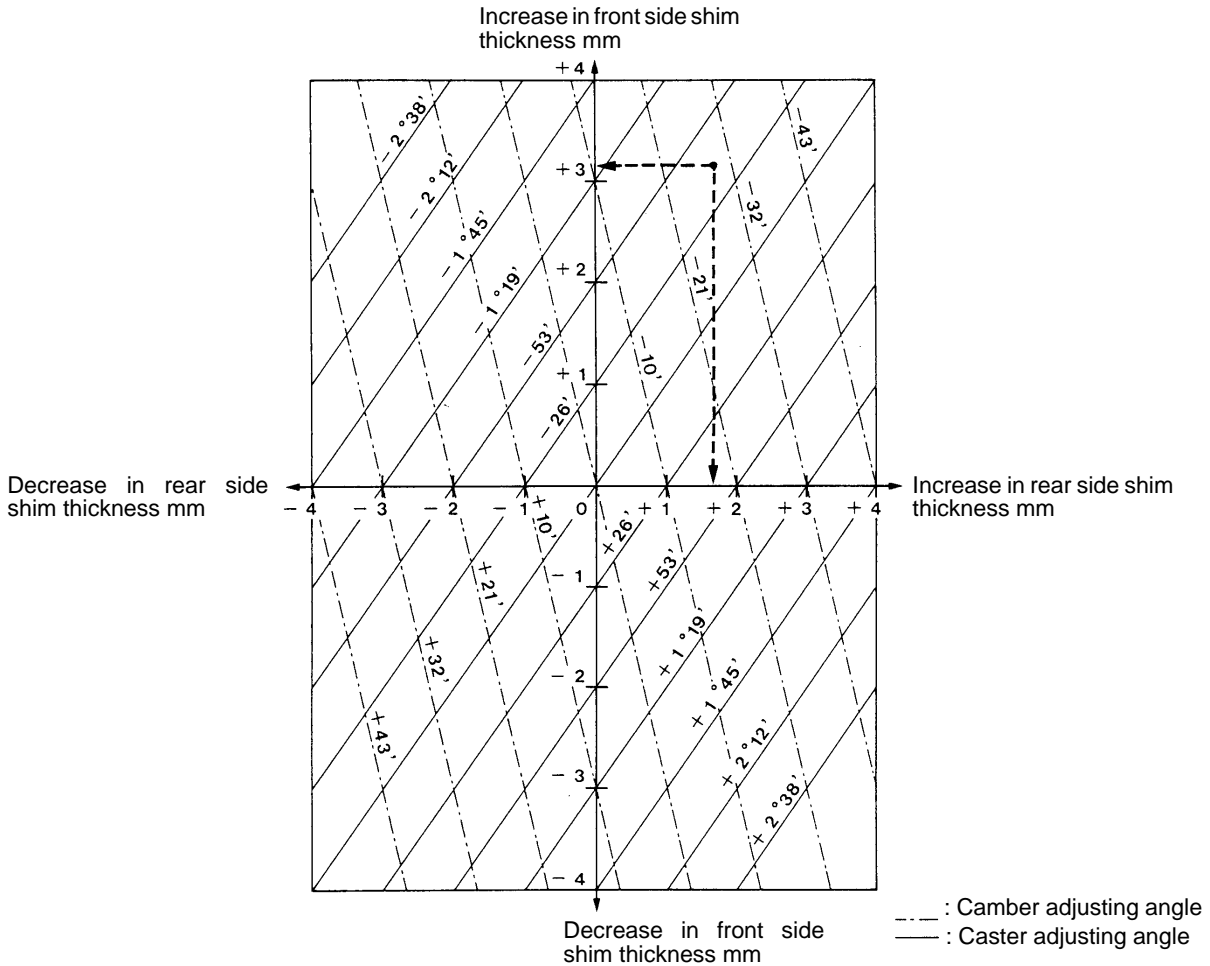

12V0034

KINGPIN INCLINATION

Standard value:
 <2WD> 15°00'
 <4WD> 14°50'

SHOCK ABSORBER AND UPPER ARM <2WD>

33200250026

REMOVAL AND INSTALLATION

Post-installation Operation

- Front Wheel Alignment Check and Adjustment (Refer to P.33A-6.)

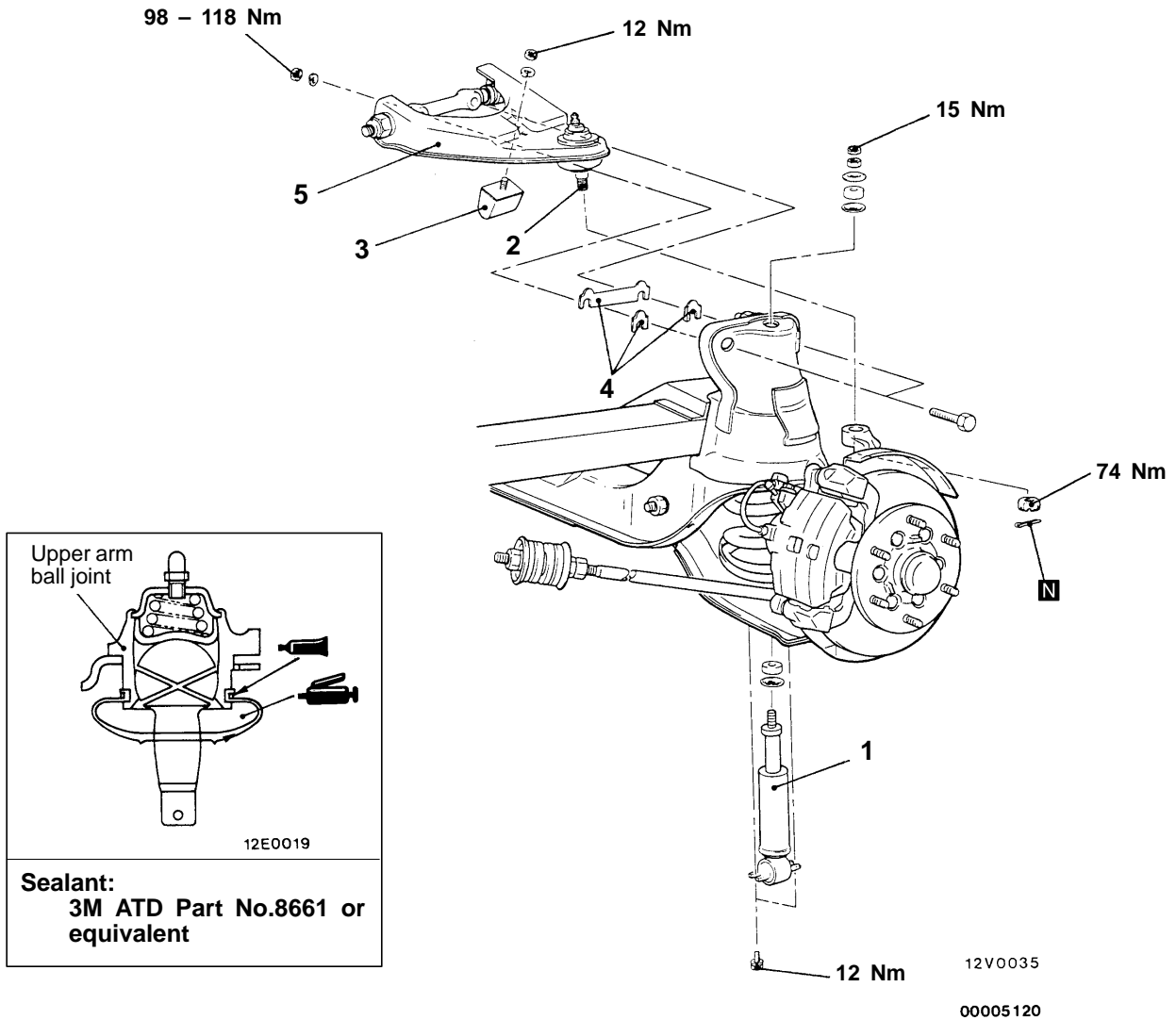

Removal steps

- ◀A▶ ▶B▶
1. Shock absorber
 2. Upper arm ball joint connection
 3. Rebound stopper

- ◀B▶ ▶A▶
4. Shims
 5. Upper arm

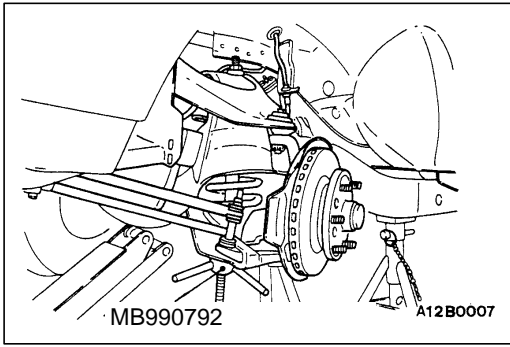

REMOVAL SERVICE POINTS

◀A▶ UPPER ARM BALL JOINT DISCONNECTION

1. Install the special tool to compress the coil spring slightly.

2. Use the special tool to disconnect the upper arm ball joint from the knuckle.

Caution

1. Use the special tool to loosen the nut only do not remove it from the ball joint.
2. Tie the special tool with a cord not let it fall off.

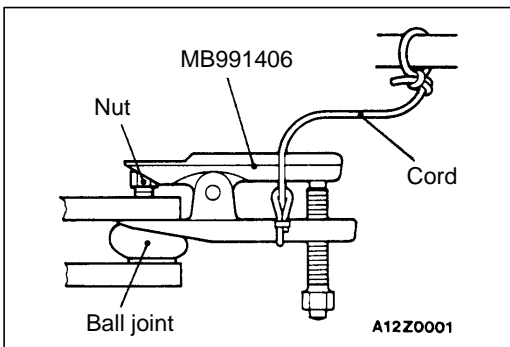

◀B▶ SHIMS REMOVAL

NOTE

The camber adjustment shims should be stored for reference at assembly.

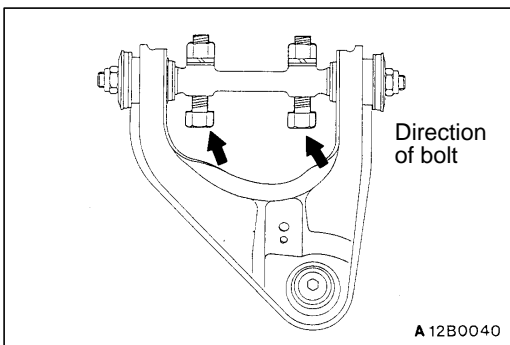

INSTALLATION SERVICE POINTS

▶A◀ UPPER ARM INSTALLATION

When the upper arm assembly is installed to the crossmember, insert the upper arm shaft attaching bolts from outside the crossmember and put adjusting shims between the crossmember and upper arm shaft.

▶B◀ SHOCK ABSORBER INSTALLATION

Install the shock absorber so that the distance (A) shown in the illustration is at the standard value.

Standard value (A): 1 – 2 mm

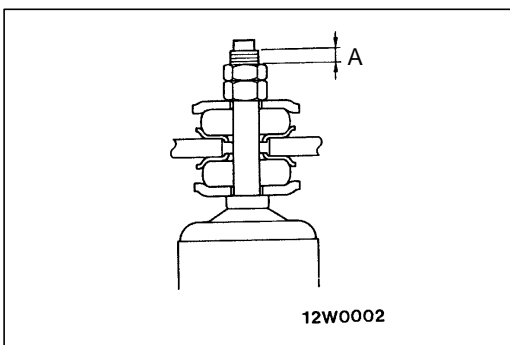

33A-12 FRONT SUSPENSION – Shock Absorber and Upper Arm <2WD>

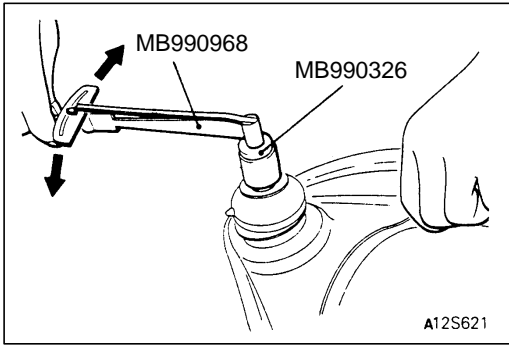

INSPECTION

33200260029

UPPER ARM BALL JOINT STARTING TORQUE CHECK

1. After shaking the upper arm ball joint stud several times, install the nut to the stud and use the special tool to measure the starting torque of the upper arm ball joint.

Standard value: 0.8 – 3.4 Nm

2. If the starting torque exceeds the standard value, replace the upper arm assembly.
3. If the starting torque is lower than the standard value, check that the ball joint turns smoothly without excessive play. If so, it is possible to use that ball joint.

UPPER ARM BALL JOINT DUST COVER CHECK

When dust cover is cracked or damaged, replace the upper arm assembly.

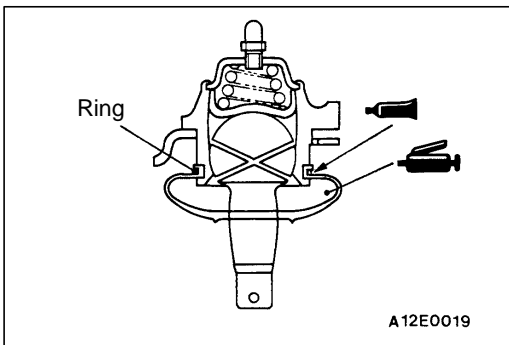

UPPER ARM BALL JOINT DUST COVER REPLACEMENT

33200800023

Only when dust cover is damaged accidentally during service work, replace the dust cover as follows.

1. Apply multipurpose grease to inside of the dust cover.
2. Apply specified sealant to the groove of the ball joint, and then securely install the dust cover and ring.

Specified sealant: 3M ATD Part No.8661 or equivalent

SHOCK ABSORBER AND UPPER ARM <4WD>

33200250033

REMOVAL AND INSTALLATION

Pre-removal Operation

- Brake Fluid Draining

Post-installation Operation

- Brake Fluid Supplying
- Brake Line Bleeding (Refer to GROUP 35A – On-vehicle Service.)
- Front Wheel Alignment Check and Adjustment (Refer to P.33A-6.)

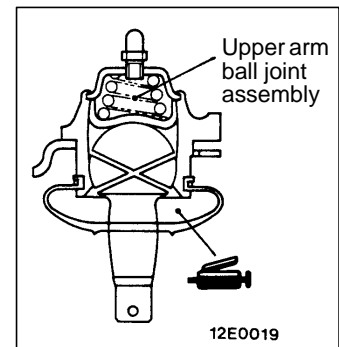
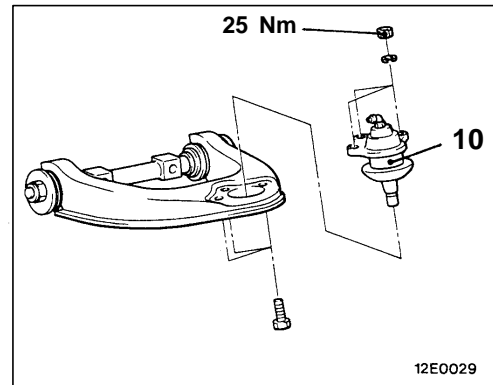
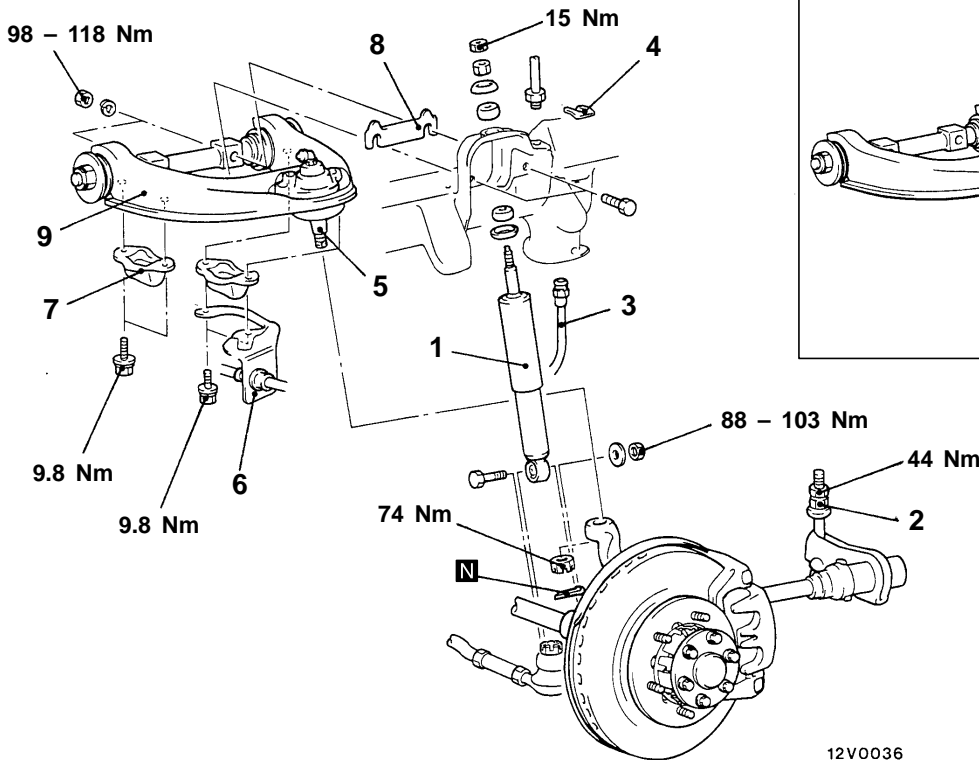

00005121

Removal Steps

- ▶C◀ 1. Shock Absorber
- Adjustment of clearance from bump stopper to bump stopper bracket (Refer to P.33A-20.)
- ◀A▶ 2. Anchor arm assembly adjusting nut
3. Brake hose connection
4. Hose clip

- ◀B▶ 5. Upper arm ball joint connection
- ▶B◀ 6. Brake hose support
- ◀C▶ 7. Rebound stopper
- ▶A◀ 8. Shims
9. Upper arm
10. Upper arm ball joint assembly

33A-14 FRONT SUSPENSION – Shock Absorber and Upper Arm <4WD>

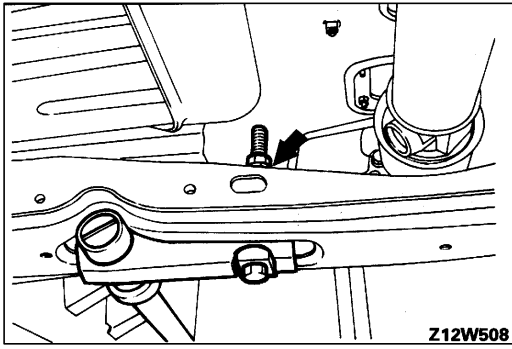

REMOVAL SERVICE POINTS

◀A▶ ANCHOR ARM ASSEMBLY ADJUSTING NUT LOOSENING

Loosen the anchor arm bolt of the torsion bar all the way.

NOTE

When the anchor arm assembly installation nut is loosened, use a jack to support the lower arm of the side to be loosened, thus the work easier.

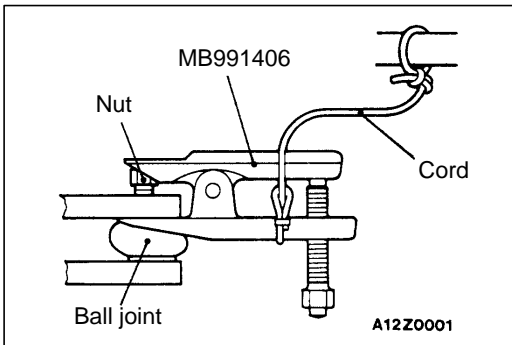

◀B▶ UPPER ARM BALL JOINT DISCONNECTION

Caution

1. Use the special tool to loosen the nut only do not remove it from the ball joint.
2. Tie the special tool with a cord not let it fall off.

◀C▶ SHIMS REMOVAL

NOTE

The camber and caster adjustment shims should be stored for reference at assembly.

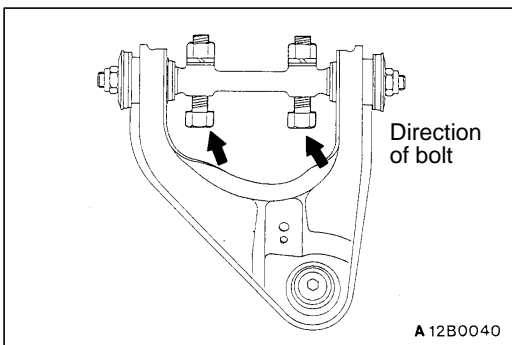

INSTALLATION SERVICE POINTS

▶A◀ UPPER ARM INSTALLATION

When the upper arm assembly is installed to the crossmember, insert the upper arm shaft attaching bolts from outside the crossmember and put adjusting shims between the crossmember and upper arm shaft.

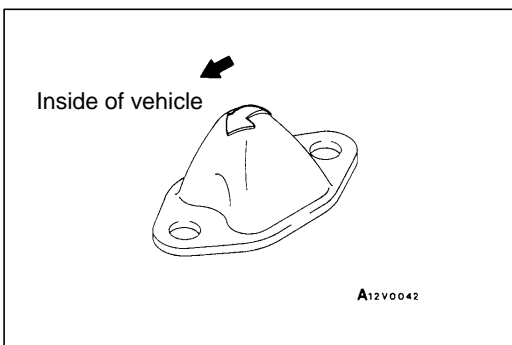

▶B◀ REBOUND STOPPER INSTALLATION

Install the rebound stopper so that its arrow faces inside of the vehicle.

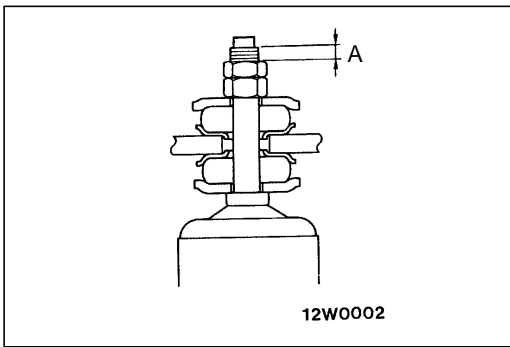

►◀ SHOCK ABSORBER INSTALLATION

Install the shock absorber so that the distance (A) shown in the illustration is at the standard value.

Standard value (A): 1 – 2 mm

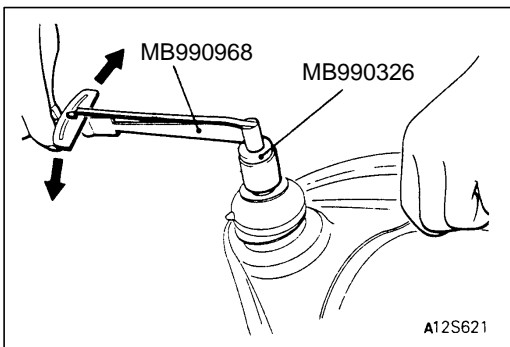

INSPECTION

33200260036

UPPER ARM BALL JOINT STARTING TORQUE CHECK

1. After shaking the upper arm ball joint assembly stud several times, install the nut to the stud and use the special tool to measure the starting torque of the upper arm ball joint assembly.

Standard value: 0.8 – 3.4 Nm

2. If the starting torque exceeds the standard value, replace the upper arm ball joint assembly.
3. If the starting torque is lower than the standard value, check that the ball joint turns smoothly without excessive play. If so, it is possible to use that ball joint.

UPPER ARM BALL JOINT DUST COVER CHECK

When dust cover is cracked or damaged, replace the upper arm ball joint assembly.

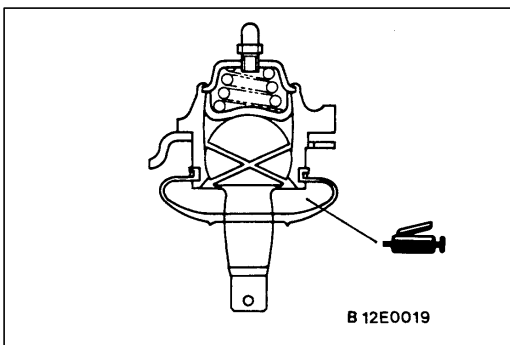

UPPER ARM BALL JOINT DUST COVER REPLACEMENT

33200800030

Only when dust cover is damaged accidentally during service work, replace the dust cover as follows:

1. Apply multipurpose grease to the interior of the dust cover and the upper arm ball joint.
2. Secure the dust cover to the upper arm ball joint with ring.

LOWER ARM, COIL SPRING AND STRUT BAR <2WD>

REMOVAL AND INSTALLATION

Pre-removal

- Under Cover Removal

Post-installation Operation

- Front Wheel Alignment Check and Adjustment (Refer to P.33A-6.)
- Under Cover Installation

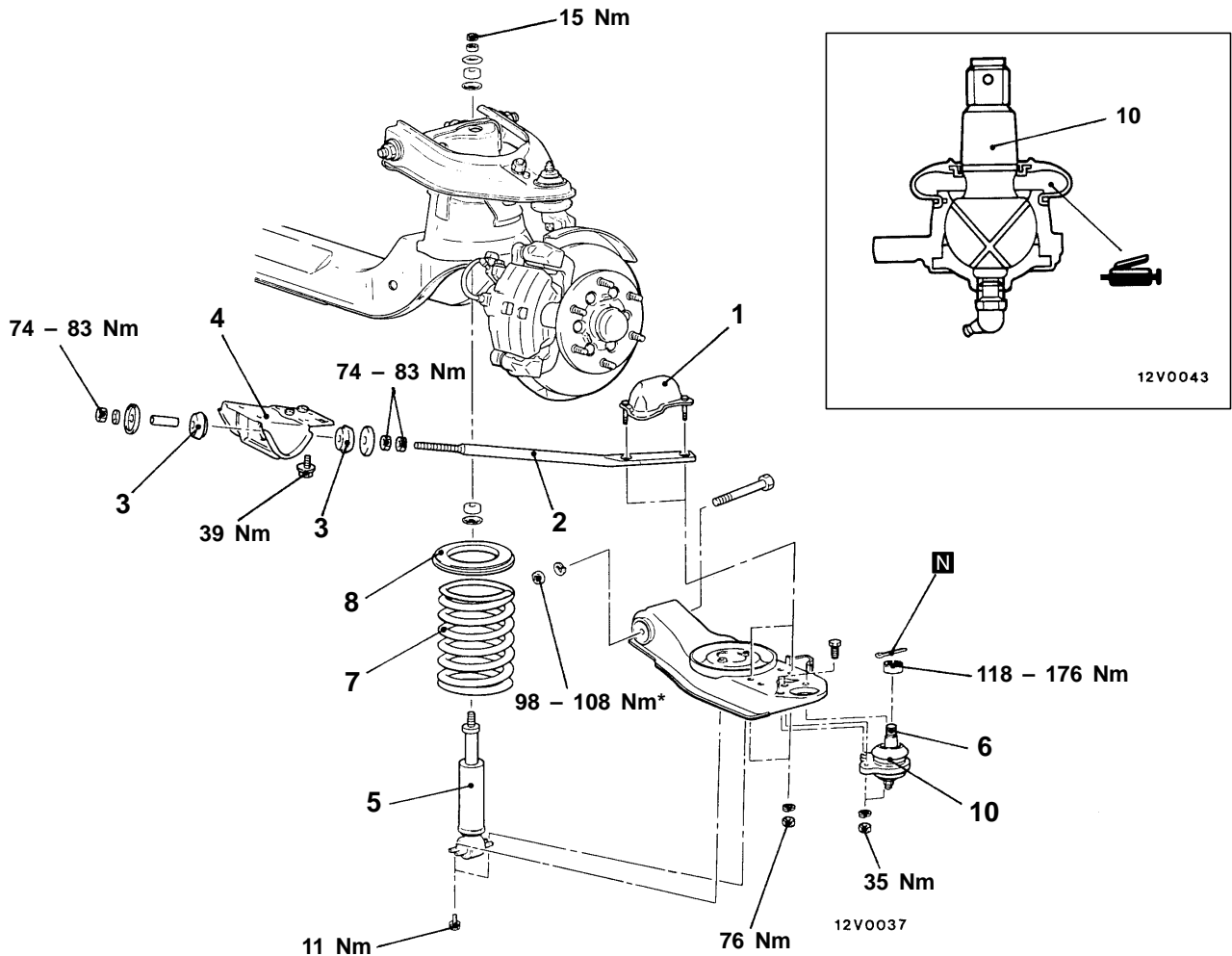

00005122

Strut bar removal steps



1. Bump stopper
2. Strut bar
3. Strut bar bushing
4. Strut bar bracket

Coil spring removal steps



1. Bump stopper
5. Shock absorber
6. Lower arm ball joint connection
7. Coil spring
8. Spring seat

Lower arm removal steps



1. Bump stopper
5. Shock absorber
6. Lower arm ball joint connection
7. Coil spring
9. Lower arm assembly
10. Lower arm ball joint assembly

Caution

*: Indicates parts which should be temporarily tightened, and then fully tightened with the vehicle on the ground in the unladen condition.

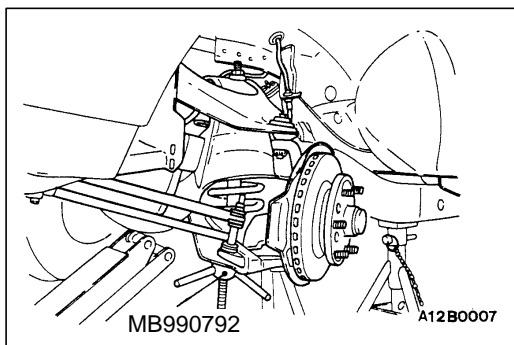

REMOVAL SERVICE POINT

◀A▶ LOWER ARM BALL JOINT DISCONNECTION

1. Install the special tool to compress the coil spring slightly.

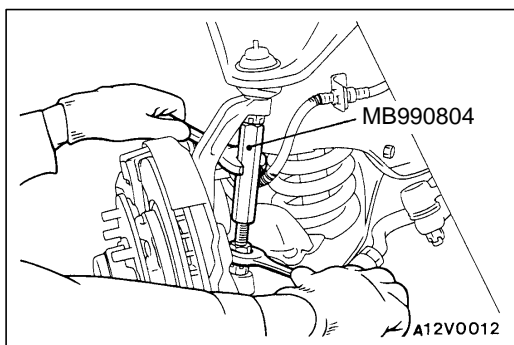

2. Use the special tool to disconnect the lower ball joint from the knuckle.

Caution

1. Use the special tool to loosen the nut only do not remove it from the ball joint.
2. Tie the special tool with a cord not let it fall off.

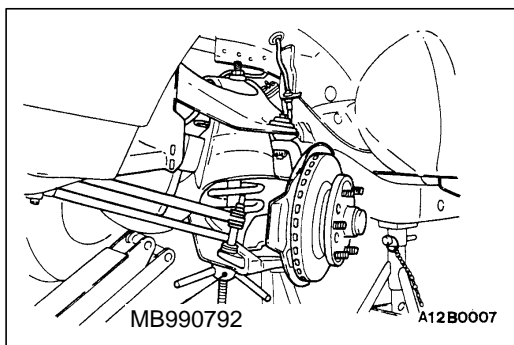

INSTALLATION SERVICE POINTS

▶A◀ COIL SPRING INSTALLATION

Compress the coil spring with the special tool and assemble the lower ball joint to knuckle.

NOTE

Compression of the coil spring will be facilitated if the lower arm is slightly lifted with a hydraulic jack fitted to the end of the lower arm.

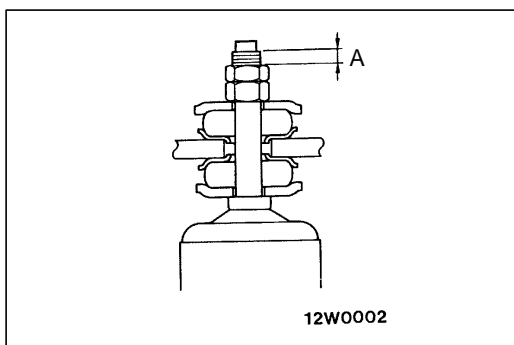

▶B◀ SHOCK ABSORBER INSTALLATION

Install the shock absorber so that the distance (A) shown in the illustration is at the standard value.

Standard value (A): 1 – 2 mm

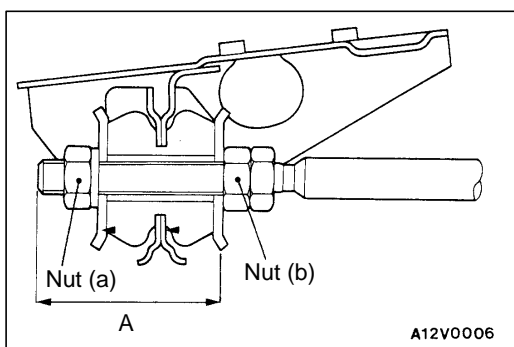

▶C◀ STRUT BAR BUSHING AND STRUT BAR INSTALLATION

1. Install the strut bar bushing so that they face in the direction shown in the illustration.
2. Tighten nut (b) so that distance (A) is at the standard value.

Standard value (A): 79 mm

3. Tighten nut (a) to the specified torque.

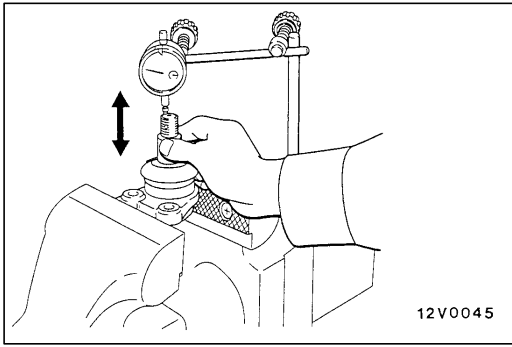

INSPECTION

33200290028

LOWER ARM BALL JOINT END PLAY

Check the lower arm ball joint assembly end play by following the steps below.

1. Measure the lower arm ball joint assembly end play with a dial indicator.

Limit: 0.5 mm

2. If the lower arm ball joint assembly end play exceeds the service limit, replace the lower arm ball joint assembly.

LOWER ARM BALL JOINT DUST COVER CHECK

When dust cover is cracked or damaged, replace the upper arm ball joint assembly.

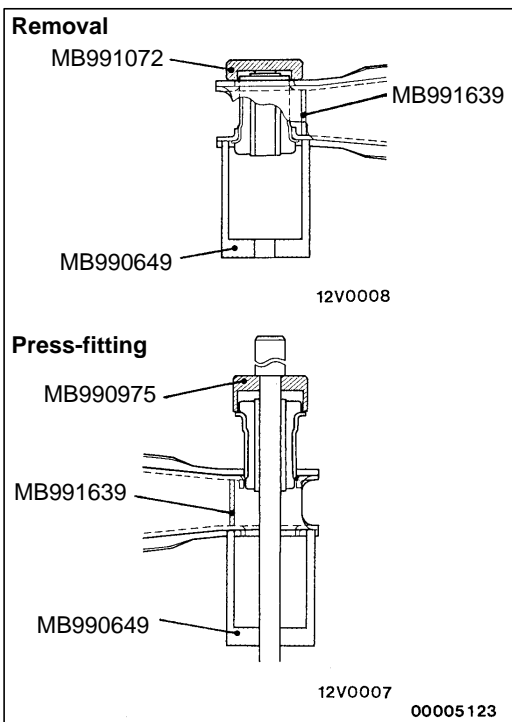

LOWER ARM BUSH REPLACEMENT

33200810040

1. Use the special tool to remove the lower arm bushing.
2. Use the special tool to press-fit the lower arm bushing until the flange of the bushing touches the lower arm.
3. Check that the press-fitting force is at the standard value while press-fitting the bushing.

Standard value: 9.8 kN

4. If the press-fitting force is less than the standard value, replace the lower arm.

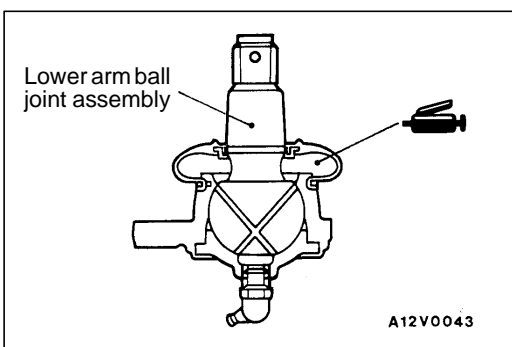

LOWER ARM BALL JOINT DUST COVER REPLACEMENT

33200820036

Only when dust cover is damaged accidentally during service work, replace the dust cover as follows:

1. Apply multipurpose grease to the interior of the dust cover and the lower arm ball joint.
2. Secure the dust cover to the lower arm ball joint with ring.

LOWER ARM AND TORSION BAR <4WD>

REMOVAL AND INSTALLATION

Pre-removal Operation

- Under Cover and Skid Plate Removal

Post-installation Operation

- Front Wheel Alignment Check and Adjustment (Refer to P.33A-6.)
- Under Cover and Skid Plate Installation

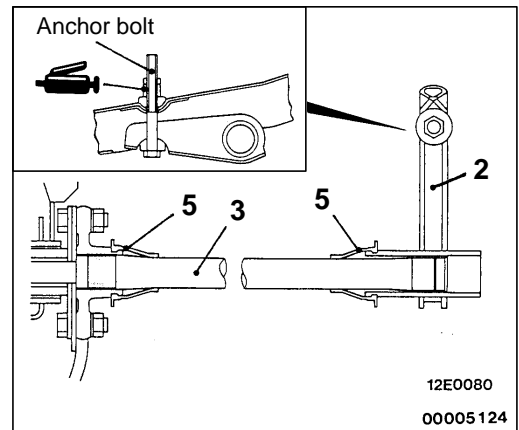
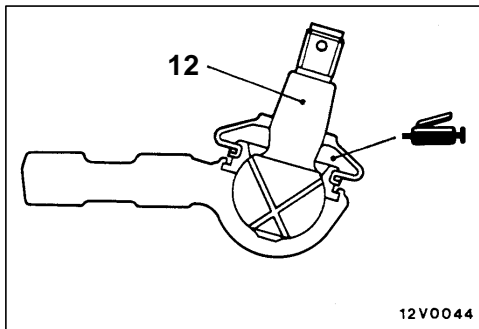
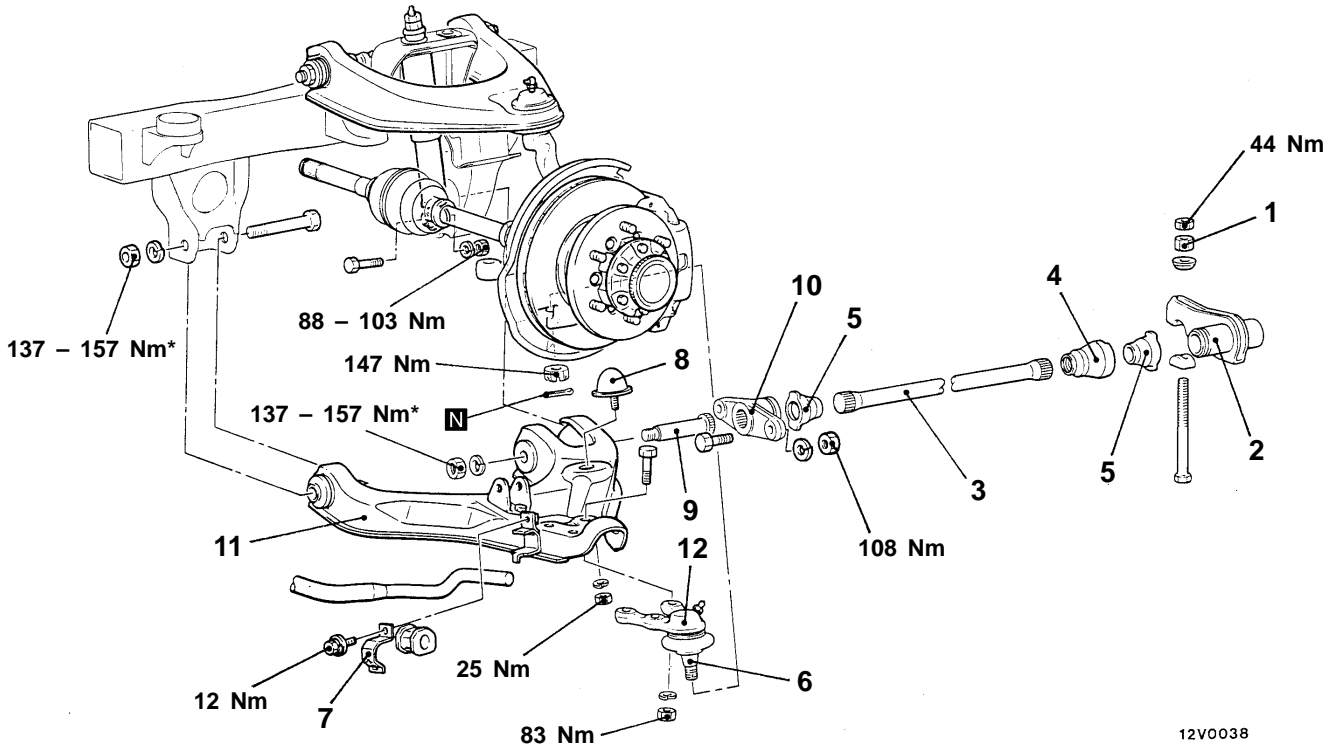

Removal steps

- ▶C◀ • Adjustment of clearance from bump stopper to bump stopper bracket
- ▶B◀ 1. Anchor arm assembly adjusting nut
- ▶A◀ 2. Anchor arm assembly
- ▶A◀ 3. Torsion bar
- ▶A◀ 4. Heat cover (right side only)
- ▶A◀ 5. Dust covers
- ◀A▶ 6. Lower arm ball joint connection
- ◀A▶ 7. Stabilizer bar connection
- ◀A▶ 8. Bump stopper

- 9. Lower arm shaft
- 10. Anchor arm B
- 11. Lower arm
- 12. Lower arm ball joint assembly

Caution

*: Indicates parts which should be temporarily tightened, and then fully tightened with the vehicle on the ground in the unladen condition.

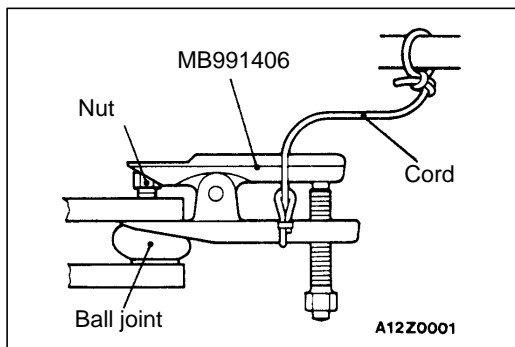

REMOVAL SERVICE POINT

◀A▶ LOWER ARM BALL JOINT DISCONNECTION

Caution

1. Use the special tool to loosen the nut only do not remove it from the ball joint.
2. Tie the special tool with a cord not let it fall off.

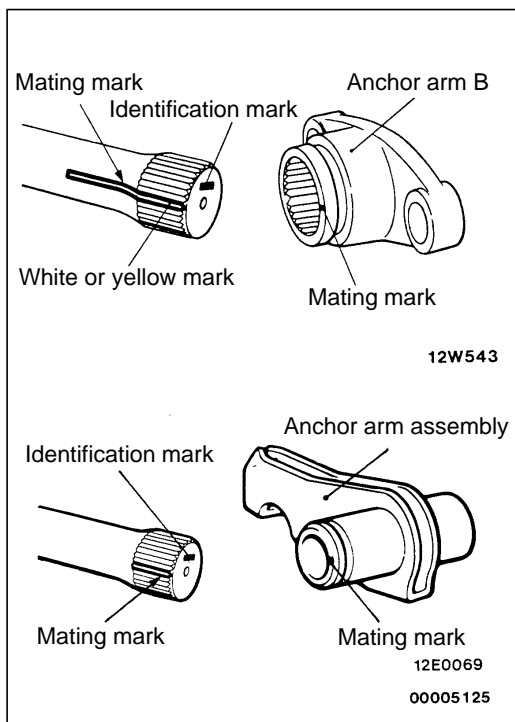

INSTALLATION SERVICE POINTS

▶A▶ TORSION BAR/ANCHOR ARM ASSEMBLY INSTALLATION

1. Check the identification marks at the end of the left and right torsion bars.
R → for right side
L → for left side
2. When installation the torsion bar, align the white mark on the serrated section of the torsion bar with the mating mark on the anchor arm.

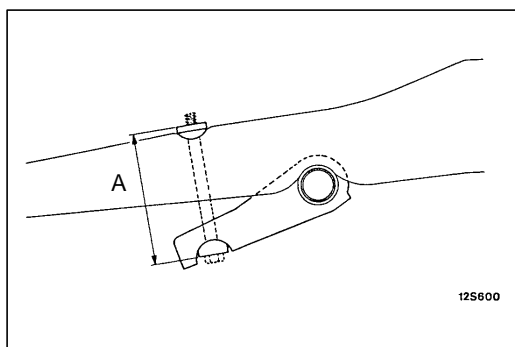

▶B▶ ANCHOR ARM ASSEMBLY ADJUSTING NUT INSTALLATION

Tighten the anchor arm assembly adjusting nut so that the distance of the anchor arm bolt shown in the illustration is at the standard value.

Standard value (A): 138 mm

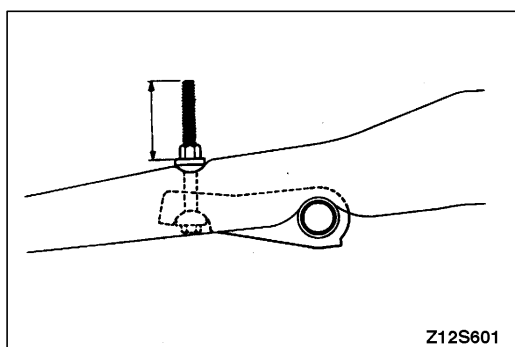

▶C▶ ADJUSTMENT OF CLEARANCE FROM BUMP STOPPER TO BUMP STOPPER BRACKET

1. Tighten the adjusting nut until the protruding length of the anchor bolt is 60 mm [53 mm] or less.

NOTE

[]: indicates option of torsion bar.

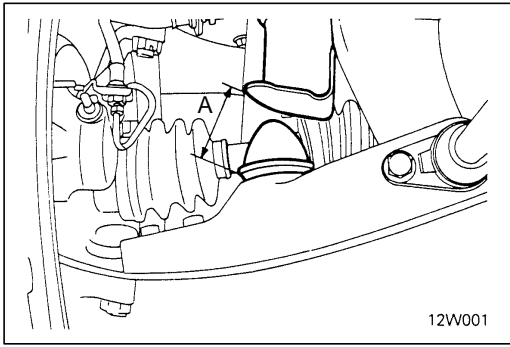

2. With the vehicle in an unladen condition, measure the distance from the bump stopper to the bump stopper bracket to check if it is at the standard value.

Standard value (A): 71 – 73 mm

3. If outside the standard value, adjust the anchor bolt with the adjusting nut.

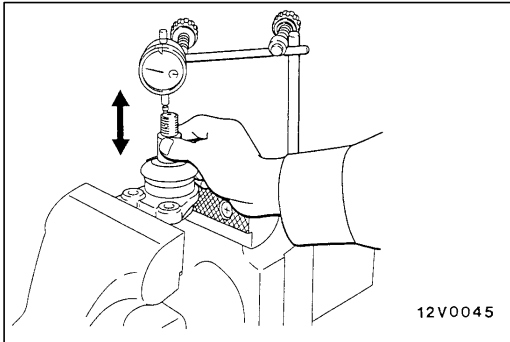

INSPECTION

33200290035

LOWER ARM BALL JOINT END PLAY

Check the lower arm ball joint assembly end play by following the steps below.

1. Measure the lower arm ball joint assembly end play with a dial indicator.

Limit: 0.5 mm

2. If the lower arm ball joint assembly end play exceeds the service limit, replace the lower arm ball joint assembly.

LOWER ARM BALL JOINT DUST COVER CHECK

When dust cover is cracked or damaged, replace the lower arm ball joint assembly.

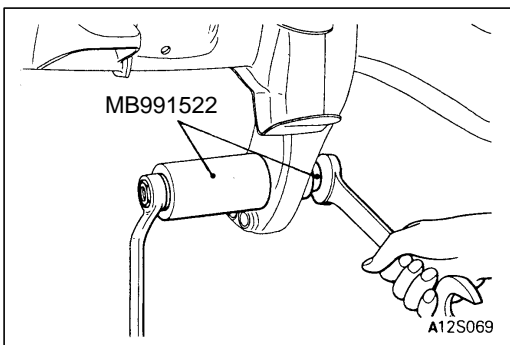

LOWER ARM BUSHING (A) REPLACEMENT

33200810057

1. Using the special tool, remove the lower arm bushing (A) from the bracket.

NOTE

When removing the left hand lower arm bushing (A), detach the differential carrier. (Refer to GROUP 26.)

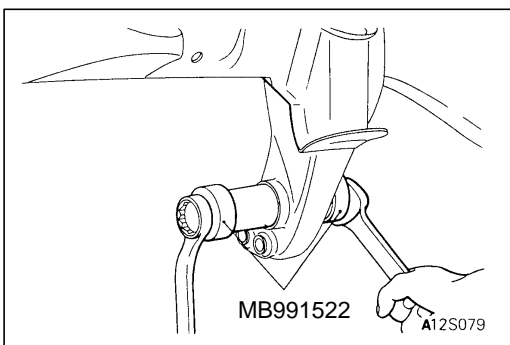

2. Using the special tool, press-fit the lower arm bushing (A) into the bracket.

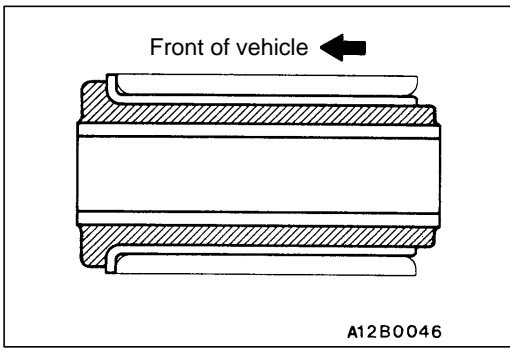

NOTE
Install the lower arm bushing (A) in a arrow direction.

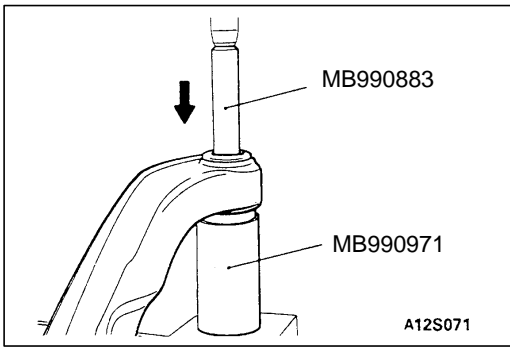

LOWER ARM BUSHING (B) REPLACEMENT

33200810064

1. Remove the lower arm bushing (B) from the lower arm by using special tools.

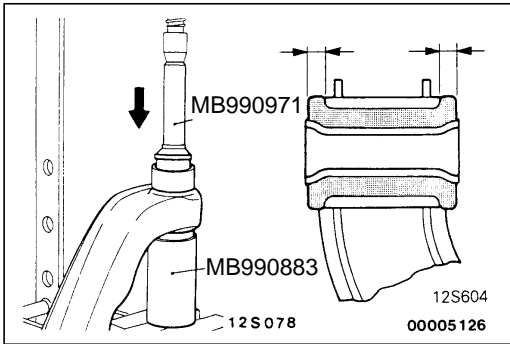

2. Coat the lower arm bushing (B) and the lower arm with soap solution and press-fit the lower arm bushing (B) into the lower arm by using special tools and taking care not to twist or tilt the lower arm bushing (B).

NOTE

Press-fit the lower arm bushing (B) again from the opposite side to equalize bushing projections at both ends.

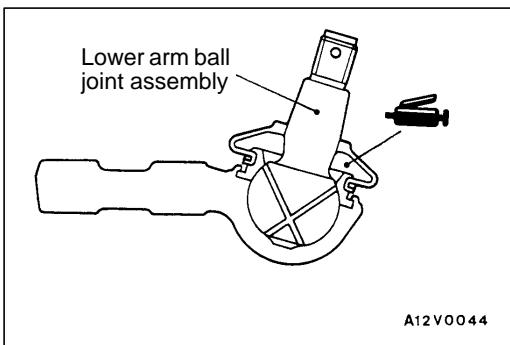

LOWER ARM BALL JOINT DUST COVER REPLACEMENT

33200820043

Only when dust cover is damaged accidentally during service work, replace the dust cover as follows:

1. Apply multipurpose grease to the interior of the dust cover and the lower arm ball joint.
2. Secure the dust cover to the lower arm ball joint with ring.

STABILIZER BAR <4WD>**REMOVAL AND INSTALLATION****Pre-removal and Post-installation Operation**

- Under Cover and Skid Plate Removal and Installation

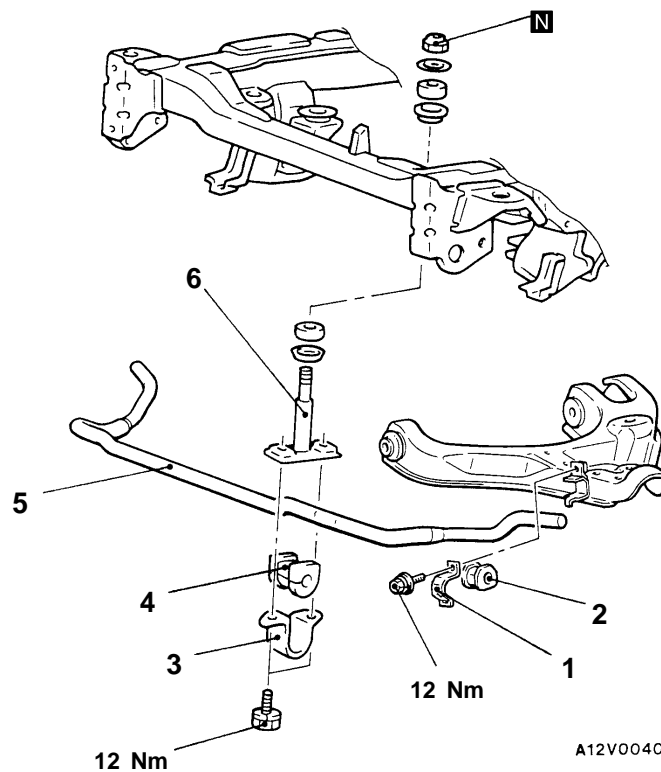
**Removal steps**

- A◄ • Stabilizer link assembly mounting nut adjustment
- | | |
|---------------------------|-----------------------------|
| 1. Stabilizer bracket (A) | 3. Stabilizer bracket |
| 2. Bushing | 4. Bushing |
| | 5. Stabilizer bar |
| | 6. Stabilizer link assembly |

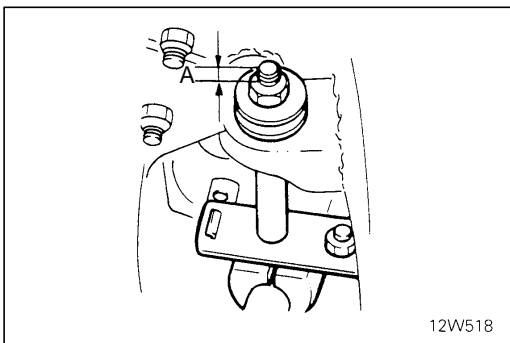

12W518

INSTALLATION SERVICE POINT**►A◄ STABILIZER LINK ASSEMBLY MOUNTING NUT ADJUSTMENT**

Tighten the nut so that the dimensions shown in the figure are at standard value.

Standard value (A): 16 – 18 mm

NOTES