

ENGINE

4G6 SERIES

<1991 to 1992>

CONTENTS

GENERAL INFORMATION	11A- 0-3
1. SPECIFICATIONS	11A- 1-1
GENERAL SPECIFICATIONS	11A- 1-1
SERVICE SPECIFICATIONS	11A- 1-4
TORQUE SPECIFICATIONS	11A-1-11
SEALANT	11A-1-14
2. SPECIAL TOOLS	11A- 2-1
3. TIMING BELT (SINGLE CAMSHAFT ENGINE)	11A- 3-1
4. TIMING BELT (DOUBLE CAMSHAFT ENGINE)	11A- 4-1
5. INTAKE MANIFOLD	11A- 5-1
6. EXHAUST MANIFOLD AND WATER PUMP	11A- 6-1
7. TURBOCHARGER	11A- 7-1
8. ROCKER ARMS AND CAMSHAFT (SINGLE CAMSHAFT ENGINE)	11A- 8-1
9. CAMSHAFTS AND ROCKER ARMS (DOUBLE CAMSHAFT ENGINE)	11A- 9-1
10. ROCKER ARMS AND ROCKER SHAFTS (SINGLE CAMSHAFT ENGINE)	11A-10-1
11. CYLINDER HEAD AND VALVES (SINGLE CAMSHAFT ENGINE)	11A-11-1
12. CYLINDER HEAD AND VALVES (DOUBLE CAMSHAFT ENGINE)	11A-12-1
13. FRONT CASE, SILENT SHAFT AND OIL PAN	11A-13-1
14. PISTON AND CONNECTING ROD	11A-14-1
15. CRANKSHAFT, FLYWHEEL AND DRIVE PLATE	11A-15-1
16. CYLINDER BLOCK	11A-16-1

GENERAL INFORMATION

ENGINE SECTIONAL VIEW – SINGLE CAMSHAFT ENGINE

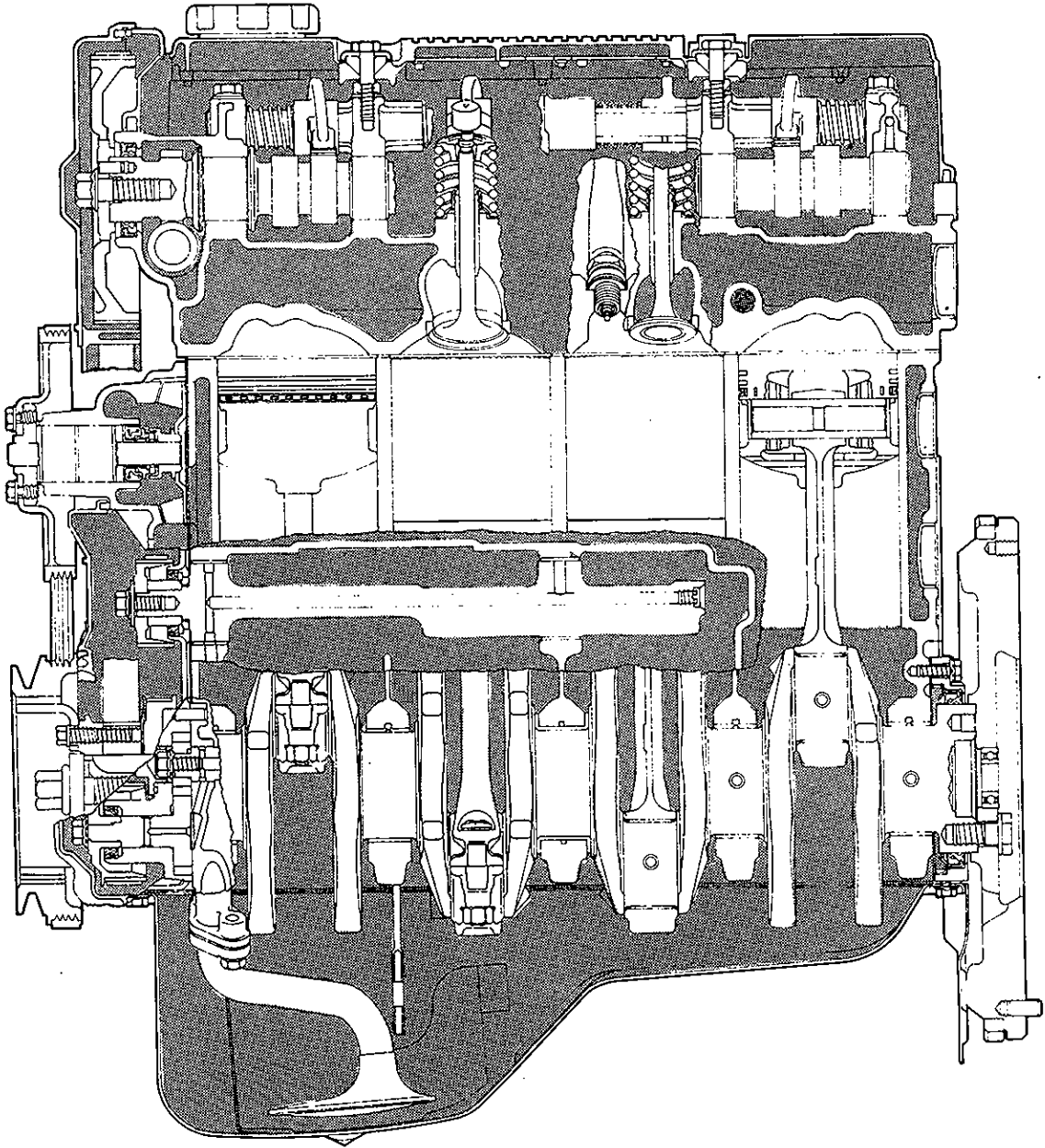

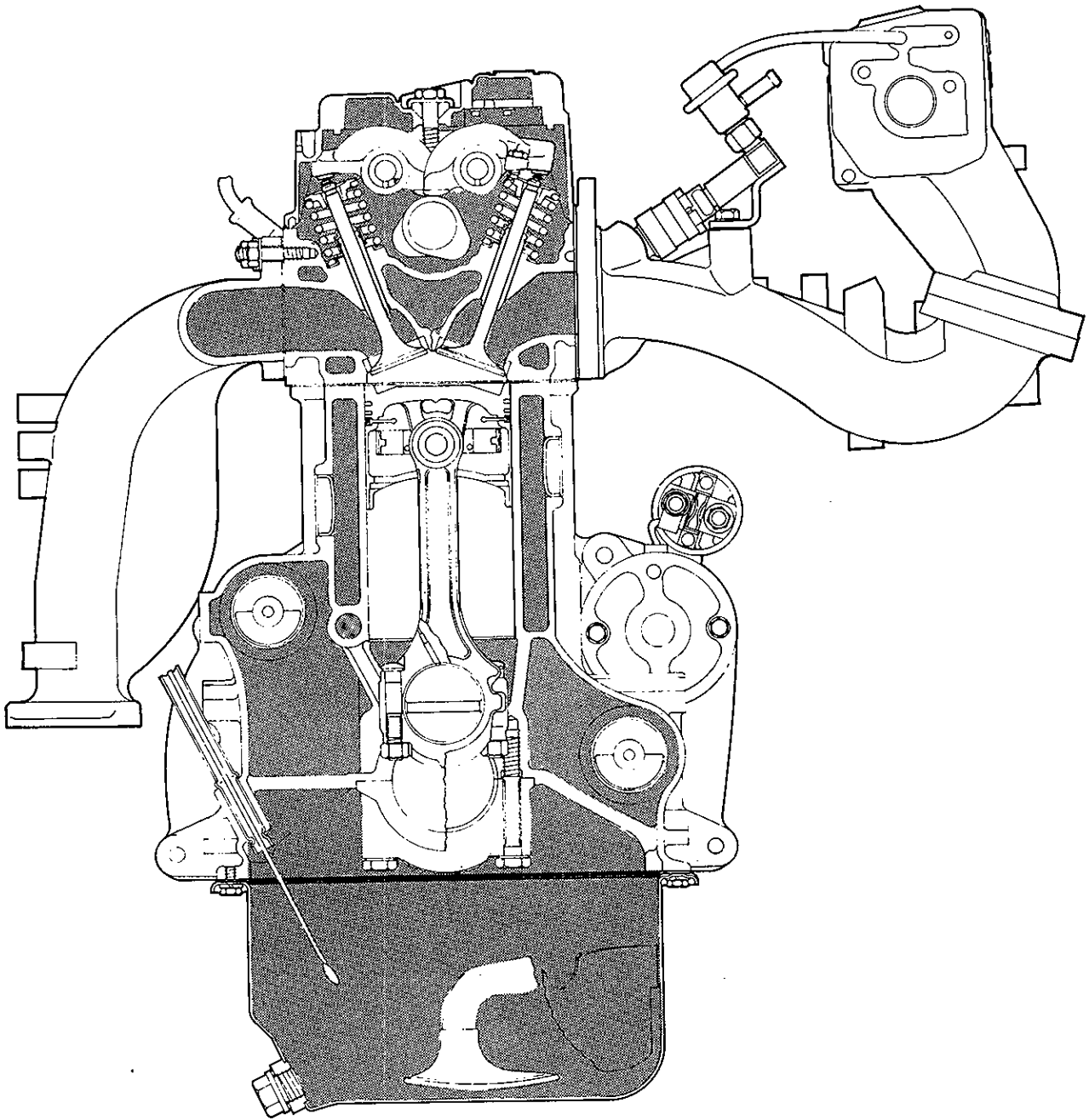

ENGINE SECTIONAL VIEW – DOUBLE CAMSHAFT ENGINE

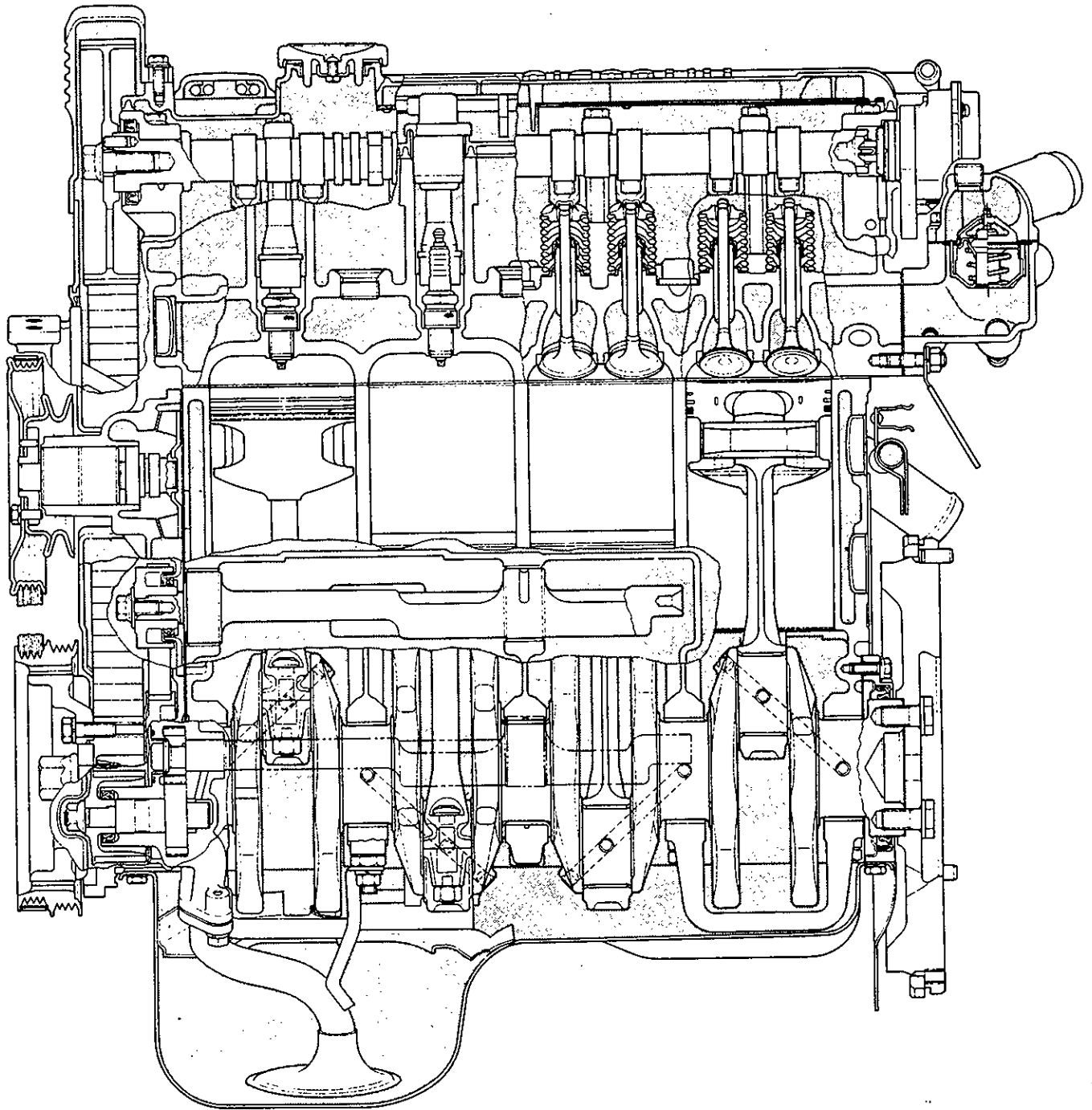

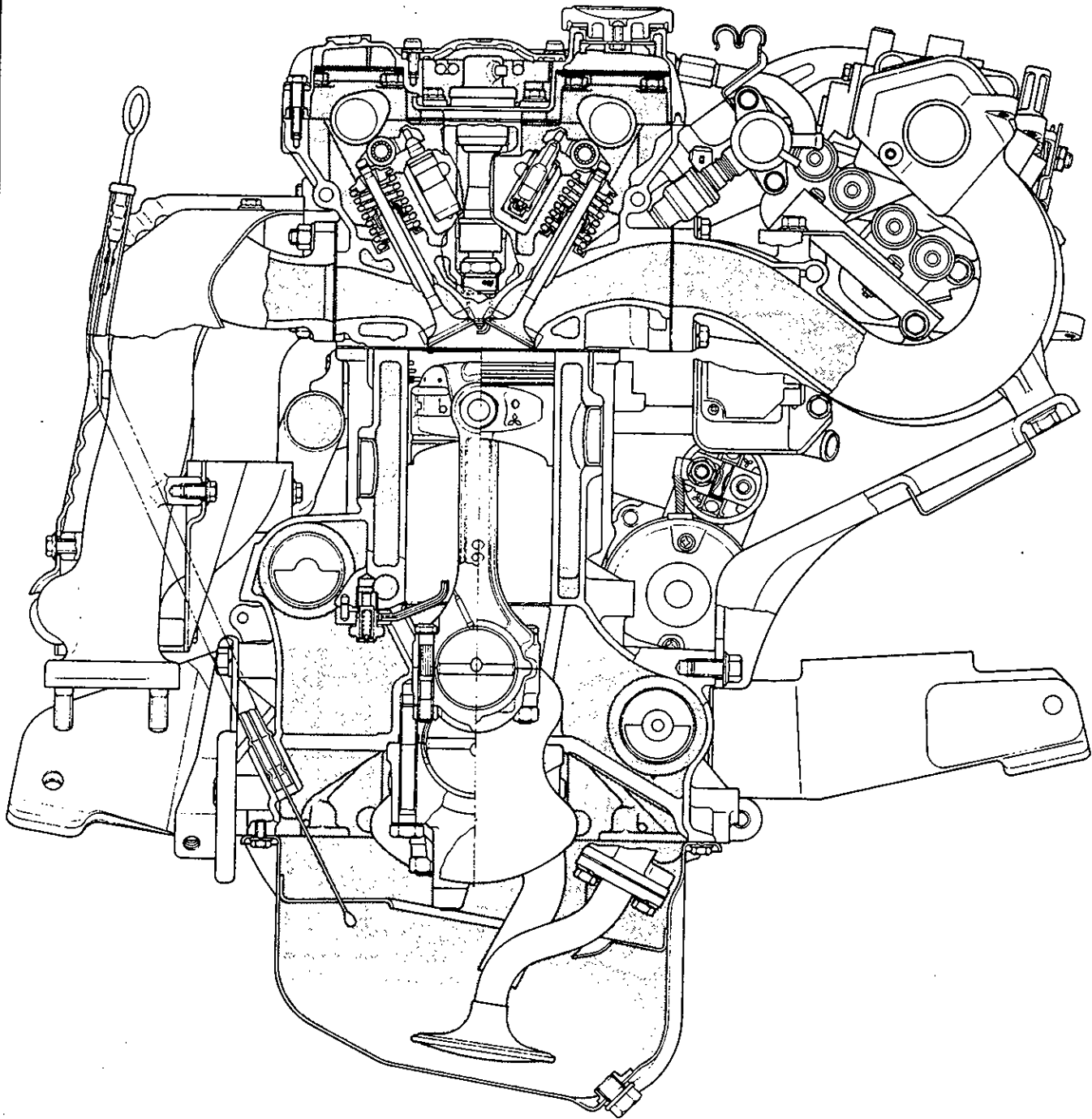

ENGINE LUBRICATION SYSTEM – SINGLE CAMSHAFT ENGINE

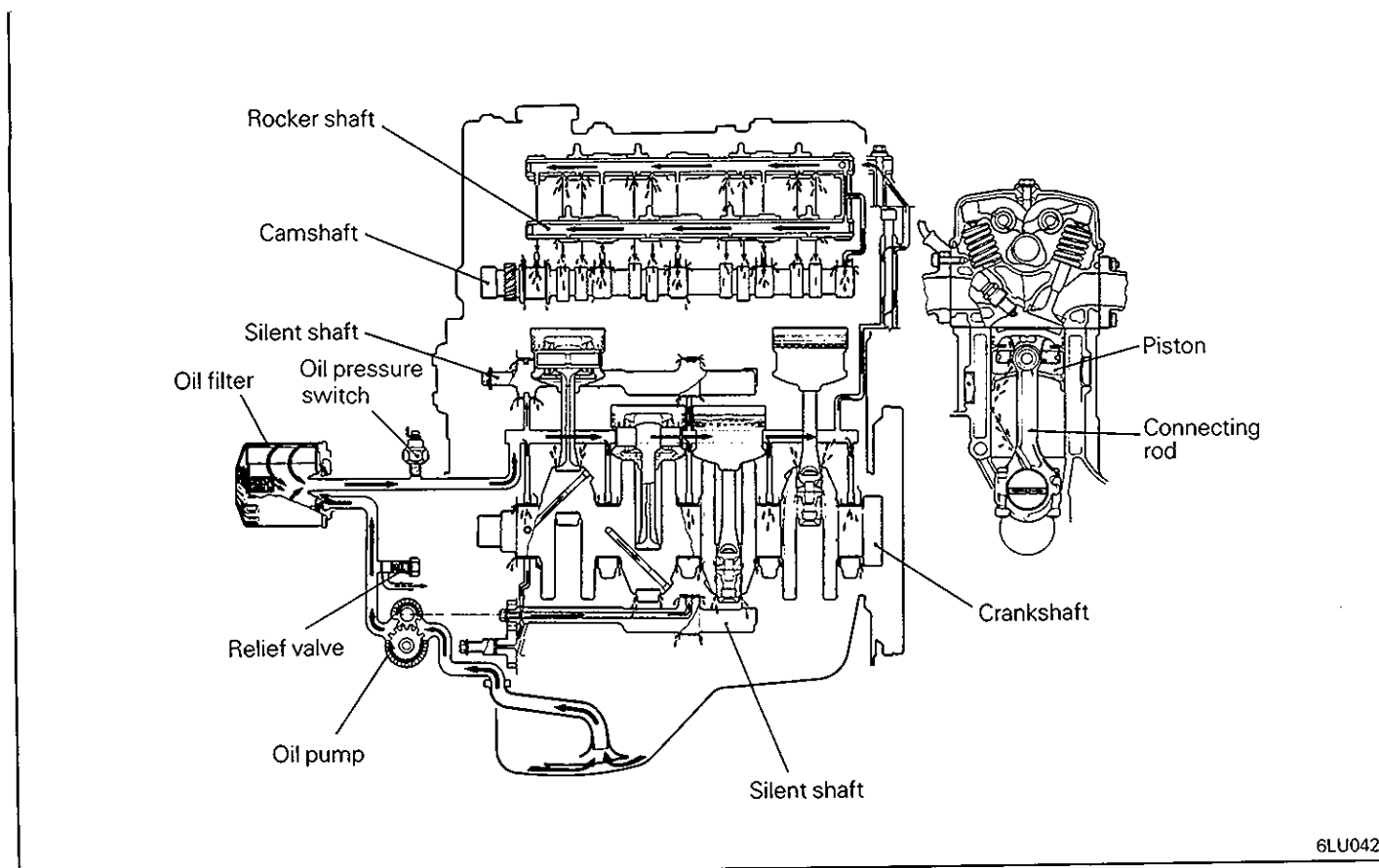

ENGINE LUBRICATION SYSTEM – DOUBLE CAMSHAFT ENGINE

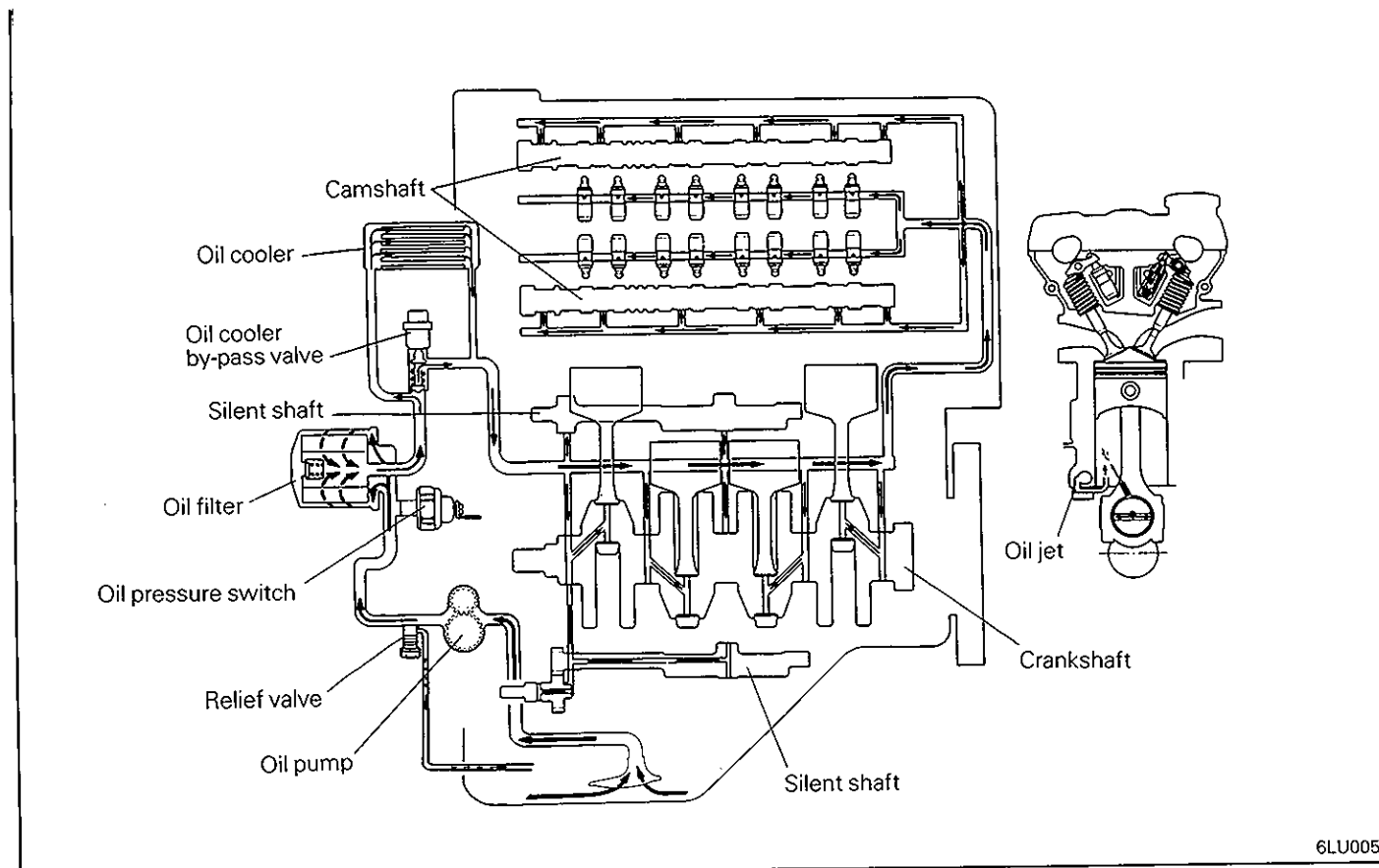

ENGINE LUBRICATION SYSTEM – DOUBLE CAMSHAFT ENGINE WITH TURBOCHARGER

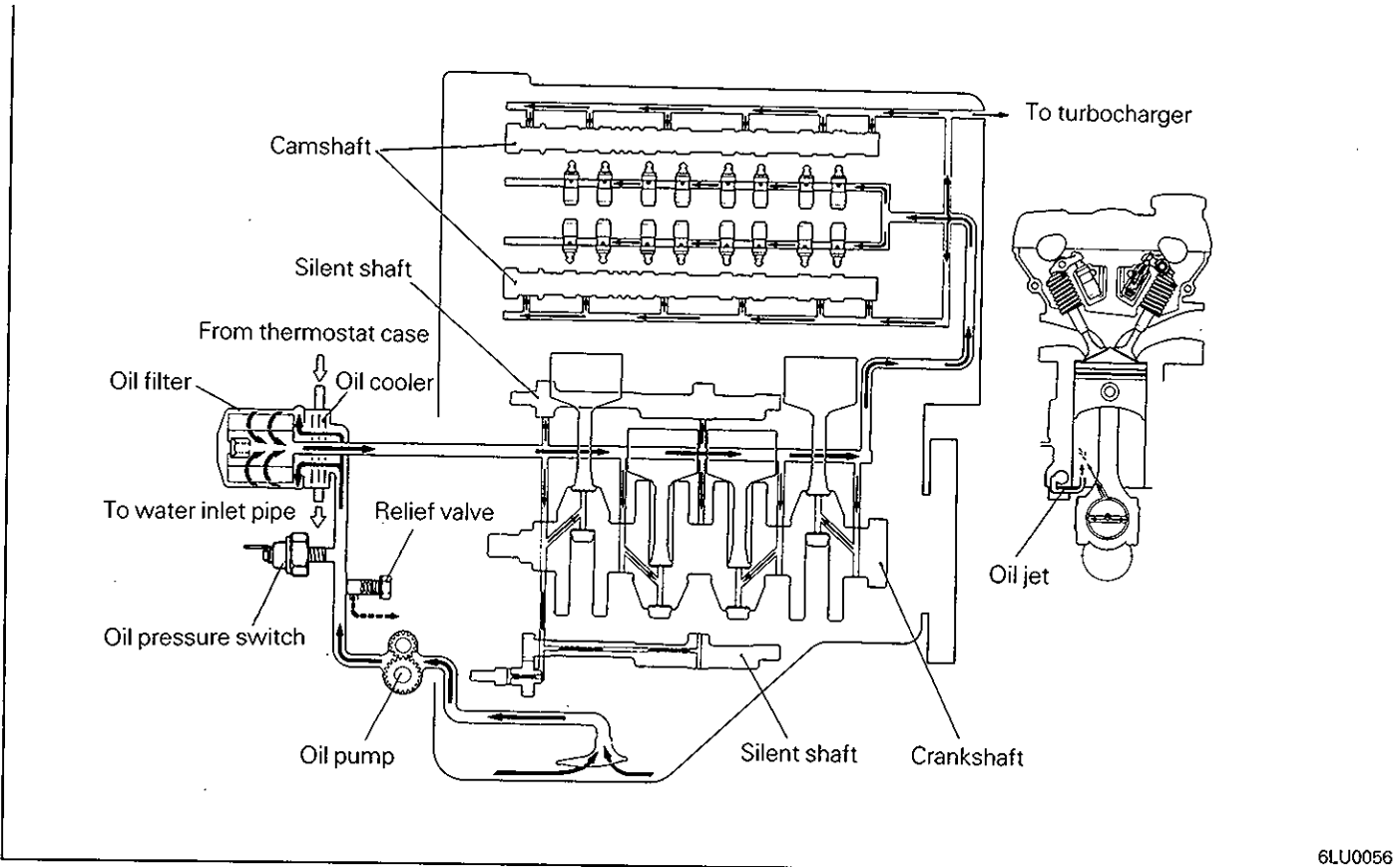

6LU0056

1. SPECIFICATIONS

GENERAL SPECIFICATIONS

4G63 ENGINE WITH SINGLE CAMSHAFT

No. and arrangement of cylinder	4, in-line			
Combustion chamber	Compact type			
Total displacement	1,997 cc (121.9 cu.in.)			
Cylinder bore x stroke	85 x 88 mm (3.35 x 3.46 in.)			
Compression ratio	8.5 or 9.0 or 9.5 (Specs. varies according to engine model)			
Valve mechanism	Single overhead camshaft			
Lash adjuster (if so equipped)	Hydraulic type			
Rocker arm	Slipper type or Roller follower type			
Valve timing				
() : camshaft identification mark	(A,AR,1)	(C,3)	(D)	
Intake valve	Open BTDC	19°	20°	20°
	Close ABDC	57°	68°	64°
Exhaust valve	Open BBDC	57°	62°	64°
	Close ATDC	19°	26°	20°

4G64 ENGINE with SINGLE CAMSHAFT

No. and arrangement of cylinder	4, in-line			
Combustion chamber	Compact type			
Total displacement	2,350 cc (143.4 cu.in.)			
Cylinder bore x stroke	86.5 x 100 mm (3.35 x 3.46 in.)			
Compression ratio	8.5 or 8.8 (Specs. varies according to engine model)			
Valve mechanism	Single overhead camshaft			
Lash adjuster	Hydraulic type			
Rocker arm	Slipper type			
Valve timing				
() : camshaft identification mark	(D)	(E)	(1)	
Intake valve	Open BTDC	20°	20°	19°
	Close ABDC	64°	68°	57°
Exhaust valve	Open BBDC	64°	68°	57°
	Close ATDC	20°	20°	19°

4G61 ENGINE with DOUBLE CAMSHAFT

No. and arrangement of cylinder	4, in-line				
Combustion chamber	Pentroof type				
Total displacement	1,595 cc (97.3 cu.in.)				
Cylinder bore x stroke	82.3 x 75 mm (3.24 x 2.95 in.)				
Compression ratio	9.2 or 10.0 (Specs. varies according to engine model)				
Valve mechanism	Double overhead camshaft				
Lash adjuster	Hydraulic type				
Rocker arm	Roller follower type				
Valve timing					
(): camshaft identification mark			(D)		(E)
Intake valve	Open	BTDC	21°		16°
	Close	ABDC	51°		48°
Exhaust valve	Open	BBDC	54°		43°
	Close	ATDC	17°		17°

4G63 ENGINE with DOUBLE CAMSHAFT

No. and arrangement of cylinder	4, in-line					
Combustion chamber	Pentroof type					
Total displacement	1,997 cc (121.9 cu.in.)					
Cylinder bore x stroke	85 x 88 mm (3.35 x 3.46 in.)					
Compression ratio	7.8 or 9.0 or 9.8 or 10.4 (Specs. varies according to engine model)					
Valve mechanism	Double overhead camshaft					
Lash adjuster	Hydraulic type					
Rocker arm	Roller follower type					
Valve timing						
(): camshaft identification mark			(A)	(C)	(D)	(G)
Intake valve	Open	BTDC	26°	23°	21°	18°
	Close	ABDC	46°	57°	51°	62°
Exhaust valve	Open	BBDC	55°	57°	–	63°
	Close	ATDC	9°	15°	–	21°

40

4G67 ENGINE with DOUBLE CAMSHAFT

No. and arrangement of cylinder	4, in-line
Combustion chamber	Pentroof type
Total displacement	1,836 cc (112.0 cu.in.)
Cylinder bore x stroke	81.5 x 88 mm (3.21 x 3.46 in.)
Compression ratio	10.5
Valve mechanism	Double overhead camshaft
Lash adjuster	Hydraulic type
Rocker arm	Roller follower type
Valve timing	
(): camshaft identification mark	(G)
Intake valve	
Open	BTDC
Close	ABDC
Exhaust valve	
Open	BBDC
Close	ATDC

SERVICE SPECIFICATIONS

mm (in.)

	Standard	Limit
Cylinder head – Single camshaft engine		
Flatness of gasket surface	0.05 (0.0020)	0.2 (0.008)
Grinding limit		*0.2 (0.008)
* Includes/Combined with cylinder block grinding.		
Flatness of manifold mounting surface	0.15 (0.0059)	0.3 (0.012)
Overall height	89.9 – 90.1 (3.539 – 3.547)	
Oversize rework dimensions of valve guide hole (both intake and exhaust)		
0.05	13.05 – 13.07 (0.5138 – 0.5146)	
0.25	13.25 – 13.27 (0.5217 – 0.5224)	
0.50	13.50 – 13.52 (0.5315 – 0.5323)	
Oversize rework dimensions of intake valve seat ring hole		
0.30	4G63 44.30 – 44.33 (1.7441 – 1.7453)	
	4G64 47.30 – 47.33 (1.8622 – 1.8634)	
0.60	4G63 44.60 – 44.63 (1.7559 – 1.7571)	
	4G64 47.60 – 47.63 (1.8740 – 1.8752)	
Oversize rework dimensions of exhaust valve seat ring hole		
0.30	4G63 38.30 – 38.33 (1.5079 – 1.5091)	
	4G64 40.30 – 40.33 (1.5866 – 1.5878)	
0.60	4G63 38.60 – 38.63 (1.5197 – 1.5209)	
	4G64 40.60 – 40.63 (1.5984 – 1.5996)	
Cylinder head – Double camshaft engine		
Flatness of gasket surface	0.05 (0.0020)	0.2 (0.008)
Grinding limit		*0.2 (0.008)
* Includes/Combined with cylinder block grinding.		
Flatness of manifold mounting surface	0.15 (0.0059)	0.3 (0.012)
Overall height	131.9 – 132.1 (5.193 – 5.201)	
Oversize rework dimensions of valve guide hole (both intake and exhaust)		
0.05	12.05 – 12.07 (0.4744 – 0.4752)	
0.25	12.25 – 12.27 (0.4823 – 0.4831)	
0.50	12.50 – 12.52 (0.4921 – 0.4929)	
Oversize rework dimensions of intake valve seat ring hole		
0.30	35.30 – 35.33 (1.3898 – 1.3909)	
0.60	35.60 – 35.63 (1.4016 – 1.4028)	
Oversize rework dimensions of exhaust valve seat ring hole		
0.30	33.30 – 33.33 (1.3110 – 1.3122)	
0.60	33.60 – 33.63 (1.3228 – 1.3240)	

mm (in.)

		Standard	Limit
Camshaft – Single camshaft engine			
Identification mark: 1			
Cam height	Intake	42.17 (1.6602)	41.67 (1.6405)
	Exhaust	42.23 (1.6626)	41.73 (1.6429)
Identification mark: 3			
Cam height	Intake	42.48 (1.6724)	41.98 (1.6528)
	Exhaust	42.55 (1.6752)	42.05 (1.6555)
Identification mark: A			
Cam height	Intake	42.08 (1.6567)	41.58 (1.6370)
	Exhaust	42.08 (1.6567)	41.58 (1.6370)
Identification mark: C, D, E			
Cam height	Intake	42.40 (1.6693)	41.90 (1.6496)
	Exhaust	42.40 (1.6693)	41.90 (1.6496)
Identification mark: AR			
Cam height	Intake	44.53 (1.7531)	44.03 (1.7335)
	Exhaust	44.53 (1.7531)	44.03 (1.7335)
NOTE: The camshaft identification mark is stamped on the rear end of the camshaft.			
Fuel pump driving cam diameter		38 (1.50)	
Journal diameter		33.94 – 33.95 (1.3362 – 1.3366)	
Oil clearance		0.05 – 0.09 (0.0020 – 0.0035)	
End play		0.1 – 0.2 (0.004 – 0.008)	
Camshaft – Double camshaft engine			
Identification mark: A			
Cam height	Intake	35.49 (1.3972)	34.99 (1.3776)
	Exhaust	35.20 (1.3858)	34.70 (1.3661)
Identification mark: C			
Cam height	Intake	35.79 (1.4091)	35.29 (1.3894)
	Exhaust	35.49 (1.3972)	34.99 (1.3776)
Identification mark: D			
Cam height	Intake	35.49 (1.3972)	34.99 (1.3776)
	Exhaust	35.49 (1.3972)	34.99 (1.3776)
Identification mark: E			
Cam height	Intake	35.20 (1.3858)	34.70 (1.3661)
	Exhaust	34.91 (1.3744)	34.41 (1.3547)
Identification mark: G			
Cam height	Intake	35.79 (1.4091)	35.29 (1.3894)
	Exhaust	35.49 (1.3972)	34.99 (1.3776)
NOTE: The camshaft identification mark is stamped on the rear end of the camshaft.			
Journal diameter		25.95 – 25.97 (1.0217 – 1.0224)	
Oil clearance		0.05 – 0.09 (0.0020 – 0.0035)	
End play		0.1 – 0.2 (0.004 – 0.008)	0.4 (0.016)

mm (in.)

	Standard	Limit
Rocker arm – Single camshaft engine		
I.D.	18.91 – 18.93 (0.7445 – 0.7453)	
Rocker arm-to-shaft clearance	0.01 – 0.04 (0.0004 – 0.0016)	0.1 (0.004)
Ash adjuster		
Leak down test	4 – 20 seconds/1 mm (0.04 in.)	
Remarks: Diesel fuel at 15 – 20°C (59 – 68°F)		
Rocker shaft – Single camshaft engine		
O.D.	18.89 – 18.90 (0.7437 – 0.7441)	
Overall length		
Intake	385.5 (15.177)	
Exhaust	372.5 (14.665)	
Valve – Single camshaft engine		
Overall length		
Intake		
4G63	109.8 (4.323)	
4G64	106.6 (4.197)	
Exhaust		
4G63	108.7 (4.280)	
4G64	105.2 (4.142)	
Stem diameter		
Intake	7.96 – 7.98 (0.3134–0.3142)	
Exhaust	7.93 – 7.95 (0.3122–0.3130)	
Face angle	45° – 45°30'	
Thickness of valve head (margin)		
Intake	1.2 (0.047)	0.7 (0.028)
Exhaust	2.0 (0.079)	1.5 (0.059)
Stem-to guide clearance		
Intake	0.02 – 0.06 (0.0008 – 0.0024)	0.10 (0.004)
Exhaust	0.05 – 0.09 (0.0020 – 0.0035)	0.15 (0.006)
Valve – Double camshaft engine		
Overall length		
Intake	109.5 (4.311)	
Exhaust	109.7 (4.319)	
Stem diameter		
Intake	6.57 – 6.58 (0.2587 – 0.2591)	
Exhaust	6.53 – 6.55 (0.2571 – 0.2579)	
Face angle	45° – 45°30'	
Thickness of valve head (margin)		
Intake	1.0 (0.039)	0.7 (0.028)
Exhaust	1.5 (0.059)	1.0 (0.039)
Stem-to guide clearance		
Intake	0.02 – 0.05 (0.0008 – 0.0020)	0.10 (0.004)
Exhaust	0.05 – 0.09 (0.0020 – 0.0035)	0.15 (0.006)
Valve spring – Identification color: green		
Free height	47.5 (1.869)	46.5 (1.829)
Load/installed height		
N (kg, lbs.) /mm (in.)	276 (27.6, 61)/40.4 (1.591)	
Out-of-squareness	2° or less	Max. 4°
Valve spring – Identification color: white		
Free height	49.8 (1.961)	48.8 (1.921)
Load/installed height		
N (kg, lbs.) /mm (in.)	329 (32.9, 73)/40.4 (1.591)	
Out-of-squareness	2° or less	Max. 4°
Valve spring – Identification color: blue		
Free height	48.3 (1.902)	47.4 (1.866)
Load/installed height		
N (kg, lbs.) /mm (in.)	300 (30, 66)/40 (1.57)	
Out-of-squareness	1.5° or less	Max. 4°

mm (in.)

		Standard	Limit
Valve guide – Single camshaft engine			
Overall length	Intake	47 (1.85)	
	Exhaust	52 (2.05)	
I.D.		8.00 – 8.02 (0.3150 – 0.3157)	
O.D.		13.06 – 13.07 (0.5142 – 0.5146)	
Service size		0.05 (0.002), 0.25 (0.010), 0.50 (0.020) over size	
Press-in temperature		Room temperature	
Valve guide – Double camshaft engine			
Overall length	Intake	45.5 (1.791)	
	Exhaust	50.5 (1.988)	
I.D.		6.60 – 6.62 (0.2598 – 0.2606)	
O.D.		12.06 – 12.07 (0.4748 – 0.4752)	
Service size		0.05 (0.002), 0.25 (0.010), 0.50 (0.020) over size	
Press-in temperature		Room temperature	
Valve seat			
Seat angle		43°30' – 44°	
Valve contact width		0.9 – 1.3 (0.035–0.051)	
Sinkage			0.2 (0.008)
Service size		0.3 (0.012), 0.6 (0.024) over size	
Silent shaft			
Journal diameter	Right (front)	41.96 – 41.98 (1.6520 – 1.6528)	
	(rear)	40.95 – 40.97 (1.6122 – 1.6130)	
	Left (front)	18.47 – 18.48 (0.7272 – 0.7276)	
	(rear)	40.95 – 40.97 (1.6122 – 1.6130)	
Oil clearance	Right (front)	0.03 – 0.06 (0.0012 – 0.0024)	
	(rear)	0.05 – 0.09 (0.0020 – 0.0036)	
	Left (front)	0.02 – 0.05 (0.0008 – 0.0020)	
	(rear)	0.05 – 0.09 (0.0020 – 0.0036)	
Piston – Single camshaft engine			
O.D.	4G63 – CARB	84.98 – 85.01 (3.3457 – 3.3468)	
	4G63 – MPI	84.97 – 85.00 (3.3453 – 3.3465)	
	4G64	86.47 – 86.50 (3.404 – 3.4055)	
Piston to cylinder clearance	4G63 – CARB	0.01 – 0.03 (0.0004 – 0.0012)	
	4G63 – MPI, 4G64	0.02 – 0.04 (0.0008 – 0.0016)	
Ring groove width	No. 1 ring	1.52 – 1.54 (0.0598 – 0.0606)	
	No. 2 ring	1.51 – 1.53 (0.0594 – 0.0602)	
Service size		0.25 (0.010), 0.50 (0.020), 0.75 (0.030), 1.00 (0.039) over size	

	Standard	Limit
Piston – Double camshaft engine		
O.D.	4G61 82.27 – 82.30 (3.2390 – 3.2401)	
	4G67 81.47 – 81.50 (3.2075 – 3.2087)	
	4G63 84.97 – 85.00 (3.3453 – 3.3465)	
	4G63 – Turbo 84.96 – 84.99 (3.3449 – 3.3461)	
Piston to cylinder clearance	None turbo 0.02 – 0.04 (0.0008 – 0.0016)	
	Turbo 0.03 – 0.05 (0.0012 – 0.0020)	
Ring groove width	No. 1 ring 1.22 – 1.24 (0.0480 – 0.0488)	
	No. 2 ring 1.52 – 1.54 (0.0598 – 0.0606)	
	Oil ring 3.01 – 3.03 (0.1185 – 0.1193)	
Service size	0.25 (0.010), 0.50 (0.020), 0.75 (0.030), 1.00 (0.039) over size	
Piston ring – Single camshaft engine		
End gap	No. 1 ring 0.25 – 0.40 (0.0098 – 0.0157)	0.8 (0.031)
	No. 2 ring	
	4G63 – Carburetor 0.20 – 0.35 (0.0079 – 0.0138)	0.8 (0.031)
	4G63 – Fuel injection 0.45 – 0.60 (0.0177 – 0.0236)	0.8 (0.031)
	4G64 0.20 – 0.48 (0.0130 – 0.0189)	0.8 (0.031)
	Oil ring 0.2 – 0.7 (0.0079 – 0.0276)	1.0 (0.039)
Ring-to-ring groove clearance	No. 1 ring 0.03–0.07 (0.0012–0.0028)	0.1 (0.004)
	No. 2 ring 0.02–0.06 (0.0008–0.0024)	0.1 (0.004)
Service size	0.25 (0.010), 0.50 (0.020), 0.75 (0.030), 1.00 (0.039) over size	
Piston ring – Double camshaft engine		
End gap	No. 1 ring 0.25 – 0.40 (0.0098 – 0.0157)	0.8 (0.031)
	No. 2 ring	
	4G61 0.35 – 0.50 (0.0138 – 0.0197)	0.8 (0.031)
	4G63, 4G67 0.45 – 0.60 (0.0177 – 0.0236)	0.8 (0.031)
	Oil ring 0.20 – 0.70 (0.0079 – 0.0276)	1.0 (0.039)
Ring-to-ring groove clearance	No. 1 ring 0.03–0.07 (0.0012–0.0028)	0.1 (0.004)
	No. 2 ring 0.02–0.06 (0.0008–0.0024)	0.1 (0.004)
Service size	0.25 (0.010), 0.50 (0.020), 0.75 (0.030), 1.00 (0.039) over size	
Piston pin		
O.D.	21.00 – 21.01 (0.8268 – 0.8272)	
Press-in load N (kg, lbs.)	7,500 – 17,500 (750 – 1,750, 1,653 – 3,858)	
Press-in temperature	Room temperature	
Connecting rod		
Big end center-to-small end center length	149.9–150.0 (5.902–5.906)	
Bend	0.05 (0.0020)	
Twist	0.1 (0.004)	
Big end side clearance	0.10–0.25 (0.0039–0.0098)	
		0.4 (0.016)

mm (in.)

	Standard	Limit
Crankshaft		
End play	0.05 – 0.18 (0.0020–0.0071)	0.25 (0.0098)
Journal O.D.	56.98 – 57.00 (2.2433 – 2.2441)	
Pin O.D.	44.98 – 45.00 (1.7709 – 1.7717)	
Out-of-roundness and taper of journal and pin	Max. 0.01 (0.0004)	
Concentricity of journal	Max. 0.02 (0.0008)	
Oil clearance of journal	0.02 – 0.05 (0.0008 – 0.0020)	0.1 (0.004)
Oil clearance of pin	0.02 – 0.05 (0.0008 – 0.0020)	0.1 (0.004)
Journal		
0.25 U.S.	56.735 – 56.745 (2.2337 – 2.2341)	
0.50 U.S.	56.485 – 56.495 (2.2238 – 2.2242)	
0.75 U.S.	56.235 – 56.245 (2.2140 – 2.2144)	
Pin		
0.25 U.S.	44.735 – 44.745 (1.7612 – 1.7616)	
0.50 U.S.	44.485 – 44.495 (1.7514 – 1.7518)	
0.75 U.S.	44.235 – 44.245 (1.7415 – 1.7419)	
Cylinder block		
Cylinder I.D.		
4G61	82.30 – 82.33 (3.2402 – 3.2413)	
4G63	85.00 – 85.03 (3.3465 – 3.3476)	
4G64	86.50 – 86.53 (3.4055 – 3.4067)	
4G67	81.50 – 81.53 (3.2087 – 3.2098)	
Flatness of gasket surface	0.05 (0.0020)	0.1 (0.004)
Grinding limit		*0.2 (0.008)
* Includes/Combined with cylinder head grinding.		
Overall height		
4G61	274.9 – 275.1 (10.823 – 10.831)	
4G63, 4G67	283.9 – 284.1 (11.177 – 11.185)	
4G64	289.9 – 290.1 (11.413 – 11.421)	
Flywheel		
Runout		0.13 (0.0051)
Oil pump		
Side clearance		
Drive gear	0.08 – 0.14 (0.0031 – 0.0055)	
Driven gear	0.06 – 0.12 (0.0024 – 0.0047)	
Drive belt		
Deflection		
V-ribbed type belt		
New belt	7.5 – 9.0 (0.30 – 0.35)	
Used belt	8.0 (0.32)	
V type belt	7.0 – 10.0 (0.28 – 0.39)	
Tension		
V-ribbed type belt		
New belt	500 – 700 N (50 – 70 kg, 110 – 154 lbs.)	
Used belt	400 N (40 kg, 88 lbs.)	
Oil cooler by-pass valve		
Dimension (L)	34.5 (1.358) – normal temperature	
By-pass hole closing temperature	97 – 103°C (207 – 217°F) or more	

mm (in.)

	Standard	Limit
Thermostat		
Identification mark "82"		
Initial opening temperature	82°C (179°F)	
Fully opened temperature	95°C (203°F)	
Lift	8 (0.32) or more	
Identification mark "88"		
Initial opening temperature	88°C (179°F)	
Fully opened temperature	100°C (212°F)	
Lift	8 (0.32) or more	
Coolant temperature gauge unit		
Resistance	230Ω at 50°C (122°F)	
	104Ω at 70°C (158°F)	
Coolant temperature sensor		
Resistance	5.9kΩ at 0°C (32°F)	
	2.5kΩ at 20°C (68°F)	
	1.1kΩ at 40°C (104°F)	
	0.3kΩ at 80°C (176°F)	

NOTE

O.D.: Outer Diameter
 I.D.: Inner Diameter
 U.S.: Undersize Diameter

TORQUE SPECIFICATIONS

	Nm	Torque kgm	ft.lbs.
Timing belt			
Cooling fan bolt	11	1.1	8
Water pump pulley bolt – Engine without cooling fan	9	0.9	7
Water pump pulley bolt – Engine with cooling fan	11	1.1	8
Crankshaft pulley bolt	25	2.5	18
Crankshaft sprocket bolt	120	12	87
Tensioner bolt – Single camshaft engine	49	4.9	35
Tensioner spacer – Single camshaft engine	49	4.9	35
Tensioner pulley bolt – Double camshaft engine	49	4.9	35
Tensioner arm bolt – Double camshaft engine	22	2.2	16
Auto tensioner bolt – Double camshaft engine	24	2.4	17
Idler pulley bolt – Double camshaft engine	38	3.8	27
Tensioner “B” bolt	19	1.9	14
Oil pump sprocket nut	55	5.5	40
Camshaft sprocket bolt	90	9	65
Right silent shaft sprocket bolt	46	4.6	33
Intake manifold			
Intake manifold bolt and nut	18	1.8	13
Intake manifold bolt (M10) and nut (M10) – Double camshaft engine	36	3.6	26
Intake manifold stay bolt – Single camshaft engine	22	2.2	16
Intake manifold stay bolt – Double camshaft engine	28	2.8	20
Air intake plenum bolt and nut	18	1.8	13
Air intake plenum stay bolt	18	1.8	13
Water outlet fitting bolt	19	1.9	14
Engine coolant temperature gauge unit	11	1.1	8
Engine coolant temperature sensor	30	3	22
Thermostat case nut	18	1.8	13





	Nm	Torque kgm	ft.lbs.
Exhaust manifold and water pump			
Oil level gauge guide bolt			
M8	14	1.4	10
M10	60	6	43
Heat protector bolt			
M6	9	0.9	7
M8 – Engine with fuel injection	14	1.4	10
M8 – Engine with carburettor	30	3	22
Exhaust manifold nut – Single camshaft engine	18	1.8	13
Exhaust manifold nut – Double camshaft engine	28	2.8	20
Air outlet fitting bolt	19	1.9	14
Turbocharger bolt and nut	60	6	43
Exhaust fitting bolt	60	6	43
Water inlet pipe bolt	14	1.4	10
Water pump bolt	24	2.4	17
Water pipe "A" and "B" eye bolt	43	4.3	31
Water pipe "A" bolt	11	1.1	8
Water pipe "B" flare nut	45	4.5	33
Water pipe bolt			
M8	14	1.4	10
M6	11	1.1	8
Oil return pipe bolt	9	0.9	7
Oil pipe			
Cylinder head side	17	1.7	12
Turbocharger side	31	3.1	22
Turbocharger			
west gate actuator bolt	12	1.2	9
Rocker arms and camshaft			
Rocker cover bolt – Single camshaft engine	6	0.6	4
Rocker cover bolt – Double camshaft engine	3	0.3	2.2
Bearing cap bolt – Single camshaft engine			
M8 x 25	24	2.4	17
M8 x 65	20	2	14
Bearing cap bolt – Double camshaft engine	20	2	14
Oil delivery body (valve body assembly)	11	1.1	8
Rocker arms and rocker shafts			
Adjusting screw nut	15	1.5	11
Cylinder head and valves			
Cylinder head bolt	95	9.5	69



	Nm	Torque kgm	ft.lbs.
Front case, silent shaft and oil pan			
Drain plug	40	4	29
Oil pan bolt	7	0.7	5
Oil screen bolt and nut	19	1.9	14
Check valve	33	3.3	24
Oil cooler bolt	43	4.3	31
Oil filter bracket bolt	19	1.9	14
Plug	24	2.4	17
Left silent shaft flange bolt	37	3.7	27
Front case bolt			
M8	24	2.4	17
M10	31	3.1	22
Oil pressure switch	10	1	7
Oil cooler by-pass valve	55	5.5	40
Relief plug	45	4.5	33
Oil pump cover bolt	17	1.7	12
Piston and connecting rod			
Connecting rod cap nut	52	5.2	38
Crankshaft, flywheel and drive plate			
Flywheel bolt	135	13.5	98
Drive plate bolt	135	13.5	98
Oil seal case bolt	11	1.1	8
Bearing cap bolt – Single camshaft engine	53	5.3	38
Bearing cap bolt – Double camshaft engine	68	6.8	49
Cylinder block			
Left and right engine surppout bracket bolt	45	4.5	33
Front roll stopper bracket bolt	65	6.5	47
Rear roll stopper bracket bolt	120	12	87
Front engine support bracket bolt	60	6	43
Left engine support bracket bolt	36	3.6	26
Exhaust pipe support bracket bolt	36	3.6	26

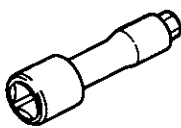
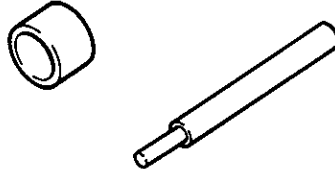
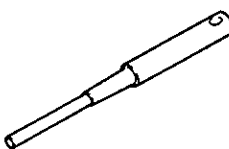

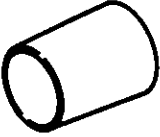
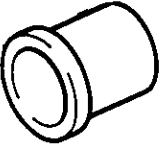

SEALANT

	Specified sealant	Quantity
Rocker cover	3M ATD Part No. 8660 or equivalent	As required
Semi-circular packing	3M ATD Part No. 8660 or equivalent	As required
Oil pan gasket	MITSUBISHI GENUINE PART	As required
	MD997110 or equivalent	
Engine coolant temperature gauge unit	3M ATD Part No. 8660 or equivalent	As required
Engine coolant temperature sensor	3M Nut Locking Part No. 4171	As required
	or equivalent	
Oil pressure switch	3M ATD Part No. 8660 or equivalent	As required

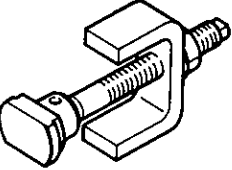
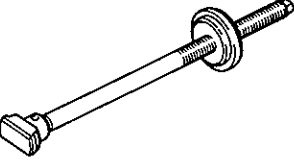
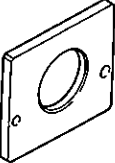
2. SPECIAL TOOLS

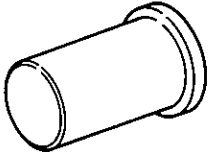
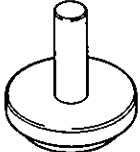
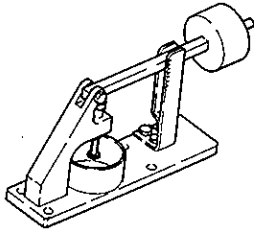
Tool	Number	Name	Use
	MB990685	Torque wrench	Adjustment of timing belt tension (Double camshaft engine)
	MD998051	Cylinder head bolt wrench	Removal and installation of cylinder head bolt
	MD998115	Valve guide installer	Removal and installation of valve guide (Single camshaft engine)
	MD998148 MD998615	Valve seat cutter pilot	Correction of valve seat
	MD998172 MD998175 (intake) MD998171 MD998173 (exhaust)	Valve seat cutter 30°	Correction of valve seat
	MD998157 MD998159 (intake) MD998156 MD998158 (exhaust)	Valve seat cutter 45°	Correction of valve seat
	MD998165 MD998614 (common to intake and exhaust)	Valve seat cutter 65°	Correction of valve seat

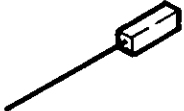
Tool	Number	Name	Use
	MD998162	Plug wrench	Removal and installation of front case cap plug
	MD998285	Crankshaft front oil seal guide	Guide for installation of crankshaft front oil seal (Use with MD998375)
	MD998306	Camshaft oil seal installer	Installation of camshaft oil seal (Use with MD998307)
	MD998307	Camshaft oil seal guide	Guide for installing camshaft oil seal (Use with MD998306)
	MD998371	Silent shaft bearing puller	Removal of silent shaft front bearing
	MD998372	Silent shaft bearing puller	Removal of silent shaft rear bearing
	MD998374	Silent shaft bearing installer stopper	Guide stopper for use in removal and installation of silent shaft rear bearing

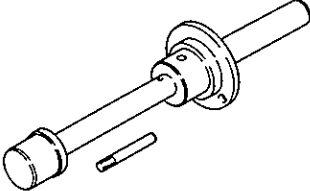
Tool	Number	Name	Use
	MD998375	Crankshaft front oil seal installer	Installation of crankshaft front oil seal
	MD998376	Crankshaft rear oil seal installer	Installation of crankshaft rear oil seal
	MD998440	Leak-down tester	Leak-down test of lash adjuster
	MD998441	Lash adjuster retainer	Air bleeding of lash adjuster (Single camshaft engine)
	MD998442	Air bleed wire	Air bleeding of lash adjuster
	MD998443	Lash adjuster holder	Retainer for holding lash adjuster in rocker arm at time of removal and installation of rocker arm and rocker shaft assembly (Single camshaft engine)
	MD998705	Silent shaft bearing installer	Installation of silent shaft front and rear bearings

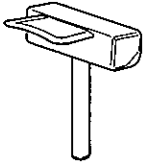
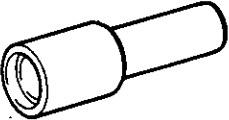
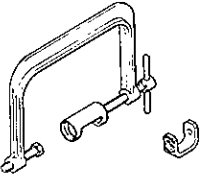
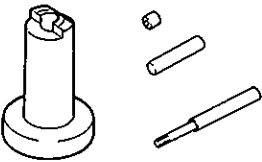
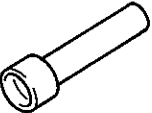
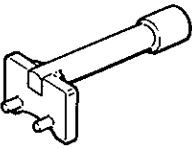
Tool	Number	Name	Use
	MD998727	Oil pan remover	Removal of the oil pan
	MD998729	Valve stem seal installer	Installation of valve stem seal (Single camshaft engine)
	MD998735 (including MD998743, MD998744, MD998745)	Valve spring compressor	Compression of valve spring (Double camshaft engine)
	MD998736 (including MD998751)	Piston pin setting tool	Removal and installation of piston pin
	MD998737	Valve stem seal installer	Installation of valve stem seal (Double camshaft engine)
	MD998752	Socket wrench	Adjustment of timing belt tension (Double camshaft engine)

3. DRIVE BELT AND TIMING BELT (SINGLE CAMSHAFT ENGINE) REMOVAL AND INSTALLATION

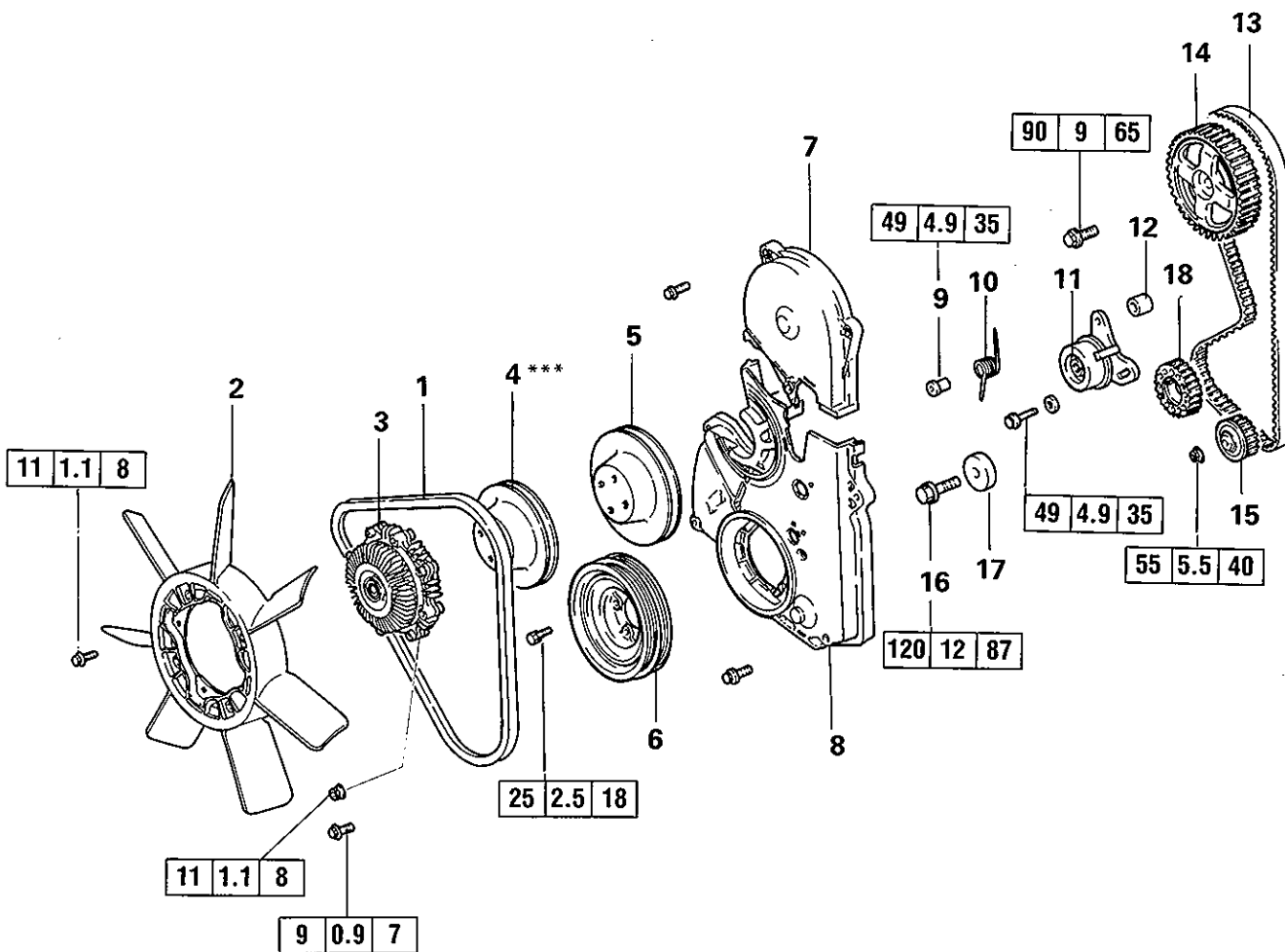

Removal steps

1. Drive belt
2. Cooling fan
3. Fan clutch
4. Water pump pulley***
5. Water pump pulley
6. Crankshaft pulley
7. Timing belt front upper cover
8. Timing belt front lower cover
9. Tensioner spacer
10. Tensioner spring
11. Tensioner
12. Spacer
13. Timing belt
14. Camshaft sprocket
15. Oil pump sprocket
16. Crankshaft sprocket bolt

17. Special washer
18. Crankshaft sprocket
19. Flange
20. Spacer*
21. Tensioner "B"***
22. Timing belt "B"***
23. Right silent shaft sprocket**
24. Spacer**
25. Crankshaft sprocket "B"***

NOTE

- * : Engine without silent shaft
- ** : Engine with silent shaft
- *** : Engine with power steering
- **** : Engine with cooling fan
- ***** : Engine without cooling fan

11A-3-2 ENGINE – Drive Belt and Timing Belt (Single Camshaft Engine)

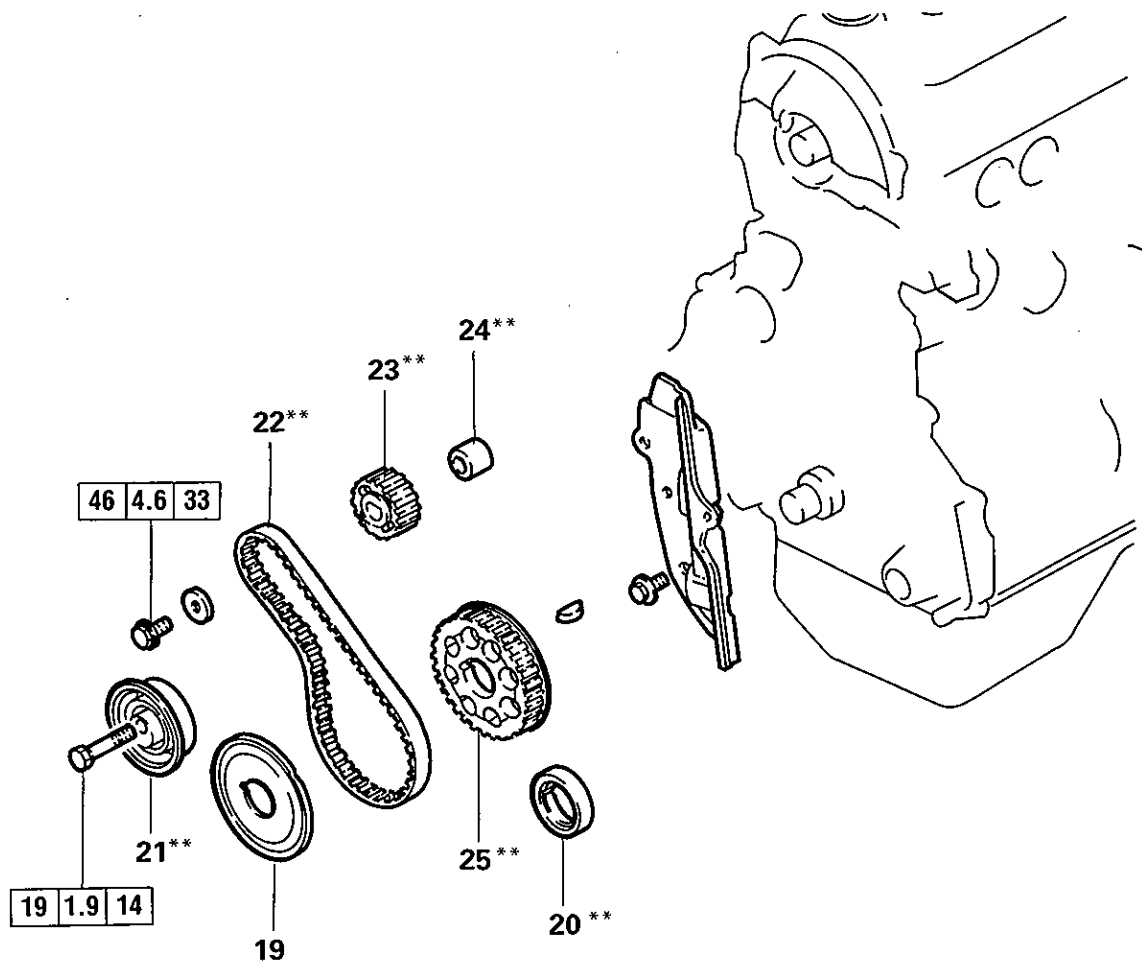

Installation steps

- 25. Crankshaft sprocket "B" **
- ◆A◆ 24. Spacer **
- 23. Right silent shaft sprocket **
- 21. Tensioner "B" **
- ◆B◆ 22. Timing belt "B" **
- 20. Spacer *
- ◆C◆ 19. Flange
- 18. Crankshaft sprocket
- 17. Special washer
- 16. Crankshaft sprocket bolt
- ◆D◆ 15. Oil pump sprocket
- 14. Camshaft sprocket

- 12. Spacer
- ◆E◆ 11. Tensioner
- 10. Tensioner spring
- 9. Tensioner spacer
- ◆F◆ 13. Timing belt
- 8. Timing belt front lower cover
- 7. Timing belt front upper cover
- 6. Crankshaft pulley
- 5. Water pump pulley
- 4. Water pump pulley
- 3. Fan clutch
- 2. Cooling fan
- ◆G◆ 1. Drive belt

6EN0474

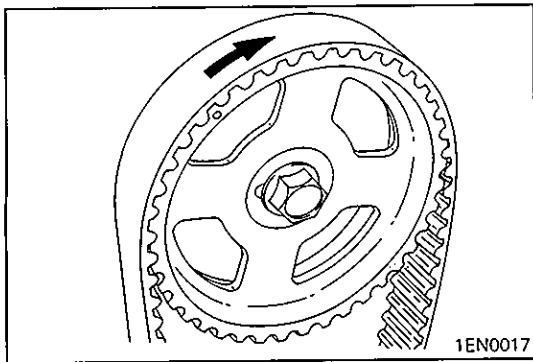

SERVICE POINTS OF REMOVAL

◊A◊ REMOVAL OF TIMING BELT

- (1) Make a mark on the back of the timing belt indicating the direction of rotation so it may be reassembled in the same direction if it is to be reused.

NOTE

- (1) Water or oil on the belt shorten its life drastically, so the removed timing belt, sprocket, and tensioner must be free from oil and water. These parts should not be washed. Replace parts if seriously contaminated.
- (2) If there is oil or water on each part check front case oil seals, camshaft oil seal and water pump for leaks.

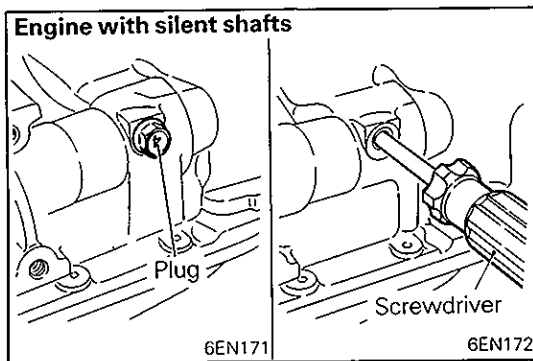

◊B◊ REMOVAL OF OIL PUMP SPROCKET (ENGINE WITH SILENT SHAFTS)

- (1) Remove the plug on the left side of cylinder block.
- (2) Insert a Phillips screwdriver [shank diameter 8 mm (0.31 in.)] to block the left silent shaft.
- (3) Remove the nut.
- (4) Remove the oil pump sprocket.

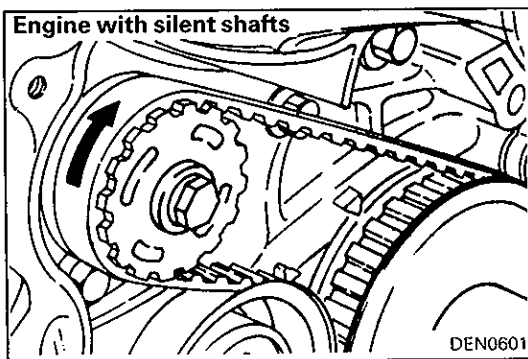

◊C◊ REMOVAL OF TIMING BELT "B" (ENGINE WITH SILENT SHAFTS)

- (1) Make a mark on the back of the timing belt indicating the direction of rotation so it may be reassembled in the same direction if it is to be reused.

NOTE

- (1) Water or oil on the belt shorten its life drastically, so the removed timing belt, sprocket, and tensioner must be free from oil and water. These parts should not be washed. Replace parts if seriously contaminated.
- (2) If there is oil or water on each part check front case oil seals, camshaft oil seal and water pump for leaks.

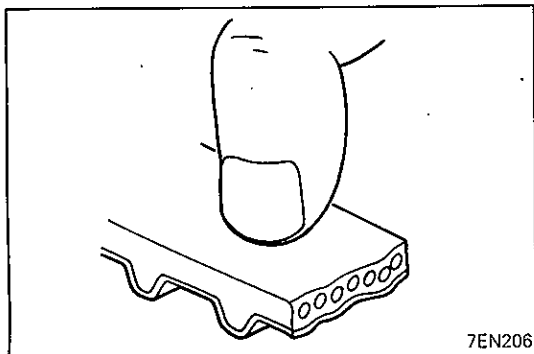

INSPECTION

TIMING BELTS

The timing belts must be checked closely. Should the following defects be evident, replace the belt with a new one.

- (1) Hardened back surface rubber
Glossy, non-elastic, and so hard that no mark is produced even when scratched by fingernails.

11A-3-4 ENGINE – Drive Belt and Timing Belt (Single Camshaft Engine)

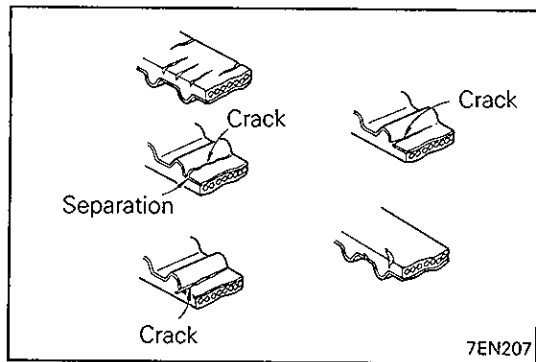

- (2) Cracked back surface rubber
- (3) Cracked or separated canvas
- (4) Cracked tooth bottom
- (5) Cracked side

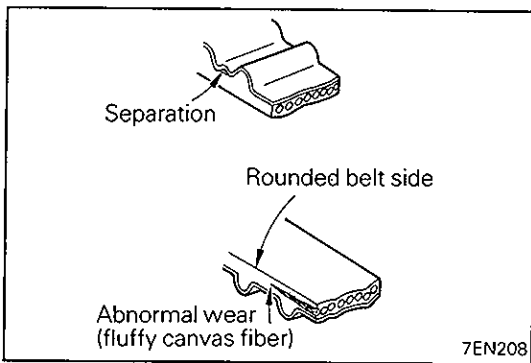

- (6) Abnormal wear on side

NOTE

Normal belt should have clear-cut sides as if cut by a sharp knife.

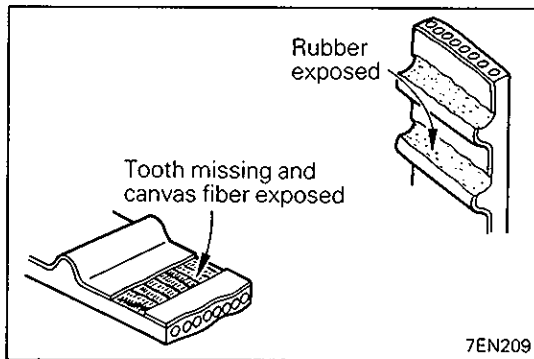

- (7) Abnormal wear in teeth

Initial stage:

Canvas on load side tooth flank worn (Fluffy canvas fibers, rubber gone and color changed to white, and unclear canvas texture)

Final stage:

Canvas on load side tooth flank worn down and rubber exposed (tooth width reduced)

- (8) Missing tooth

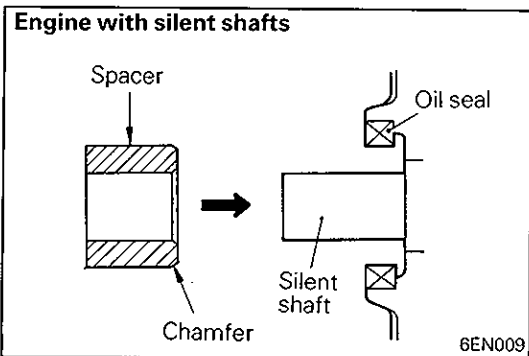

SERVICE POINTS OF INSTALLATION

▶▶ INSTALLATION OF SPACER (ENGINE WITH SILENT SHAFTS)

- (1) Install the spacer with the chamfered end toward the oil seal.

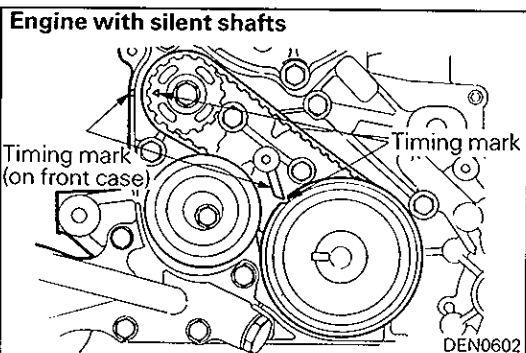

▶▶ INSTALLATION OF TIMING BELT "B" (ENGINE WITH SILENT SHAFTS)

- (1) Align timing marks on the crankshaft sprocket "B" and silent shaft sprocket with the marks on the front case respectively.
- (2) Install the timing belt "B" on the crankshaft sprocket "B" and silent shaft sprocket. There should be no slack on the tension side.

260

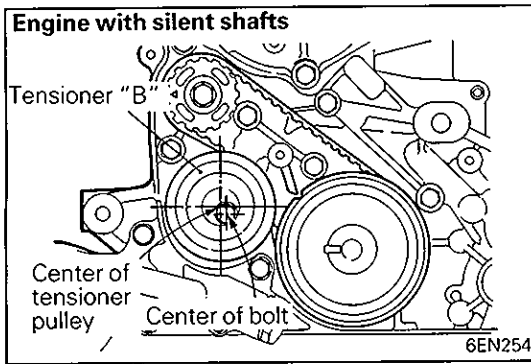

- (3) Make sure that the relationship between the tensioner pulley center and the bolt center is as shown in the illustration.

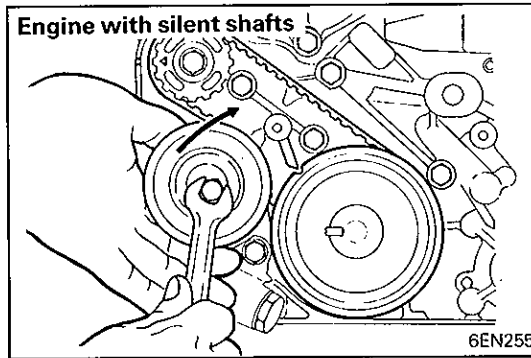

- (4) Move the tensioner "B" in the direction of arrow while lifting with a finger to give a sufficient tension to the tension side of timing belt. In this condition, tighten bolt to secure tensioner "B". When bolt is tightened, use care to prevent shaft from turning together. If shaft is turned together, belt will be overtensioned.

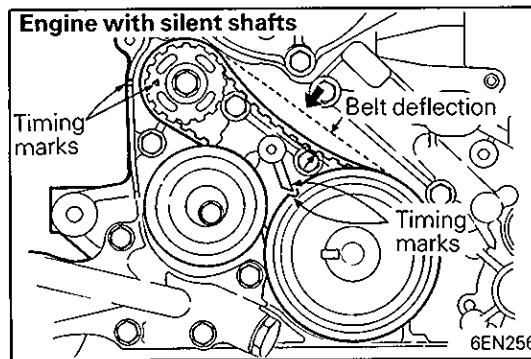

- (5) Check to ensure that timing marks on sprockets and front case are in alignment.

- (6) Press with index finger the center of span on tension side of timing belt "B". The bolt must deflect 5 – 7 mm (0.20 – 0.28 in.).

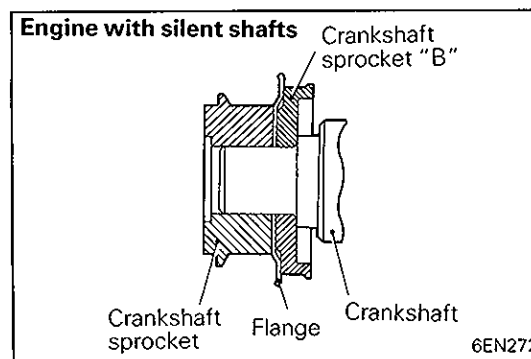

INSTALLATION OF FLANGE

- (1) Pay special attention to direction of flange. If it is installed in wrong direction, a broken timing belt could result.

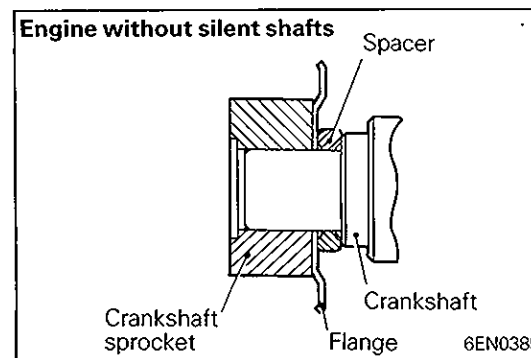

11A-3-6 ENGINE – Drive Belt and Timing Belt (Single Camshaft Engine)

Engine with silent shafts

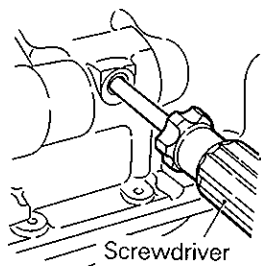

6EN172

◆D◆ INSTALLATION OF OIL PUMP SPROCKET (ENGINE WITH SILENT SHAFTS)

- (1) Insert a Phillips screwdriver [shank diameter 8 mm (0.31 in.) shaft] through the plug hole on the left side of cylinder block to block the left silent shaft.
- (2) Install the oil pump sprocket.
- (3) Tighten the nuts to the specified torque.

◆E◆ INSTALLATION OF TENSIONER

- (1) Hook the tensioner spring ends to the water pump body projection and tensioner bracket.
- (2) Move tensioner fully toward water pump and tighten the bolt and tensioner spacer.

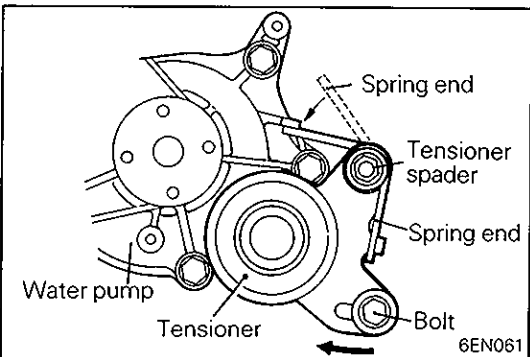

6EN061

◆F◆ INSTALLATION OF TIMING BELT

- (1) Align the timing marks on camshaft sprocket and crankshaft sprocket with their mating marks.
- (2) Align the timing mark on oil pump sprocket with its mating mark. (Engine with silent shafts)

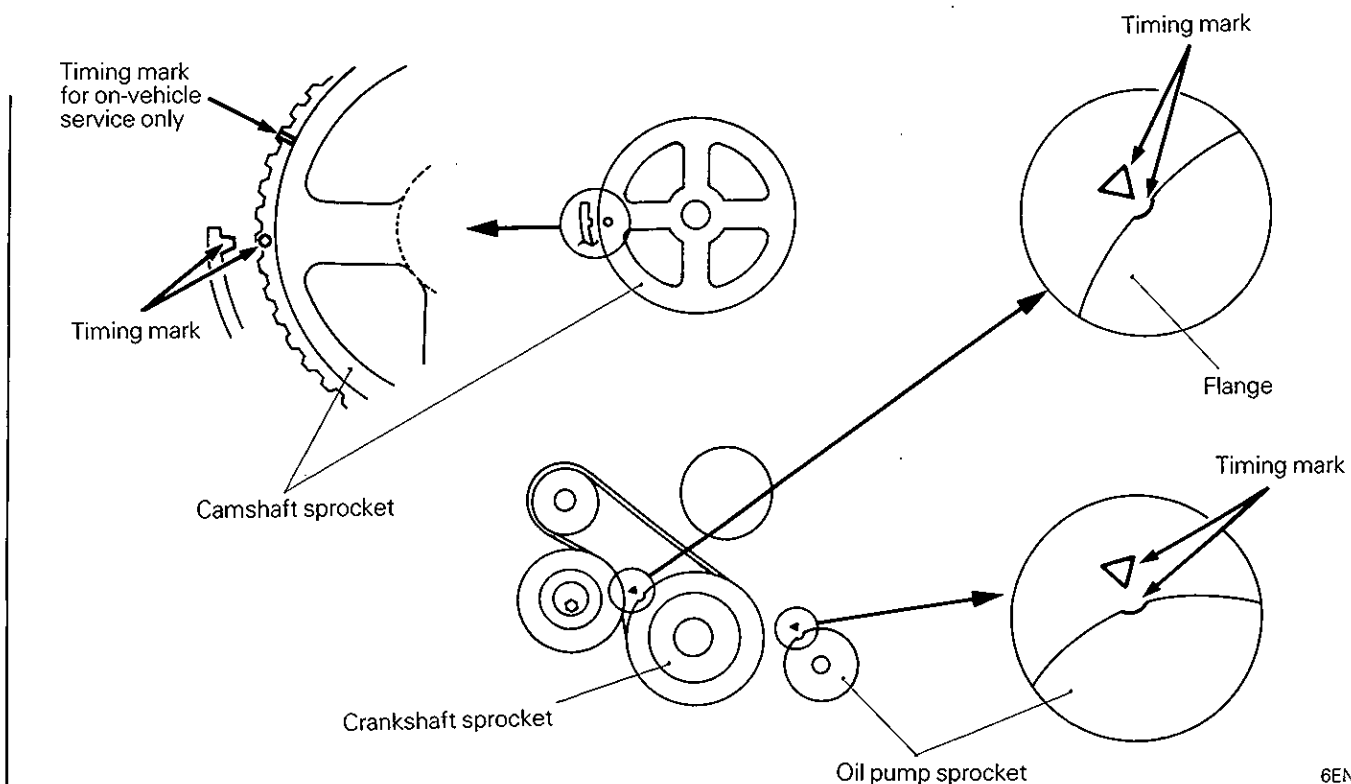

6EN0475

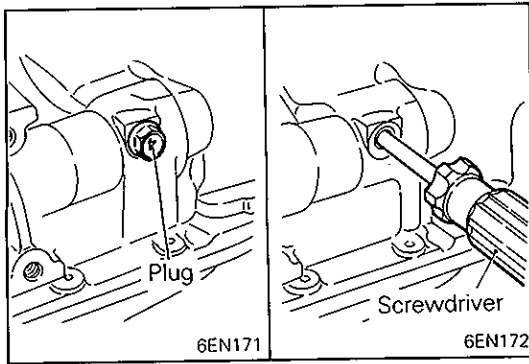

- (3) Remove the plug on cylinder block and insert a Phillips screwdriver [shank diameter 8 mm (0.31 in.)] through the hole (Engine with silent shafts).
If it can be inserted as deep as 60 mm (2.4 in.) or more, the timing marks are correctly aligned. If the inserted depth is only 20 – 25 mm (0.8 – 1.0 in.), turn the oil pump sprocket one turn and realign timing marks. Then check to ensure that the screwdriver can be inserted 60 mm (2.4 in.) or more. Keep the screwdriver inserted until installation of timing belt is finished.
- (4) Install the timing belt on the crankshaft sprocket, oil pump sprocket and camshaft sprocket in that order. There should be no slack on the tension side.

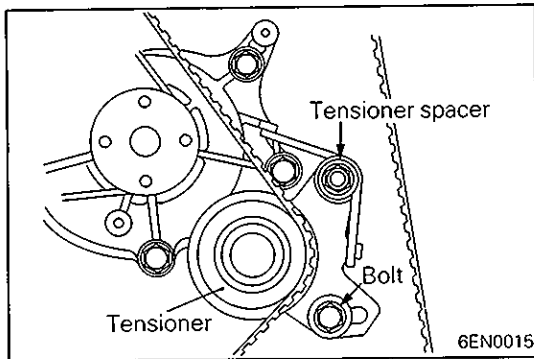

- (5) Loosen the tensioner mounting bolt and tensioner spacer.

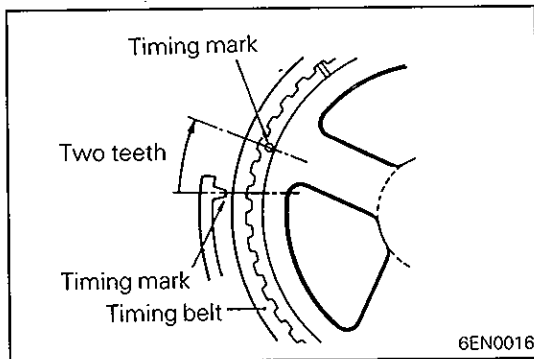

- (6) Turn the crankshaft clockwise by two teeth of camshaft sprocket (or crankshaft sprocket).

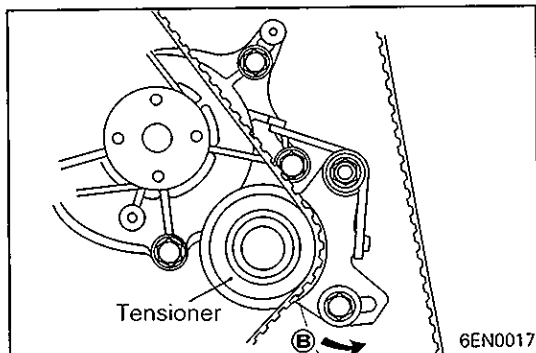

- (7) Apply force to the tensioner in the direction shown by arrow **B** to make the belt engage completely with each sprocket.

11A-3-8 ENGINE – Drive Belt and Timing Belt (Single Camshaft Engine)

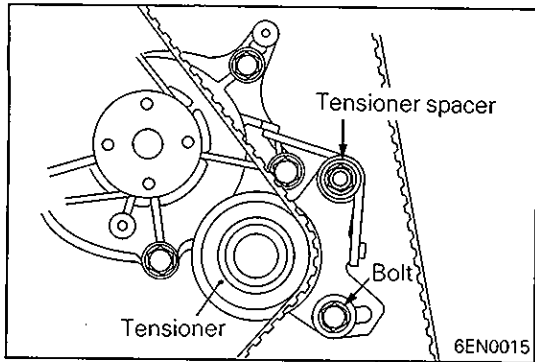

- (8) Tighten the tensioner attaching bolt, then tighten the tensioner spacer.

Caution

- If the tensioner spacer is tightened first, tensioner turns as the tensioner spacer is tightened, resulting in an excessive belt tension.

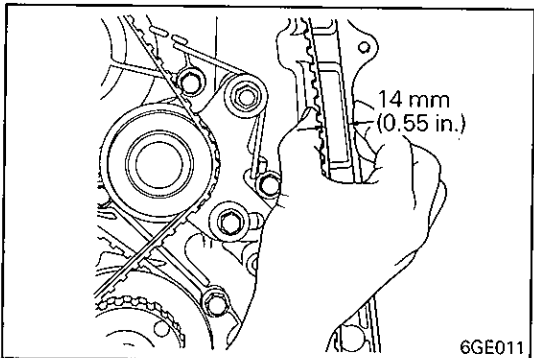

- (9) Hold the center of the tension side span of the timing belt (between the camshaft and oil pump sprockets) between your thumb and index finger as shown. Then, make sure that the clearance between the belt back surface and cover is standard value.

Standard value: 14 mm (0.55 in.)

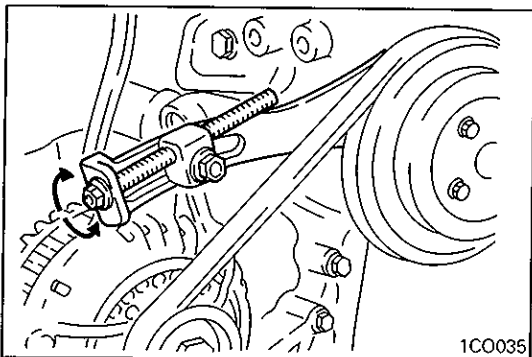

◆G◆ ADJUSTMENT OF DRIVE BELT TENSION ADJUSTER TYPE

- (1) Adjust belt deflection to standard value. Turn adjusting bolt clockwise to increase the belt tension and turn adjusting bolt counterclockwise to decrease the belt tension.

Standard value:

V-ribbed type belt

New belt 7.5 – 9.0 mm (0.30 – 0.35 in.)

Used belt 8.0 mm (0.32 in.)

V-type belt 7.0 – 10.0 mm (0.28 – 0.39 in.)

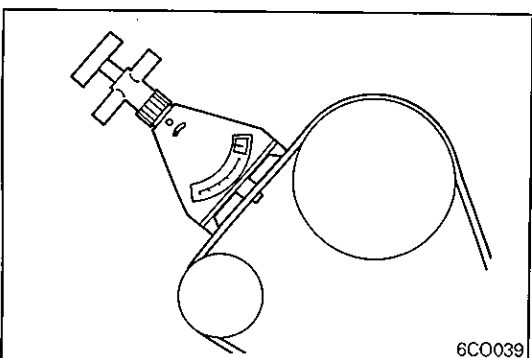
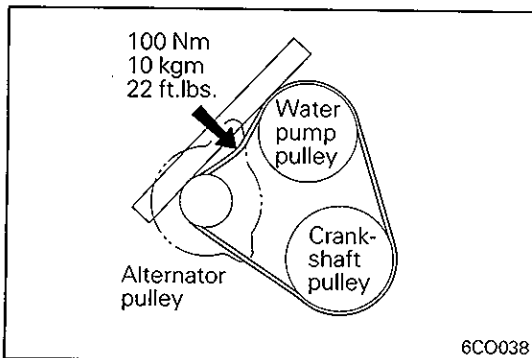

When using the tension gauge, turn adjusting bolt to adjust tension to standard value. (V-ribbed type belt only)

Standard value:

New belt 500 – 700 N (50 – 70 kg, 110 – 154 lbs.)

Used belt 400 N (40 kg, 88 lbs.)

- (2) Tighten lock bolt to the specified torque.
(3) Tighten nut for pivot bolt to the specified torque.

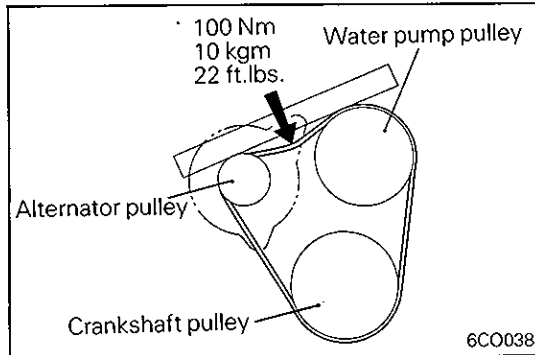
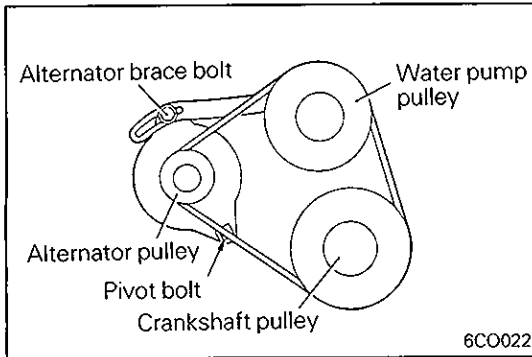

BRACE BOLT TYPE

(1) Move alternator to adjust belt deflection to standard value.

Standard value:

V-ribbed type belt

New belt 7.5 – 9.0 mm (0.30 – 0.35 in.)

Used belt 8.0 mm (0.32 in.)

V-type belt 7.0 – 10.0 mm (0.28 – 0.39 in.)

When using tension gauge, turn adjusting bolt to adjust tension to standard value. (V-ribbed belt only)

Standard value:

New belt 500 – 700 N (50 – 70 kg, 110 – 154 lbs.)

Used belt 400 N (40 kg, 88 lbs.)

(2) Tighten brace bolt to the specified torque.

(3) Tighten nut for pivot bolt to the specified torque.

NOTES

4. DRIVE BELT AND TIMING BELT (DOUBLE CAMSHAFT ENGINE) REMOVAL AND INSTALLATION

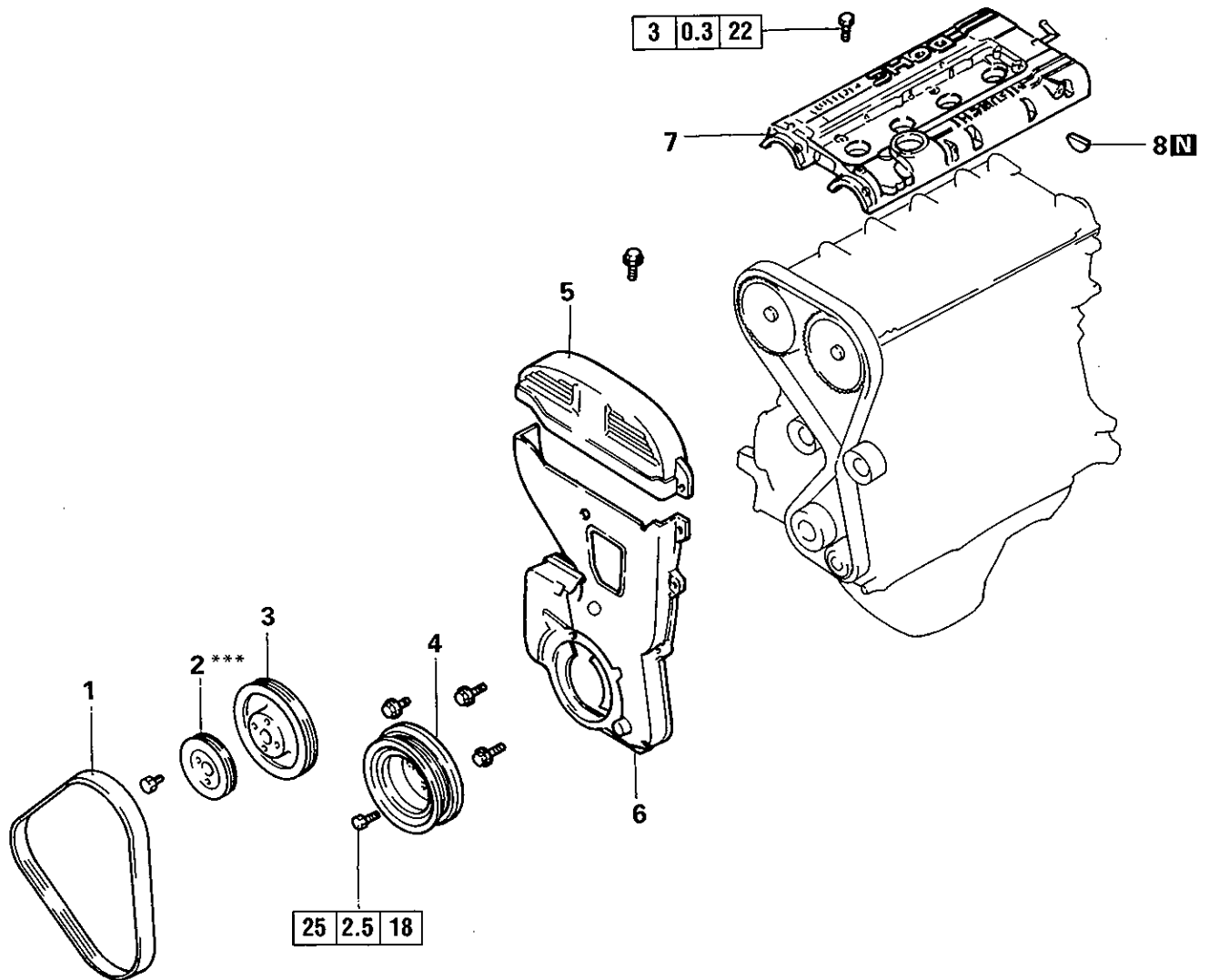

Removal steps

- | | | |
|-----|----------------------------------|---|
| | 1. Drive belt | 17. Crankshaft sprocket bolt |
| | 2. Water pump pulley*** | 18. Special washer |
| | 3. Water pump pulley | 19. Crankshaft sprocket |
| | 4. Crankshaft pulley | 20. Flange |
| | 5. Timing belt front upper cover | 21. Spacer* |
| | 6. Timing belt front lower cover | 22. Tensioner "B"*** |
| | 7. Rocker cover | 23. Timing belt "B"*** |
| | 8. Semi-circular packing | 24. Silent shaft sprocket** |
| | 9. Rubber plug | 25. Spacer** |
| | 10. Auto tensioner | 26. Crankshaft sprocket "B"*** |
| ◊A◊ | 11. Timing belt | 27. Timing belt rear right cover |
| | 12. Tensioner pulley | 28. Timing belt rear left cover (upper) |
| | 13. Tensioner arm | |
| ◊B◊ | 14. Idler pulley | |
| ◊C◊ | 15. Camshaft sprocket | |
| | 16. Oil pump sprocket** | |

NOTE:

Refer to 13 Front Case, Silent Shaft and Oil Pan for removal of the oil pump sprocket of 4G61.

NOTE

- * : Engine without silent shafts
 ** : Engine with silent shafts
 *** : Power steering pump drive

11A-4-2 ENGINE – Drive Belt and Timing Belt (Double Camshaft Engine)

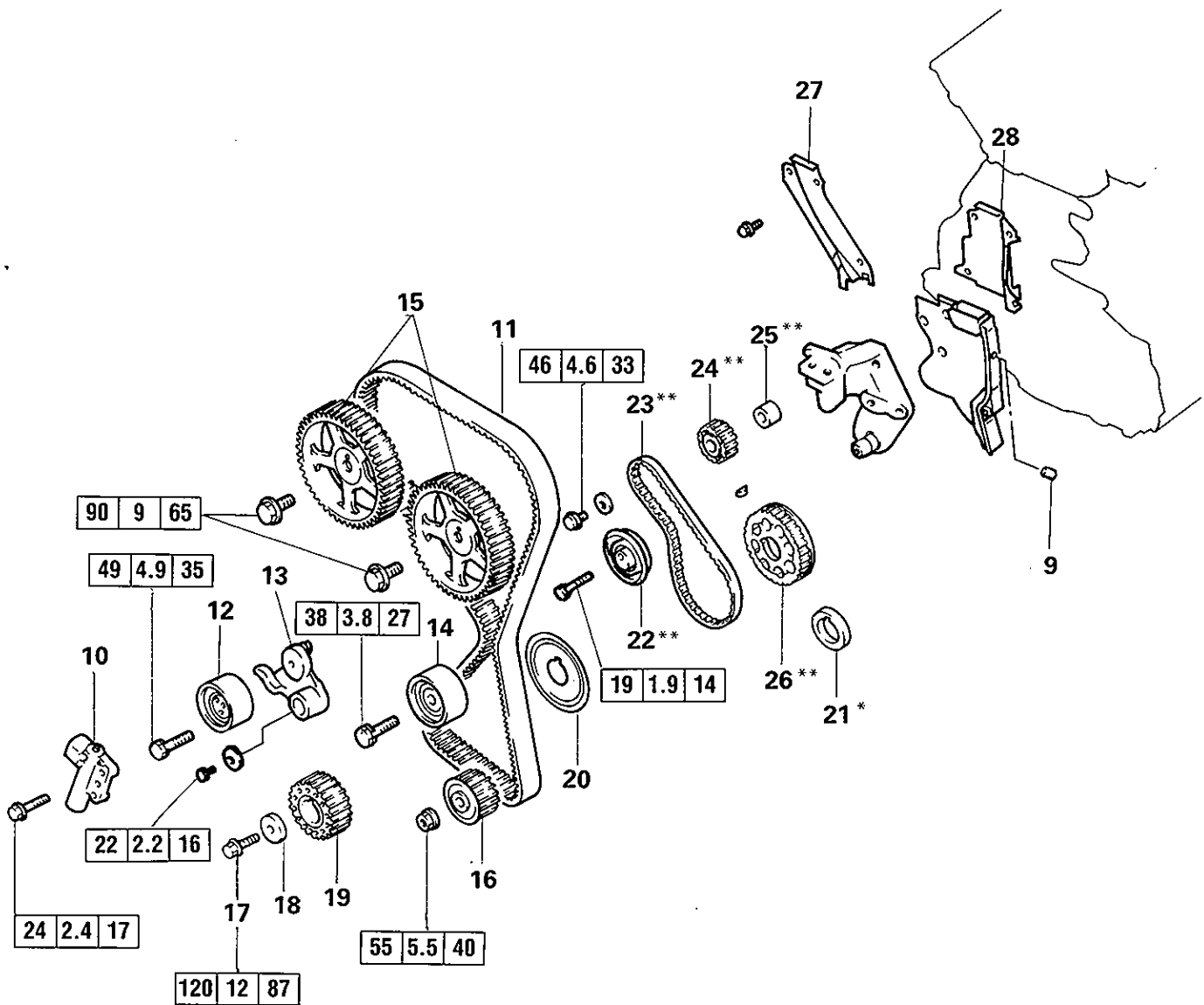

Installation steps

- 28. Timing belt rear left cover
- 27. Timing belt rear right cover
- 26. Crankshaft sprocket "B"***
- ▶A 25. Spacer**
- ▶B 24. Silent shaft sprocket**
- 22. Tensioner "B"***
- 23. Timing belt "B"***
- 21. Spacer*
- ▶C 20. Flange
- 19. Crankshaft sprocket
- 18. Special washer
- 17. Crankshaft sprocket bolt
- ▶D 16. Oil pump sprocket
- NOTE:
Refer to 13 Front Case, Silent Shaft and Oil Pan for the installation of the oil pump sprocket of 4G61.
- ▶E 15. Camshaft sprocket
- 14. Idler pulley
- ▶F 10. Auto tensioner
- 13. Tensioner arm
- ▶G 12. Tensioner pulley
- ▶H 11. Timing belt
- 9. Rubber plug
- ▶I 8. Semi-circular packing
- ▶J 7. Rocker cover
- 6. Timing belt front lower cover
- 5. Timing belt front upper cover
- 4. Crankshaft pulley
- 3. Water pump pulley
- 2. Water pump pulley***
- ▶K 1. Drive belt

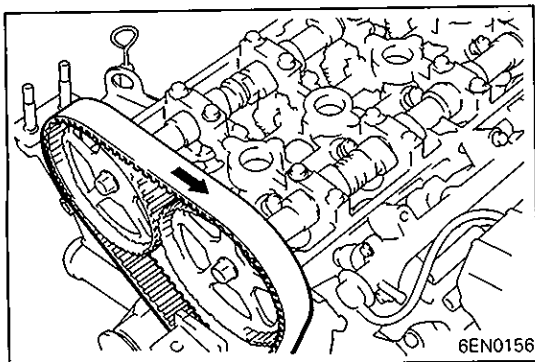

SERVICE POINTS OF REMOVAL

◊A◊ REMOVAL OF TIMING BELT

- (1) Make a mark on the back of the timing belt indicating the direction of rotation so it may be reassembled in the same direction if it is to be reused.

NOTE:

- (1) Water or oil on the belt shorten its life drastically, so the removed timing belt, sprocket, and tensioner must be free from oil and water. These parts should not be washed. Replace parts if seriously contaminated.
- (2) If there is oil or water on each part, check the front case oil seals, camshaft oil seal and water pump for leaks.

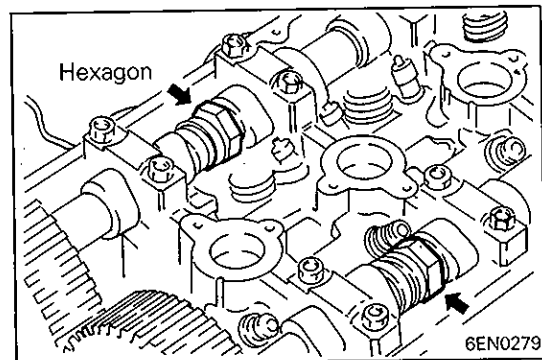

◊B◊ REMOVAL OF CAMSHAFT SPROCKETS

- (1) Using a wrench, hold the camshaft at its hexagon (between the No. 2 and No. 3 journals) and remove the camshaft sprocket bolt.

Caution

- **Locking the camshaft sprocket with a tool damages the sprocket.**

- (2) Remove the camshaft sprockets.

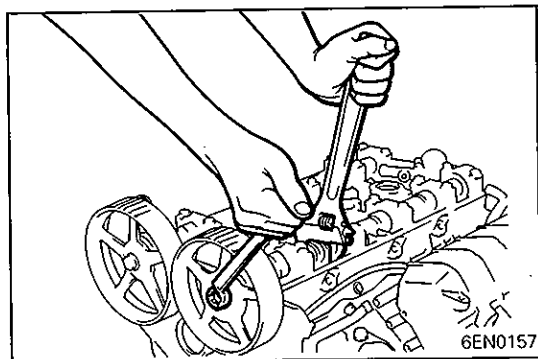

◊C◊ REMOVAL OF OIL PUMP SPROCKET (ENGINE WITH SILENT SHAFTS)

Refer to "◊B◊ REMOVAL OF OIL PUMP SPROCKET" on page 11A-3-3.

◊D◊ REMOVAL OF TIMING BELT "B" (ENGINE WITH SILENT SHAFTS)

Refer to "◊C◊ REMOVAL OF TIMING BELT B" on page 11A-3-3.

INSPECTION

TIMING BELTS

Refer to "INSPECTION" on page 11A-3-3.

11A-4-4 ENGINE – Drive Belt and Timing Belt (Double Camshaft Engine)

AUTO TENSIONER

- (1) Check the auto tensioner for possible leaks and replace as necessary.
- (2) Check the rod end for wear or damage and replace as necessary.

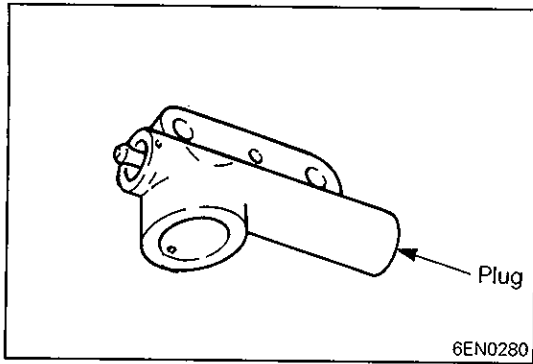

- (3) Measure the rod protrusion. If it is out of specification, replace the auto tensioner.

Standard value: 12 mm (0.47 in.)

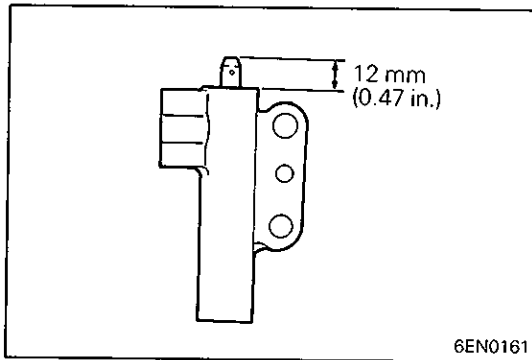

- (4) Clamp the auto tensioner in a vise with soft jaws.

Caution

- The plug at the bottom of the auto tensioner protrudes. Insert a plain washer as illustrated to prevent the plug from being in direct contact with the vise.

- (5) Turning the vise handle, push in the auto tensioner rod. If the rod can be easily retracted, replace the auto tensioner. You should feel a fair amount of resistance when pushing the rod in.

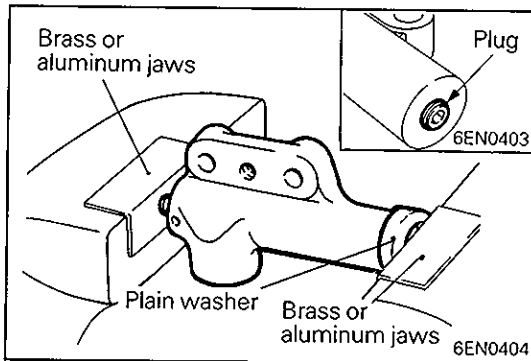

SERVICE POINTS OF INSTALLATION

▶◀ INSTALLATION OF SPACER (ENGINE WITH SILENT SHAFTS)

Refer to "▶◀ INSTALLATION OF SPACER" on page 11A-3-4

▶◀ INSTALLATION OF TIMING BELT "B" (ENGINE WITH SILENT SHAFTS)

Refer to Page 11A-3-4, noting that the timing mark locations differ from those on the single camshaft engine.

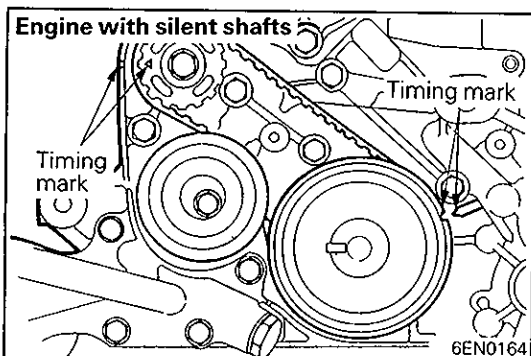

▶C▶ INSTALLATION OF FLANGE

Refer to "▶C▶ INSTALLATION OF FLANGE" on page 11A-3-5.

▶D▶ INSTALLATION OF OIL PUMP SPROCKET (ENGINE WITH SILENT SHAFTS)

Refer to "▶D▶ INSTALLATION OF OIL PUMP SPROCKET" on page 11A-3-6.

▶E▶ INSTALLATION OF CAMSHAFT SPROCKETS

- (1) Using a wrench, hold the camshaft at its hexagon (between the No. 2 and No. 3 journals) and tighten the bolt to specification.

Caution

- **Locking the camshaft sprocket with a tool damages the sprocket.**

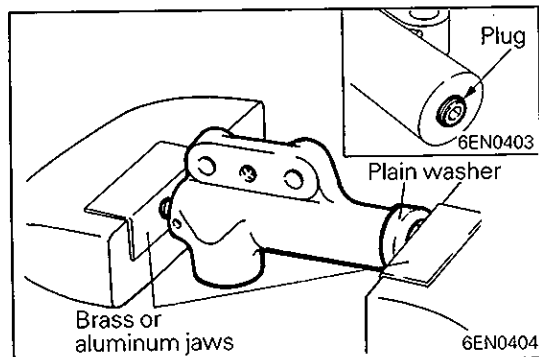
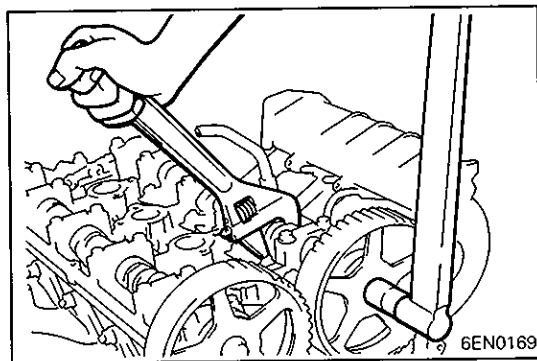
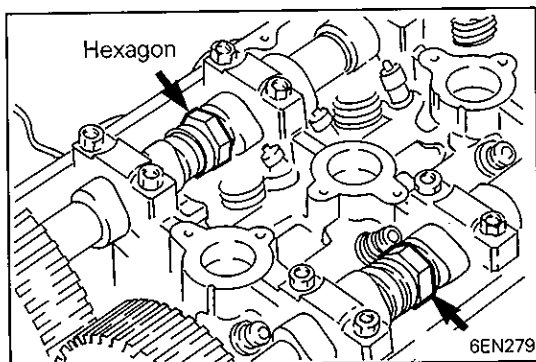

▶F▶ INSTALLATION OF AUTO TENSIONER

- (1) If the auto tensioner rod is in its fully extended position, reset it as follows.
- (2) Clamp the auto-tensioner in the vise with soft jaws.

Caution

- **The plug at the bottom of the auto tensioner protrudes. Insert a plain washer as illustrated to prevent the plug from being in direct contact with the vise.**

- (3) Push in the rod little by little with the vise until the set hole (A) in the rod is aligned with the hole (B) in the cylinder.

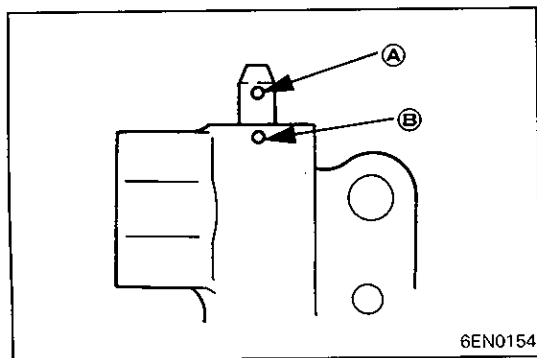

11A-4-6 ENGINE – Drive Belt and Timing Belt (Double Camshaft Engine)

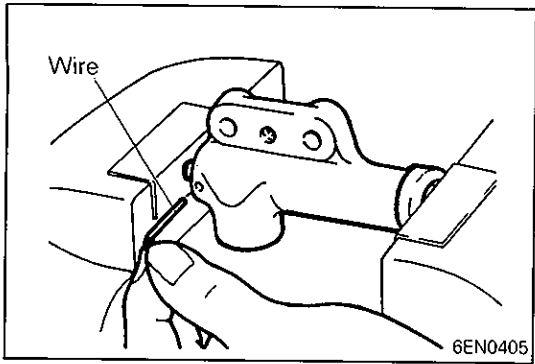

- (4) Insert a wire [1.4 mm (0.055 in.) in diameter] into the set holes.
- (5) Unclamp the auto tensioner from the vise.

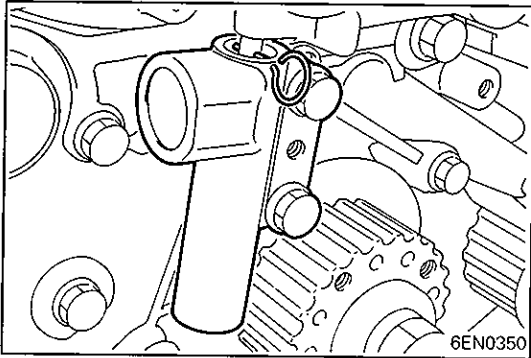

- (6) Install the auto tensioner to front case and tighten to specified torque.

Caution

- Leave the wire installed in the auto tensioner.

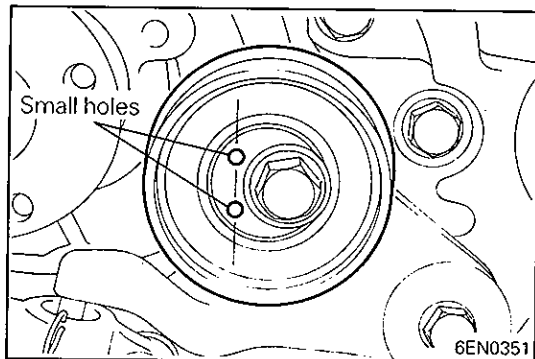

▶G▶ INSTALLATION OF TENSIONER PULLEY

- (1) Install the tensioner pulley in such direction that its two small holes are arranged vertically.

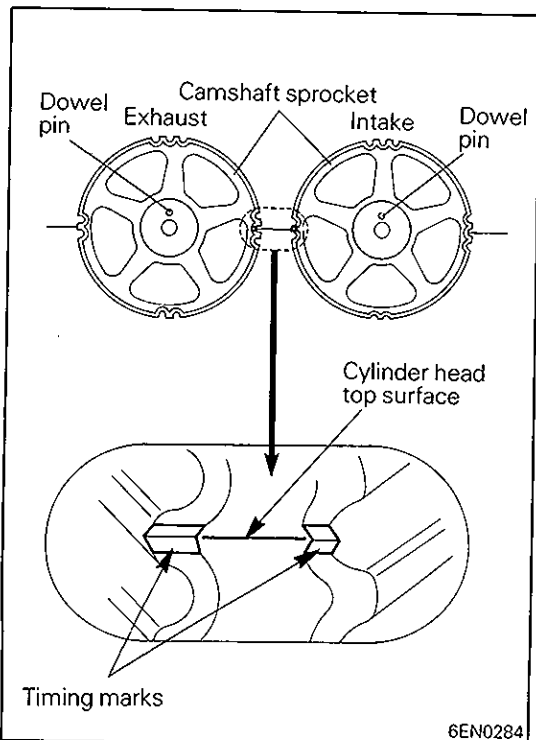

▶H▶ INSTALLATION OF TIMING BELT

- (1) Turn the two sprockets so that their dowel pins are located on top. Then, align the timing marks facing each other with the top surface of the cylinder head. When you let go of the exhaust camshaft sprocket, it will rotate one tooth in the counterclockwise direction. This should be taken into account when installing the timing belt on the sprockets.

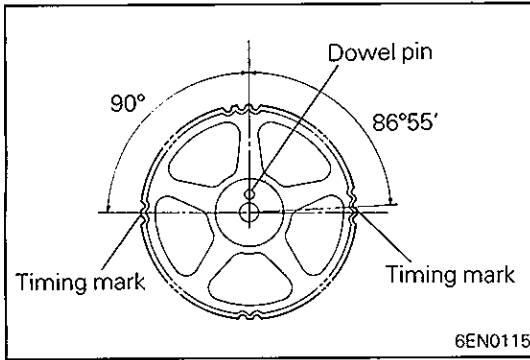

NOTE

The same camshaft sprocket is used for the intake and exhaust camshafts and is provided with two timing marks. When the sprocket is mounted on the exhaust camshaft, use the timing mark on the right with the dowel pin hole on top. For the intake camshaft sprocket, use the one on the left with the dowel pin hole on top.

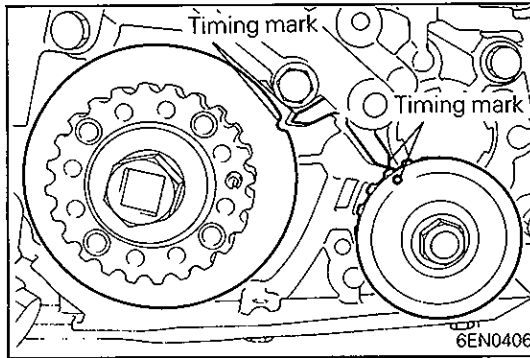

- (2) Align the crankshaft sprocket timing mark.
- (3) Align the oil pump sprocket timing mark (Engine with silent shafts).

NOTE

The timing mark on the oil pump sprocket was changed from ● to ▲ from May, 1988. The sprocket marked with ▲ is tapered.

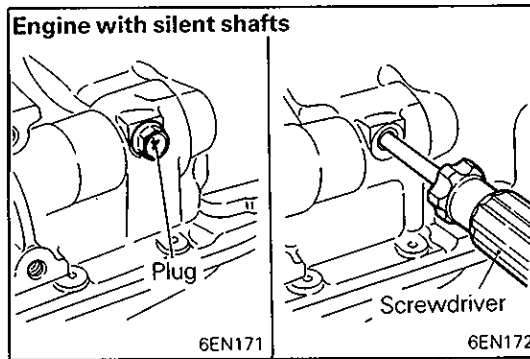

- (4) Insert a Phillips screwdriver [shank diameter 8 mm (0.31 in.)] through the hole (Engine with silent shafts). If it can be inserted as deep as 60 mm (2.4 in.) or more, the timing marks are correctly aligned. If the inserted depth is only 20 – 25 mm (0.8 – 1.0 in.), turn the oil pump sprocket one turn and realign timing marks. Then check to ensure that the screwdriver can be inserted 60 mm (2.4 in.) or more. Keep the screwdriver inserted until the installation of the timing belt is finished.

NOTE

Step (4) is performed to ensure that the oil pump sprocket is correctly positioned with reference to the silent shafts.

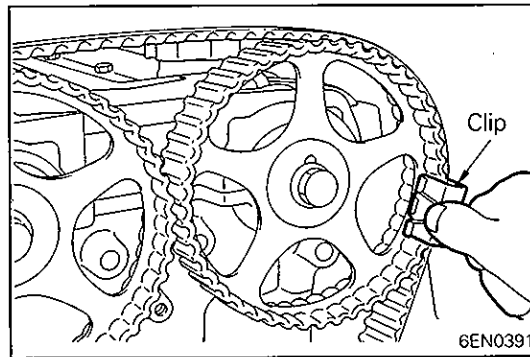

- (5) Thread the timing belt over the intake side camshaft sprocket and fix it at indicated position by a clip.

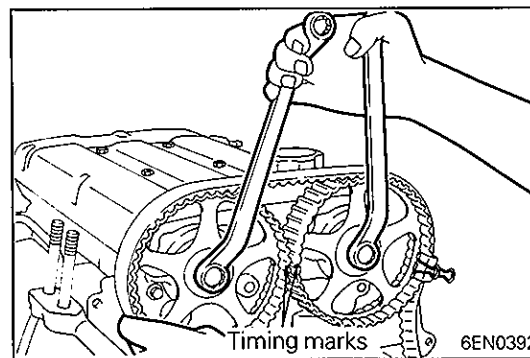

- (6) Thread the timing belt over the exhaust side sprocket, aligning the timing marks with the cylinder head top surface using two wrenches.

11A-4-8 ENGINE – Drive Belt and Timing Belt (Double Camshaft Engine)

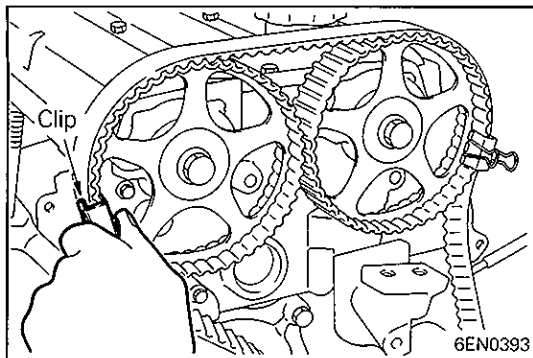

(7) Fix the belt at indicated position by a clip.

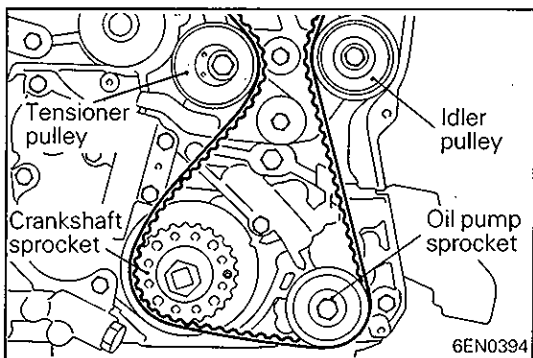

(8) Thread the timing belt over the idler pulley, the oil pump sprocket, the crankshaft sprocket and the tensioner pulley in the order shown.

(9) Remove the two clips.

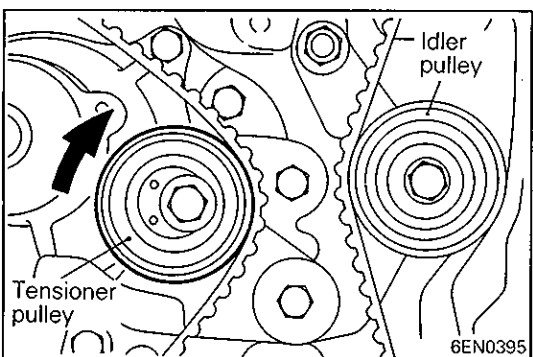

(10) Lift up the tensioner pulley in the direction of arrow and tighten the center bolt.

(11) Check to see that all timing marks are lined up.

(12) Remove the screwdriver inserted in step (4) and fit the plug. (Engine with silent shafts)

(13) Give the crankshaft a quarter counter-clockwise turn. Then, turn it clockwise until the timing marks are lined up again.

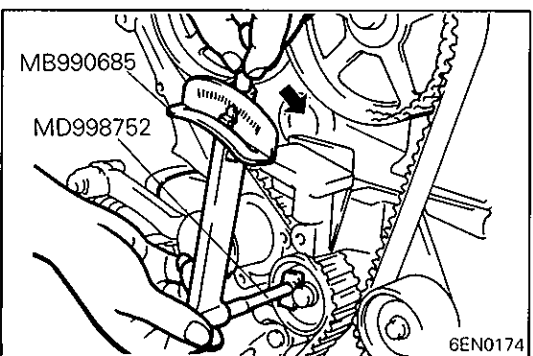

(14) Install the special tools, Socket Wrench and Torque Wrench, on the tensioner pulley, and loosen the tensioner pulley center bolt.

NOTE

If the special tool is not available, use a commercially available torque wrench that is capable of measuring 0 – 3 Nm (0 – 0.3 kgm, 0 – 2.2 ft.lbs.).

(15) Torque to 2.6 – 2.8 Nm (0.26 – 0.28 kgm, 1.88 – 2.03 ft.lbs.) with the torque wrench.

(16) Holding the tensioner pulley with the special tool and torque wrench, tighten the center bolt to specification.

(17) Remove the set wire from the auto tensioner rod. Remove wire pulling by fingers.

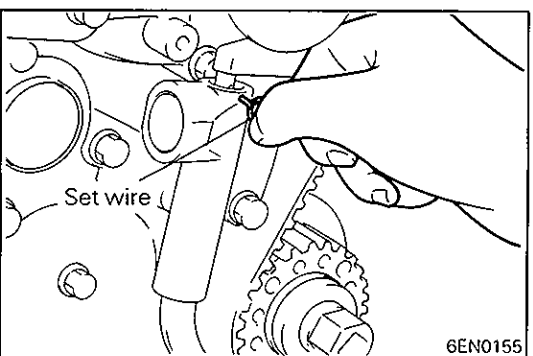

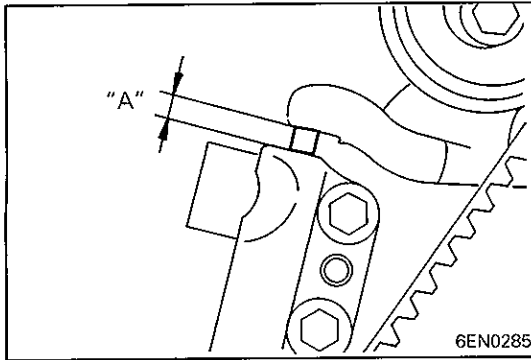

- (18) Rotate the crankshaft two complete turns clockwise and leave it as is for about 15 minutes.
- (19) Measure the distance "A" (between the tensioner arm and auto tensioner body). If it is out of specification, repeat steps (14) through (19) until the specified value is obtained.
Standard value: 3.8 – 4.5 mm (0.15 – 0.18 in.)

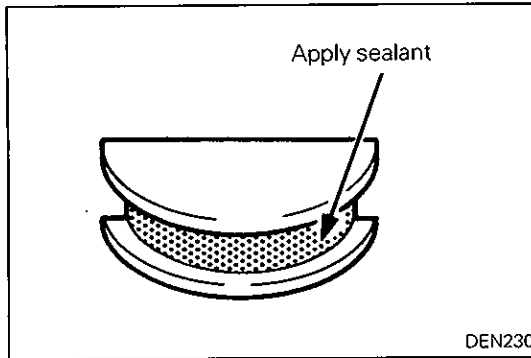

APPLICATION OF SEALANT ON SEMI-CIRCULAR PACKING

Specified sealant: 3M ATD Part No. 8660 or equivalent

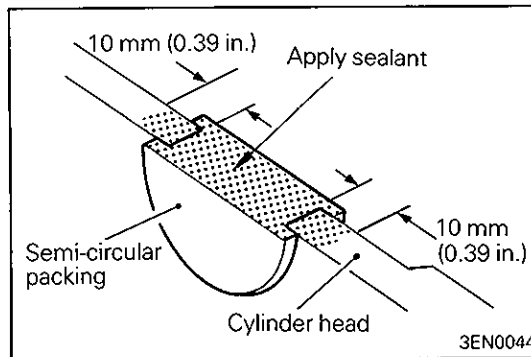

11A-4-10ENGINE – Drive Belt and Timing Belt (Double Camshaft Engine)

▶J▶ APPLICATION OF SEALANT ON ROCKER COVER

Apply sealant to the areas indicated in the illustration.

Specified sealant: 3M ATD Part No. 8660 or equivalent

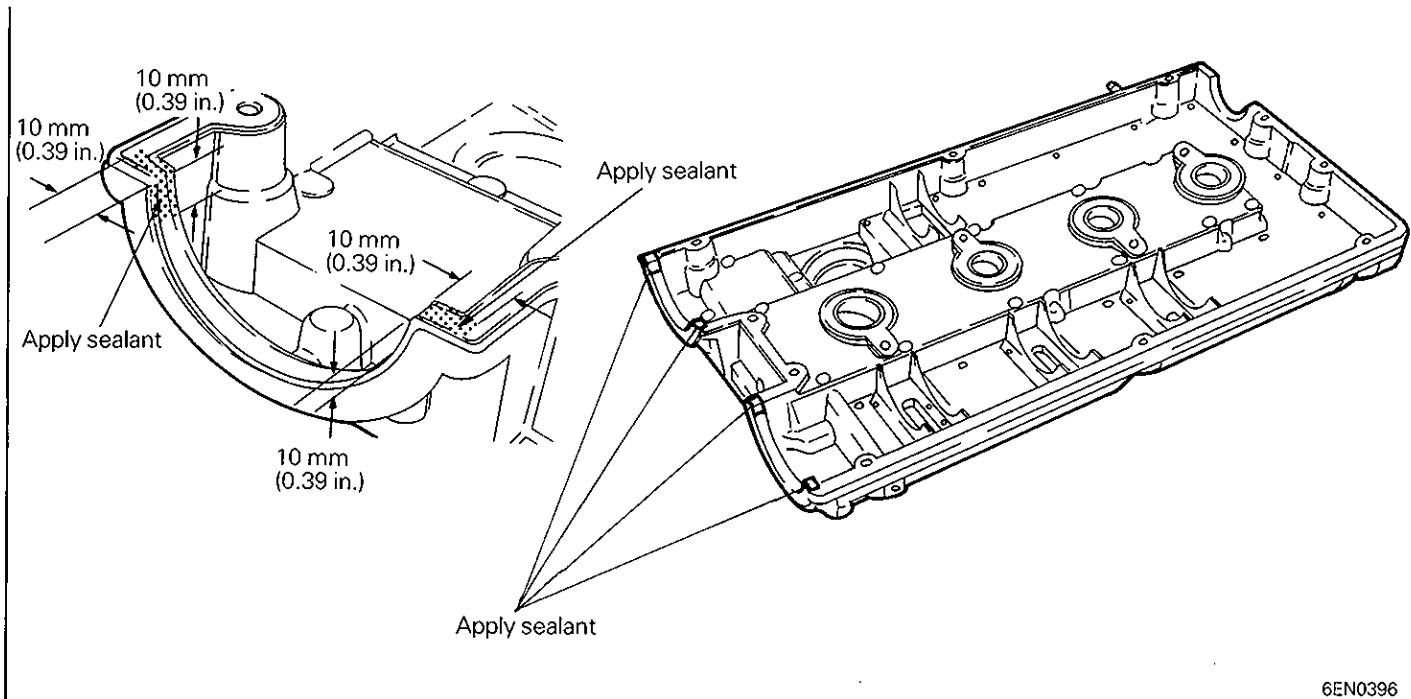

6EN0396

▶K▶ ADJUSTMENT OF DRIVE BELT TENSION

Refer to "▶G▶ ADJUSTMENT OF DRIVE BELT TENSION" on page 11A-3-8.

2/11

5. INTAKE MANIFOLD

REMOVAL AND INSTALLATION (CARBURETOR ENGINE)

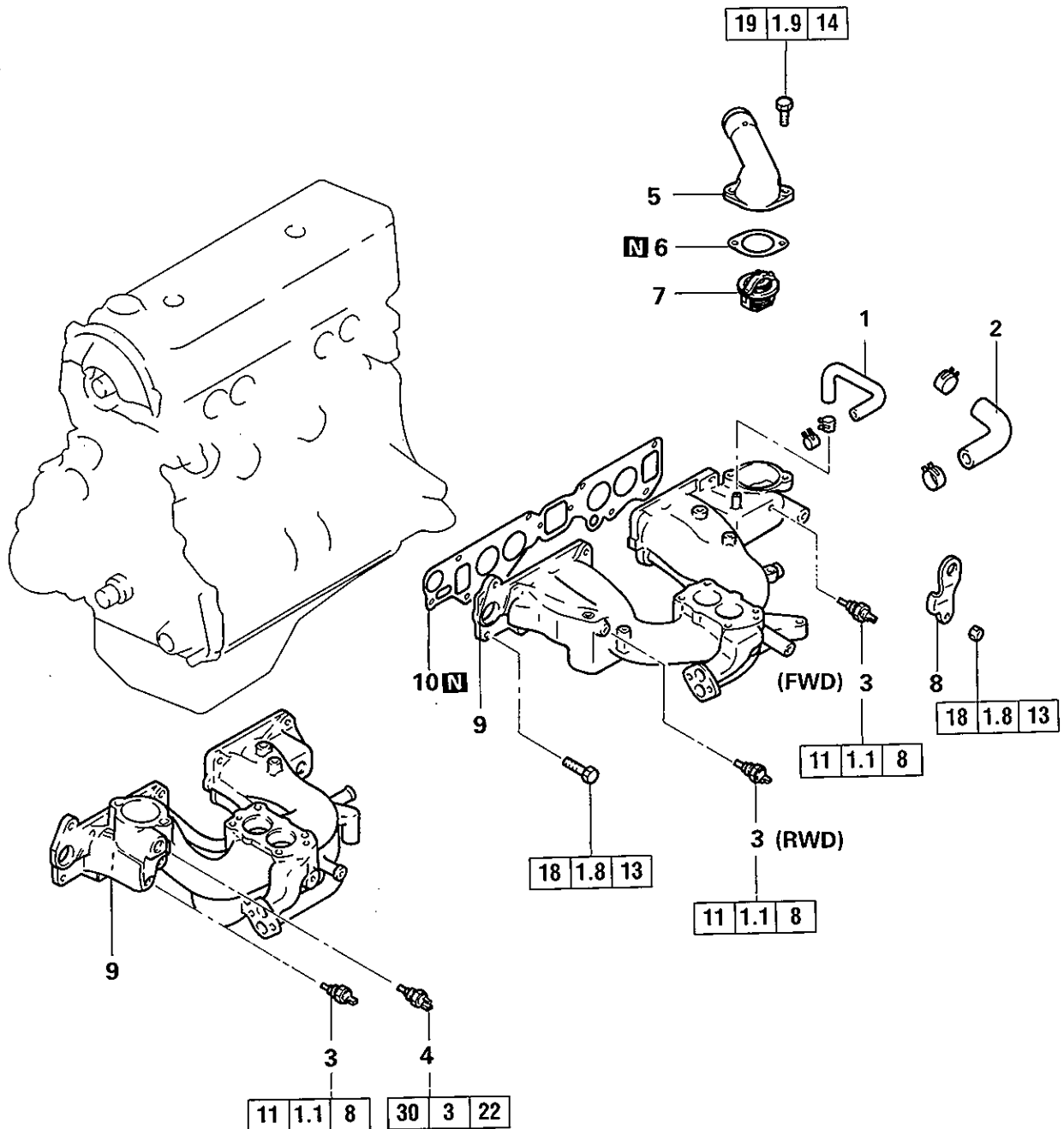

Removal steps

1. Water hose
2. Water by-pass hose
- ▶D▶ 3. Engine coolant temperature gauge unit
- ▶C▶ 4. Engine coolant temperature sensor (Electronic carburettor)
5. Water outlet fitting
- ▶B▶ 6. Gasket
7. Thermostat
8. Engine hanger
9. Intake manifold
10. Intake manifold gasket

REMOVAL AND INSTALLATION (FUEL INJECTION, SINGLE CAMSHAFT ENGINE)

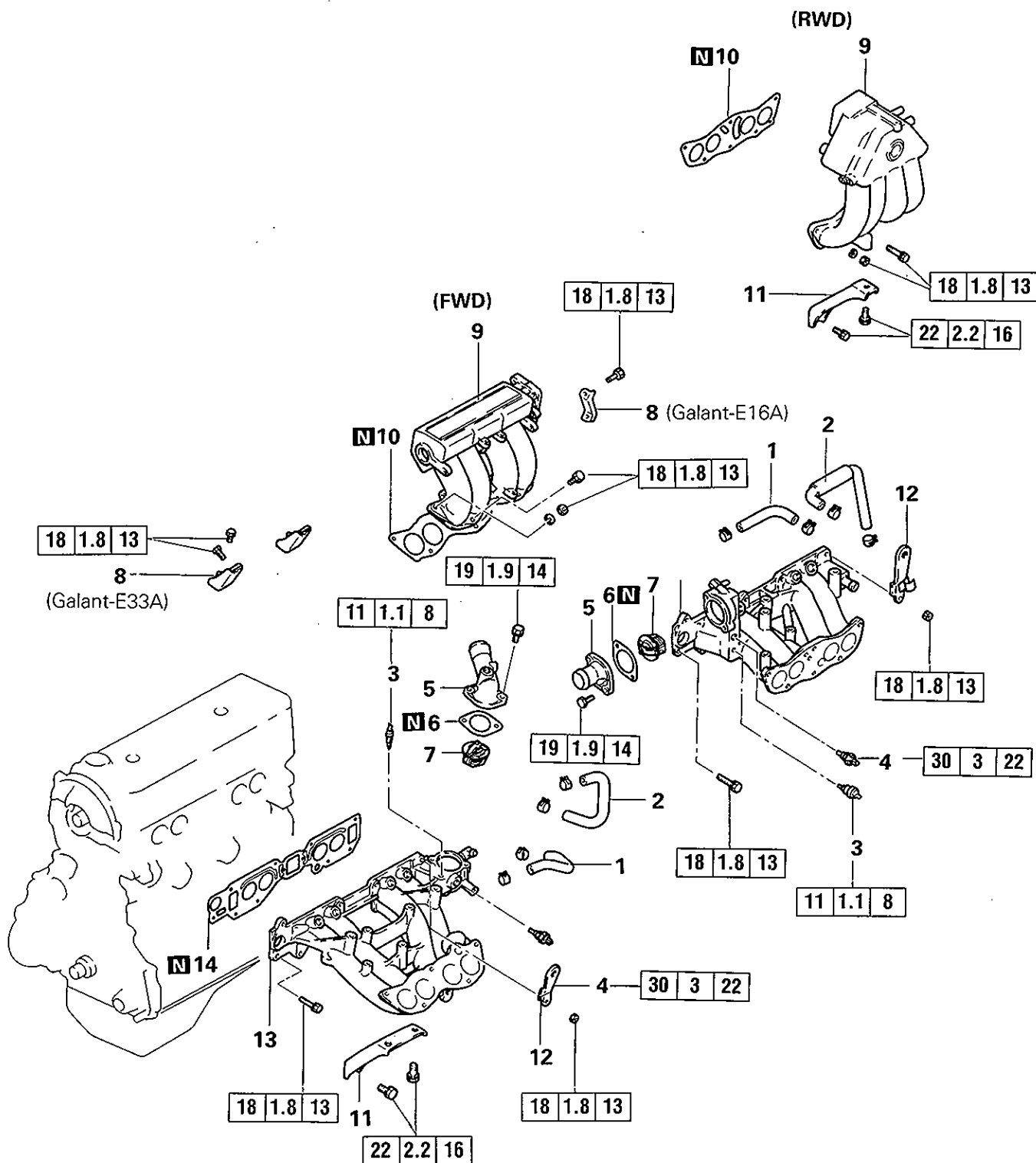

Removal steps

- | | |
|--|------------------------------|
| 1. Water hose | 8. Air intake plenum stay |
| 2. Water hose | 9. Air intake plenum |
| ▶D▶ 3. Engine coolant temperature gauge unit | 10. Air intake plenum gasket |
| ▶C▶ 4. Engine coolant temperature sensor | 11. Intake manifold stay |
| 5. Water outlet fitting | 12. Engine hanger |
| ▶B▶ 6. Gasket | 13. Intake manifold |
| 7. Thermostat | 14. Intake manifold gasket |

REMOVAL AND INSTALLATION (FUEL INJECTION, DOUBLE CAMCHAFT ENGINE)

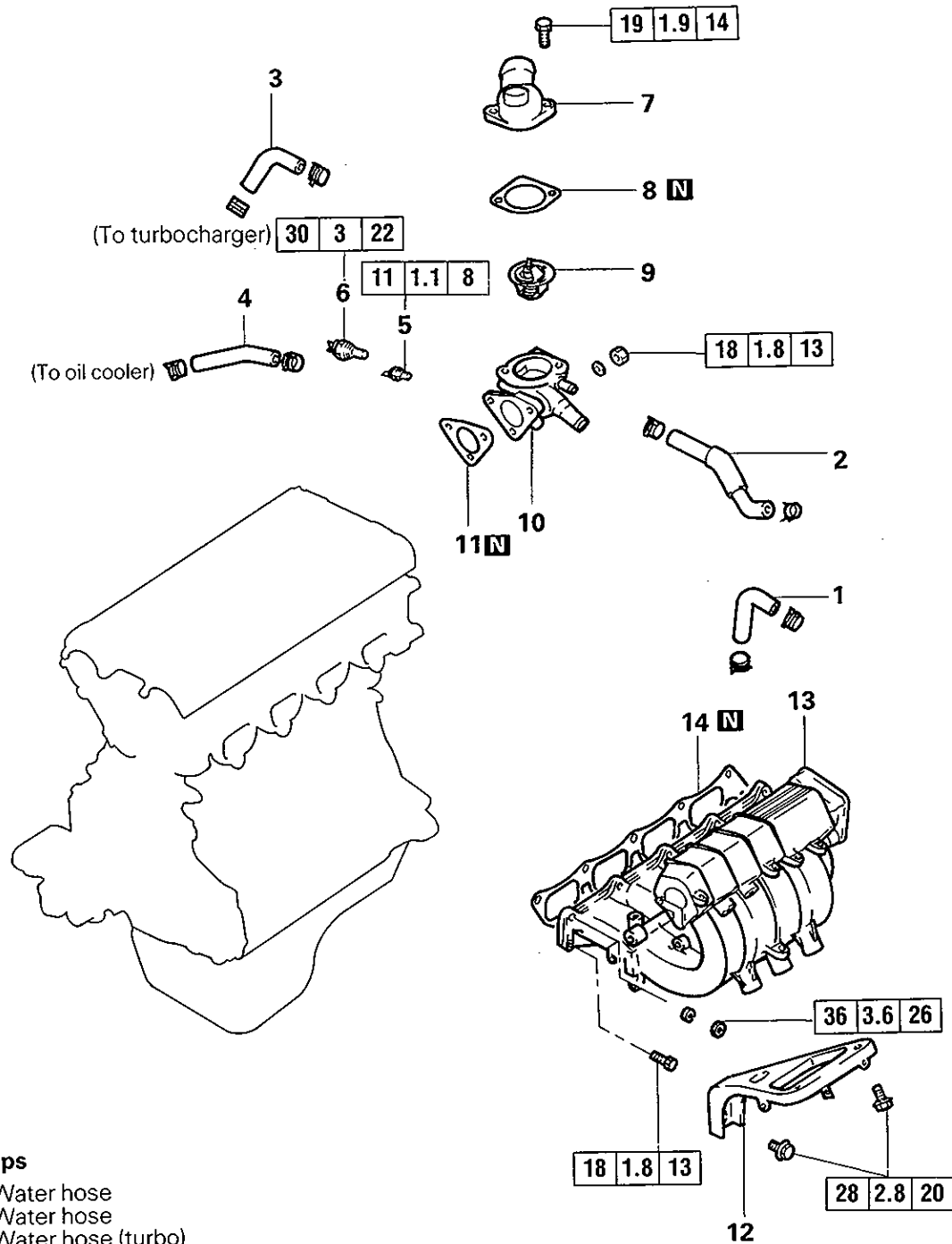

Removal steps

1. Water hose
2. Water hose
3. Water hose (turbo)
4. Water hose (turbo)
- ◆D◆ 5. Engine coolant temperature gauge unit
- ◆C◆ 6. Engine coolant temperature sensor
- ◆B◆ 7. Water outlet fitting
- ◆B◆ 8. Gasket
9. Thermostat
10. Thermostat case
11. Gasket
12. Intake manifold stay
- ◆A◆ 13. Intake manifold
14. Intake manifold gasket

SERVICE POINTS OF INSTALLATION**◆A◆ INSTALLATION OF INTAKE MANIFOLD (FOR DOUBLE CAMSHAFT ENGINE)**

- (1) Tighten the intake manifold bolts, noting that the bolts installed at the locations indicated in the illustration are tightened to a different torque.

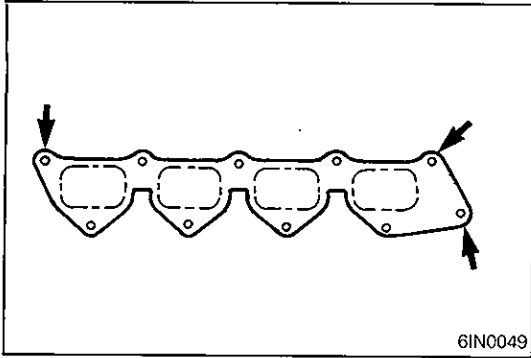
**◆B◆ INSTALLATION OF WATER OUTLET FITTING GASKET FOR RUBBER COATED METAL GASKET ONLY**

- (1) Install the water outlet fitting gasket with its "UP" mark facing up (toward the water outlet fitting side).

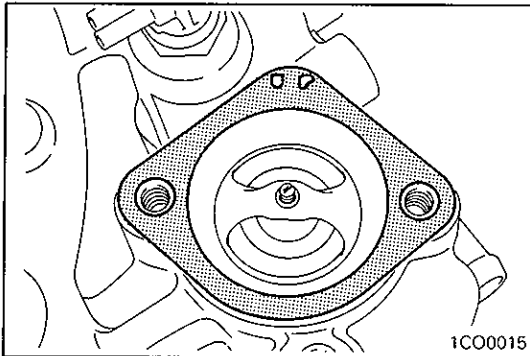
**◆C◆ APPLICATION OF SEALANT TO ENGINE COOLANT TEMPERATURE SENSOR**

Specified sealant: 3M Nut Locking Part No. 4171 or equivalent

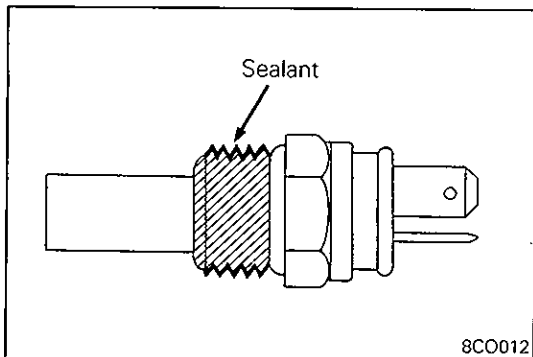
**◆D◆ APPLICATION OF SEALANT TO ENGINE COOLANT TEMPERATURE GAUGE UNIT**

Specified sealant: 3M ATD Part No. 8660 or equivalent

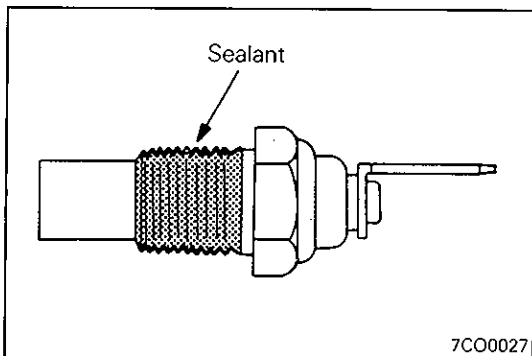

6. EXHAUST MANIFOLD AND WATER PUMP

REMOVAL AND INSTALLATION (SINGLE CAMSHAFT ENGINE)

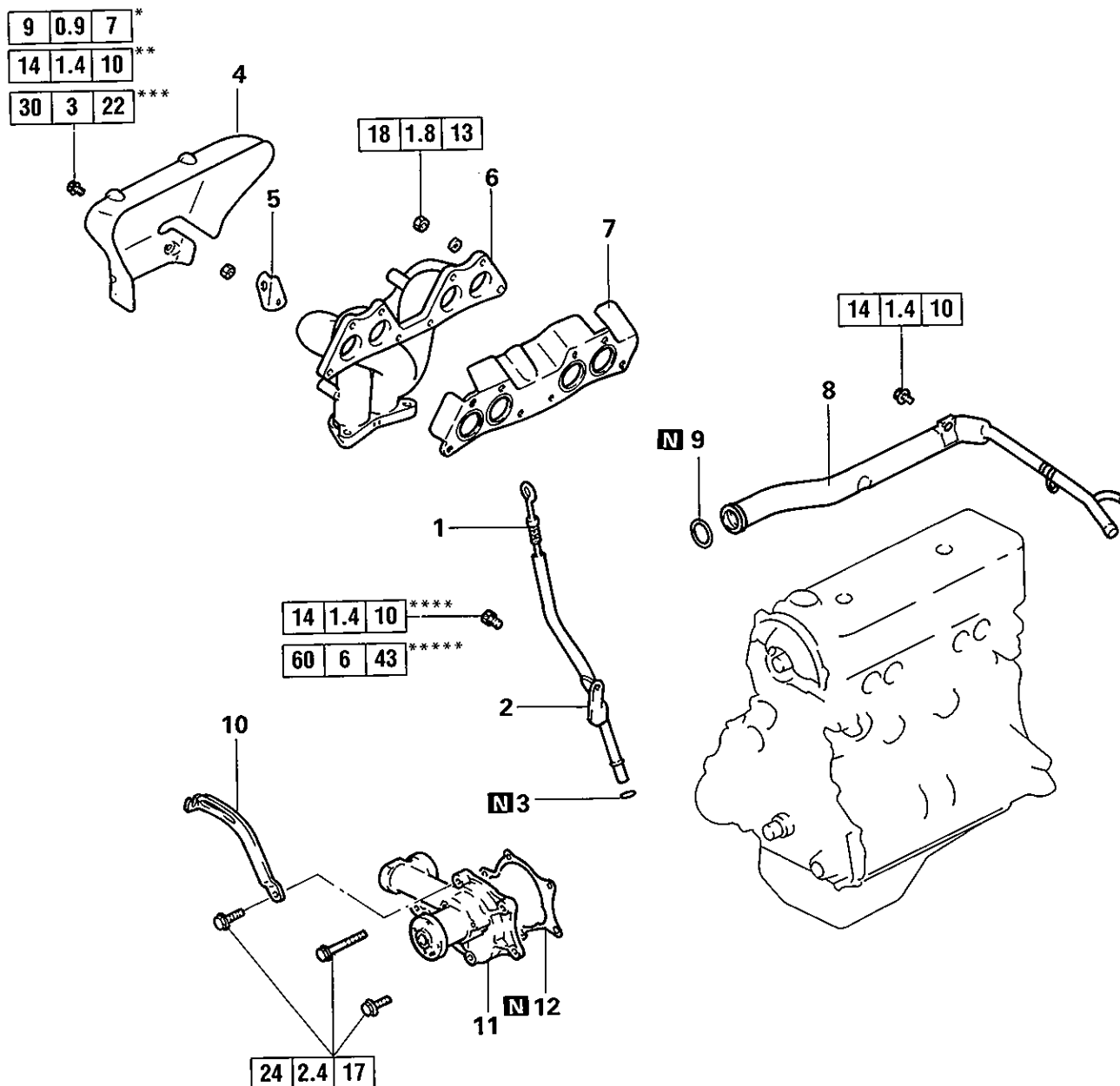

Removal steps

1. Oil level gauge
2. Oil level gauge guide
3. O-ring
4. Heat protector
5. Engine hanger
6. Exhaust manifold
7. Exhaust manifold gasket
8. Water inlet pipe
9. O-ring
10. Alternator brace
11. Water pump
12. Water pump gasket

NOTE

- * : M6 bolt for engine with carburettor
- ** : M8 bolt for engine with MPI
(Except E33A for General Export)
- *** : M8 bolt for engine with carburettor
(Including E33A-MPI for General Export)
- **** : M8 bolt
- ***** : M10 bolt

6EN0481

REMOVAL AND INSTALLATION (DOUBLE CAMSHAFT ENGINE WITHOUT TURBOCHARGER)

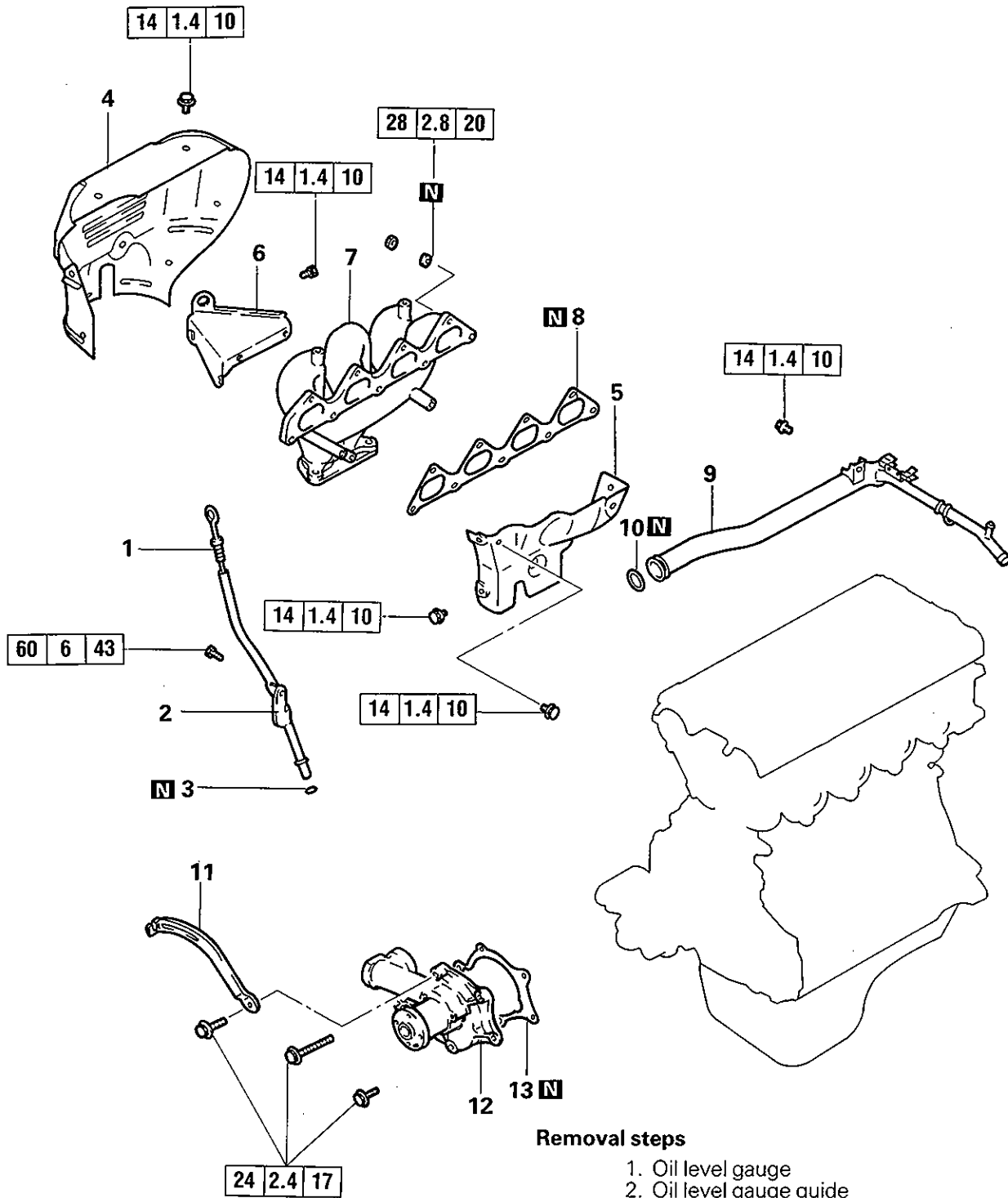

Removal steps

1. Oil level gauge
2. Oil level gauge guide
3. O-ring
4. Heat protector "A"
5. Heat protector "B"
6. Engine hanger
7. Exhaust manifold
8. Exhaust manifold gasket
- ▶B▶ 9. Water inlet pipe
- ▶B▶ 10. O-ring
11. Alternator brace
- ▶A▶ 12. Water pump
13. Gasket

222

REMOVAL AND INSTALLATION (DOUBLE CAMSHAFT ENGINE WITH TURBOCHARGER)

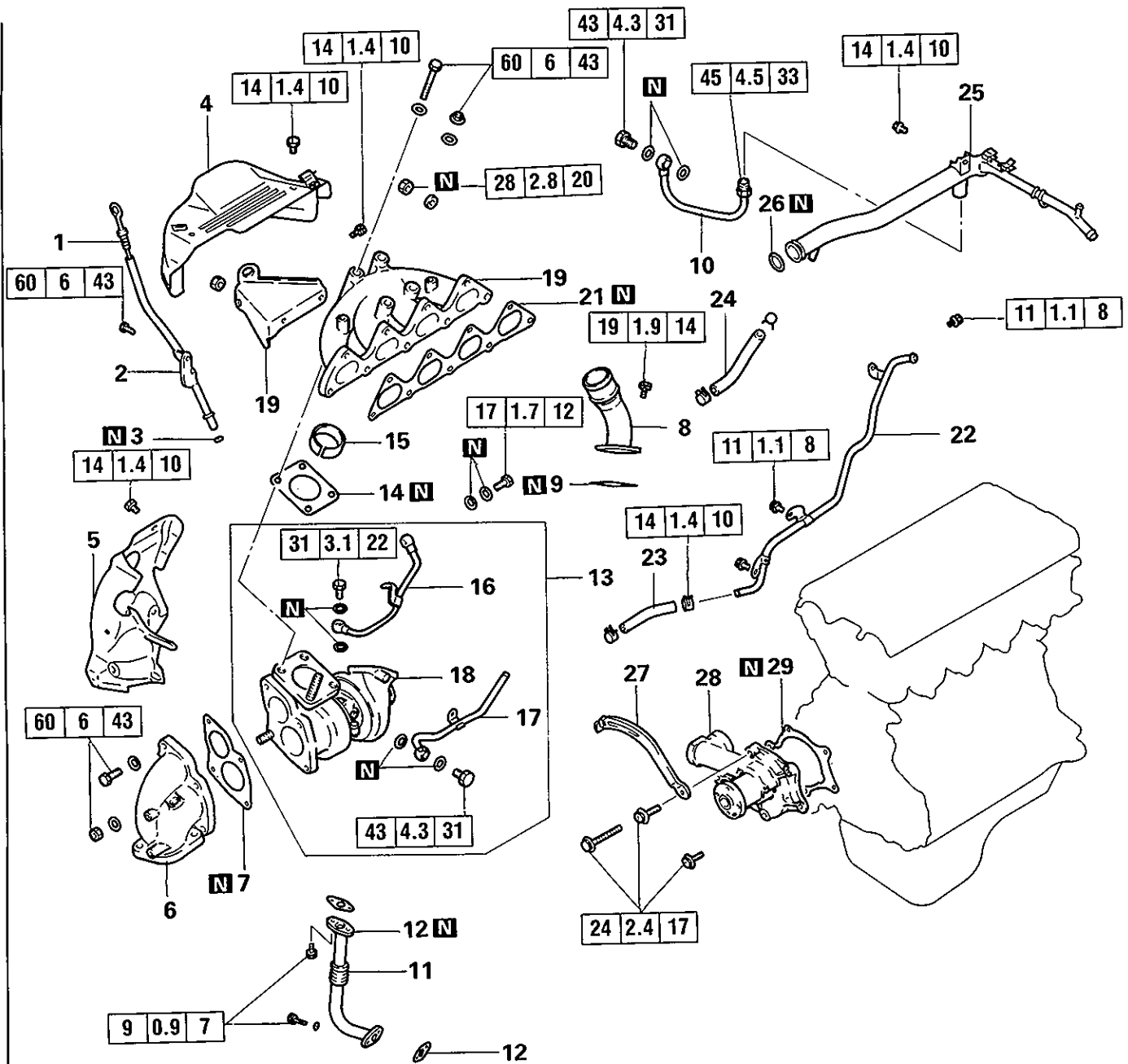

Removal steps

1. Oil level gauge
2. Oil level gauge guide
3. O-ring
4. Heat protector "A"
5. Heat protector "B"
6. Exhaust fitting
7. Gasket
8. Air outlet fitting
9. Gasket
10. Water pipe "B"
11. Oil return pipe
12. Gasket

13. Turbocharger assembly
14. Gasket
15. Ring
16. Oil pipe
17. Water pipe "A"
18. Turbocharger
19. Engine hanger
20. Exhaust manifold
21. Exhaust manifold gasket
22. Water pipe
23. Water hose
24. Water hose
25. Water inlet pipe
26. O-ring
27. Alternator brace
28. Water pump
29. Gasket

SERVICE POINTS OF INSTALLATION**▶A▶ INSTALLATION OF WATER PUMP**

- (1) Clean both gasket surfaces of water pump body and cylinder block.
- (2) The length of water pump mounting bolt is as shown in the illustration.

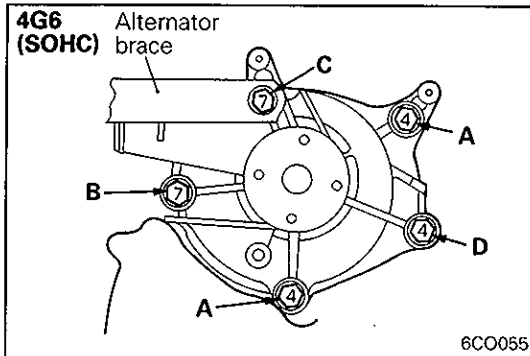
**Bolt length**

- A: 30 mm (1.18 in.)
- B: 40 mm (1.57 in.)
- C: 65 mm (2.56 in.)
- D: 20 mm (0.79 in.)

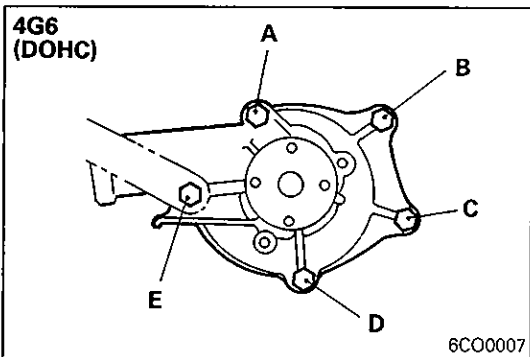
**Bolt length**

- A: 30 mm (1.18 in.)
- B: 22 mm (0.87 in.)
- C: 14 mm (0.55 in.)
- D: 28 mm (1.10 in.)
- E: 65 mm (2.56 in.)

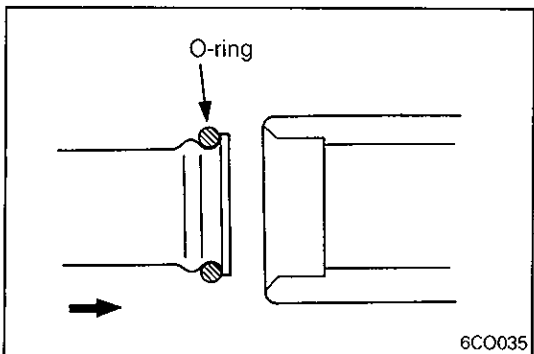
**▶B▶ INSTALLATION OF WATER PIPE/O-RING**

- (1) With the O-ring at the front end of water inlet pipe replaced with a new one, apply water to its outside surface for easier insertion into the water pump body.

NOTE

Never apply engine oil and other lubricant to the O-ring.

7. TURBOCHARGER

DISASSEMBLY AND REASSEMBLY

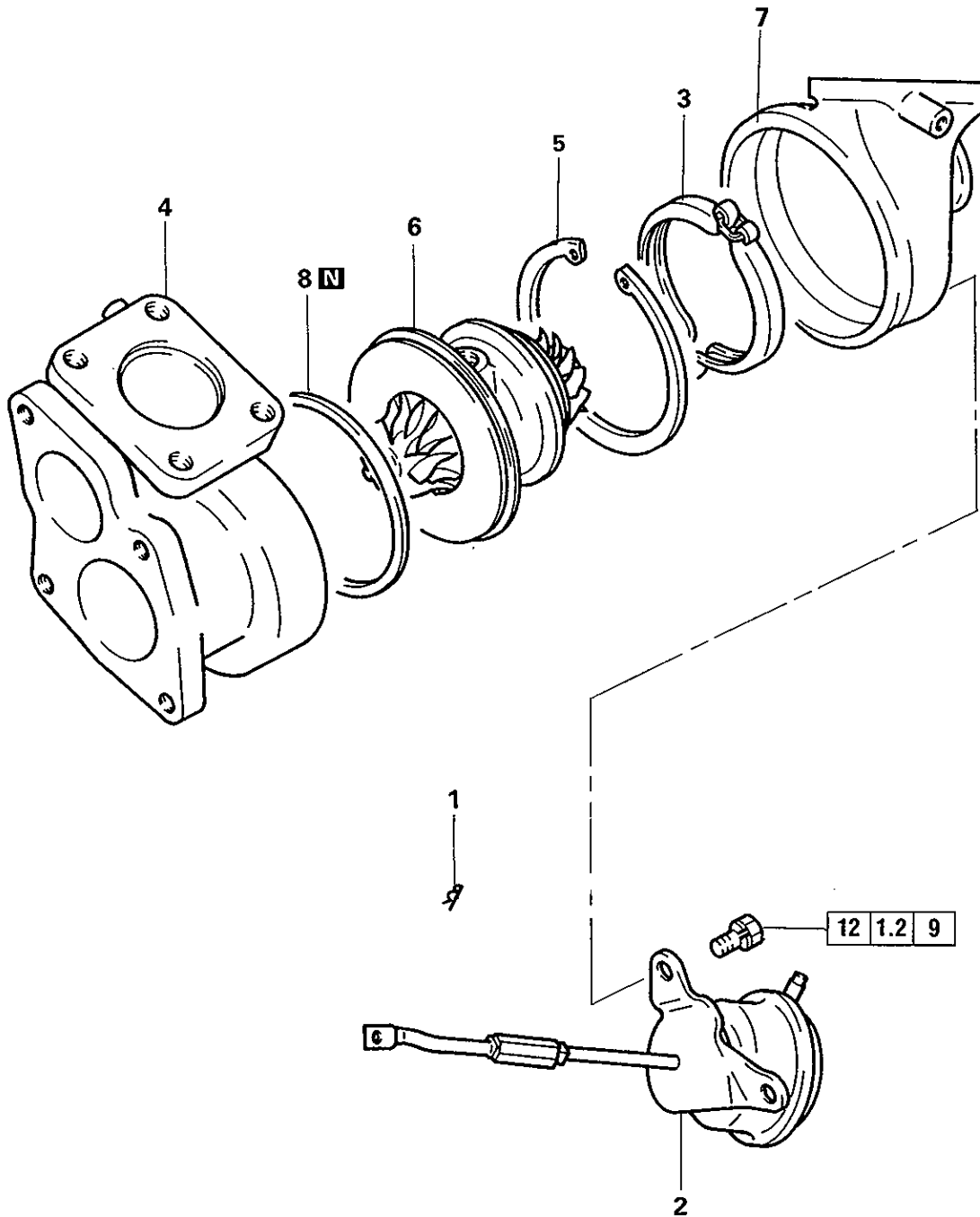

Disassembly steps

- ◆F◆ Inspection of waste gate actuator operation
- 1. Snap pin
- 2. Waste gate actuator
- ◆E◆ 3. Coupling
- ◆D◆ 4. Turbine housing
- ◇A◇ ◆C◆ 5. Snap ring
- ◇B◇ ◆B◆ 6. Turbine wheel assembly
- 7. Compressor cover
- 8. Gasket
- ◆A◆ 9. O-ring

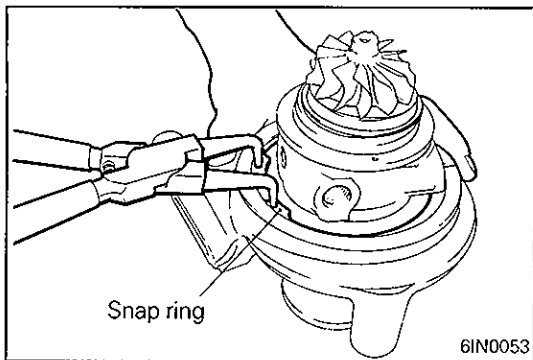

SERVICE POINTS OF DISASSEMBLY

◁A▷ REMOVAL OF SNAP RING

- (1) Lay the unit with the compressor cover side facing down and using snap ring pliers, remove the compressor cover attaching snap ring.

Caution

- When removing the snap ring, hold it with fingers to prevent it from springing away.

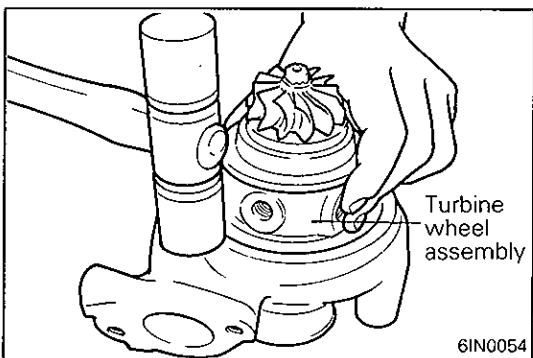

◁B▷ REMOVAL OF TURBINE WHEEL ASSEMBLY

- (1) Remove the turbine wheel assembly, striking the circumference of the compressor cover with a plastic hammer. The turbine wheel assembly may be a little hard to remove due to an O-ring put on the outer circumference.

CLEANING

- (1) Use a clean cleaning oil commercially available. Do not use corrosive cleaning oils as they could damage to some parts.
- (2) Use a plastic scraper or hard brush to clean aluminum parts.

INSPECTION

TURBINE HOUSING

- (1) Check the housing for traces of contact with the turbine wheel, cracks due to overheating, pitching, deformation and other damage. Replace with a new turbine housing if cracked.
- (2) Operate the waste gate valve lever manually to check that the gate can be opened and closed smoothly.

COMPRESSOR COVER

- (1) Check the compressor cover for traces of contact with the compressor wheel and other damage.

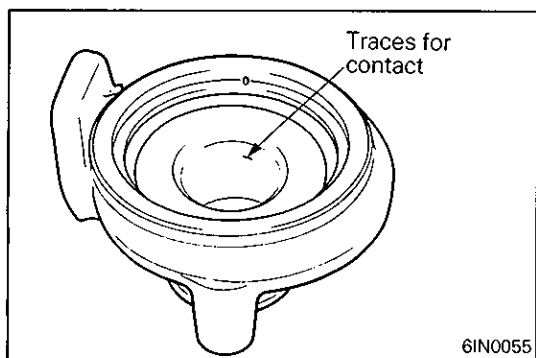

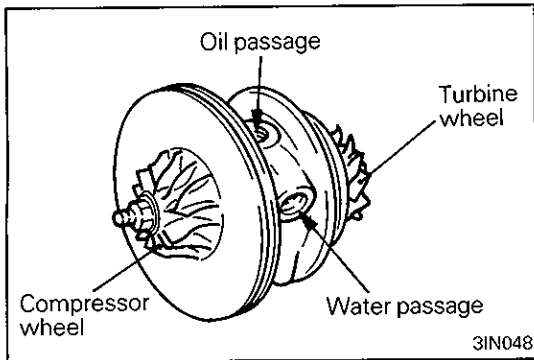
**TURBINE WHEEL ASSEMBLY**

- (1) Check the turbine and compressor wheel blades for bend, burr, damage, corrosion and traces of contact on the back side and replace if defective.
- (2) Check the oil passage of the turbine wheel assembly for deposit and clogging.
- (3) In the case of water cooled type, check also the water passage for deposit and clogging.
- (4) Check the turbine wheel and compressor wheel for light and smooth turning.

OIL PIPE/OIL RETURN PIPE

- (1) Correct or replace the oil pipe and oil return pipe if clogged, collapsed, deformed or otherwise damaged.

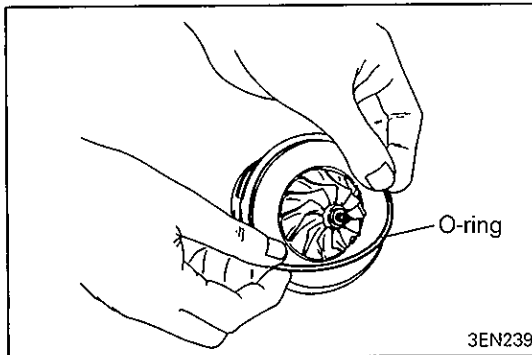
**SERVICE POINTS OF REASSEMBLY****◆A◆ INSTALLATION OF O-RING**

- (1) Apply a light coat of engine oil to a new O-ring and fit in the turbine wheel assembly groove.

Caution

- When installing the O-ring, use care not to damage it. A damaged O-ring causes oil leaks.

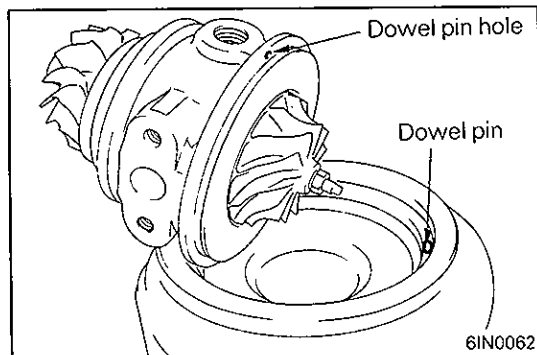
**◆B◆ INSTALLATION OF TURBINE WHEEL ASSEMBLY**

- (1) Apply a light coat of engine oil to the periphery of the O-ring.
- (2) Install the turbine wheel assembly to the compressor cover in relation to the dowel pin.

Caution

- Use care not to damage the blades of turbine wheel and compressor wheel.

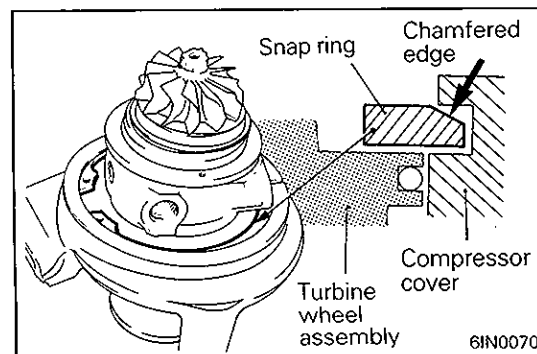
**◆C◆ INSTALLATION OF SNAP RING**

- (1) Lay the assembly with the compressor cover facing down and fit the snap ring.

Caution

- Fit the snap ring with its chamfered side facing up.

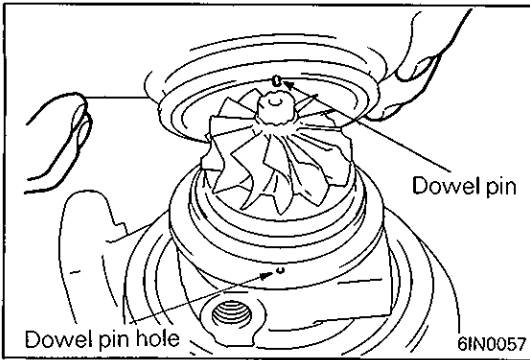

▶D▶ INSTALLATION OF TURBINE HOUSING

- (1) Install the turbine housing in relation to the dowel pin.

Caution

- Use care not damage the blades of turbine wheel.

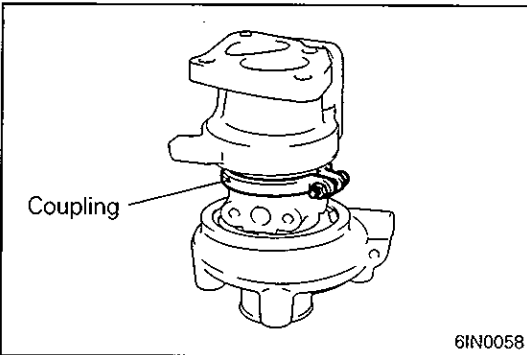

▶E▶ INSTALLATION OF COUPLING

- (1) Install the coupling and tighten to specified torque.

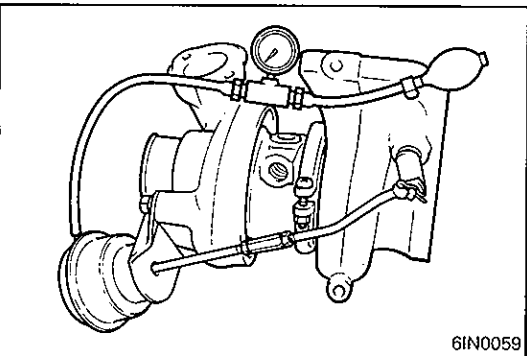

▶F▶ INSPECTION OF WASTE GATE ACTUATOR OPERATION

- (1) Using a tester, apply a pressure of approx. 72 kPa (0.73 kg/cm², 10.3 psi) to the actuator and make sure that the rod moves.

Caution

- Do not apply a pressure of more than 85 kPa (0.87 kg/cm², 12.4 psi) to the actuator. Otherwise, diaphragm may be damaged.
Never attempt to adjust the waste gate valve.

8. ROCKER ARMS AND CAMSHAFT (SINGLE CAMSHAFT ENGINE) REMOVAL AND INSTALLATION

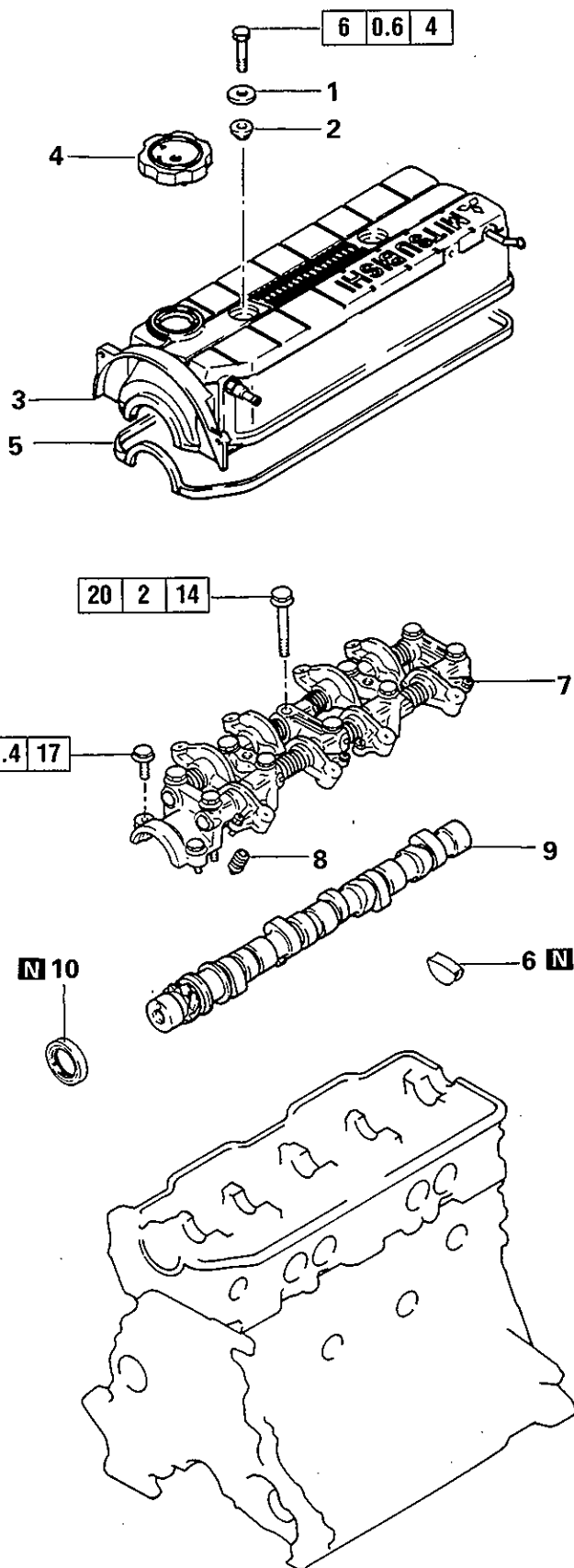

Removal steps

1. Washer
2. Oil seal
3. Rocker cover
4. Oil filler cap
5. Gasket
6. Semi-circular packing
7. Rocker arms and shafts
- ◆A◆ 8. Lash adjuster
9. Camshaft
10. Camshaft oil seal

Installation steps

9. Camshaft
- ◆A◆ 8. Lash adjuster
7. Rocker arms and shafts
- ◆B◆ 10. Camshaft oil seal
- ◆C◆ Valve clearance adjustment
- ◆D◆ 6. Semi-circular packing
5. Gasket
4. Oil filler cap
3. Rocker cover
2. Oil seal
1. Washer

11A-8-2 ENGINE – Rocker Arms and Camshaft (Single Camshaft Engine)

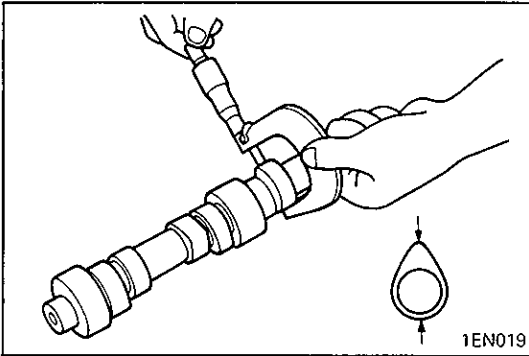
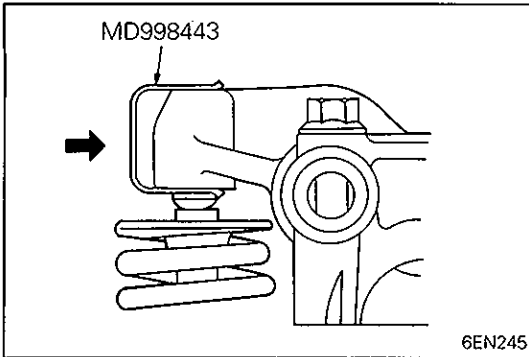

SERVICE POINTS OF REMOVAL

◊A◊ REMOVAL OF LASH ADJUSTERS

- (1) Before removing rocker arms and shafts assembly, install the special tool as illustrated to prevent adjuster from dropping.

INSPECTION

CAMSHAFT

- (1) Check camshaft journals and cam lobes for excessive wear or damage. Replace if defects are evident.
- (2) Measure the cam height and, if the limit is exceeded, replace.

Unit: mm (in.)

Identification mark	Standard value	Limit
1 : Intake	42.17 (1.6600)	41.67 (1.6405)
Exhaust	42.23 (1.6626)	41.73 (1.6429)
3 : Intake	42.48 (1.6724)	41.98 (1.6528)
Exhaust	42.55 (1.6752)	42.05 (1.6555)
A : Intake	42.08 (1.6565)	41.58 (1.6370)
Exhaust	42.08 (1.6565)	41.58 (1.6370)
C.D.E : Intake	42.40 (1.6692)	41.90 (1.6496)
Exhaust	42.40 (1.6692)	41.90 (1.6496)
AR : Intake	44.53 (1.7531)	44.03 (1.7335)
Exhaust	44.53 (1.7531)	44.03 (1.7335)

NOTE

The camshaft identification mark is stamped on the opposite end of the camshaft sprocket side.

LEAK DOWN TEST OF LASH ADJUSTER

Caution

- The lash adjuster is a precision part. Keep it free from dust and other foreign matters.
- Do not disassemble lash adjuster.
- When cleaning lash adjuster, use clean diesel fuel.

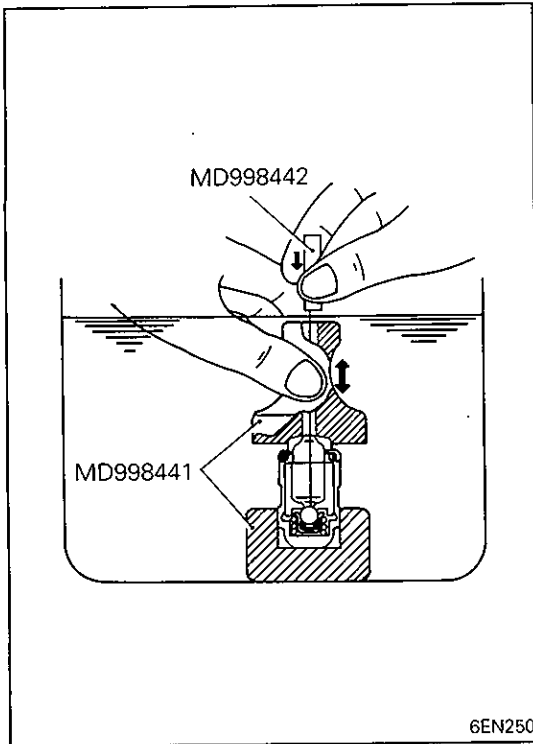

- (1) Immerse the lash adjuster in clean diesel fuel.
- (2) While lightly pushing down inner steel ball using the special tool (Air bleed wire MD998442), move the plunger up and down four or five times to bleed air.

Use the special tool (Retainer MD998441) for the lash adjuster installed to the rocker arm to facilitate the bleeding.

- (3) Remove the special tool (Air bleed wire) and press the plunger. If plunger is hard to be pushed in, the lash adjuster is normal. If the plunger can be pushed in all the way readily, bleed the lash adjuster again. If the plunger is still loose, replace the lash adjuster.

Caution

- Upon completion of air bleeding, hold auto-lash adjuster upright to prevent inside diesel fuel from spilling.

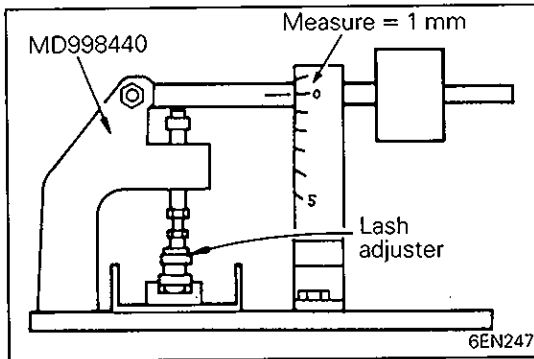

- (4) After air bleeding, set lash adjuster on the special tool (Leak down tester MD998440).
- (5) After plunger has gone down somewhat [0.2 – 0.5 mm], measure time taken for it to go down 1 mm. Replace if measured time is out of specification.

Standard value: 4 – 20 seconds / 1 mm
[Diesel fuel at 15 – 20°C (59 – 68°F)]

SERVICE POINTS OF INSTALLATION

▶▶ INSTALLATION OF LASH ADJUSTERS

- (1) Insert lash adjuster from below as illustrated, using care not to spill diesel fuel from inside of adjuster. Then, install the special tool to prevent adjuster from dropping.

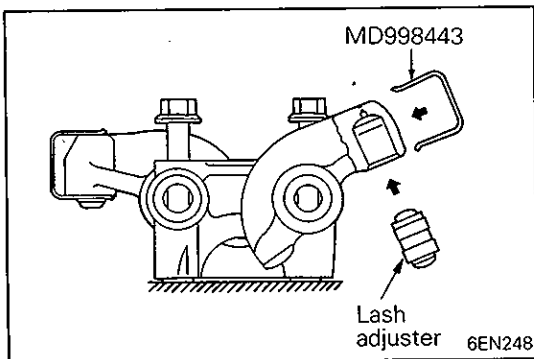

▶▶ INSTALLATION OF CAMSHAFT OIL SEAL

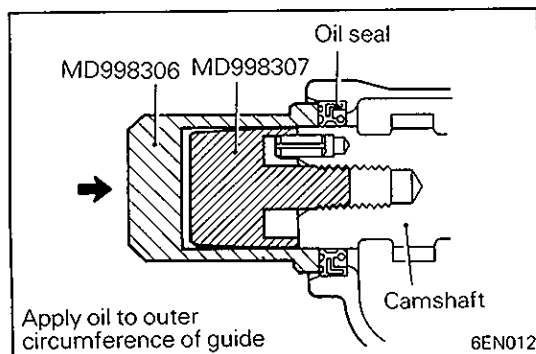

11A-8-4 ENGINE – Rocker Arms and Camshaft (Single Camshaft Engine)

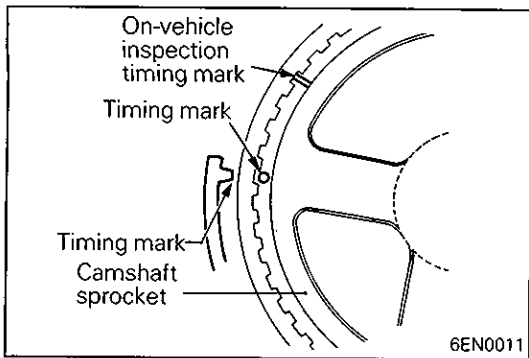

VALVE CLEARANCE ADJUSTMENT

- Turn the crankshaft clockwise and align the timing mark on camshaft sprocket with that on cylinder head.

Caution

- Do not mistake the timing mark for the on-vehicle inspection timing mark. (Front-engine front-wheel drive vehicle only)

- Adjust the valve clearance at points shown in the illustration.

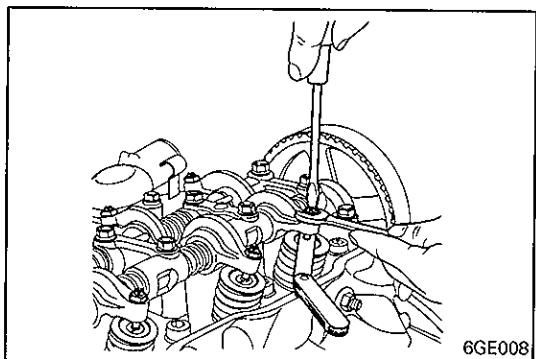
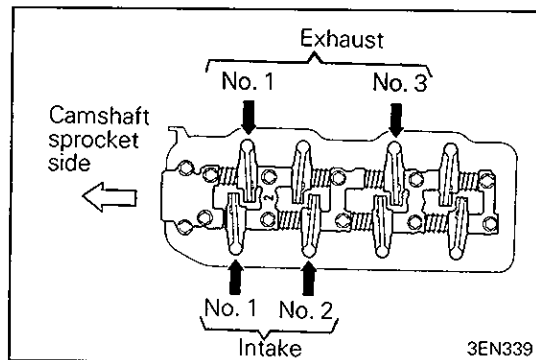

- Loosen the adjusting screw lock nut.
- Using a thickness gauge, adjust the valve clearance by turning the adjusting screw.

Standard value: on cold engine

0.08 mm (0.0031 in.)	Intake
0.18 mm (0.0071 in.)	Exhaust

- While holding the adjusting screw with a screwdriver, tighten the lock nut.

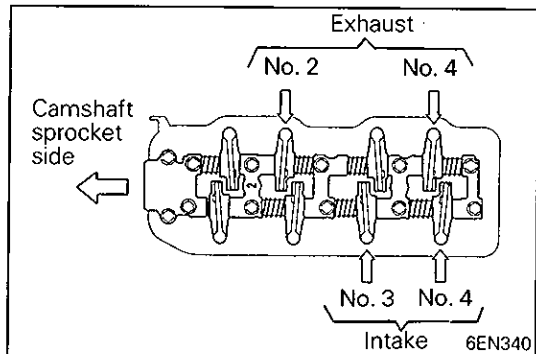

- Rotate clockwise the crankshaft one complete turn (360 degrees).
- Adjust the valve clearance at points shown in the illustration.
- Repeat steps (3) to (5) to adjust the valve clearance of remaining valves.

NOTE

With the engine mounted on vehicle, warm up the engine. Then, check for valve clearance on hot engine and adjust if necessary.

Standard value: on hot engine

0.15 mm (0.0059 in.)	Intake
0.25 mm (0.0098 in.)	Exhaust

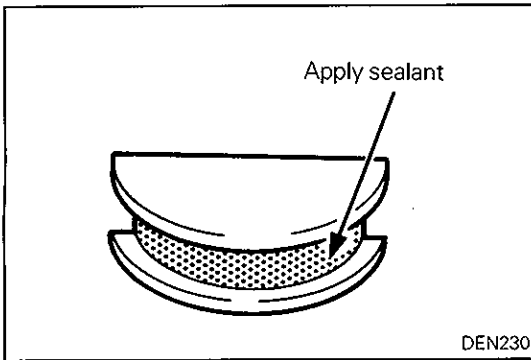

◆D◆ INSTALLATION OF SEMI-CIRCULAR PACKING

Specified sealant:

3M ATD Part No. 8660 or equivalent

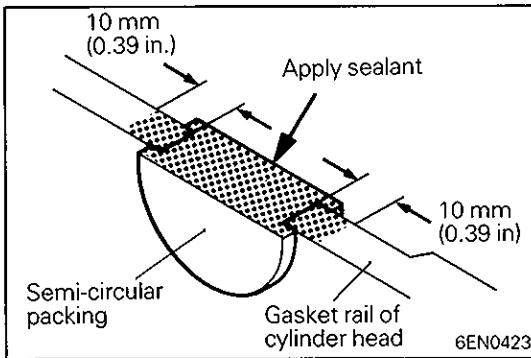

NOTES

9. CAMSHAFTS AND ROCKER ARMS (DOUBLE CAMSHAFT ENGINE) REMOVAL AND INSTALLATION

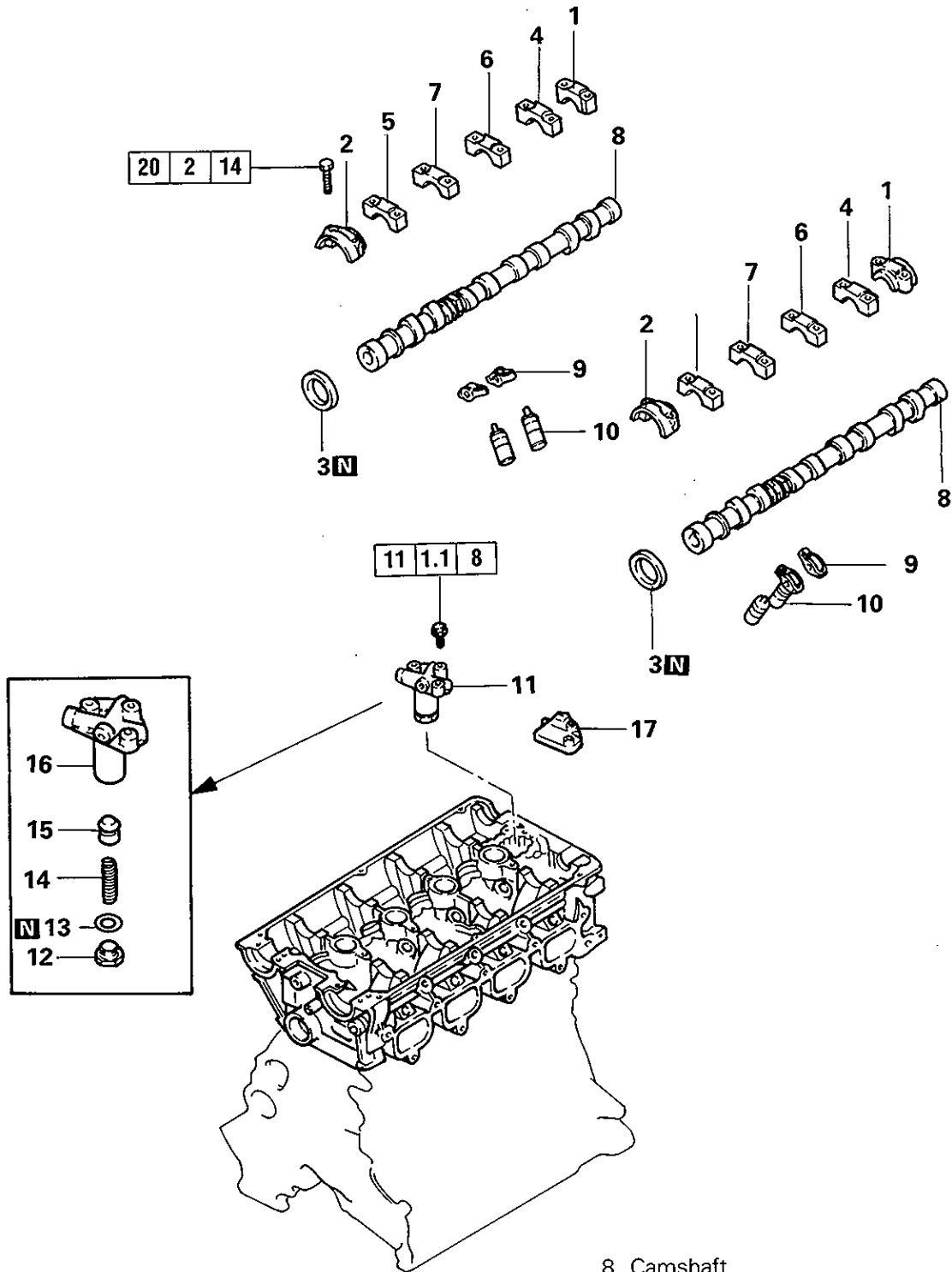

Removal steps

- ◆◆ 1. Bearing cap rear
- ◆◆ 2. Bearing cap front
- ◆◆ 3. Camshaft oil seal
- ◆◆ 4. Bearing cap No.5
- ◆◆ 5. Bearing cap No.2
- ◆◆ 6. Bearing cap No.4
- ◆◆ 7. Bearing cap No.3

- 8. Camshaft
- 9. Rocker arm
- 10. Lash adjuster
- 11. Valve body assembly
- 12. Plug
- 13. Gasket
- 14. Relief spring
- 15. Relief plunger
- 16. Valve body(Up to Aug. 1989)
- 17. Oil delivery body (From Sep. 1989)

11A-9-2 ENGINE – Camshafts and Rocker Arms (Double Camshaft Engine)

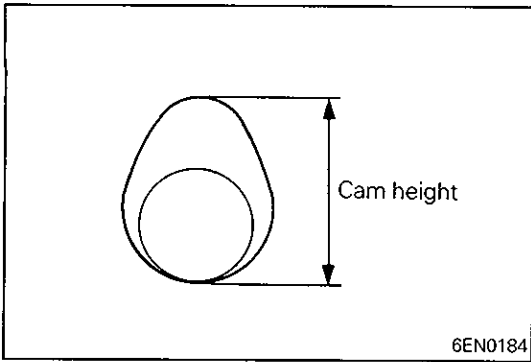

INSPECTION

CAMSHAFT

- (1) Check camshaft journals and cam lobes for excessive wear or damage. Replace if defects are evident.
- (2) Measure the cam height and if the limit is exceeded, replace.

Unit: mm (in.)

Identification mark	Standard value	Limit
A: Intake	35.49 (1.3972)	34.99 (1.3776)
Exhaust	35.20 (1.3858)	34.70 (1.3661)
C: Intake	35.79 (1.4091)	35.29 (1.3894)
Exhaust	35.49 (1.3972)	34.99 (1.3776)
D: Intake	35.49 (1.3972)	34.99 (1.3776)
Exhaust	35.49 (1.3972)	34.99 (1.3776)
E: Intake	35.20 (1.3858)	34.70 (1.3661)
Exhaust	34.91 (1.3744)	34.41 (1.3547)
G: Intake	35.79 (1.4091)	35.29 (1.3894)
Exhaust	35.49 (1.3972)	34.99 (1.3776)

NOTE

The camshaft identification mark is stamped on the opposite end of the camshaft sprocket side.

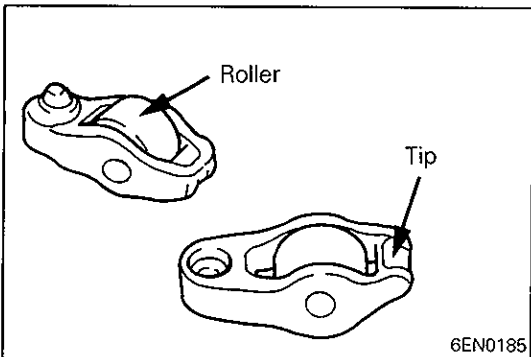

ROCKER ARM

- (1) Visually check the roller and replace if dent, damage, or seizure is evident.
- (2) Check the roller for smooth rotation. Replace if it binds or there is an excessive play.
- (3) Check the valve contact surface for possible damage or seizure and replace as necessary.

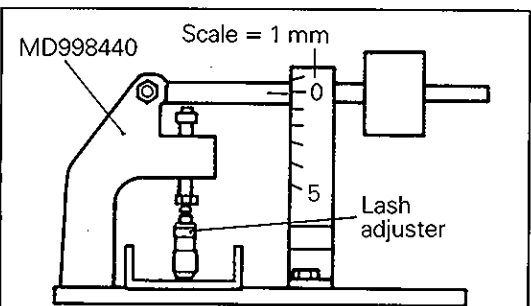

LEAK DOWN TEST OF LASH ADJUSTER

Refer to "LEAK DOWN TEST OF LASH ADJUSTER" on page 11A-8-2 and -3, noting that when the lash adjuster is set in the tester, the adjusting screw is removed from the tester as illustrated and adjustment is made according to the height of the lash adjuster.

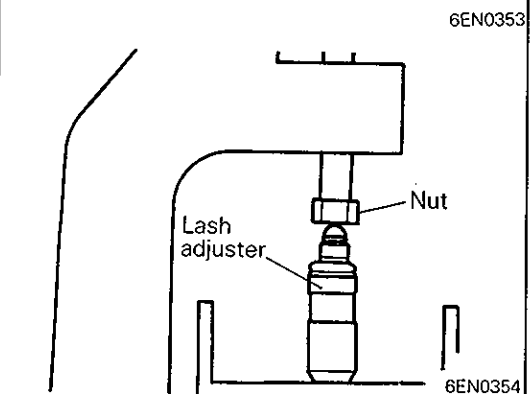

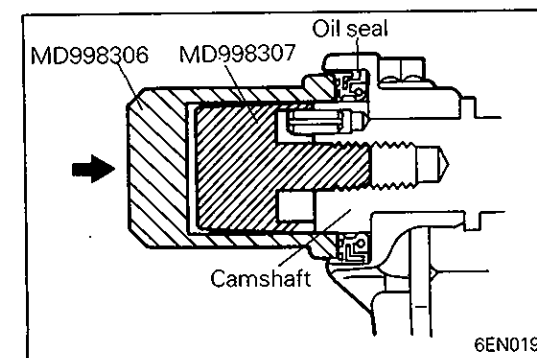
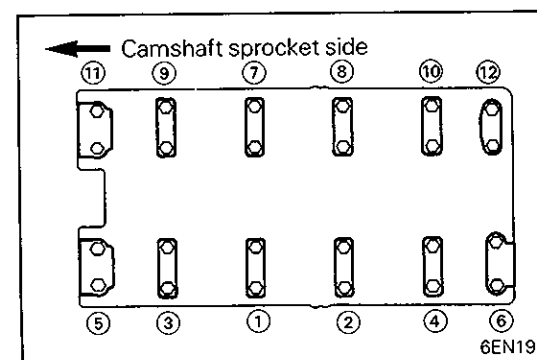
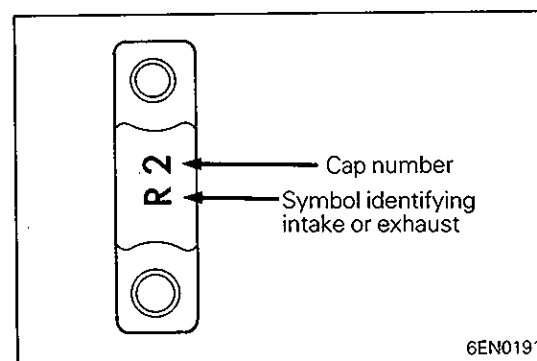
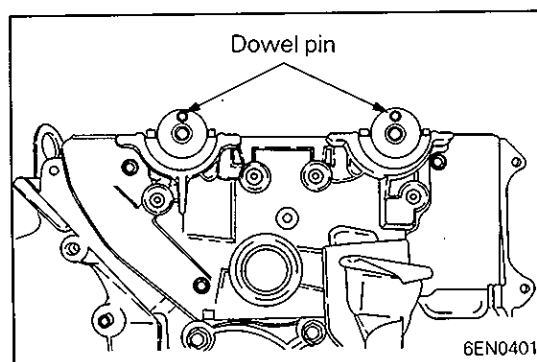
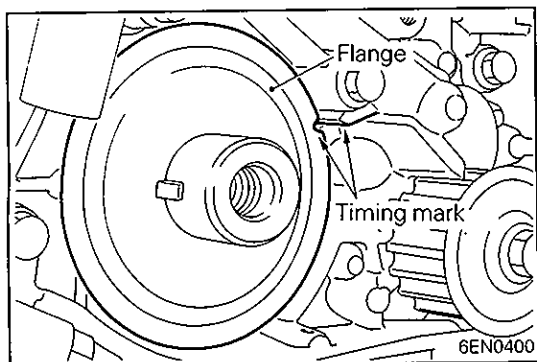

SERVICE POINTS OF INSTALLATION

◆A◆ INSTALLATION OF BEARING CAPS

(1) Install the crankshaft sprocket B or spacer and flange to an end of the crankshaft, and turn the crankshaft until the timing marks are lined up, setting No. 1 cylinder to the TDC.

(2) Set the camshafts so that their dowel pins are positioned at top.

(3) According to the identification mark stamped on top of each bearing cap, install the caps to the cylinder head. Only "L" or "R" is stamped on No. 1 bearing cap. Cap No. is stamped on No. 2 to No. 5 bearing caps. No. 6 bearing cap has no stamping.

Up to Nov. 1989

L: For intake camshaft side

R: For exhaust camshaft side

From to Dec. 1989

I: For intake camshaft side

E: For exhaust camshaft side

(4) Tighten the bearing caps in the order shown two to three times by torquing progressively.

Tighten to specification in the final sequence.

(5) Check to ensure that the rocker arm is held in position on the lash adjuster and valve stem end.

◆B◆ INSTALLATION OF CAMSHAFT OIL SEAL

(1) Install the special tool, Guide, on the camshaft.

(2) Apply oil to the oil seal and insert the oil seal along the Guide until it contacts the cylinder head.

(3) Using the special tool, Installer, press-fit the oil seal into the cylinder head.

NOTES

10. ROCKER ARMS AND ROCKER SHAFTS (SINGLE CAMSHAFT ENGINE)

DISASSEMBLY AND REASSEMBLY

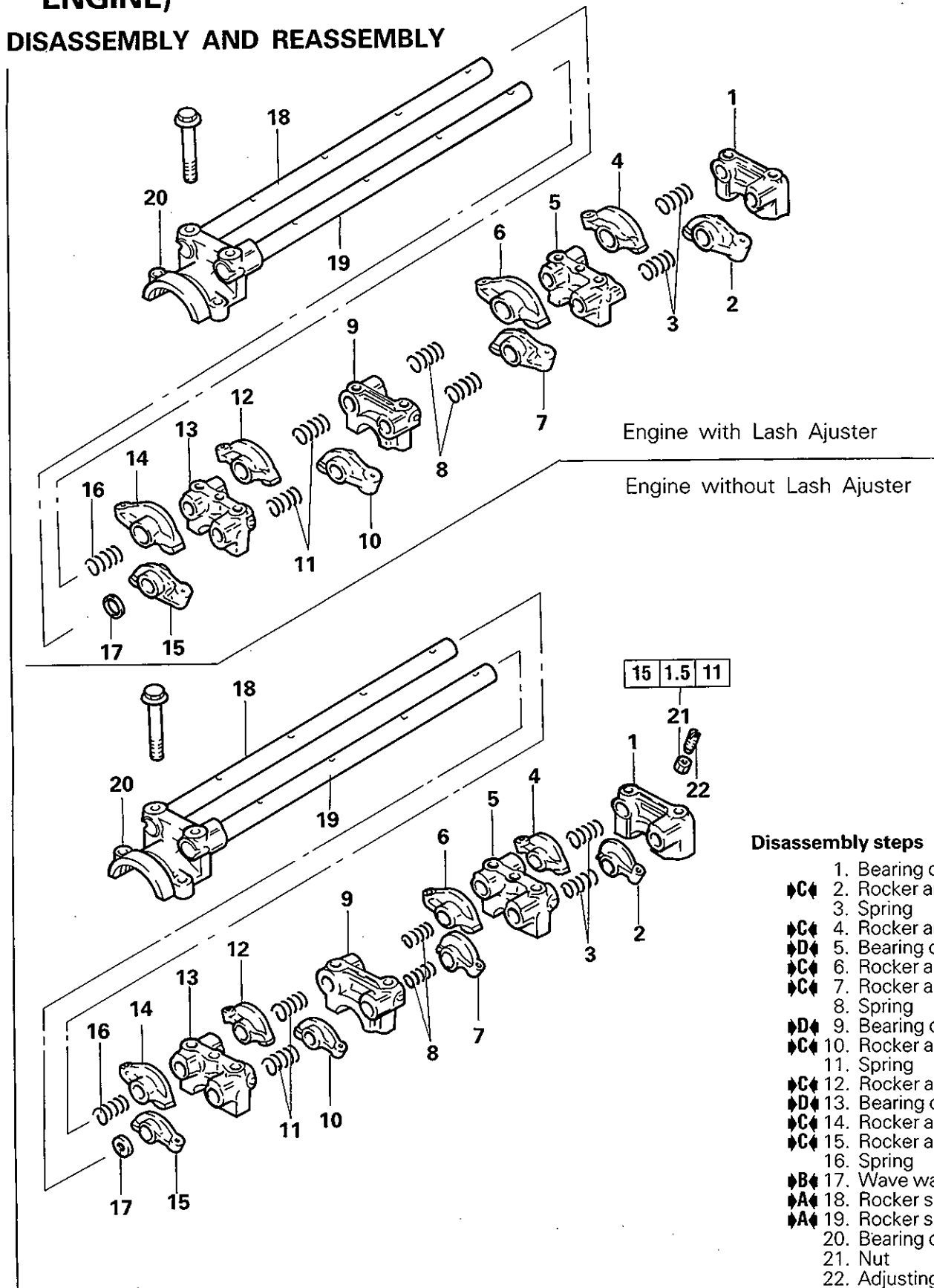

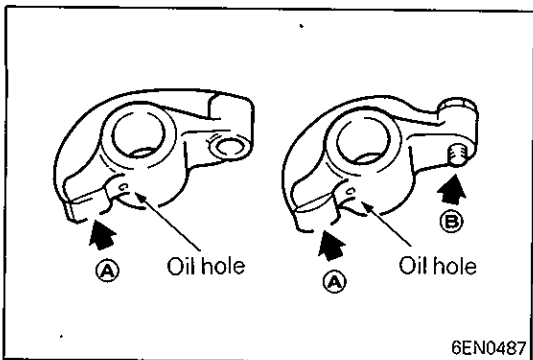

INSPECTION

ROCKER ARMS – SLIPPER TYPE

- (1) Check the surface (A) that contacts the cam lobe and replace if there is any dent, damage or seizure.
- (2) Check the adjusting screw, end (B) and replace if it is worn flat.
- (3) Check the bore and replace if there is any damage or seizure.
- (4) Check the oil hole and clean if clogged.

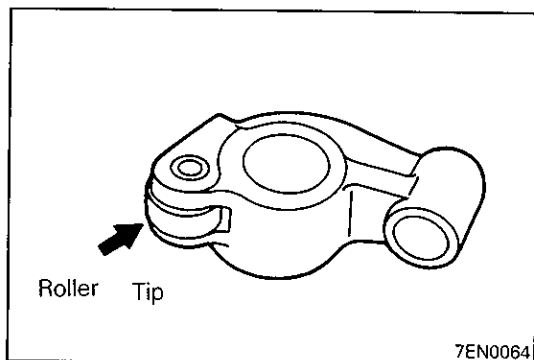

ROCKER ARM – ROLLER TYPE

- (1) Visually check the roller and replace if dent, damage, or seizure is evident.
- (2) Check the roller for smooth rotation. Replace if it binds or there is an excessive play.
- (3) Check the valve contact surface for possible damage or seizure and replace as necessary.

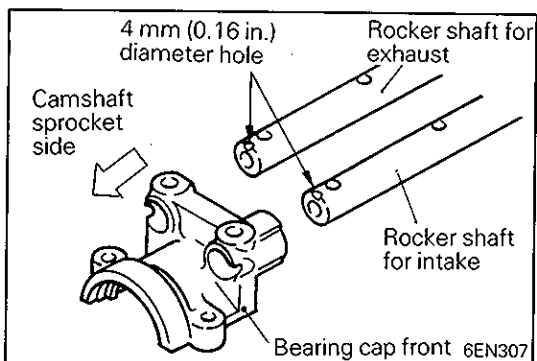

SERVICE POINTS OF REASSEMBLY

◆A◆ INSTALLATION OF ROCKER SHAFTS

- (1) Install rocker shafts with 4 mm (0.16 in.) diameter hole up and toward the front bearing cap.
- (2) The rocker shaft for intake valves is 13 mm (1/2 in.) longer than those for exhaust valves.

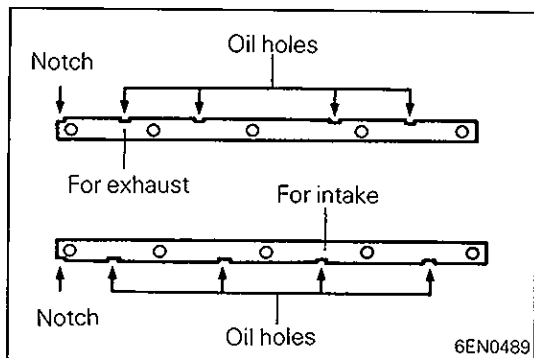

◆A◆ IDENTIFICATION OF ROCKER SHAFT (Reference)

- (1) The rocker shafts with oil holes and notches, as illustrated, are used for rocker arms with lash adjusters.

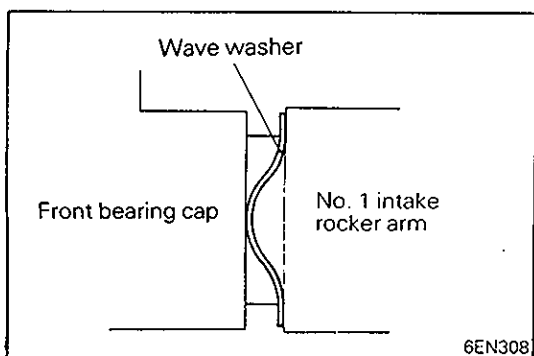

◆B◆ INSTALLATION OF WAVE WASHER

- (1) Install the wave washer in correct direction as shown.

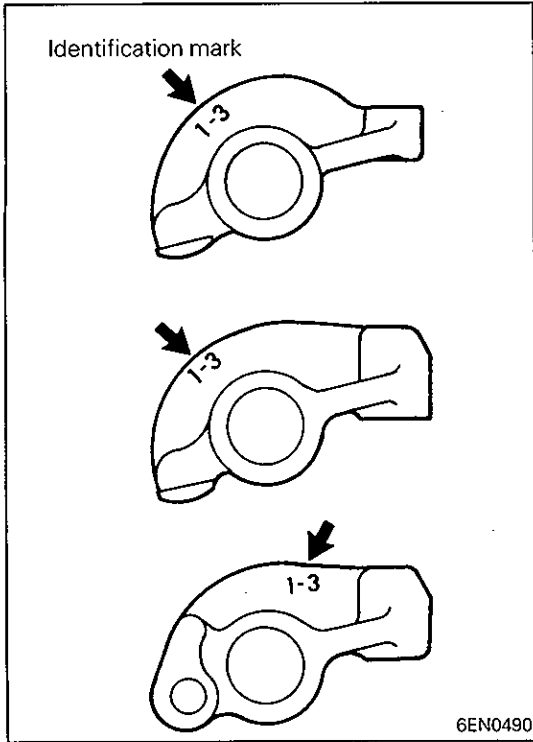

⇨C⇩ IDENTIFICATION OF ROCKER ARMS

Identification mark:

- 1-3 for No. 1 and 3 cylinders
- 2-4 for No. 2 and 4 cylinders

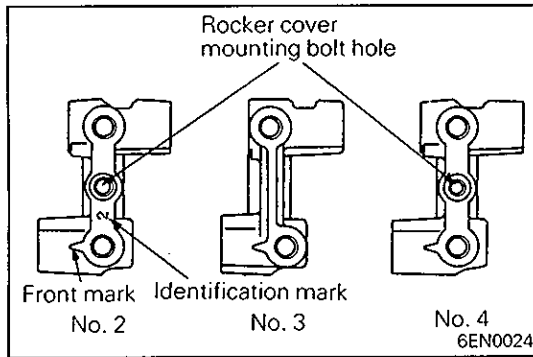

⇨D⇩ IDENTIFICATION OF CAMSHAFT BEARING CAPS.

NOTES

11. CYLINDER HEAD AND VALVES (SINGLE CAMSHAFT ENGINE) REMOVAL AND INSTALLATION

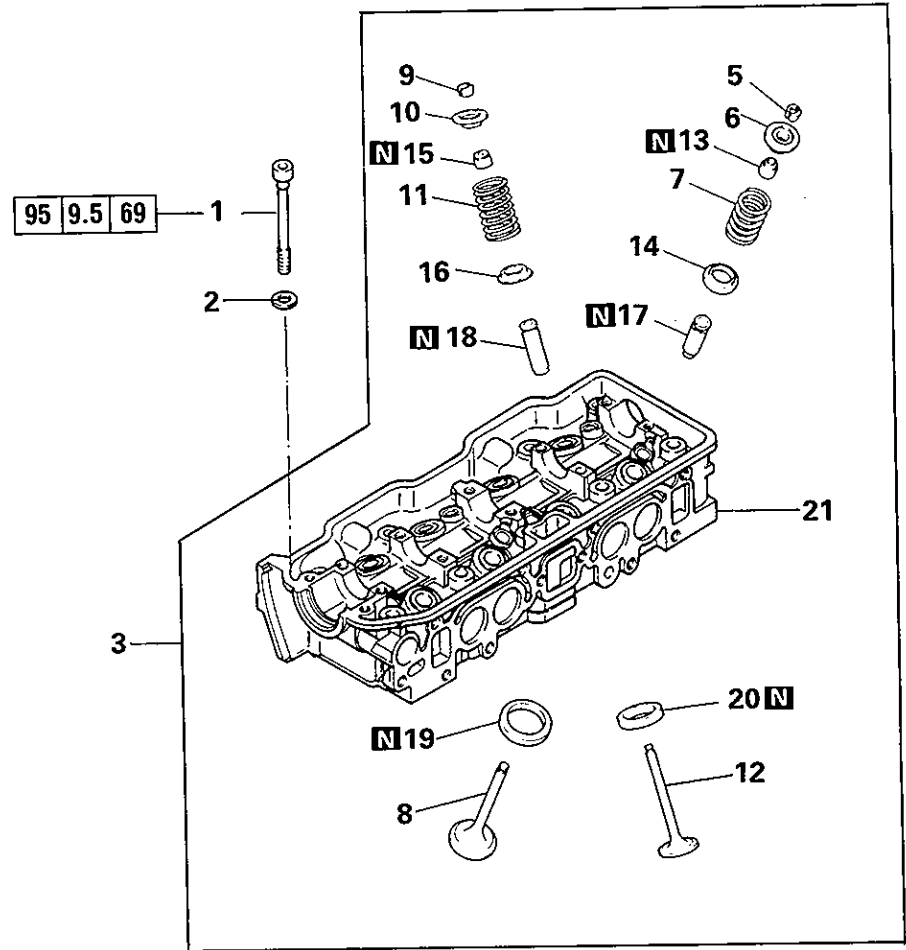

Removal steps

- ◊A◊ ◊D◊ 1. Cylinder head bolt
- 2. Washer
- 3. Cylinder head assembly
- ◊C◊ 4. Gasket
- 5. Retainer lock
- ◊B◊ 6. Valve spring retainer
- 7. Valve spring
- 8. Intake valve
- 9. Retainer lock
- ◊B◊ 10. Valve spring retainer
- ◊B◊ 11. Valve spring
- 12. Exhaust valve
- ◊B◊ ◊A◊ 13. Valve stem seal
- 14. Valve spring seat
- ◊B◊ ◊A◊ 15. Valve stem seal
- 16. Valve spring seat
- 17. Intake valve guide
- 18. Exhaust valve guide
- 19. Intake valve seat
- 20. Exhaust valve seat
- 21. Cylinder head

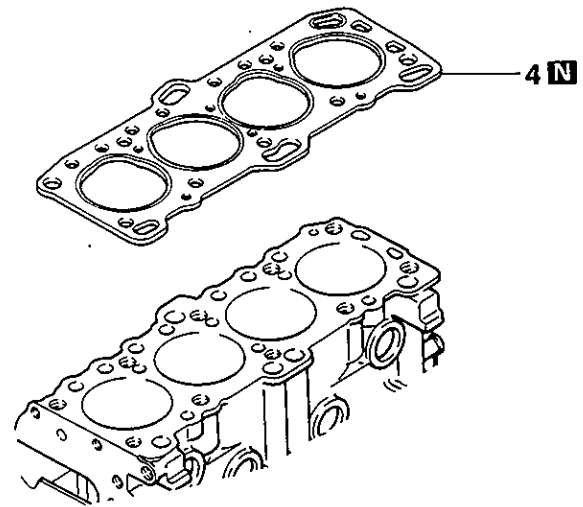

11A-11-2 ENGINE – Cylinder Head and Valves (Single Camshaft Engine)

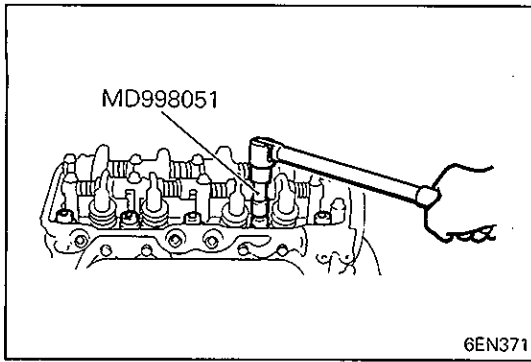

SERVICE POINTS OF REMOVAL

PRECAUTION FOR REMOVED PARTS

- (1) Keep removed parts in order according to the cylinder number and intake/exhaust.

◇A◇ REMOVAL OF CYLINDER HEAD BOLTS

- (1) Using the special tool, loosen the cylinder head bolts. Loosen evenly, little by little.

◇B◇ REMOVAL OF VALVE STEM SEAL

- (1) Do not reuse valve stem seal.

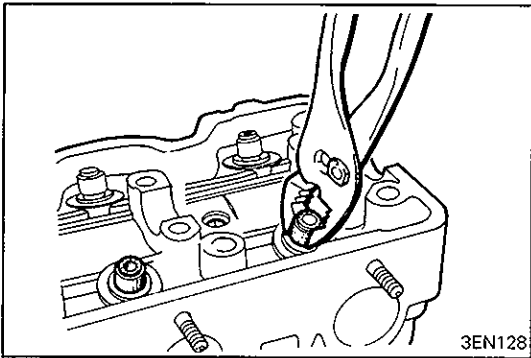

INSPECTION

CYLINDER HEAD

- (1) Check the cylinder head, before cleaning, for water leaks, gas leaks, damage, and cracks.
- (2) Remove oil, scale, sealing compound, and carbon deposits completely. After cleaning oil passages, apply compressed air to ensure that the passages are not clogged.

- (3) Check the cylinder head gasket surface for flatness by using a straightedge in the directions of A through G shown in illustration.

Standard value: 0.05 mm (0.0020 in.)

Limit: 0.2 mm (0.008 in.)

- (4) If the service limit is exceeded, correct to meet specification.

Grinding limit: 0.2 mm (0.008 in.)

Caution

- The total thickness of the stock allowed to be removed from cylinder head and mating cylinder block is 0.2 mm (0.008 in.) in thickness.

Cylinder head height (Specification when new):

89.9 – 90.1 mm (3.539 – 3.547 in.)

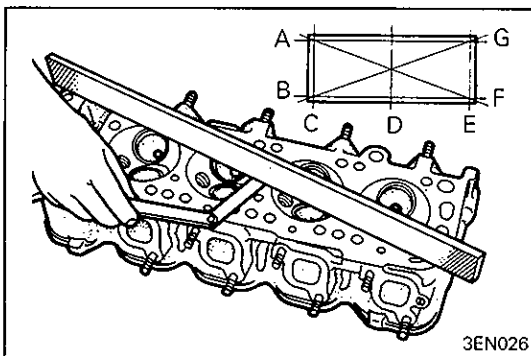

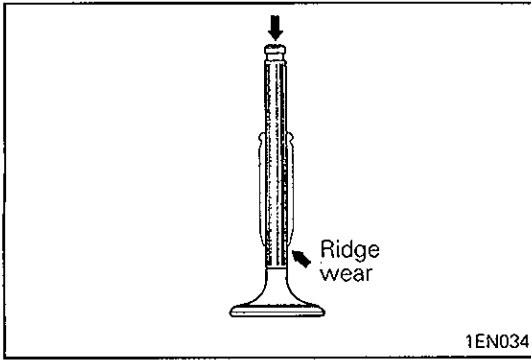

VALVE

- (1) If the valve stem is worn (ridge wear) or otherwise damaged, replace. Also replace the valve if the stem end (that contacts to the rocker arm adjusting screw) has a dent.

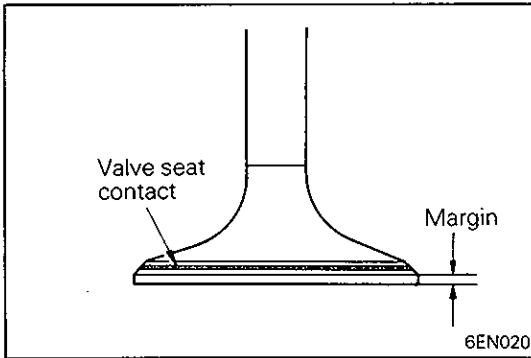

- (2) Check the valve face for correct contact. If incorrect, reface using valve refacer. Valve seat contact should be maintained uniform at the center of valve face.
- (3) If the margin exceeds the service limit, replace the valve.

Standard value:

1.2 mm (0.047 in.)	Intake
2.0 mm (0.079 in.)	Exhaust

Limit:

0.7 mm (0.028 in.)	Intake
1.5 mm (0.059 in.)	Exhaust

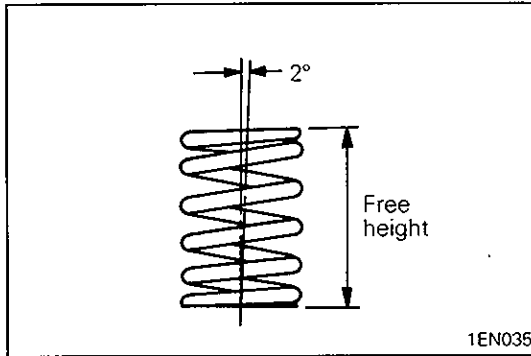

VALVE SPRING

- (1) Measure the free height of spring and, if it is smaller than the limit, replace.

Identification color: Green

Standard value: 47.5 mm (1.869 in.)

Limit: 46.5 mm (1.829 in.)

Identification color: White

Standard value: 49.8 mm (1.961 in.)

Limit: 48.8 mm (1.922 in.)

- (2) Measure the squareness of the spring and, if the limit is exceeded, replace.

Standard value: 2° or less

Limit: Max. 4°

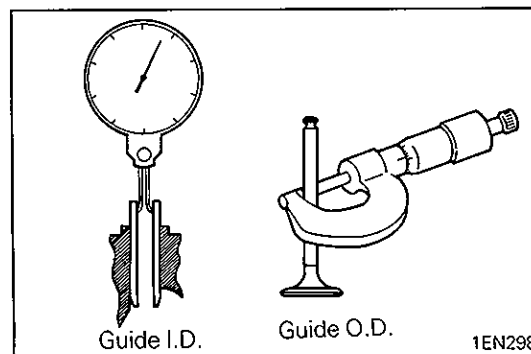

VALVE GUIDE

- (1) Measure the clearance between the valve guide and valve stem. If the limit is exceeded, replace the valve guide or valve, or both.

Standard value:

0.02 – 0.06 mm (0.0008 – 0.0024 in.)	Intake
0.05 – 0.09 mm (0.0020 – 0.0035 in.)	Exhaust

Limit:

0.10 mm (0.004 in.)	Intake
0.15 mm (0.006 in.)	Exhaust

11A-11-4 ENGINE – Cylinder Head and Valves (Single Camshaft Engine)

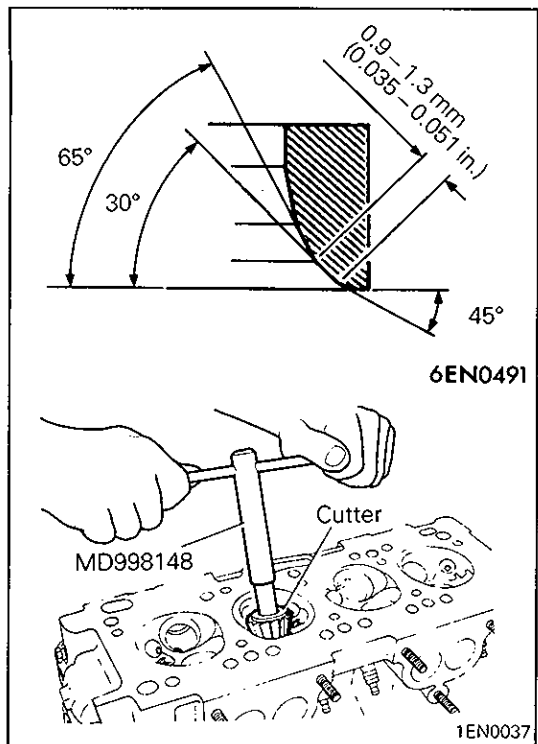

VALVE SEAT RECONDITIONING PROCEDURE

- (1) Before correcting the valve seat, check for clearance between the valve guide and valve and, if necessary, replace the valve guide.
- (2) Using the special tool or seat grinder, correct to obtain the specified seat width and angle.

Cutter angle	Tool number	
	Intake	Exhaust
45°	MD998159	MD998158
65°	MD998165	MD998165
30°	MD998175	MD998173

- (3) After correction, valve and valve seat should be lapped with a lapping compound.

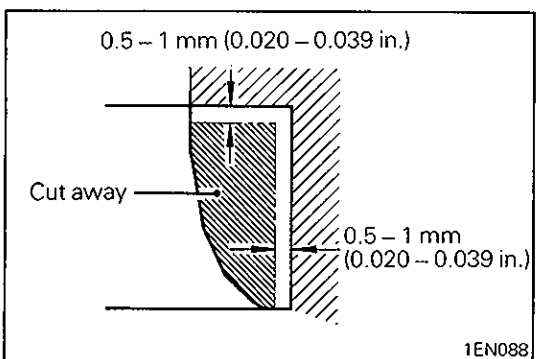

VALVE SEAT REPLACEMENT PROCEDURE

- (1) Cut the valve seat to be replaced from the inside to thin the wall thickness. Then, remove the valve seat.

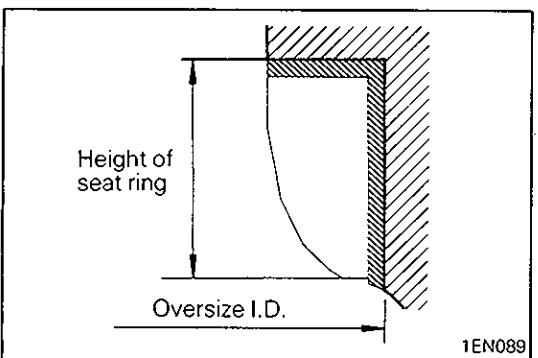

- (2) Rebore the valve seat hole in cylinder head to a selected oversize valve seat diameter.

Intake valve seat hole diameter

4G63

0.30 O.S.: 44.30 – 44.33 mm
(1.7441 – 1.7453 in.)

0.60 O.S.: 44.60 – 44.63 mm
(1.7559 – 1.7571 in.)

4G64

0.30 O.S.: 47.30 – 47.33 mm
(1.8622 – 1.8634 in.)

0.60 O.S.: 47.60 – 47.63 mm
(1.8740 – 1.8752 in.)

Exhaust valve seat hole diameter

4G63

0.30 O.S.: 38.30 – 38.33 mm
(1.5079 – 1.5091 in.)

0.60 O.S.: 38.60 – 38.63 mm
(1.5197 – 1.5209 in.)

4G64

0.30 O.S.: 40.30 – 40.33 mm
(1.5866 – 1.5878 in.)

0.60 O.S.: 40.60 – 40.63 mm
(1.5984 – 1.5996 in.)

- (3) Before fitting the valve seat, either heat the cylinder head up to approximately 250°C (482°F) or cool the valve seat in liquid nitrogen, to prevent the cylinder head bore from galling.
- (4) Using valve seat cutter, correct the valve seat to the specified width and angle.
See "VALVE SEAT RECONDITIONING PROCEDURE".

VALVE GUIDE REPLACEMENT PROCEDURE

- (1) Using the special tool and a press, remove the valve guide toward cylinder head gasket surface.
- (2) Rebore valve guide hole to the new oversize valve guide outside diameter.

Valve guide hole diameter

0.05 O.S.: 13.05 – 13.07 mm
(0.5138 – 0.5146 in.)

0.25 O.S.: 13.25 – 13.27 mm
(0.5217 – 0.5224 in.)

0.50 O.S.: 13.50 – 13.52 mm
(0.5315 – 0.5323 in.)

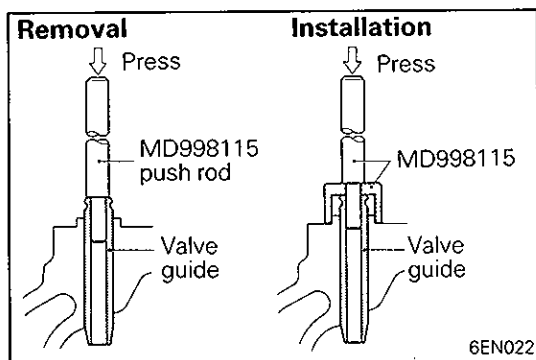

NOTE

Do not install a valve guide of the same size again.

- (3) Using the special tool, press-fit the valve guide, working from the cylinder head top surface.
- (4) After installing valve guides, insert new valves in them to check for sliding condition.
- (5) When valve guides have been replaced, check for valve contact and correct valve seats as necessary.

SERVICE POINTS OF INSTALLATION

◆A◆ INSTALLATION OF VALVE STEM SEAL

- (1) Install the valve spring seat.

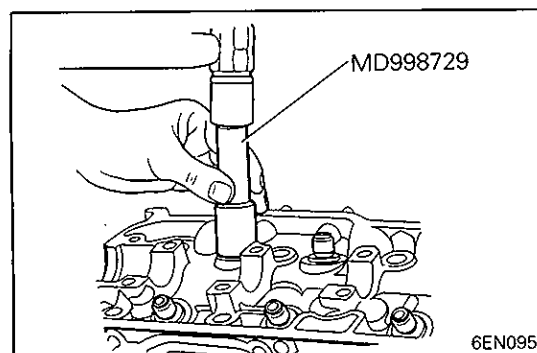
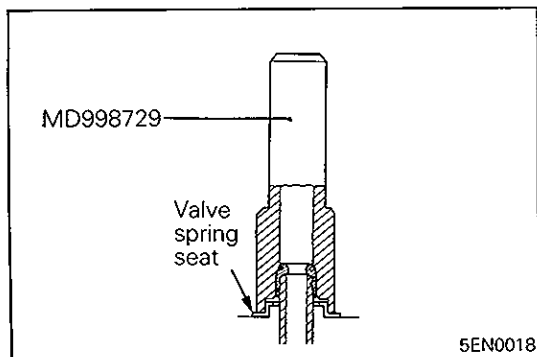

- (2) Using the special tool, install a new stem seal to the valve guide.

Caution

- Do not reuse the valve stem seal.

11A-11-6 ENGINE – Cylinder Head and Valves (Single Camshaft Engine)

▶B▶ INSTALLATION OF VALVE SPRINGS

- (1) Direct the valve spring end with identification color end toward the spring retainer.

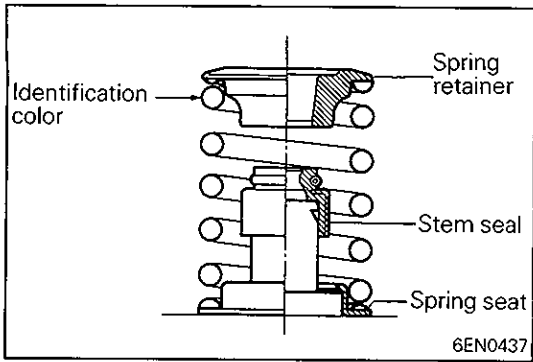

▶C▶ IDENTIFICATION OF CYLINDER HEAD GASKET

Identification mark: 63 4G63
64 4G64

Caution

- Do not apply sealant to cylinder head gasket.

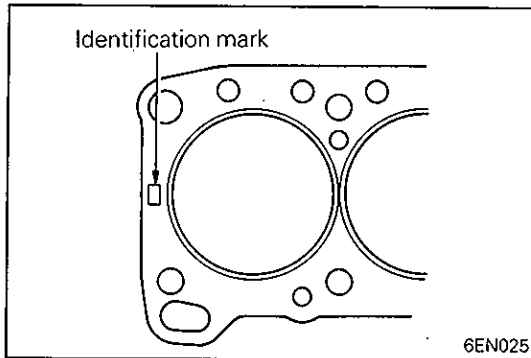

▶D▶ INSTALLATION OF CYLINDER HEAD BOLT

- (1) Tighten the cylinder head bolts in the sequence shown. Each bolt should be tightened in two to three steps, torquing progressively. Tighten to specified torque in the final sequence.

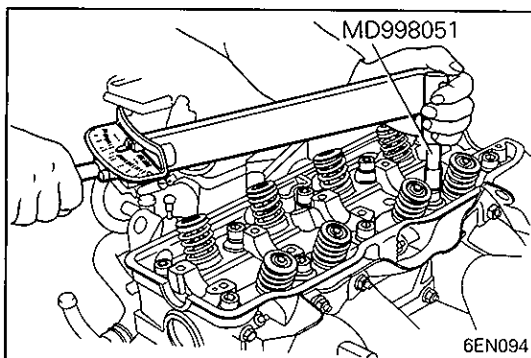
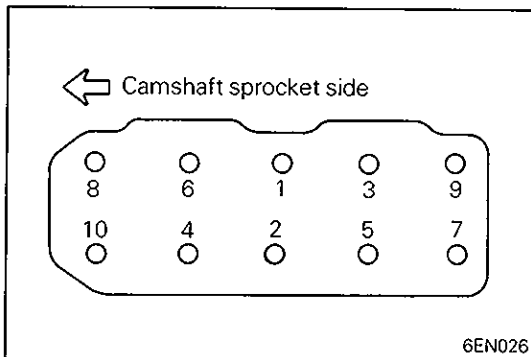

12. CYLINDER HEAD AND VALVES (DOUBLE CAMSHAFT ENGINE) REMOVAL AND INSTALLATION

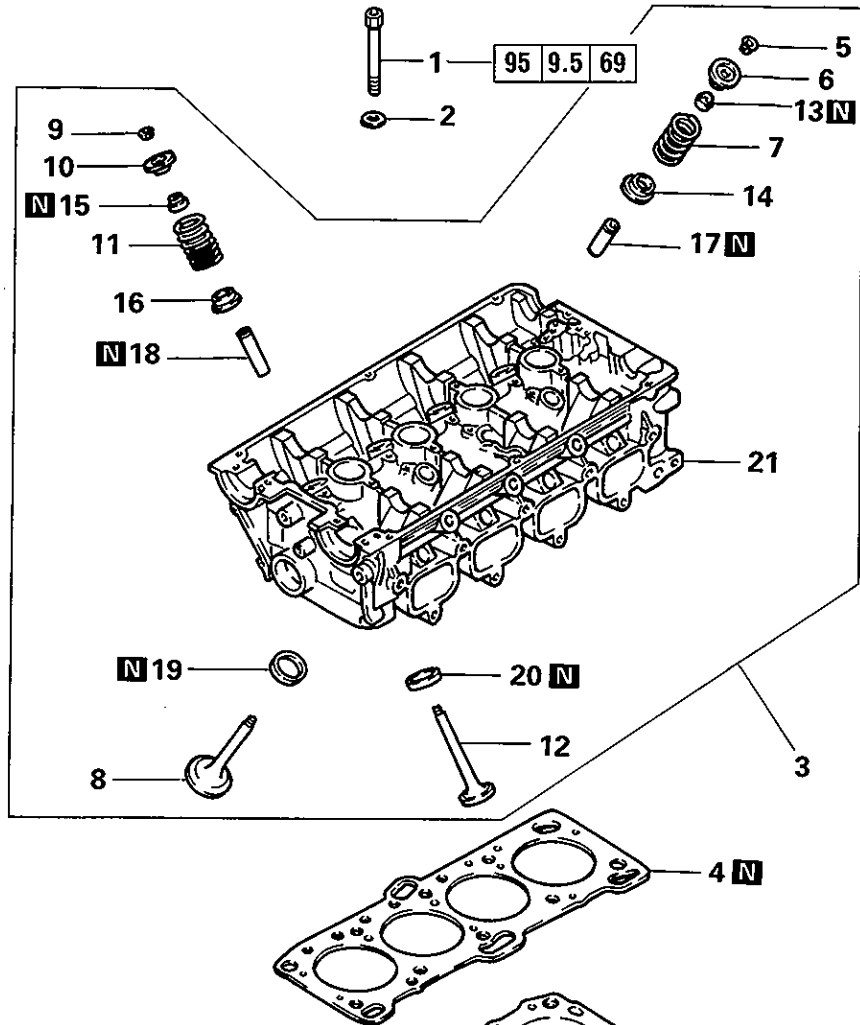

Removal steps

- ◊A◊ 1. Cylinder head bolt
- 2. Washer
- 3. Cylinder head assembly
- ◊D◊ 4. Gasket
- ◊B◊ ◊C◊ 5. Retainer lock
- ◊B◊ 6. Valve spring retainer
- ◊B◊ 7. Valve spring
- ◊B◊ ◊C◊ 8. Intake valve
- ◊B◊ ◊C◊ 9. Retainer lock
- ◊B◊ ◊C◊ 10. Valve spring retainer
- ◊B◊ 11. Valve spring
- ◊C◊ ◊A◊ 12. Exhaust valve
- ◊C◊ ◊A◊ 13. Valve stem seal
- ◊C◊ ◊A◊ 14. Valve spring seat
- ◊C◊ ◊A◊ 15. Valve stem seal
- ◊C◊ ◊A◊ 16. Valve spring seat
- 17. Intake valve guide
- 18. Exhaust valve guide
- 19. Intake valve seat
- 20. Exhaust valve seat
- 21. Cylinder head

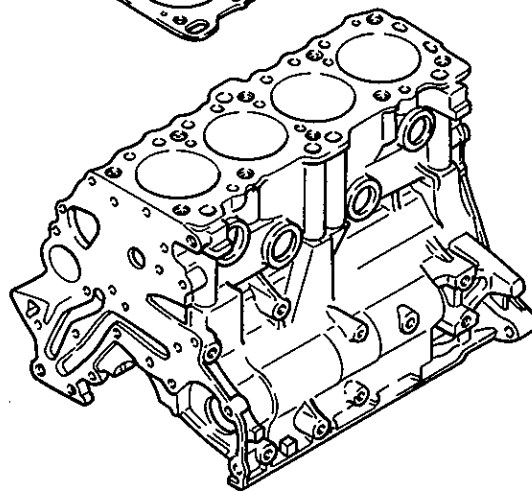

11A-12-2 ENGINE – Cylinder Head and Valves (Double Camshaft Engine)

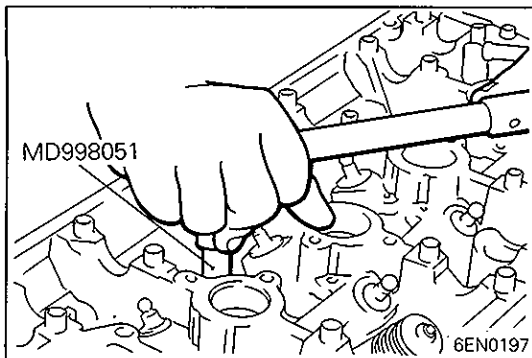

SERVICE POINTS OF REMOVAL

PRECAUTION FOR REMOVED PARTS

- (1) Keep removed parts in order according to the cylinder number and intake/exhaust.

◊A◊ REMOVAL OF CYLINDER HEAD BOLTS

- (1) Using the special tool, loosen the cylinder head bolts. Loosen evenly, little by little.

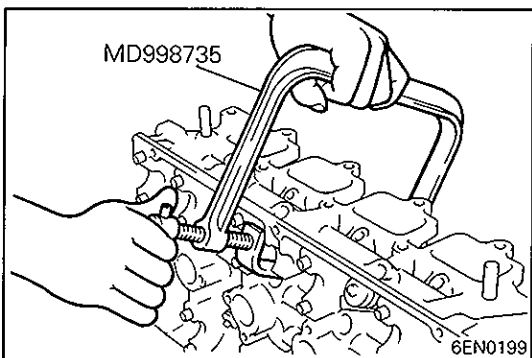

◊B◊ REMOVAL OF RETAINER LOCKS

- (1) Using the special tool, compress the spring.
- (2) Remove the retainer locks. Keep removed parts in order according to the cylinder number and intake/exhaust.

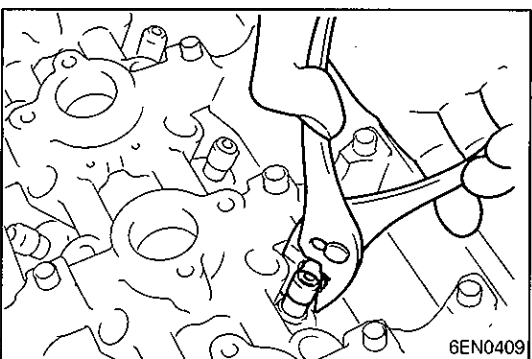

◊C◊ REMOVAL OF VALVE STEM SEALS

- (1) Do not reuse the stem seals.

INSPECTION

- (1) Only features differing from the single camshaft engine are described in the following. (Refer to Pages 11A-11-2 and 3.)

CYLINDER HEAD

Cylinder head height (when new):

131.9 – 132.1 mm (5.193 – 5.201 in.)

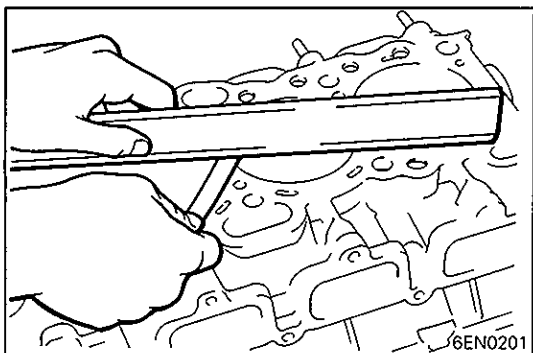

VALVE

Margin:

1.0 mm (0.039 in.) Intake
 1.5 mm (0.059 in.) Exhaust

Limit:

0.7 mm (0.028 in.) Intake
 1.0 mm (0.039 in.) Exhaust

VALVE SPRING

Free height: 48.3 mm (1.902 in.)

Limit: 47.4 mm (1.866 in.)

Squareness: 1.5° or less

Limit: Max. 4°

VALVE GUIDE

Valve guide to valve stem clearance:

0.02 – 0.05 mm (0.0008 – 0.0020 in.) Intake
 0.05 – 0.09 mm (0.0020 – 0.0035 in.) Exhaust

Limit:

0.10 mm (0.004 in.) Intake
 0.15 mm (0.006 in.) Exhaust

VALVE SEAT RECONDITIONING PROCEDURE

(1) Refer to Page 11A-11-4, noting that the only difference is in the special tool (Cutter).

Valve Seat Cutters

Cutter angle	Tool number	
	Intake	Exhaust
45°	MD998157	MD998156
65°	MD998614	MD998614
30°	MD998172	MD998171

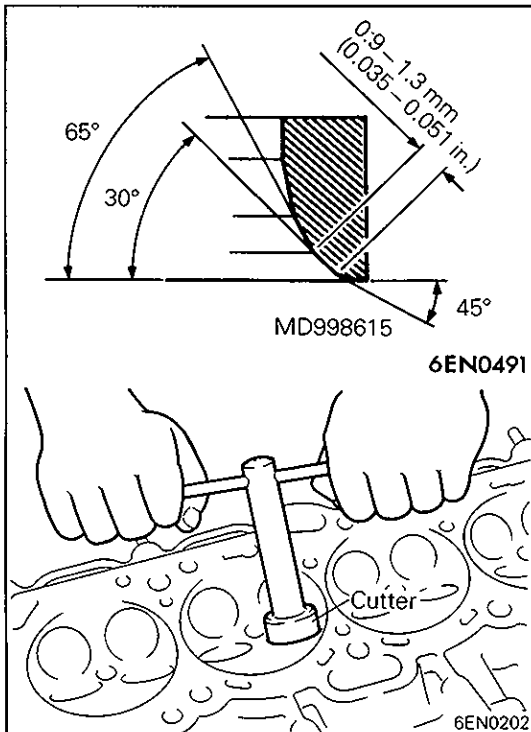

VALVE SEAT REPLACEMENT PROCEDURE

- (1) Refer to Page 11A-11-4 noting that the only difference is in the reboring size.

Intake valve seat hole diameter

0.3 O.S. 35.30 – 35.33 mm (1.3898 – 1.3909 in.)

0.6 O.S. 35.60 – 35.63 mm (1.4016 – 1.4028 in.)

Exhaust valve seat hole diameter

0.3 O.S. 33.30 – 33.33 mm (1.3110 – 1.3122 in.)

0.6 O.S. 33.60 – 33.63 mm (1.3228 – 1.3240 in.)

VALVE GUIDE REPLACEMENT PROCEDURE

- (1) Refer to Page 11A-11-5, noting that there are differences in the diameter of the valve guide hole as well as in the guide's installed height.

Valve Guide Hole Diameter

0.05 O.S. 12.05 – 12.07 mm (0.4744 – 0.4752 in.)

0.25 O.S. 12.25 – 12.27 mm (0.4823 – 0.4831 in.)

0.50 O.S. 12.50 – 12.52 mm (0.4921 – 0.4929 in.)

SERVICE POINTS OF INSTALLATION

▶▶ INSTALLATION OF VALVE STEM SEAL

- (1) Install the valve spring seat.
- (2) Using the special tool, install a new stem seal to the valve guide.

Caution

- Do not reuse the valve stem seal.

▶▶ INSTALLATION OF VALVE SPRINGS

- (1) Install the valve spring so that its end with identification color is positioned on the rocker arm end.

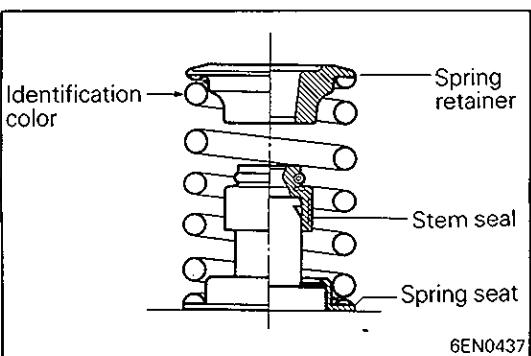
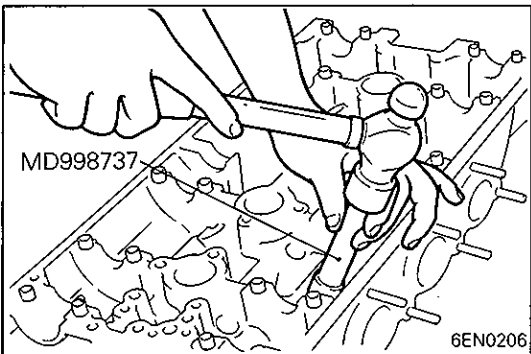
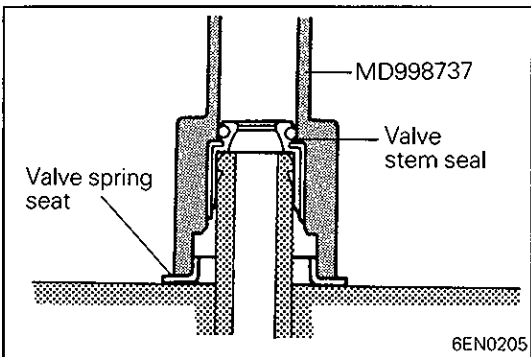
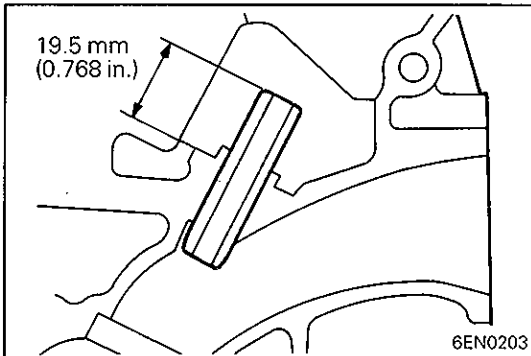

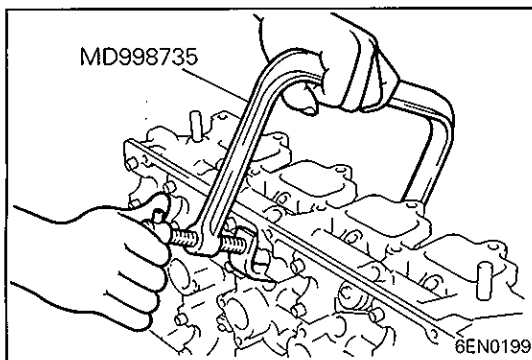

▶C◀ INSTALLATION OF RETAINER LOCKS

- (1) Using the special tool, compress the valve spring and insert the retainer lock into position.

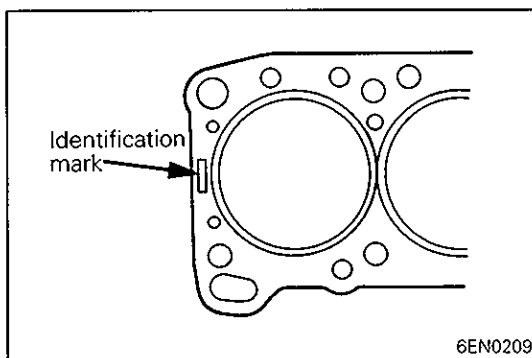

▶D◀ IDENTIFICATION OF CYLINDER HEAD GASKET

Identification mark:

16	4G61, 4G67
20	4G63

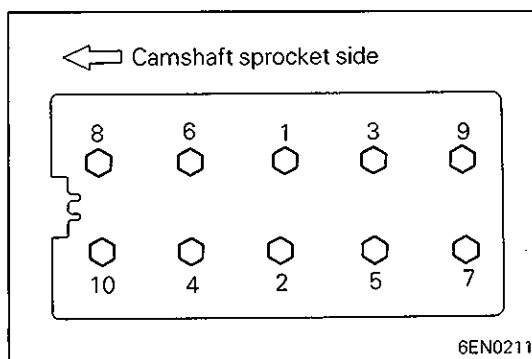

▶E◀ INSTALLATION OF CYLINDER HEAD BOLTS

- (1) Tighten the cylinder head bolts in the sequence shown. Each bolt should be tightened in two to three steps, torquing progressively. Tighten to specified torque in the final sequence.

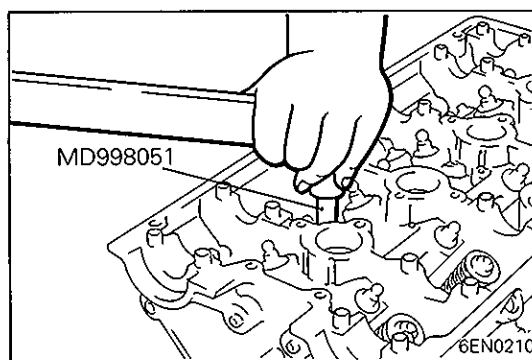

NOTES

13. FRONT CASE, SILENT SHAFT AND OIL PAN REMOVAL AND INSTALLATION

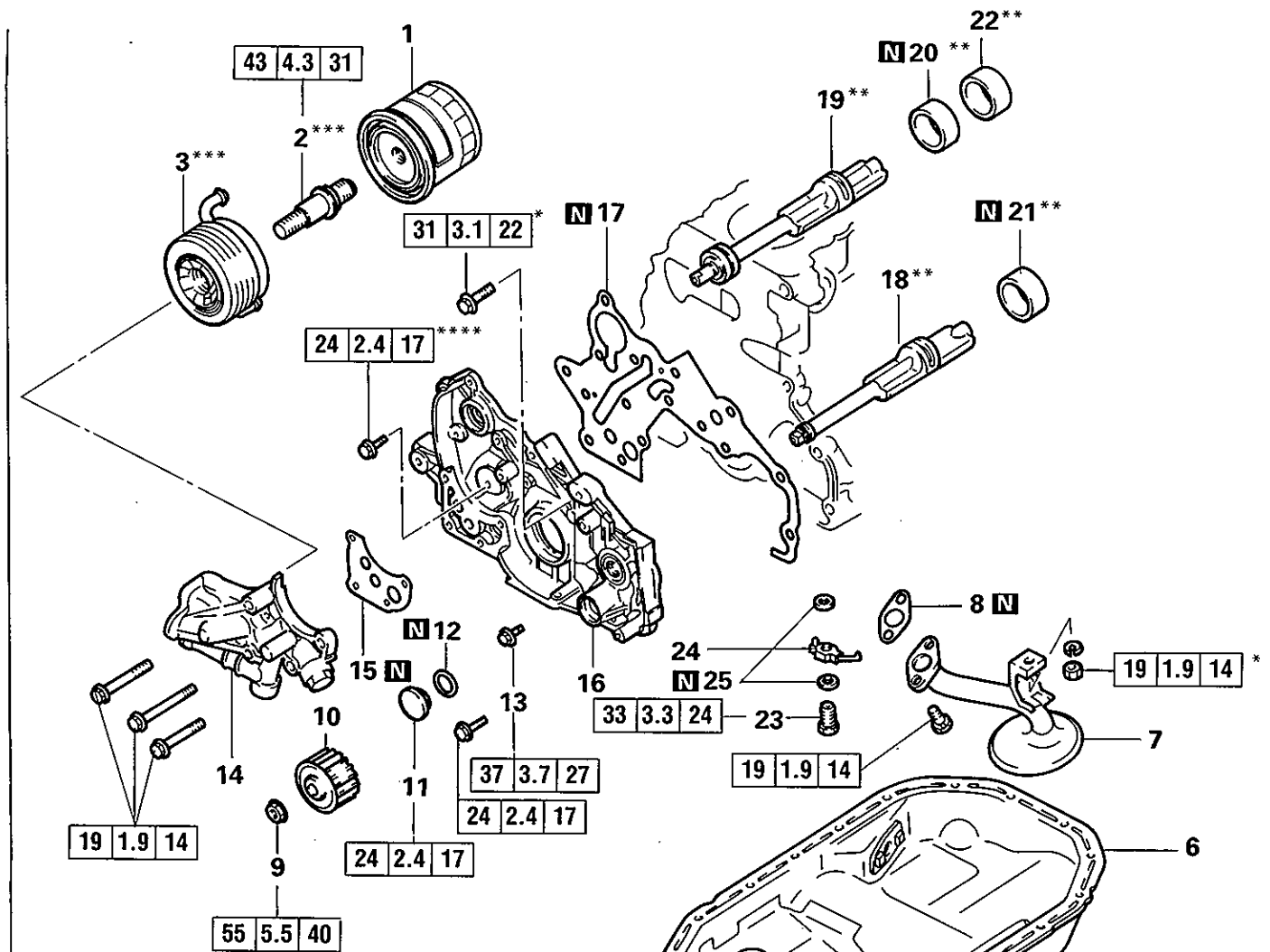

Removal steps

1. Oil filter
2. Oil cooler bolt***
3. Oil cooler***
4. Drain plug
5. Drain plug gasket
6. Oil pan
7. Oil screen
8. Oil screen gasket
9. Flange nut**
10. Oil pump sprocket**
11. Plug**
12. O-ring**
13. Flange bolt**
14. Oil filter bracket
15. Oil filter bracket gasket
16. Front case
17. Front case gasket
18. Silent shaft, left**
19. Silent shaft, right**
20. Silent shaft, front bearing**
21. Silent shaft, rear bearing, left**
22. Silent shaft, rear bearing, right**

23. Check valve
24. Oil jet
25. Gasket

NOTE

- * : Double camshaft engine
- ** : Engine with silent shafts
- *** : Engine with turbocharger
- **** : Engine without silent shafts
- ***** : Engine with air-cooling type oil cooler

DISASSEMBLY AND REASSEMBLY

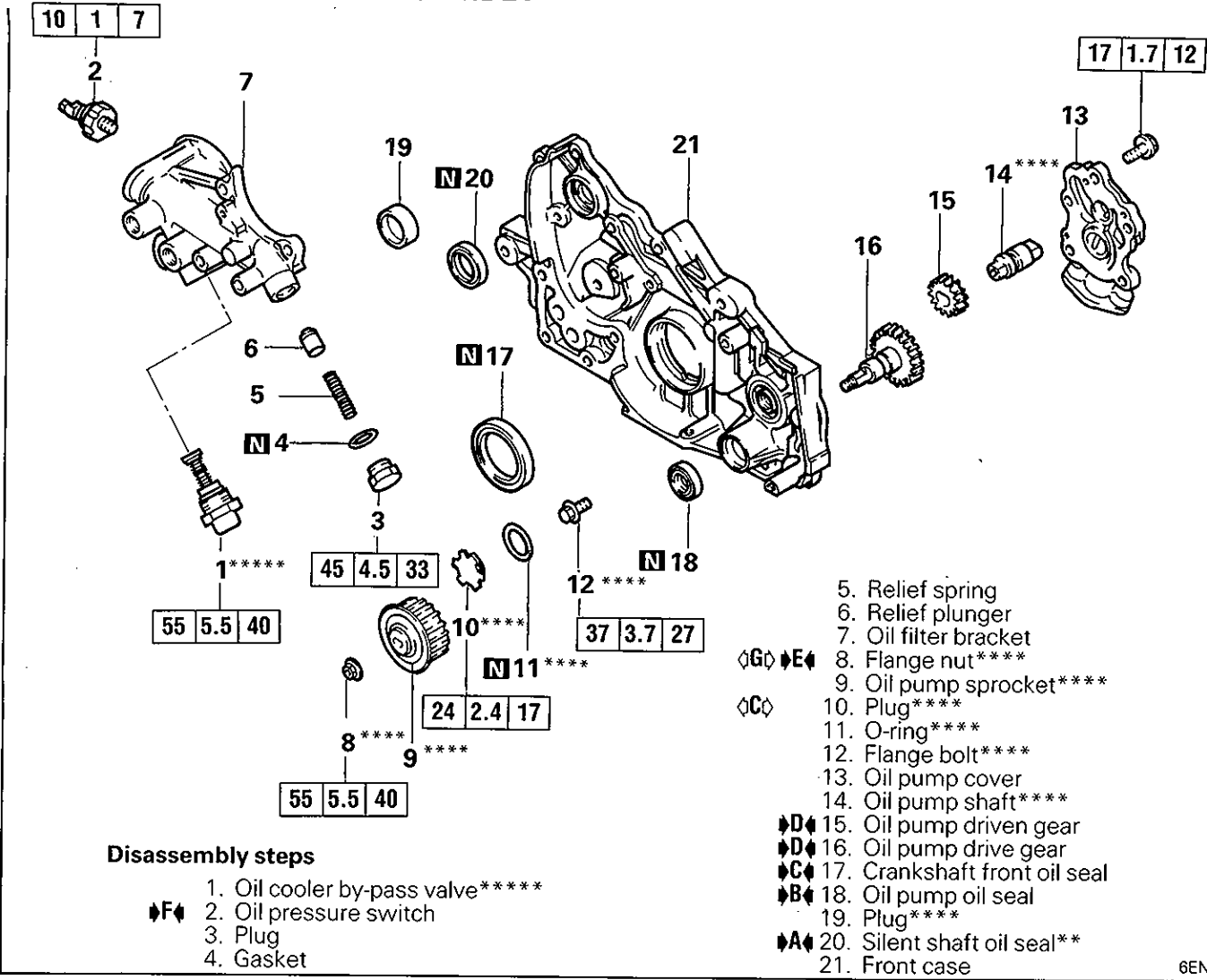

6EN0493

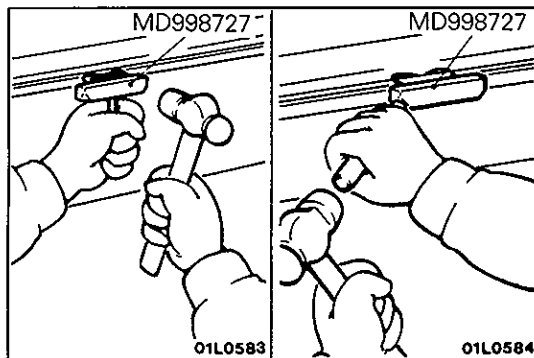
**SERVICE POINTS OF REMOVAL****◁A▷ REMOVAL OF OIL PAN**

- (1) Remove the all oil pan bolts.
- (2) Drive in the special tool between the cylinder block and oil pan.

NOTE

Never use a screwdriver or chisel, instead of the special tool, as a deformed oil pan flange will result, resulting in oil leakage.

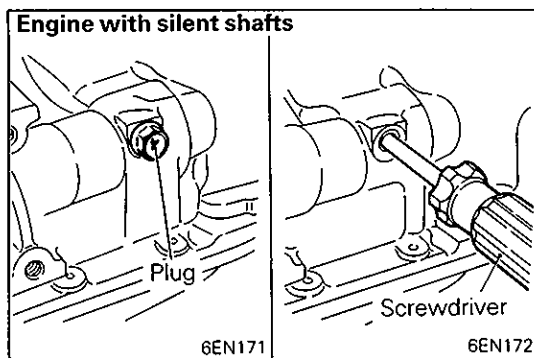
**◁B▷ REMOVAL OF FLANGE NUT (ENGINE WITH SILENT SHAFTS)**

- (1) Remove the plug on the side of cylinder block.
- (2) Insert a Phillips screwdriver [shank diameter 8 mm (0.32 in.)] into the plug hole to lock the silent shaft.
- (3) Loosen the oil pump sprocket flange nut.

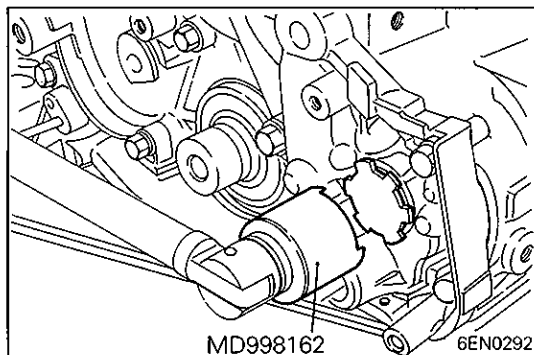
**◁C▷ REMOVAL OF PLUG**

- (1) If the plug is too tight, hit the plug head with a hammer two to three times, and the plug will be easily loosened.

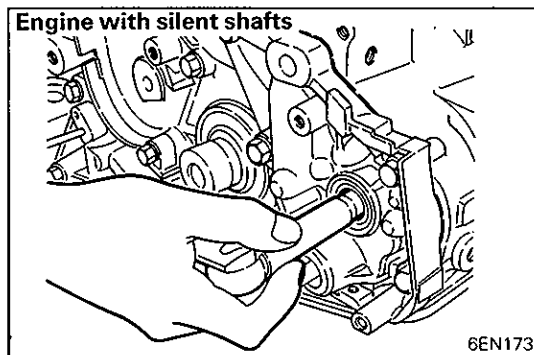
**◁D▷ REMOVAL OF FLANGE BOLT (ENGINE WITH SILENT SHAFTS)**

- (1) Referring to ◁B▷ (2), lock the silent shaft.
- (2) Loosen the flange bolt.

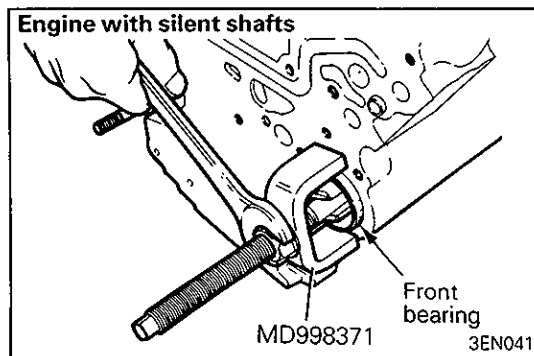
**◁E▷ REMOVAL OF SILENT SHAFT FRONT BEARING (ENGINE WITH SILENT SHAFTS)**

- (1) Using the special tool, remove the right silent shaft bearing from the cylinder block.

NOTE

Be sure to remove the front bearing first. If it has not been removed, the Rear Bearing Puller cannot be used.

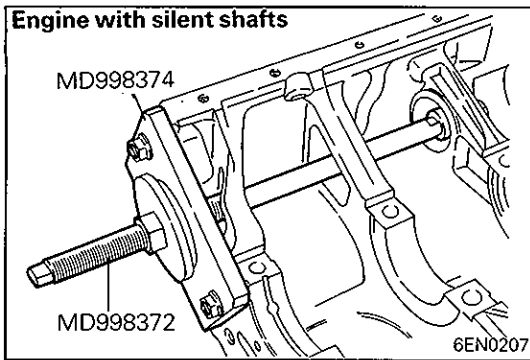

◁F▷ REMOVAL OF REAR BEARING (ENGINE WITH SILENT SHAFTS)

- (1) Using the special tool, remove the rear bearings from the cylinder block.
- (2) To remove the left rear bearing, install the special tool, Silent Shaft Bearing Installer Stopper, to the front of the cylinder block, then remove the bearing using the special tool, Silent Shaft Bearing Puller.

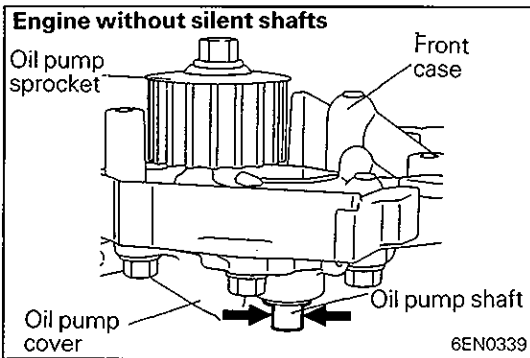

◁G▷ REMOVAL OF FLANGE NUT (ENGINE WITHOUT SILENT SHAFTS)

- (1) Clamp the oil pump shaft end with vise.

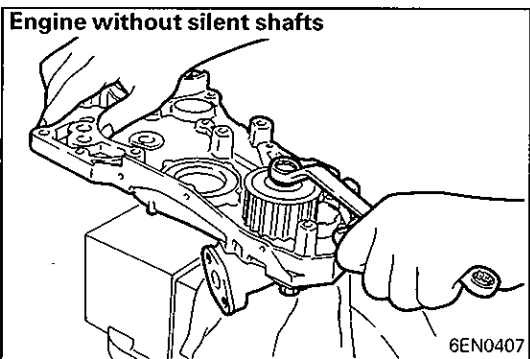

- (2) Remove the oil pump sprocket nut.

INSPECTION

FRONT CASE

- (1) Check oil holes for clogging and clean if necessary.
- (2) Check left silent shaft front bearing section for wear, damage and seizure. If there is anything wrong with the section, replace the front case.
- (3) Check the front case for cracks and other damage. Replace cracked or damaged front case.

OIL SEAL

- (1) Check the oil seal lip for wear and damage. Replace oil seal if necessary.
- (2) Check the oil seal lip for deterioration. Replace oil seal if necessary.

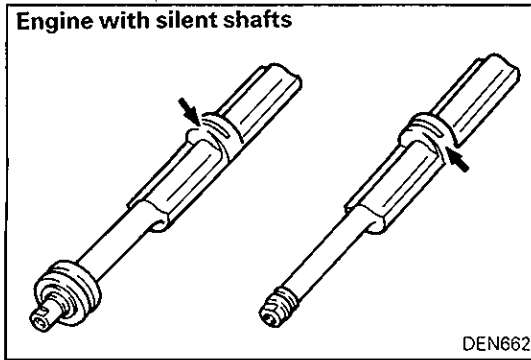

SILENT SHAFT (ENGINE WITH SILENT SHAFTS)

- (1) Check oil holes for clogging.
- (2) Check journal for seizure, damage and contact with bearing. If there is anything wrong with the journal, replace silent shaft, bearing or front case assembly.
- (3) Check the silent shaft oil clearance. If the clearance is excessively due to wear, replace the silent shaft bearing, silent shaft or front case assembly.

Standard value:

Front

0.03 – 0.06 mm (0.0012 – 0.0024 in.) **Right**

0.02 – 0.05 mm (0.0008 – 0.0020 in.) **Left**

Rear

0.05 – 0.09 mm (0.0020 – 0.0036 in.) **Right**

0.05 – 0.09 mm (0.0020 – 0.0036 in.) **Left**

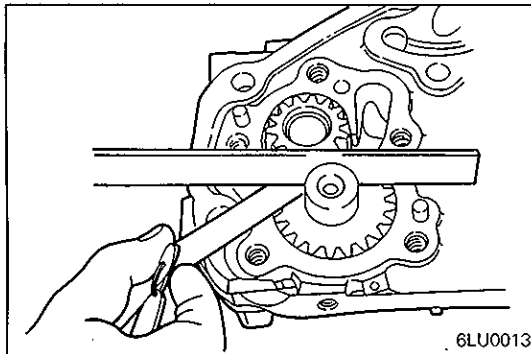

OIL PUMP

- (1) Assemble the oil pump gear to the front case and rotate it to ensure smooth rotation with no looseness.
- (2) Ensure that there is no ridge wear on the contact surface between the front case and the gear surface of the oil pump cover.
- (3) Check the side clearance

Standard value:

0.08 – 0.14 mm (0.0031 – 0.0055 in.) **Drive gear**

0.06 – 0.12 mm (0.0024 – 0.0047 in.) **Driven gear**

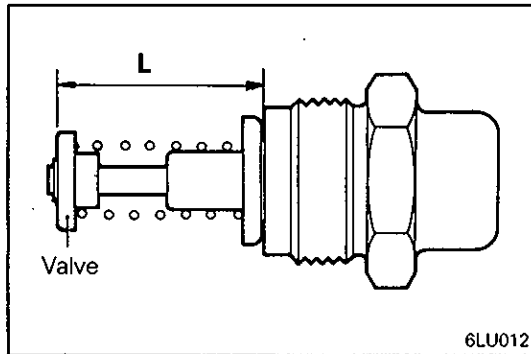

OIL COOLER BYPASS VALVE (ENGINE WITH AIR COOLING TYPE OIL COOLER)

- (1) Make sure that the valve moves smoothly.
- (2) Ensure that the dimension (L) measures the standard value under normal temperature and humidity.

Standard value (L): 34.5 (0.358 in.)

- (3) The dimension must be the standard value when measured after the valve has been dipped in 100°C (212°F) oil.

Standard value (L): 40 mm (1.57 in.) or more

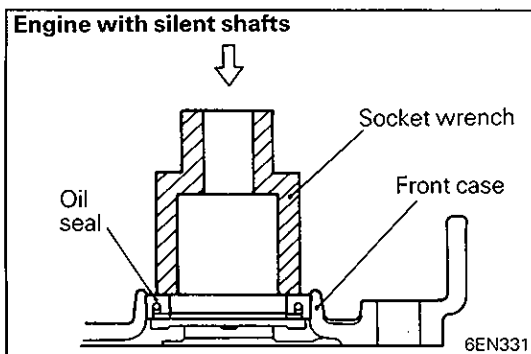

SERVICE POINTS OF INSTALLATION

◆A◆ INSTALLATION OF SILENT SHAFT OIL SEAL (ENGINE WITH SILENT SHAFTS)

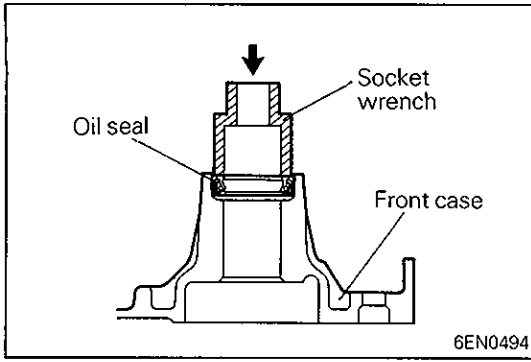

▶B▶ INSTALLATION OF OIL PUMP OIL SEAL

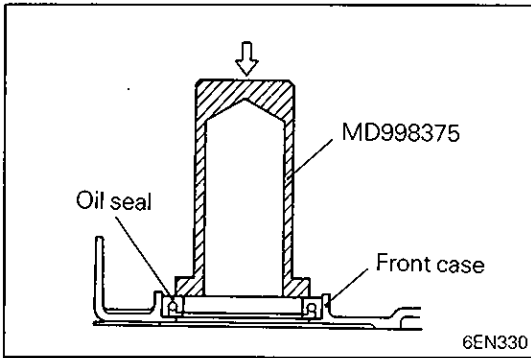

▶C▶ INSTALLATION OF CRANKSHAFT FRONT OIL SEAL

- (1) Using the special tool, install the crankshaft front oil seal into front case.

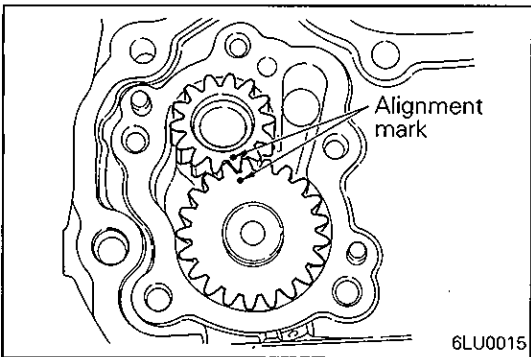

▶D▶ INSTALLATION OF OIL PUMP DRIVEN GEAR / OIL PUMP DRIVE GEAR

- (1) Apply engine oil to the gears and line up the alignment marks.

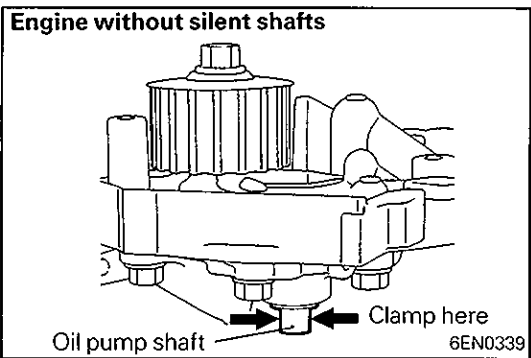

▶E▶ INSTALLATION OF FLANGE NUT (ENGINE WITHOUT SILENT SHAFTS)

- (1) Clamp the oil pump shaft end with vise.

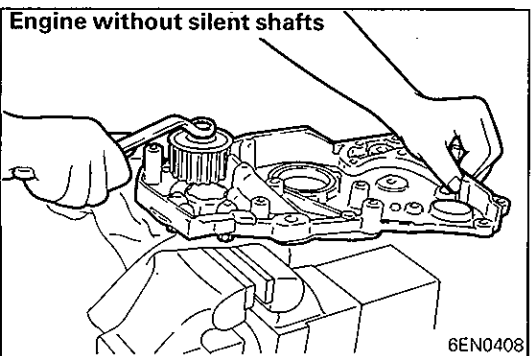

- (2) Tighten the oil pump sprocket nut to specified torque.

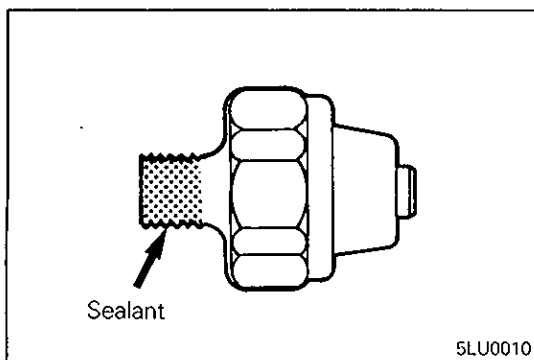

APPLICATION OF SEALANT TO OIL PRESSURE SWITCH

- (1) Coat the threads of switch with sealant and install the switch using the special tool.

Specified sealant: 3M ATD Part No.8660 or equivalent

Caution

1. Keep the end of threaded portion clear of sealant.
2. Avoid an overtightening.

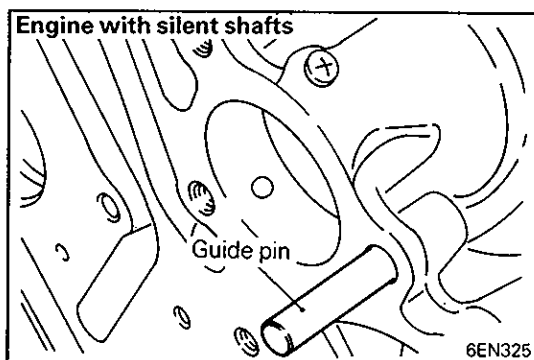

INSTALLATION OF RIGHT SILENT SHAFT REAR BEARING (ENGINE WITH SILENT SHAFTS)

- (1) Install the guide pin of the special tool in the threaded hole of the cylinder block as shown.

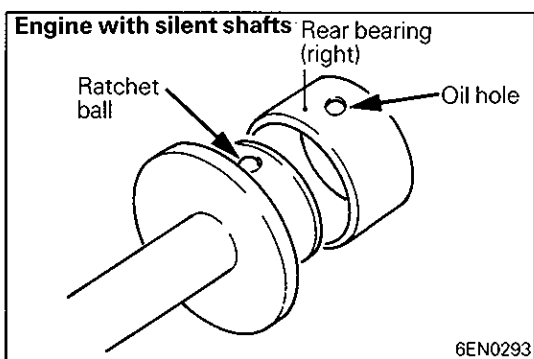

- (2) Align the ratchet ball of the special tool with the oil hole in the rear bearing to install the bearing on the special tool.
- (3) Apply engine oil to the outside circumference of the bearing and the bearing hole in the cylinder block.

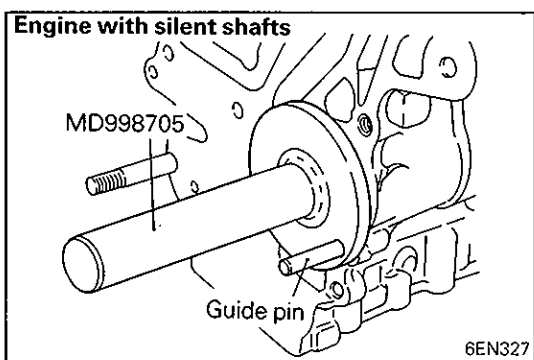

- (4) Insert the installer so that it is in alignment with the guide pin, and install the bearing in position.

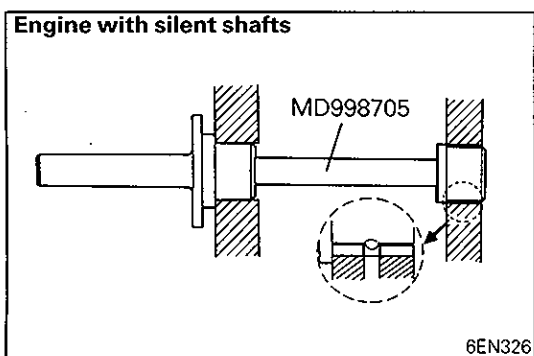

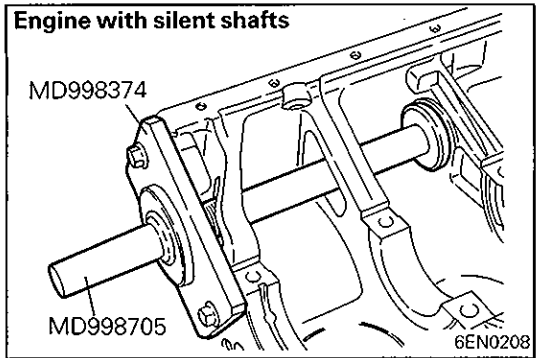

INSTALLATION OF LEFT SILENT SHAFT REAR BEARING (ENGINE WITH SILENT SHAFTS)

- (1) Install the special tool (MD998374) to the cylinder block.
- (2) Apply engine oil to the rear bearing outer circumference and bearing hole in cylinder block.

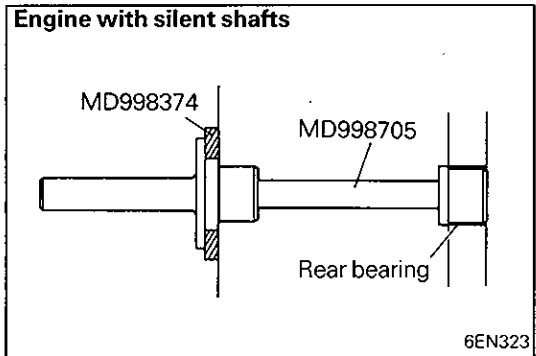

- (3) Using the special tool, install the rear bearing.

NOTE

The left rear bearing has no oil hole.

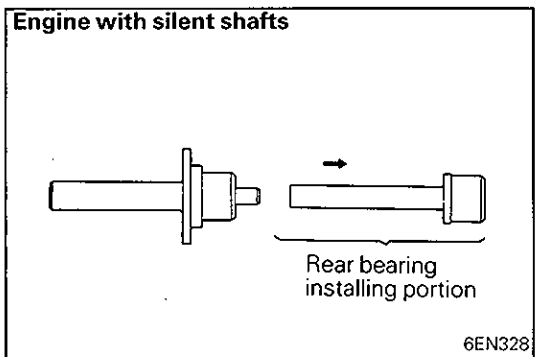

INSTALLATION OF SILENT SHAFT FRONT BEARING (ENGINE WITH SILENT SHAFTS)

- (1) Remove the rear bearing installing portion from the special tool.

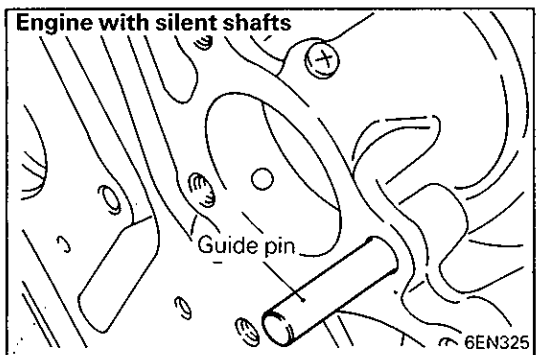

- (2) Install the guide pin of the special tool in the threaded hole of the cylinder block.

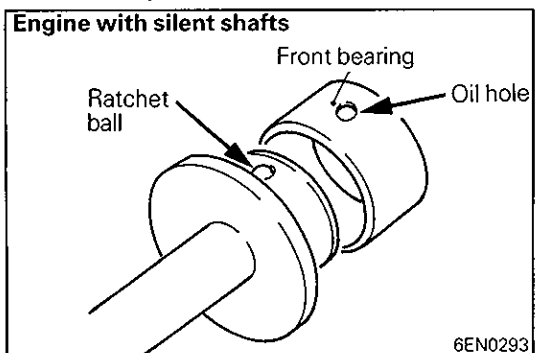

- (3) Align the ratchet ball of the special tool with the oil hole in the front bearing to install the bearing on the special tool.
- (4) Apply engine oil to the outside circumference of the bearing and the bearing hole in the cylinder block.

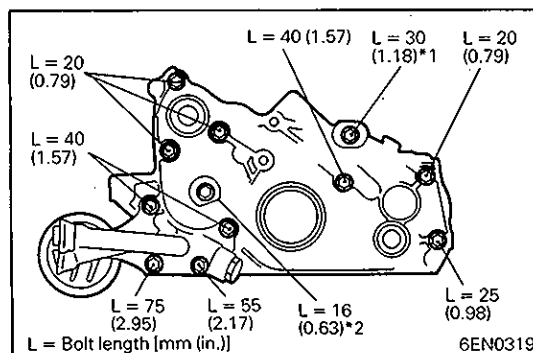
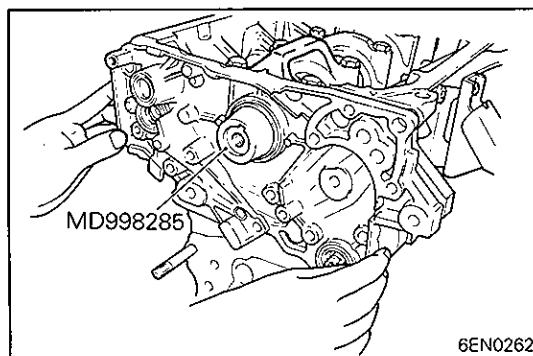
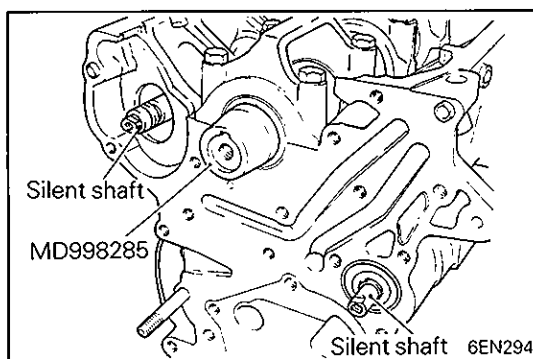
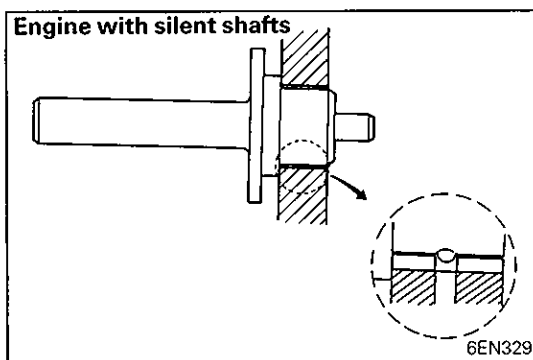
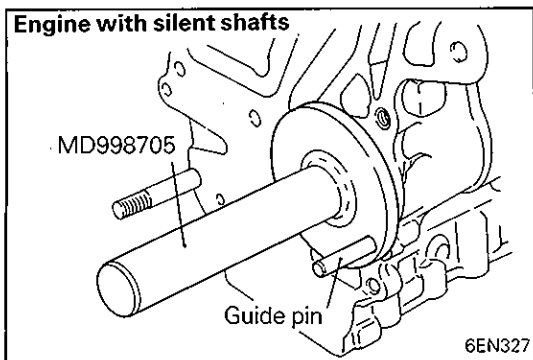

- (5) Insert the installer so that it is in alignment with the guide pin, and install the bearing in position.

◆J◆ INSTALLATION OF FRONT CASE

- (1) Set the special tool on the front end of crankshaft and apply a thin coat of engine oil to the outer circumference of the special tool to install the front case.

- (2) Install the front case assembly through a new front case gasket and temporarily tighten the flange bolts (other than those for tightening the filter bracket).

- (3) Mount the oil filter bracket with oil filter bracket gasket. Then, install the four bolts with washers.
- (4) Tighten the bolts to specification.

NOTE

1. The bolt marked with *1 in the illustration differs in tightening torque.
2. The bolt marked with *2 in the illustration is for engine without silent shafts only.

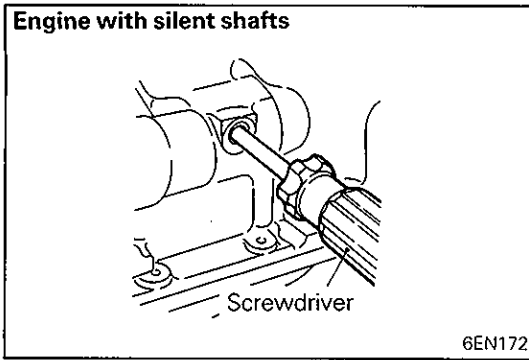

◆K◆ INSTALLATION OF FLANGE BOLT (ENGINE WITH SILENT SHAFTS)

- (1) Insert a Phillips screwdriver into a hole in the left side of the cylinder block to lock the silent shaft.

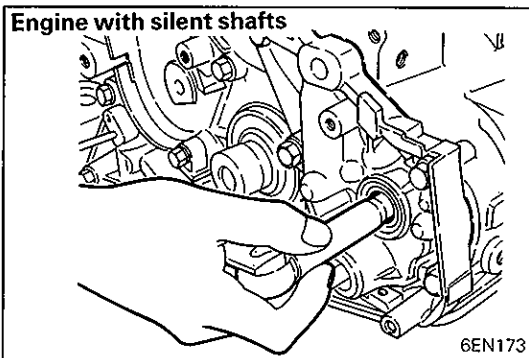

- (2) Secure the oil pump driven gear onto the left silent shaft by tightening the flange bolt to specified torque.

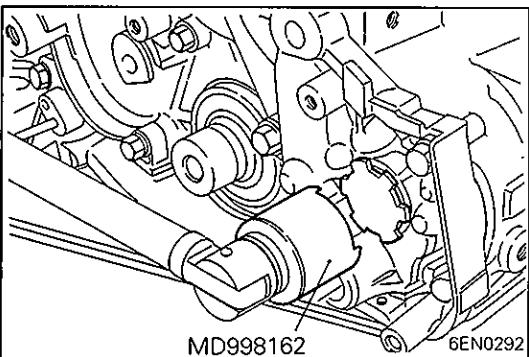

◆L◆ INSTALLATION OF PLUG

- (1) Install a new O-ring to the groove of front case.
- (2) Using the special tool, install the plug and tighten to specified torque.

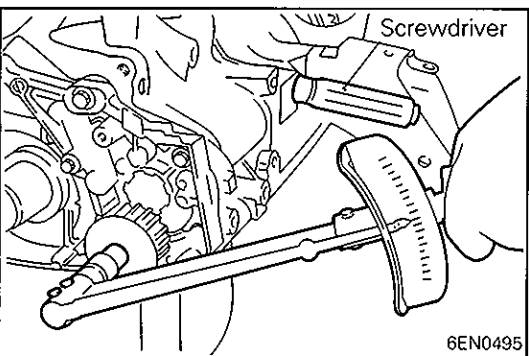

◆M◆ INSTALLATION OF FLANGE NUT

- (1) Referring to ◆J◆ (1), lock the silent shaft.
- (2) Tighten the flange nut to specified torque.

◆N◆ INSTALLATION OF OIL PAN

- (1) Clean both mating surface of oil pan and cylinder block.
- (2) Apply a 4 mm (0.16 in.) wide bead of sealant to the entire circumference of the oil pan flange.

Specified sealant:

MITSUBISHI GENUINE PART No. MD997110 or equivalent

- (3) The oil pan should be installed in 15 minutes after the application of sealant.

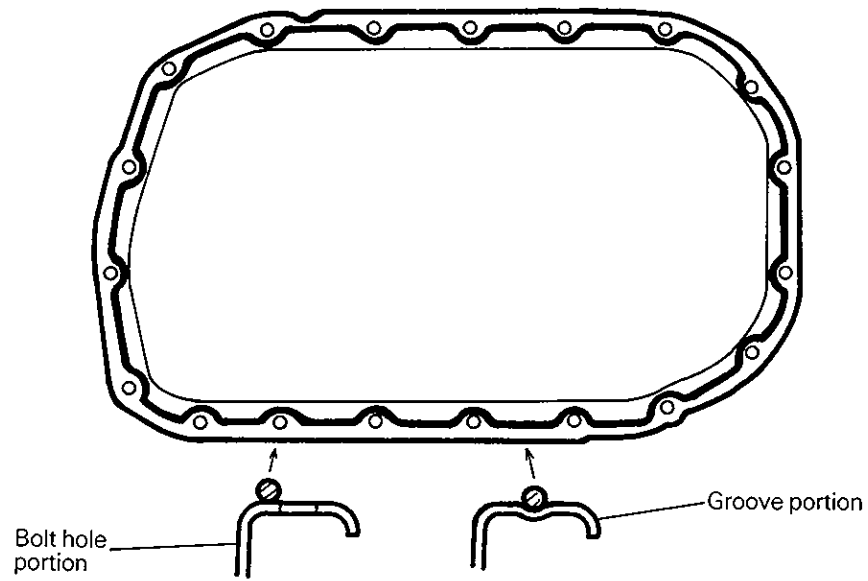

6EN0213

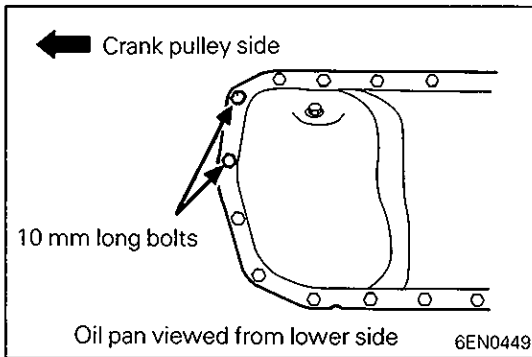

(4) Note the difference in bolt lengths at the location shown.

NOTES

14. PISTON AND CONNECTING ROD

REMOVAL AND INSTALLATION

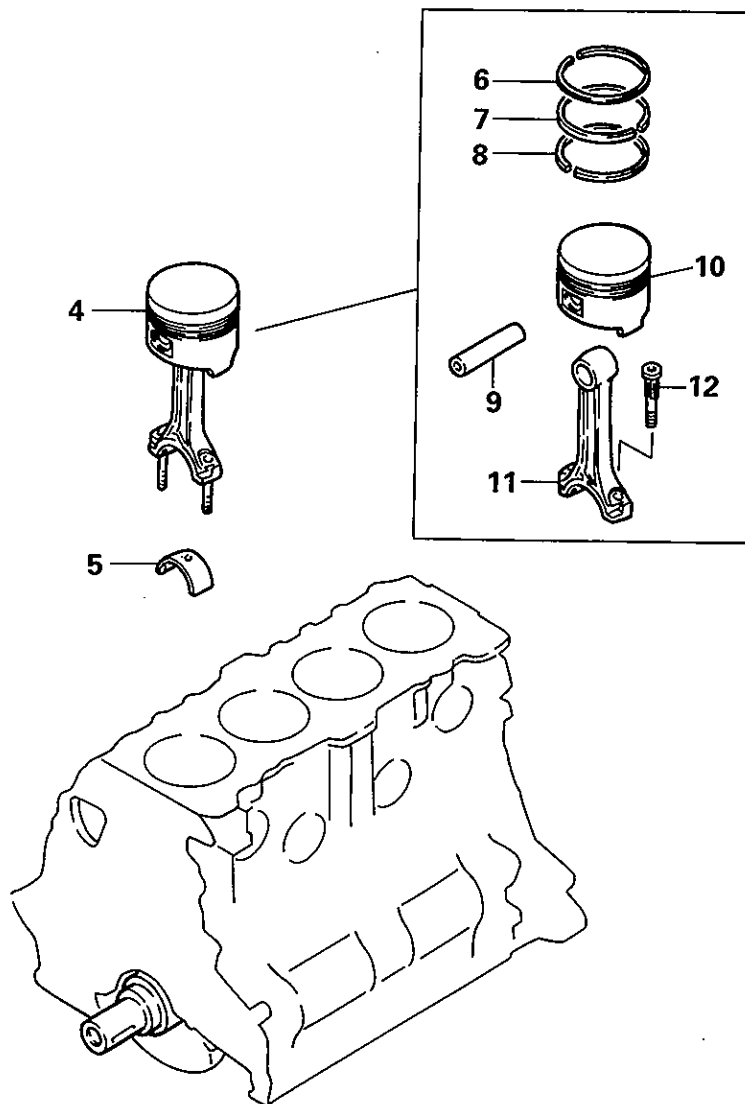

Removal steps

- 1. Nut
- ↔A↔ ↔E↔ 2. Connecting rod cap
- 3. Connecting rod bearing
- ↔D↔ 4. Piston and connecting rod assembly
- 5. Connecting rod bearing
- ↔C↔ 6. Piston ring No. 1
- ↔C↔ 7. Piston ring No. 2
- ↔B↔ 8. Oil ring
- ↔B↔ ↔A↔ 9. Piston pin
- 10. Piston
- 11. Connecting rod
- 12. Bolt

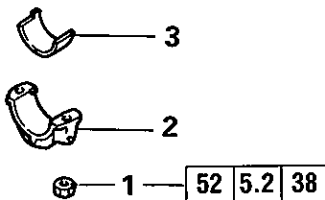

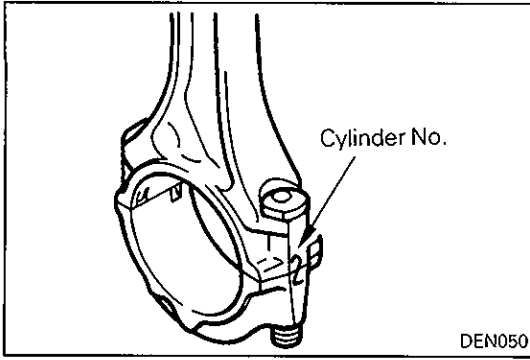

SERVICE POINTS OF REMOVAL

◊A◊ REMOVAL OF CONNECTING ROD CAP

- (1) Mark the cylinder number on the side of the connecting rod big end for correct reassembly.
- (2) Keep the removed connecting rods, caps, and bearings in order according to the cylinder number.

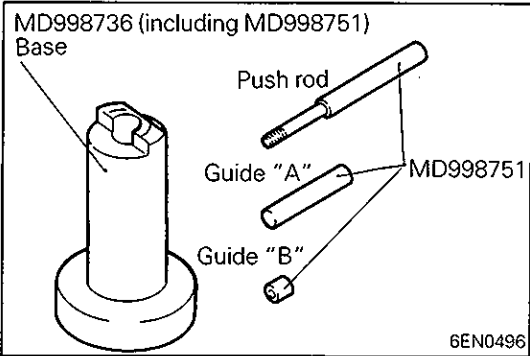

◊B◊ REMOVAL OF PISTON PIN

- (1) Insert the special tool, Push Rod, into the piston pin hole and install the special tool, Guide "B". Push Rod should be inserted in the reverse direction of the front mark stamped on the piston top surface.

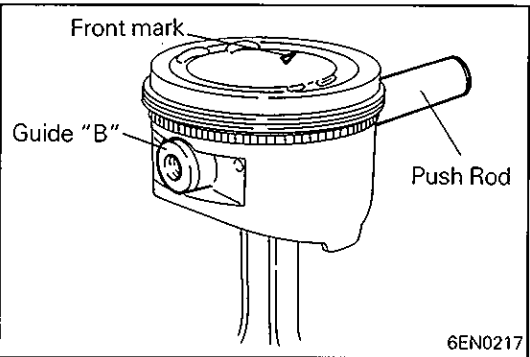

- (2) Set up the assembly described in step (1) onto the special tool, Base. Make sure that the piston top surface is positioned on the side indicated by the arrow stamped on the Base and set the piston with the front mark (arrow) on the top of the piston upward.

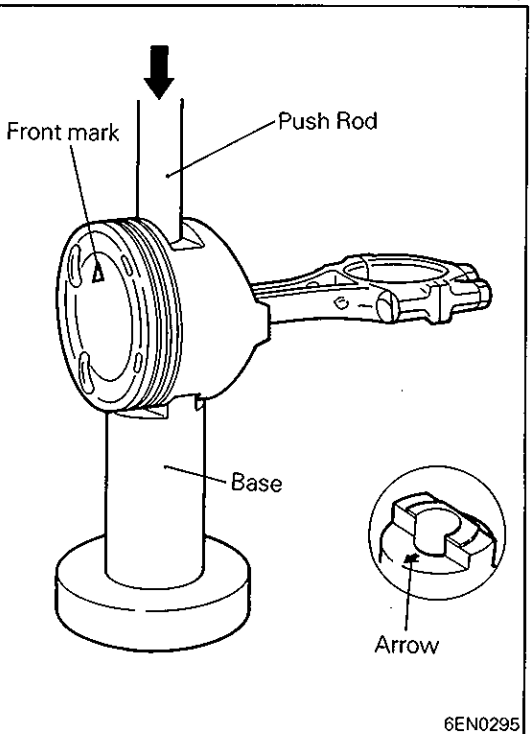

328

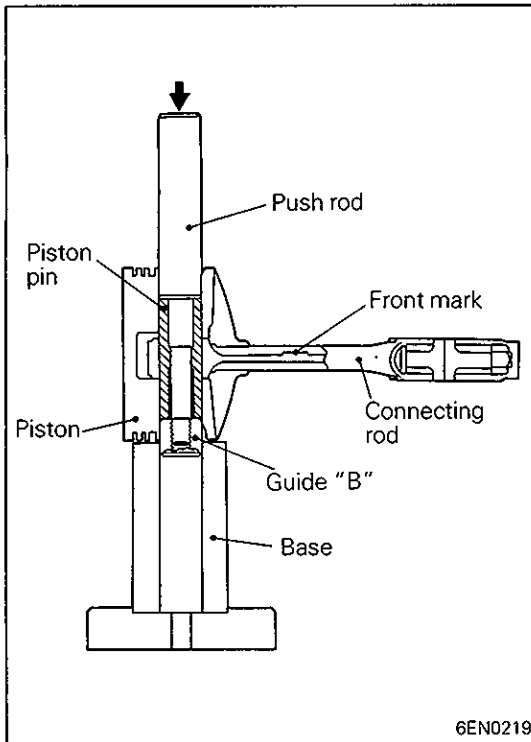

- (3) Using a press, drive out the piston pin.
- (4) Remove the press and the special tools.
- (5) Keep the disassembled piston pins and connecting rods in order according to the cylinder number.

INSPECTION

PISTON

- (1) Replace the piston if scratches or seizure is evident on its surfaces (especially the thrust surface). Replace the piston if it is cracked.

PISTON PIN

- (1) Insert the piston pin into the piston pin hole with a thumb. You should feel a slight resistance. Replace the piston pin if it can be easily inserted or there is an excessive play.
- (2) The piston and piston pin must be replaced as an assembly.

PISTON RING

- (1) Check the piston ring for damage, excessive wear, and breakage and replace if defects are evident. If the piston has been replaced with a new one, the piston rings must also be replaced with new ones.
- (2) Check for the clearance between the piston ring and ring groove. If the limit is exceeded, replace the ring or piston, or both.

Standard value:

0.03 – 0.07 mm (0.0012 – 0.0028 in.)	No.1
0.02 – 0.06 mm (0.0008 – 0.0024 in.)	No.2
Limit: 0.1 mm (0.004 in.)		

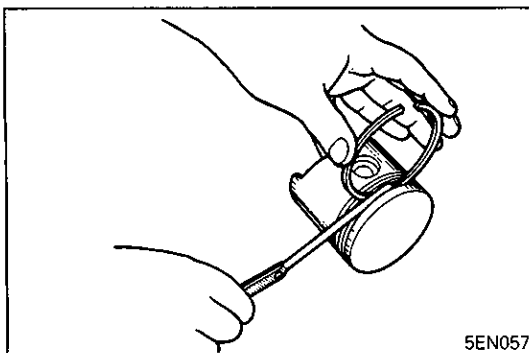

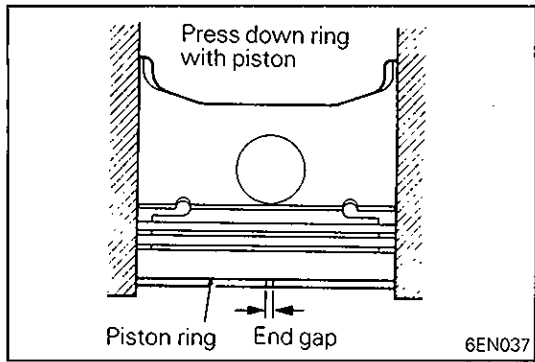

- (3) Install the piston ring into the cylinder bore. Force it down with a piston, its crown being in contact with the ring, to correctly position it at right angles to the cylinder wall. Then, measure the end gap with a feeler gauge. If the ring gap is excessive, replace the piston ring.

Standard value:

No. 1	0.25 – 0.40 mm (0.0098 – 0.0157 in.)	
No. 2	0.35 – 0.50 mm	
	(0.0138 – 0.0197 in.)	4G61
	0.20 – 0.35 mm	
	(0.0079 – 0.0138 in.)	4G63 – CARB
	0.45 – 0.60 mm	
	(0.0177 – 0.0236 in.)	4G67, 4G63 – MPI
	0.20 – 0.40 mm	
	(0.0079 – 0.0157 in.)	4G64
	0.33 – 0.48 mm	
	(0.0130 – 0.0189 in.)	4G64*
Oil	0.20 – 0.70 mm (0.0079 – 0.0276 in.)	

NOTE

*: E16A for Europe

Limit:

No. 1, No. 2	0.8 mm (0.031 in.)
Oil	1.0 mm (0.039 in.)

CONNECTING ROD BEARING

- (1) Visually check the bearing surface for uneven contact, streaks, scratches, and seizure. Replace if defects are evident. If streaks and seizure are excessive, check also the crankshaft. If damage is present on the crankshaft, replace crankshaft.
- (2) Measure the connecting rod bearing I.D. and crankshaft pin O.D. if the oil clearance exceeds the limit, replace bearing, and crankshaft if necessary.

Standard value: 0.02 – 0.05 mm (0.0008 – 0.0020 in.)

Limit: 0.1 mm (0.004 in.)

NOTE

For oil clearance measuring method using the plastic gauge, refer to the section CRANKSHAFT.

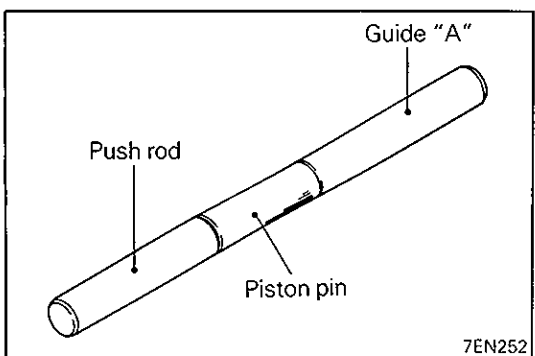

SERVICE POINTS OF INSTALLATION

◆◆ INSTALLATION OF PISTON PIN

- (1) Insert the special tool, Push Rod, into the piston pin and install the special tool, Guide "A".
- (2) Apply engine oil to the piston pin and guide.

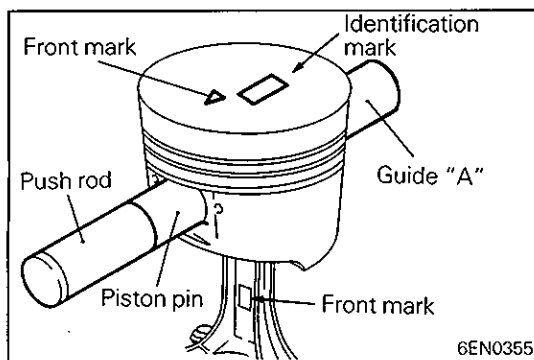

- (3) Apply engine oil to the piston pin hole and connecting rod small end.
- (4) Assemble the piston and connecting rod ensuring that the front mark is positioned on the same side. Then, insert the piston pin as assembled in step (1) into the piston pin hole, working with the Guide A first.

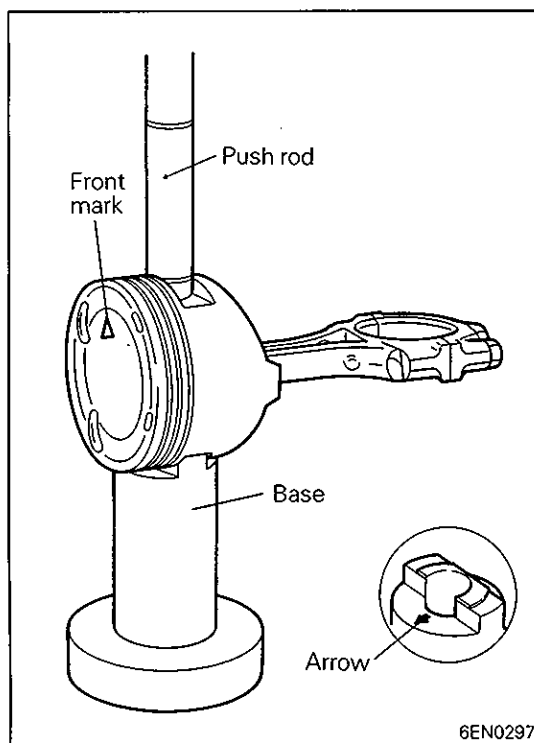

- (5) Set up the whole assembly onto the special tool, Base. Make sure that the piston top surface is positioned on the side indicated by the arrow stamped on the Base and set the piston with the front mark (arrow) on the top of the piston upward.

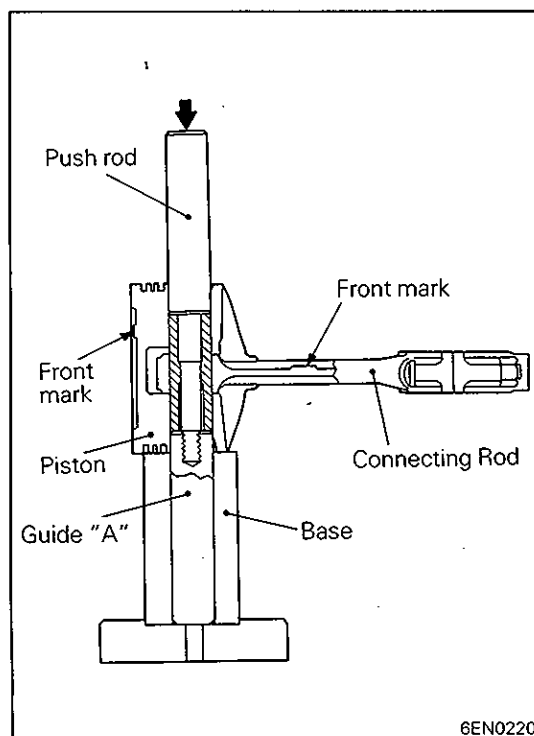

- (6) Using a press, press-fit the piston pin. If the press-fitting load is below the specification, replace the piston pin (piston assembly) or connecting rod, or both.
Standard value: 75,000 – 175,000 N (750 – 1,750 kg, 1,653 – 3,858 lbs.)

- (7) Remove the piston and connecting rod from the tool.

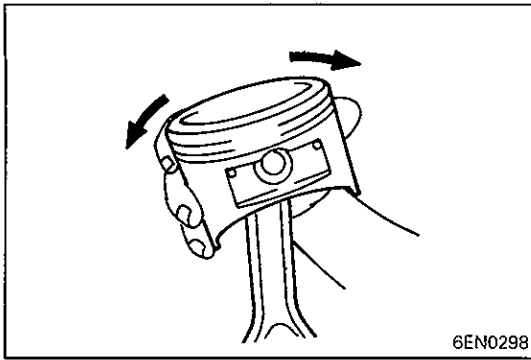

(8) Check that the piston moves smoothly.

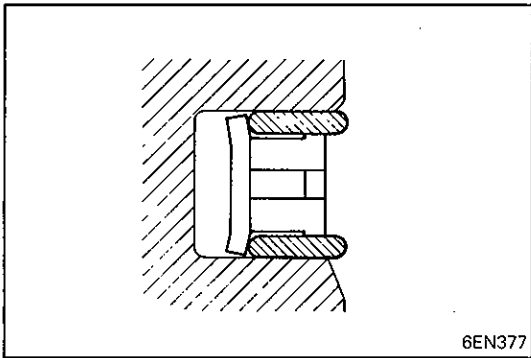

▶B◀ INSTALLATION OF OIL RING

(1) Fit the oil ring spacer into the piston ring groove.

NOTE

The side rails and spacer may be installed in either direction.

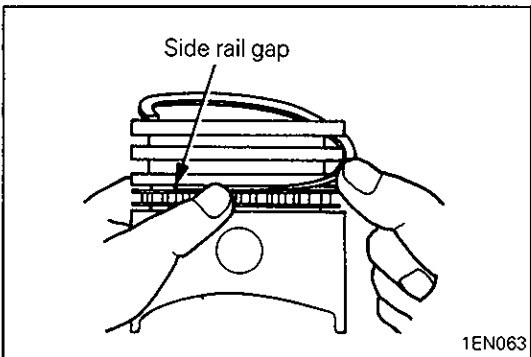

(2) Install the upper side rail.

To install the side rail, first fit one end of the rail into the piston groove, then press the remaining portion into position by finger. See illustration.

Use of ring expander to expand the side rail end gap can break the side rail, unlike other piston rings.

NOTE

Do not use piston ring expander when installing side rail.

(3) Install the lower side rail in the same procedure as described in step (2).

(4) Make sure that the side rails move smoothly in either direction.

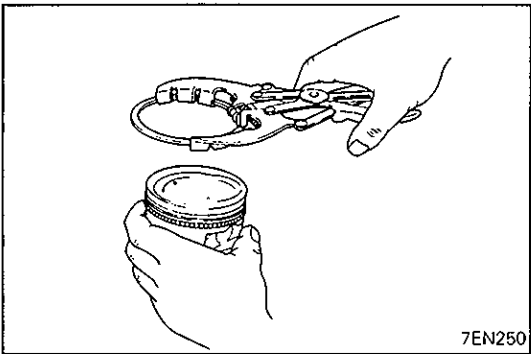

▶C◀ INSTALLATION OF PISTON RING NO. 2 / PISTON RING NO. 1

(1) Using piston ring expander, fit No. 2 and then No. 1 piston ring into position.

NOTE

(1) Note the difference in shape between No. 1 and No. 2 piston rings.

(2) Install piston rings No. 1 and No. 2 with their side having marks facing up (on the piston crown side).

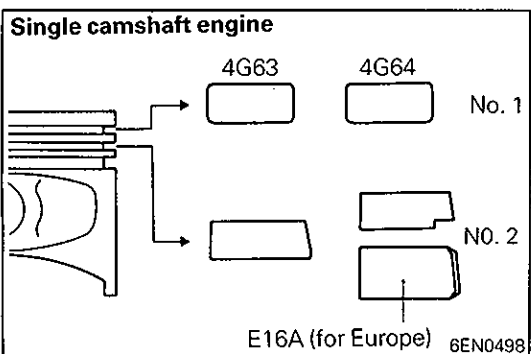

33

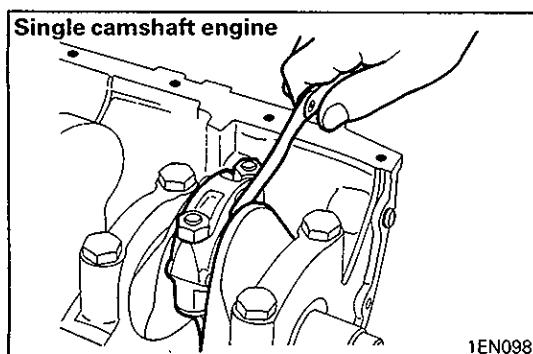
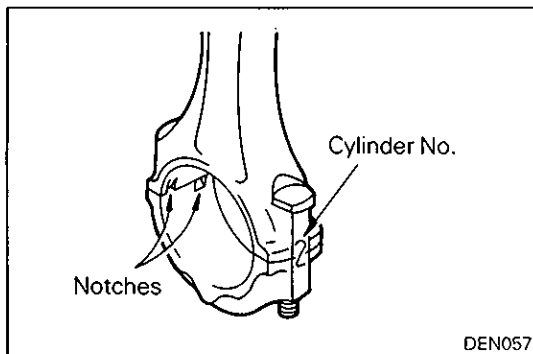
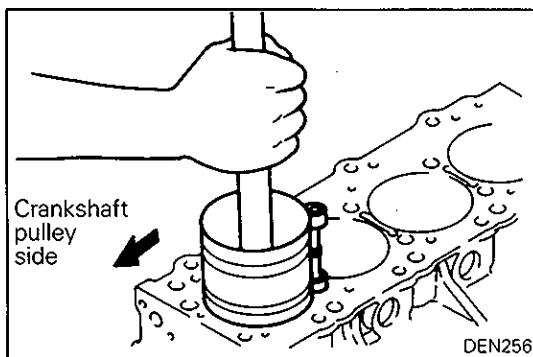
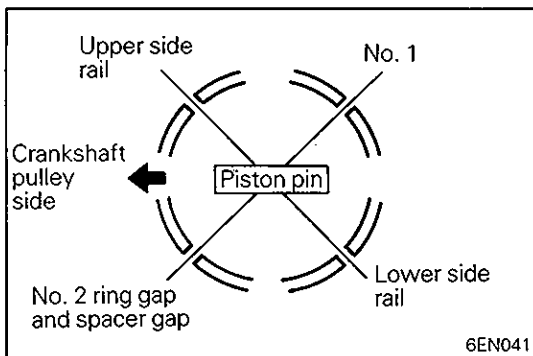
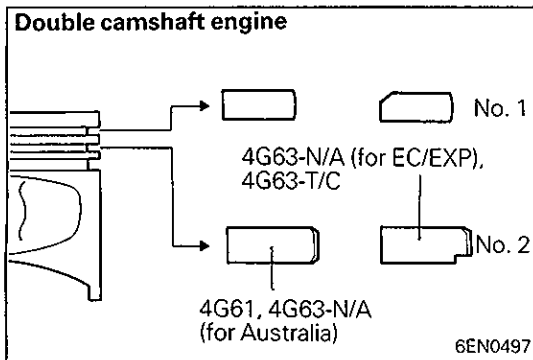

◆D◆ INSTALLATION OF PISTON AND CONNECTING ROD

- (1) Liberally coat engine oil on the circumference of the piston, piston ring, and oil ring.
- (2) Arrange the piston ring and oil ring gaps (side rail and spacer) as shown in the figure.
- (3) Rotate crankshaft so that crank pin is on center of cylinder bore.

- (4) Use suitable thread protectors on connecting rod bolts before inserting piston and connecting rod assembly into cylinder block. Care must be taken not to nick crank pin.
- (5) Using a suitable piston ring compressor tool, install piston and connecting rod assembly into cylinder block.

Caution

- Face the front mark (arrow) on the piston top forwards the engine front (timing belt).

◆E◆ INSTALLATION OF CONNECTING ROD CAP

- (1) Mate the correct bearing cap with the correct connecting rod by checking with the alignment marks marked during disassembly. If a new connecting rod is used which has no alignment mark, position the notches for locking the bearing on the same side.

- (2) Check if the thrust clearance in the connecting rod big end is correct.

Standard value: 0.10 – 0.25 mm (0.0039 – 0.0098 in.)
Limit: 0.4 mm (0.0157 in.)

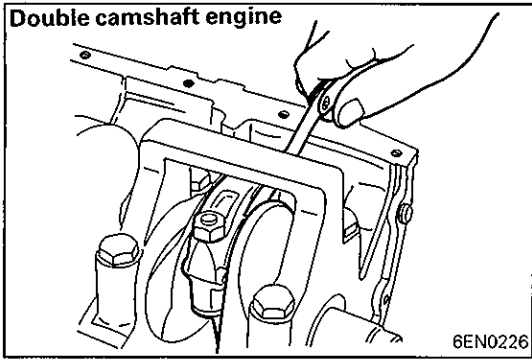

11-4

15. CRANKSHAFT, FLYWHEEL AND DRIVE PLATE

REMOVAL AND INSTALLATION

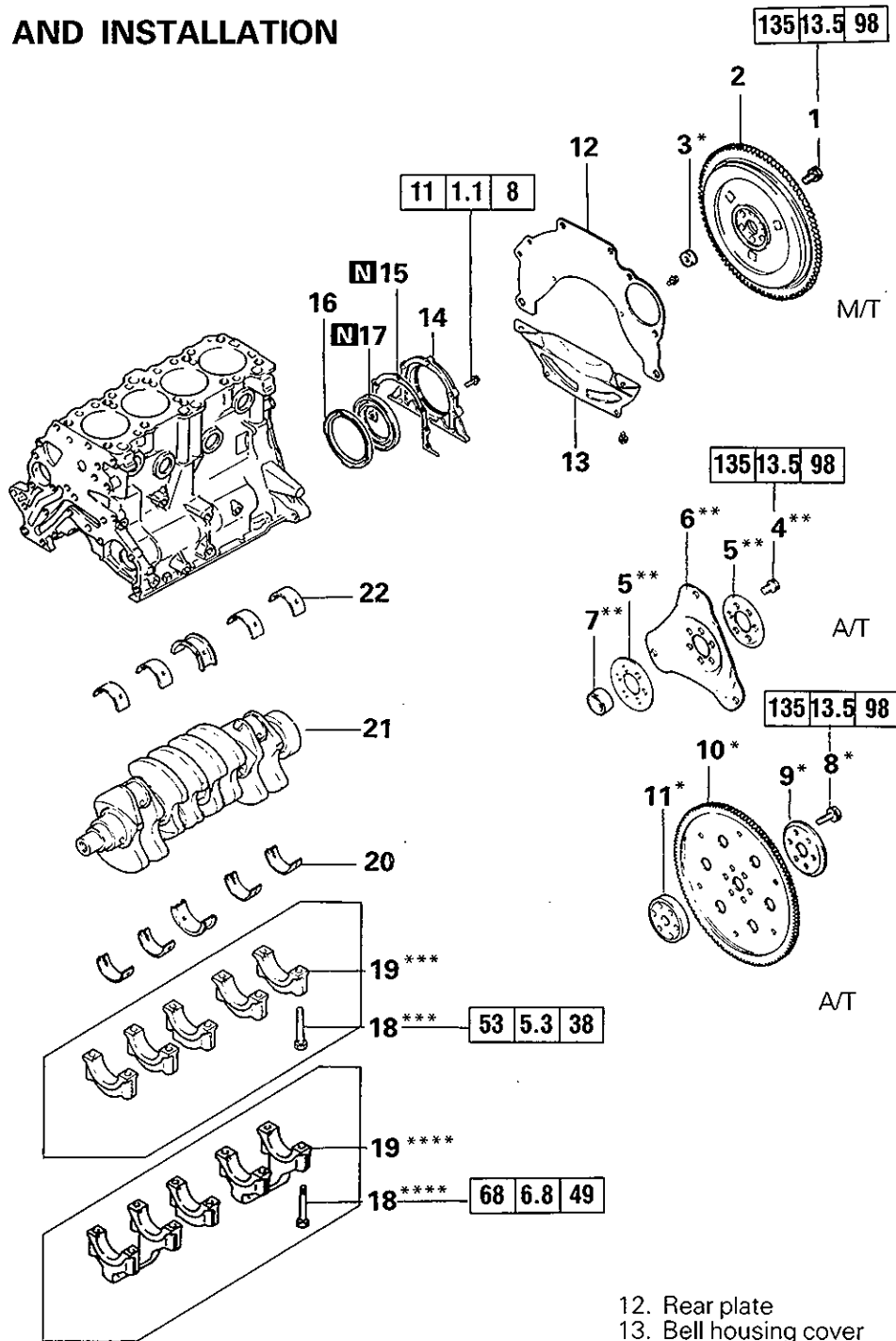

Removal steps

1. Flywheel bolt
2. Flywheel
3. Ball bearing*
4. Drive plate bolt**
5. Adapter plate**
6. Drive plate**
7. Crankshaft bushing**
8. Drive plate bolt*
9. Adapter plate*
10. Drive plate*
11. Crankshaft adapter*

12. Rear plate
13. Bell housing cover
14. Oil seal case
15. Gasket
- ▶D▶ 16. Oil separator
- ▶C▶ 17. Oil seal
- ▶B▶ 18. Bearing cap bolt
- ▶A▶ 19. Bearing cap
- ▶A▶ 20. Crankshaft bearing (lower)
- ▶A▶ 21. Crankshaft
- ▶A▶ 22. Crankshaft bearing (upper)

NOTE

- * : Rear wheel drive
- ** : Front wheel drive
- *** : Single camshaft engine
- **** : Double camshaft engine

INSPECTION**CRANKSHAFT**

- (1) Check the crankshaft journals and pins for streaks and seizure. Replace if necessary.

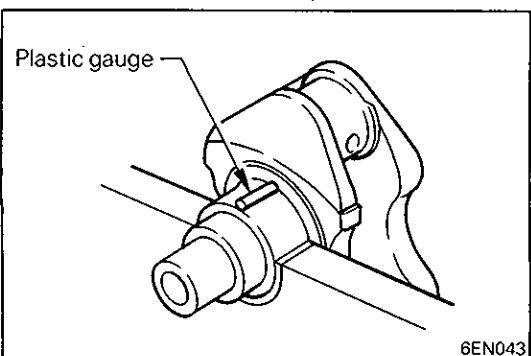
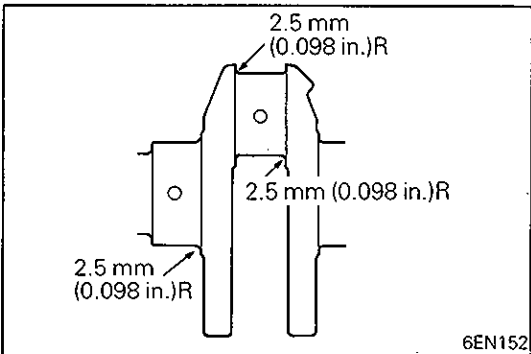
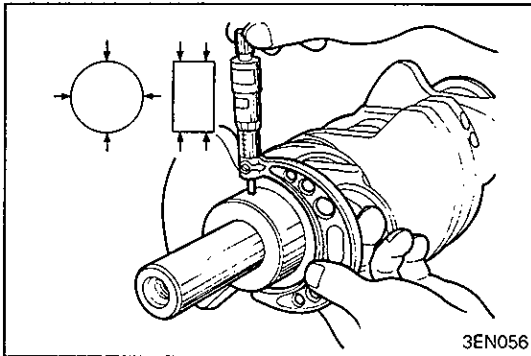
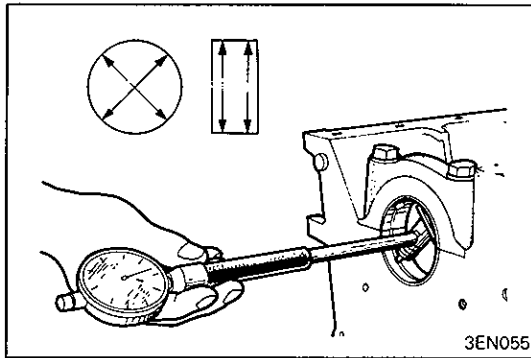

- (2) Measure the outside diameter of journal and inside diameter of crankshaft bearing. If the difference between them (oil clearance) exceeds the limit, replace the crankshaft bearing and, if necessary, crankshaft.

When the crankshaft is to be reused by machining to undersize, the crankshaft bearings should be changed to undersized ones.

Standard value: 0.02 – 0.05 mm (0.0008 – 0.0020 in.)
Limit: 0.1 mm (0.004 in.)

Caution

- Do not attempt an undersize machining on the crankshaft with special surface treatment. This crankshaft can be identified by its dull gray appearance.

- (3) When the crankshaft is machined to undersize, finish the fillets of journals and pins to the specified radius.

CRANKSHAFT OIL CLEARANCE (PLASTIC GAUGE METHOD)

The crankshaft oil clearance can be measured easily by using a plastic gauge, as follows:

- (1) Remove oil and grease and any other foreign matters from crankshaft journal and bearing inner surface.
- (2) Install the crankshaft.
- (3) Cut the plastic gauge to the same length as the width of bearing and place it on journal in parallel with its axis.

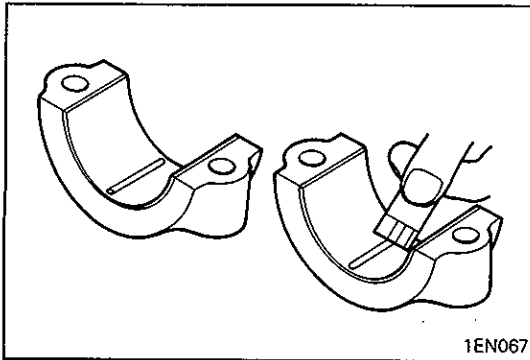

- (4) Gently place the crankshaft bearing cap over it and tighten the bolts to the specified torque.
- (5) Remove the bolts and gently remove the crankshaft bearing cap.
- (6) Measure the width of the smashed plastic gauge at its widest section by using a scale printed on the plastic gauge bag.

CRANKSHAFT REAR OIL SEAL

- (1) Check oil seal lip for wear and damage.
- (2) Check rubber for deterioration or hardening.
- (3) Check oil seal case for cracks and damage.

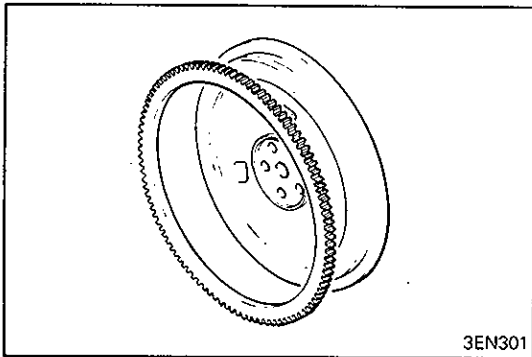

RING GEAR

- (1) Check teeth of ring gear for wear and damage. If necessary, replace the ring gear.
If the ring gear teeth are worn or damaged, also check the starter motor pinion.
To remove the ring gear, strike the ring gear at several points on its outer circumference. The ring gear cannot be removed if it is heated.
To install the ring gear, heat the ring gear to 300°C (572°F) for shrink fit.

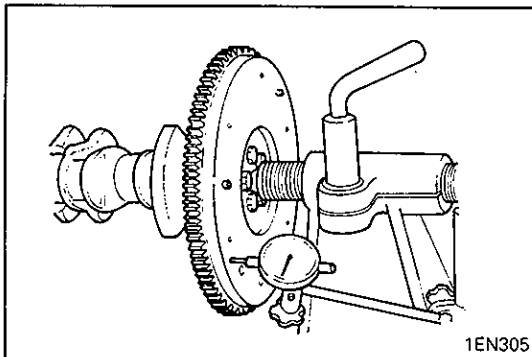

FLYWHEEL

- (1) Check the clutch disc friction surface for ridge wear, streaks, and seizure. If necessary, replace flywheel.
- (2) If the runout of flywheel exceeds the limit, replace.

Limit: 0.13 mm (0.0051 in.)

DRIVE PLATE

- (1) Check the drive plate for deformation, damage and cracks.
If necessary, replace.

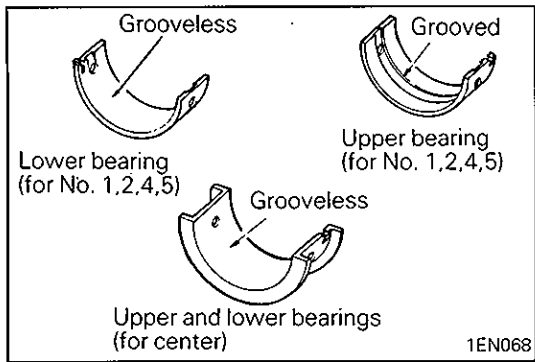

SERVICE POINTS OF INSTALLATION

◆A◆ IDENTIFICATION OF CRANKSHAFT BEARING

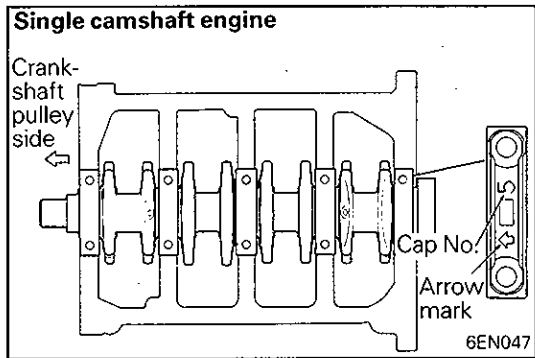

◆B◆ INSTALLATION OF BEARING CAPS

- (1) Check the bearing cap for the identification mark before it is installed.

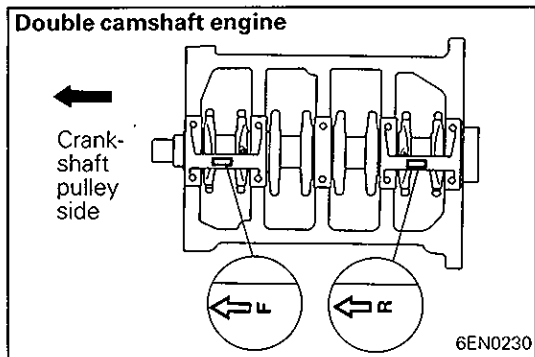

- (2) After installing the bearing caps, make sure that the crankshaft turns smoothly and the end play is correct. If the end play exceeds the limit, replace crankshaft bearings.

Standard value: 0.05 – 0.18 mm (0.0020 – 0.0071 in.)

Limit: 0.25 mm (0.0098 in.)

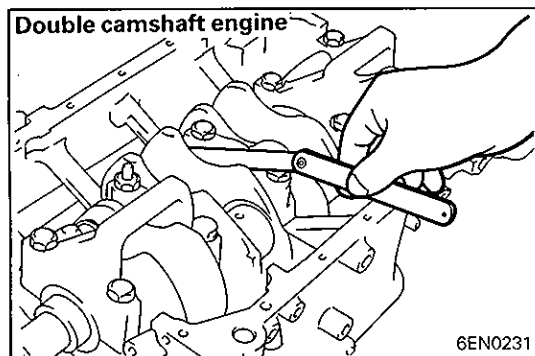
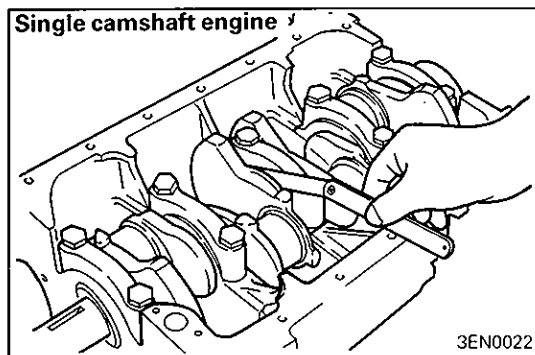

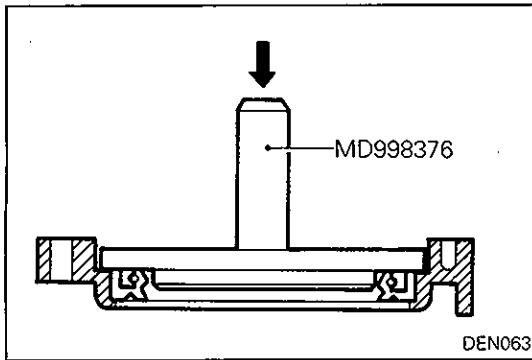
**◆C◆ INSTALLATION OF OIL SEAL**

- (1) Using the special tool, press-fit the oil seal into the crankshaft rear oil seal case. Use a new oil seal.

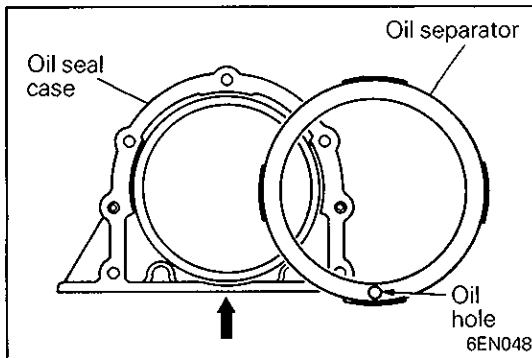
**◆D◆ INSTALLATION OF OIL SEPARATOR**

- (1) Force the oil separator into the oil seal case so that the oil hole in the separator is directed downward (arrow in illustration).

NOTES

16. CYLINDER BLOCK

Rear wheel drive and four wheel drive

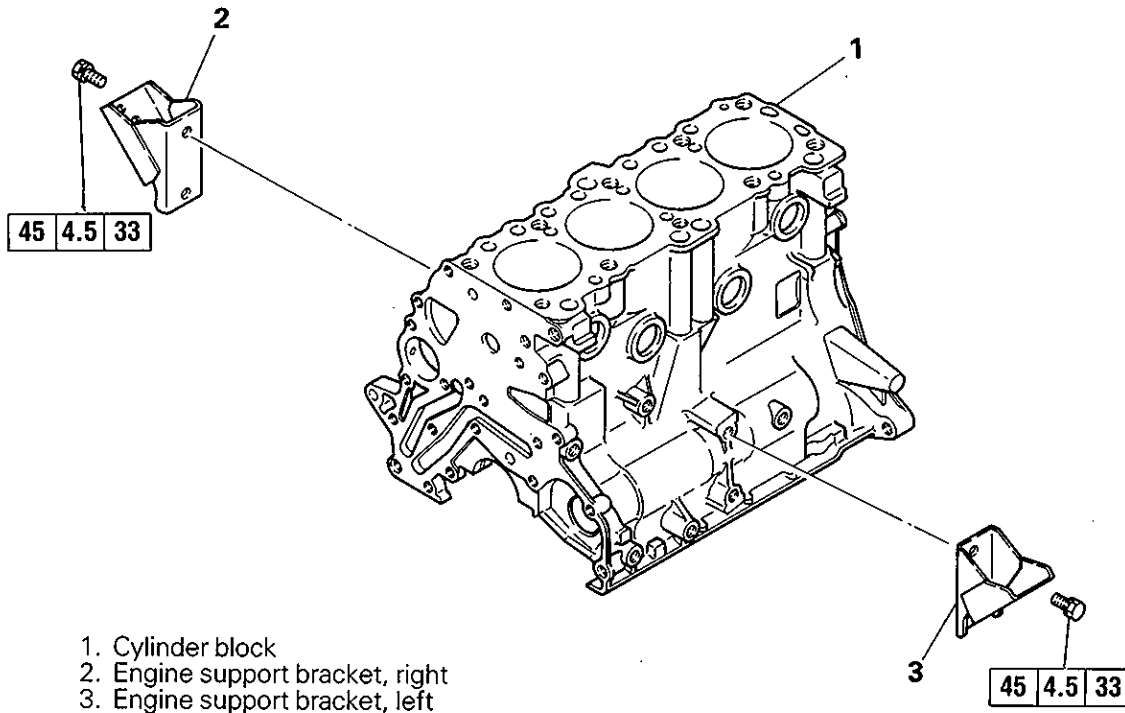

6EN350

Front wheel drive and all wheel drive

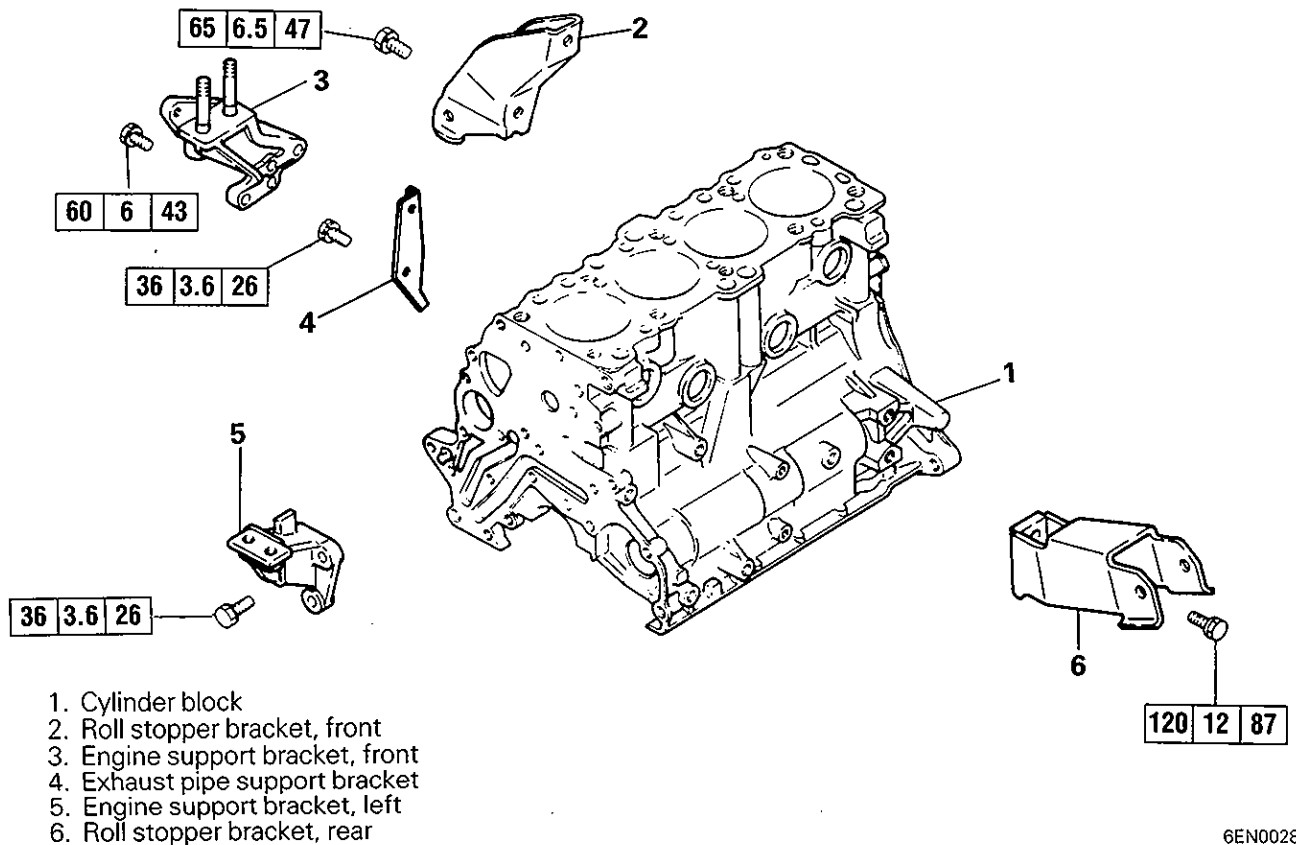

6EN0028

INSPECTION

NOTE

- (1) Clean parts to remove dust, oil, carbon deposits, and scale before starting the inspection and repair procedure.
- (2) Check cylinder block for water leaks and damage before cleaning.
- (3) Remove deposits from oil holes and make sure that they are not clogged.
- (4) Keep parts neatly arranged according to a matched pair.

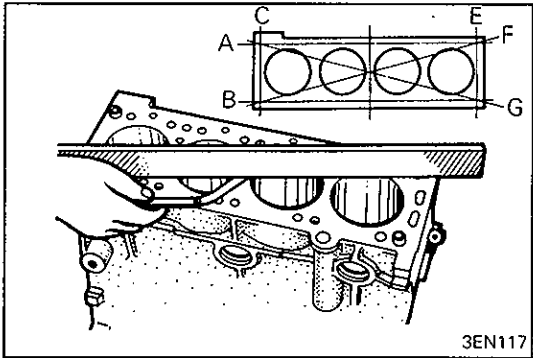

CYLINDER BLOCK

- (1) Visually check for scratches, rust, and corrosion. Use also a flaw detecting agent for the check. If defects are evident, correct, or replace.
- (2) Using a straightedge and feeler gauge, check the block top surface for warpage. Make sure that the surface is free from gasket chips and other foreign matter.

Standard value: 0.05 mm (0.0020 in.)

Limit: 0.1 mm (0.004 in.)

- (3) If the distortion is excessive, correct within the allowable limit or replace.

Grinding limit: 0.2 mm (0.008 in.)

The total thickness of the stock allowed to be removed from cylinder block and mating cylinder head is 0.2 mm (0.008 in.) at maximum.

Cylinder block height (when new):

274.9 – 275.1 mm (10.823 – 10.831 in.)	4G61
283.9 – 284.1 mm (11.177 – 11.185 in.)	4G63, 4G67
289.9 – 290.1 mm (11.413 – 11.421 in.)	4G64

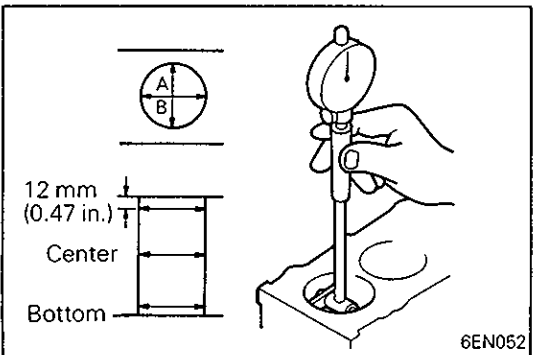

- (4) Check cylinder walls for scratches and seizure. If defects are evident, correct (bored to oversize) or replace.
- (5) Using cylinder gauge, measure the cylinder bore and cylindricity. If worn badly, correct cylinder to an oversize and replace piston and piston rings. Measure at the points shown in illustration.

Standard value:

Cylinder I.D.

4G61	82.30 – 82.33 mm (3.2402 – 3.2413 in.)
4G63	85.00 – 85.03 mm (3.3465 – 3.3476 in.)
4G64	86.50 – 86.53 mm (3.4055 – 3.4067 in.)
4G67	81.50 – 81.53 mm (3.2087 – 3.2098 in.)

Cylindricity 0.01 mm (0.0004 in.)

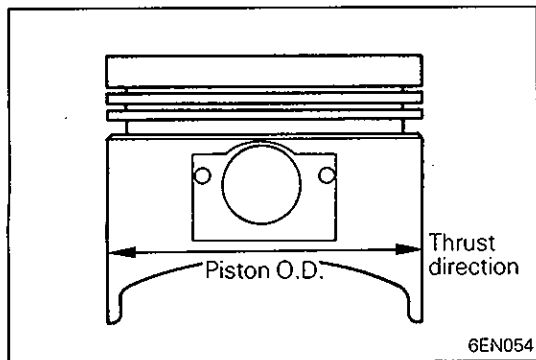

BORING CYLINDER

- (1) Oversize pistons to be used should be determined on the basis of the largest bore cylinder.

Piston size identification

Size	Identification mark
0.25 mm (0.01 in.) O.S.	0.25
0.50 mm (0.02 in.) O.S.	0.50
0.75 mm (0.03 in.) O.S.	0.75
1.00 mm (0.04 in.) O.S.	1.00

NOTE

Size mark is stamped on piston top.

- (2) Measure outside diameter of piston to be used. Measure it in thrust direction as shown.
 (3) Based on measured piston O.D. calculate boring finish dimension.

Boring finish dimension = Piston O.D. + (clearance between piston O.D. and cylinder) – 0.02 mm (0.0008 in.) (honing margin)

- (4) Bore all cylinders to calculated boring finish dimension.

Caution

- To prevent distortion that may result from temperature rise during honing, bore cylinders, working from No. 2 to No. 4 to No. 1 to No. 3.
- (5)hone to final finish dimension (piston O.D. + clearance between piston O.D. and cylinder).
 (6) Check clearance between piston and cylinder.

Clearance between piston and cylinder:

4G63 – CARB

0.01 – 0.03 mm (0.0004 – 0.0012 in.)

4G63 T/C

0.03 – 0.05 mm (0.0012 – 0.0020 in.)

4G63 – MPI – N/A, 4G64, 4G67

0.02 – 0.04 mm (0.0008 – 0.0016 in.)

NOTE

When boring cylinders, finish all of four cylinders to same oversize. Do not bore only one cylinder to an oversize.

NOTES