

FUEL SYSTEM

CONVENTIONAL TYPE CARBURETOR

CONTENTS

1. SPECIFICATIONS	13A-1- 1
GENERAL SPECIFICATIONS	13A-1- 1
CARBURETOR SPECIFICATIONS	13A-1-12
SERVICE SPECIFICATIONS	13A-1-17
TORQUE SPECIFICATIONS	13A-1-23
2. SPECIAL TOOLS	13A-2- 1
3. FUEL PUMP	13A-3- 1
4. CARBURETOR ASSEMBLY	13A-4- 1
5. CARBURETOR (Types "A" and "B")	13A-5- 1
6. CARBURETOR (Types "C" and "D")	13A-6- 1

1. SPECIFICATIONS

GENERAL SPECIFICATIONS – 1990 MODELS

Vehicle model	Engine	Trans- mission	Carburetor				Cold mixture heater	
			Type	Identification No.	Choke type	Fuel cut solenoid		
EC	Colt/ Lancer (C51A, C52A, C61A, C62A, C65A)	4G16	M/T	A	5EU A	Automatic (Wax type)	X	X
		4G13	M/T	A	5EU A	Automatic (Wax type)	X	X
				A	5EU B	Automatic (Wax type)	X	X
		4G15	M/T	A	5EU B	Automatic (Wax type)	X	X
				A	5EU A	Automatic (Wax type)	X	X
			A/T	A	5EV A	Automatic (Wax type)	X	X
		Lancer station wagon	4G15	M/T	A	3ET A	Automatic (Wax type)	X
	A				3ET B	Automatic (Wax type)	X	–
	A/T		A	3EU A	Automatic (Wax type)	X	–	
			A	3EU B	Automatic (Wax type)	X	–	
	Lancer station wagon-4WD	4G37	M/T	A	5EC A	Automatic (Wax type)	X	–
	Space wagon	4G37	M/T	A	5EC B	Automatic (Wax type)	X	–
			A/T	A	5EN A	Automatic (Wax type)	X	–
	Space wagon-4WD	4G63	M/T	A	3EW C	Automatic (Wax type)	X	–
L300	4G32 (Van)	M/T	A	5EI A	Automatic (Wax type)	X	–	
	4G32 (Truck)	M/T	A	5ED A	Automatic (Wax type)	X	–	
	4G63	M/T	A	5EE A	Automatic (Wax type)	X	X	
L300-4WD	4G63	M/T						

Vehicle model	Engine	Trans- mission	Carburetor				Cold mixture heater	
			Type	Identification No.	Choke type	Fuel cut solenoid		
EC	L200	4G32	M/T	A	3EX A	Automatic (Wax type)	X	-
		4G63	M/T	A	3EZ A	Automatic (Wax type)	X	X
	L200-4WD	4G63	M/T					
	Pajero/ Montero	4G54	M/T	C	32-35DIDTA-389	Automatic (Wax type)	X	-
Australia	Lancer (C62A)	4G15	M/T	C	30-32DIDTA-342	Automatic (Wax type)	X	X
			A/T	C	30-32DIDTA-343	Automatic (Wax type)	X	X
	Space wagon	4G63	M/T	C	32-35DIDTA-382	Automatic (Wax type)	X	-
			A/T	C	32-35DIDTA-383	Automatic (Wax type)	X	-
	L300	4G63	M/T	C	32-35DIDTA-386	Automatic (Wax type)	X	-
			A/T	C	32-35DIDTA-387	Automatic (Wax type)	X	-
	L200	4G54	M/T	C	32-35DIDTA-388	Automatic (Wax type)	X	-
	L200-4WD	4G54	M/T	C	32-35DIDTA-378	Automatic (Wax type)	X	-
	Pajero	4G54	M/T	C	32-35DIDTA-380	Automatic (Wax type)	X	-

Vehicle model	Engine	Transmission	Carburetor				Cold mixture heater	
			Type	Identification No.	Choke type	Fuel cut solenoid		
EXP	Colt/ Lancer (C51A, C52A, C61A, C62A)	M/T	B	5XU A	Manual	X	–	
			A	5WU A	Automatic (Wax type)	X	–	
			A	5EU A	Automatic (Wax type)	X	X	
		A/T	B	5XU B	Manual	X	–	
			A	5EV A	Automatic (Wax type)	X	X	
	4G15	M/T	B	5XU A	Manual	X	–	
			A	5WU A	Automatic (Wax type)	X	–	
			A	5EU A	Automatic (Wax type)	X	X	
		A/T	B	5XU B	Manual	X	–	
			A	5WU B	Automatic (Wax type)	X	–	
			A	5EV A	Automatic (Wax type)	X	X	
Lancer station wagon	4G13	M/T	B	3XT B	Manual	X	–	
			A	3WT C	Automatic (Wax type)	X	–	
			A	3ET A	Automatic (Wax type)	X	–	
	4G15	M/T	B	3XT B	Manual	X	–	
			A	3WT C	Automatic (Wax type)	X	–	
			A	3ET A	Automatic (Wax type)	X	–	
		A/T	B	3XT B	Manual	X	–	
			A	3WT D	Automatic (Wax type)	X	–	
			A	3EU A	Automatic (Wax type)	X	–	
	Lancer station wagon-4WD	4G37	M/T	B	5XC C	Manual	X	–
				A	5EC A	Automatic (Wax type)	X	–

Vehicle model	Engine	Trans- mission	Carburetor				Cold mixture heater	
			Type	Identification No.	Choke type	Fuel cut solenoid		
EXP	Space wagon	4G37	M/T	B	5XC D	Manual	X	–
				A	5EC B	Automatic (Wax type)	X	–
		A/T	B	5XC D	Manual	X	–	
			A	5EN A	Automatic (Wax type)	X	–	
		4G63	M/T	B	3XW C	Manual	X	–
	L300	4G33	M/T	B	5XJ A	Manual	X	–
				B	5AJ A	Manual	X	–
		4G32	M/T	B	5XJ A	Manual	X	–
				B	5AJ A	Manual	X	–
	4G63	M/T	B	5XK A	Manual	X	–	
		A/T						
	L300-4WD	4G63	M/T	B	5XK A	Manual	X	–
				B	5CK A	Manual	X	–
	L200	4G32	M/T	B	3XA D	Manual	X	–
		4G63	M/T	B	1XL D	Manual	X	–
	L200-4WD	4G63	M/T					
Pajero	4G54	M/T	D	32-35DIDSA-21	Manual	X	–	
			D	32-35DIDSA-22	Manual	X	–	
GCC	Colt/ Lancer (C51A, C52A, C61A, C62A)	4G13	M/T	A	5EU A	Automatic (Wax type)	X	–
			A/T	A	5EU A	Automatic (Wax type)	X	–
				A	5EV A	Automatic (Wax type)	X	–
	Lancer station wagon	4G15	M/T	A	3AT A	Automatic (Wax type)	X	–
			A/T	A	3EU A	Automatic (Wax type)	X	–
	Space wagon	4G37	M/T	B	5AC B	Manual	X	–
			A/T	B	5AC C	Manual	X	–

Vehicle model			Engine	Trans- mission	Carburetor				Cold mixture heater
					Type	Identification No.	Choke type	Fuel cut solenoid	
EXP	GCC	Galant (E32A, E33A)	4G37	M/T	A	5AP A	Automatic (Wax type)	X	–
				A/T	A	5AP B	Automatic (Wax type)	X	–
			4G63	M/T	A	5AR A	Automatic (Wax type)	X	–
				A/T	A	5AR B	Automatic (Wax type)	X	–
		L300	4G32	M/T	B	5AJ A	Manual	X	–
			4G63	A/T	B	5AZ A	Manual	X	–
		L200	4G63	M/T	B	3AW A	Manual	X	–
		L200-4WD	4G63	M/T					
		Pajero/ Montero	4G54	M/T	D	32-35DIDSA-20	Manual	X	–
				A/T	D	32-35DIDSA-20	Manual	X	–

NOTE

M/T: Manual Transmission

4WD: Four Wheel Drive

A/T: Automatic Transmission

X: Applicable

–: Not Applicable

GCC: Gulf Cooperation Council

GENERAL SPECIFICATIONS – 1991 MODELS

Vehicle model	Engine	Trans- mission	Carburetor				Cold mixture heater	
			Type	Identification No.	Choke type	Fuel cut solenoid		
EC	Colt/ Lancer (C65A)	4G16	M/T	A	5EU A	Automatic (Wax type)	X	X
	Lancer station wagon-4WD	4G37	M/T	A	5EC A	Automatic (Wax type)	X	–
	Galant (E31A, E32A)	4G32	M/T	A	5EO A	Automatic (Wax type)	X	X
			A/T	A	5XO B	Automatic (Wax type)	X	X
		4G37	M/T	A	5EP A	Automatic (Wax type)	X	X
			A/T	A	5EQ A	Automatic (Wax type)	X	X
	Space wagon	4G37	M/T	A	5EC B	Automatic (Wax type)	X	–
			A/T	A	5EN A	Automatic (Wax type)	X	–
	Space wagon-4WD	4G63	M/T	A	3EW C	Automatic (Wax type)	X	–
	L300	4G32 (Van)	M/T	A	5EI A	Automatic (Wax type)	X	–
			M/T	A	5ED A	Automatic (Wax type)	X	–
			M/T	A	5EE A	Automatic (Wax type)	X	X
	L300-4WD	4G63	M/T					
	L200	4G32	M/T	A	3EX A	Automatic (Wax type)	X	–
			M/T	A	3EZ A	Automatic (Wax type)	X	X
	L200-4WD	4G63	M/T					
Australia	Sigma	4G54	M/T	C	32-35DIDTA-391	Automatic (Wax type)	X	–
			A/T	C	32-35DIDTA-392	Automatic (Wax type)	X	–
	Space wagon	4G63	M/T	C	32-35DIDTA-382	Automatic (Wax type)	X	–
			A/T	C	32-35DIDTA-383	Automatic (Wax type)	X	–

CONVENTIONAL CARB – Specifications

13A-1-7

Vehicle model	Engine	Trans- mission	Carburetor				Cold mixture heater	
			Type	Identification No.	Choke type	Fuel cut solenoid		
Australia	L300	4G63	M/T	C	32-35DIDTA-386	Automatic (Wax type)	X	–
			A/T	C	32-35DIDTA-387	Automatic (Wax type)	X	–
	L200	4G54	M/T	C	32-35DIDTA-388	Automatic (Wax type)	X	–
	L200-4WD	4G54	M/T	C	32-35DIDTA-378	Automatic (Wax type)	X	–
	Pajero	4G54	M/T	C	32-35DIDTA-393	Automatic (Wax type)	X	–
EXP	Lancer station wagon-4WD	4G37	M/T	B	5XC C	Manual	X	–
				A	5EC A	Automatic (Wax type)	X	–
	Galant (E31A, E32A, E33A)	4G32	M/T	B	5XO A	Manual	X	–
				A	5WO A	Automatic (Wax type)	X	–
				A	5EO A	Automatic (Wax type)	X	X
				A/T	A	5XO B	Automatic (Wax type)	X
	4G37	M/T	B	5XP A	Manual	X	–	
				5WP A	Automatic (Wax type)	X	–	
				5EP A	Automatic (Wax type)	X	X	
			A/T	B	5XP B	Manual	X	–
				A	5WP B	Automatic (Wax type)	X	–
				A	5EO A	Automatic (Wax type)	X	X
	4G63	M/T	B	5XR A	Manual	X	–	
			A/T	B	5XR B	Manual	X	–
	Space wagon	4G37	M/T	B	5XC D	Manual	X	–
				A	5EC B	Automatic (Wax type)	X	–
			A/T	B	5XC D	Manual	X	–
				A	5EN A	Automatic (Wax type)	X	–
	4G63	M/T	B	3XW C	Manual	X	–	

Vehicle model	Engine	Trans- mission	Carburetor				Cold mixture heater	
			Type	Identification No.	Choke type	Fuel cut solenoid		
EXP	L300	4G33	M/T	B	5XJ A	Manual	X	-
				B	5AJ A	Manual	X	-
	4G32	M/T	B	5XJ A	Manual	X	-	
			B	5AJ A	Manual	X	-	
	4G63	M/T	B	5XK A	Manual	X	-	
			A/T					
	L300-4WD	4G63	M/T	B	5XK A	Manual	X	-
				B	5CK A	Manual	X	-
	L200	4G32	M/T	B	3XA D	Manual	X	-
				4G63	M/T	B	1XL D	Manual
	L200-4WD	4G63	M/T					
	Pajero/ Montero	4G54	M/T	D	32-35DIDSA-21	Manual	X	-
				D	32-35DIDSA-22	Manual	X	-
	GCC	Galant (E32A, E33A)	4G37	M/T	A	5AP A	Automatic (Wax type)	X
A/T				A	5AP B	Automatic (Wax type)	X	-
4G63			M/T	A	5AR A	Automatic (Wax type)	X	-
			A/T	A	5AR B	Automatic (Wax type)	X	-
Space wagon		4G37	M/T	B	5AC B	Manual	X	-
			A/T	B	5AC C	Manual	X	-
L300		4G32	M/T	B	5AJ A	Manual	X	-
				4G63	M/T	B	5AZ A	Manual
		A/T						
L200		4G63	M/T	B	3AW A	Manual	X	-
		4G54	M/T	D	32-35DIDSA-23	Manual	X	-
L200-4WD		4G63	M/T	B	3AW A	Manual	X	-
Pajero/ Montero		4G54	M/T	D	32-32DIDSA-20	Manual	X	-
			A/T	D	32-32DIDSA-20	Manual	X	-

NOTE

M/T: Manual Transmission

4WD: Four Wheel Drive

A/T: Automatic Transmission

X: Applicable

-: Not Applicable

GCC: Gulf Cooperation Council

GENERAL SPECIFICATIONS – 1992 MODELS

Vehicle model	Engine	Trans- mission	Carburetor				Cold mixture heater	
			Type	Identification No.	Choke type	Fuel cut solenoid		
EC	Galant (E31A, E32A)	4G32	M/T	A	5EO A	Automatic (Wax type)	X	X
			A/T	A	5XO B	Automatic (Wax type)	X	X
		4G37	M/T	A	5EP A	Automatic (Wax type)	X	X
			A/T	A	5EQ A	Automatic (Wax type)	X	X
	L300	4G32 (Van)	M/T	A	5EI A	Automatic (Wax type)	X	–
			M/T	A	5ED A	Automatic (Wax type)	X	–
		4G63	M/T	A	5EE A	Automatic (Wax type)	X	X
			A/T	A	7EG A	Automatic (Wax type)	X	X
	L300-4WD	4G63	M/T	A	5EE A	Automatic (Wax type)	X	X
	L200	4G32	M/T	A	3EX A	Automatic (Wax type)	X	–
			M/T	A	3EZ A	Automatic (Wax type)	X	X
	L200-4WD	4G63	M/T					
Australia	L300	4G63	M/T	C	32-35DIDTA-386	Automatic (Wax type)	X	–
			A/T	C	32-35DIDTA-387	Automatic (Wax type)	X	–
	L200	4G54	M/T	C	32-35DIDTA-388	Automatic (Wax type)	X	–
	L200-4WD	4G54	M/T	C	32-35DIDTA-378	Automatic (Wax type)	X	–

Vehicle model	Engine	Transmission	Carburetor				Cold mixture heater		
			Type	Identification No.	Choke type	Fuel cut solenoid			
EXP	Galant (E31A, E32A, E33A)	4G32	M/T	B	5XO A	Manual	X	–	
				A	5WO A	Automatic (Wax type)	X	–	
				A	5EO A	Automatic (Wax type)	X	X	
		A/T	A	5XO B	Automatic (Wax type)	X	X		
		4G37	M/T	M/T	B	5XP A	Manual	X	–
					A	5WP A	Automatic (Wax type)	X	–
	A				5EP A	Automatic (Wax type)	X	X	
	A/T		M/T	B	5XP B	Manual	X	–	
	A			5WP B	Automatic (Wax type)	X	–		
	A			5EQ A	Automatic (Wax type)	X	X		
	4G63	M/T	M/T	B	5XR A	Manual	X	–	
				A/T	B	5XR B	Manual	X	–
	Space runner/ Space wagon	4G93	M/T	M/T	C	32-35DIDTA-464	Automatic (Wax type)	X	–
					C	32-35DIDTA-462	Automatic (Wax type)	X	–
				A/T	C	32-35DIDTA-465	Automatic (Wax type)	X	–
C					32-35DIDTA-463	Automatic (Wax type)	X	–	
L300	4G33	M/T	M/T	B	5XJ A	Manual	X	–	
				B	5AJ A	Manual	X	–	
	4G32	M/T	M/T	B	5XJ A	Manual	X	–	
				B	5AJ A	Manual	X	–	
	4G63	M/T	M/T	M/T	B	5XK A	Manual	X	–
					B	5XK A	Manual	X	–

Vehicle model	Engine	Trans- mission	Carburetor				Cold mixture heater		
			Type	Identification No.	Choke type	Fuel cut solenoid			
EXP	L300-4WD	4G63	M/T	B	5XK A	Manual	X	–	
				B	5CK A	Manual	X	–	
	L200	4G32	M/T	B	3XA D	Manual	X	–	
		4G63	M/T	B	1XL D	Manual	X	–	
	L200-4WD	4G63	M/T						
	Pajero/ Montero	4G54	M/T	D	32-35DIDSA-24	Manual	X	–	
				D	32-35DIDSA-26	Manual	X	–	
				A/T	D	32-35DIDSA-24	Manual	X	–
	GCC	Galant (E32A, E33A)	4G37	M/T	A	5AP A	Automatic (Wax type)	X	–
					A/T	A	5AP B	Automatic (Wax type)	X
M/T				A	5AR A	Automatic (Wax type)	X	–	
				A/T	A	5AR B	Automatic (Wax type)	X	–
Space wagon		4G93	M/T	C	32-35DIDTA-460	Automatic (Wax type)	X	–	
				A/T	C	32-35DIDTA-461	Automatic (Wax type)	X	–
L300		4G32	M/T	B	5AJ A	Manual	X	–	
				B	5AZ A	Manual	X	–	
				A/T					
L200		4G63	M/T	B	3AW A	Manual	X	–	
		4G54	M/T	A	5WK A	Automatic (Wax type)	X	–	
L200-4WD		4G63	M/T	B	3AW A	Manual	X	–	
Pajero/ Montero		4G54	M/T	D	32-32DIDSA-25	Manual	X	–	
			A/T						
Hong kong		L300	4G33	M/T	A	7DE A	Automatic (Wax type)	X	–

NOTE

M/T: Manual Transmission
 4WD: Four Wheel Drive
 A/T: Automatic Transmission
 X: Applicable
 –: Not Applicable
 GCC: Gulf Cooperation Council

GENERAL SPECIFICATIONS – 1993 MODELS

Vehicle model	Engine	Transmission	Carburetor				Cold mixture heater	
			Type	Identification No.	Choke type	Fuel cut solenoid		
EC	L300	4G32 (Van)	M/T	A	5E1 B	Automatic (Wax type)	X	–
		4G32 (Truck)	M/T	B	5XD C	Manual	X	–
	4G63	M/T	A	5ED B	Automatic (Wax type)	X	–	
		A/T	A	7EG A	Automatic (Wax type)	X	X	
	L200	4G32	M/T	A	3EX C	Automatic (Wax type)	X	–
		4G63	M/T	A	3EZ C	Automatic (Wax type)	X	X
	L200-4WD	4G63	M/T					
	Australia	L300	4G63	M/T	C	32-35DIDTA-394	Automatic (Wax type)	X
A/T			C	32-35DIDTA-395	Automatic (Wax type)	X	–	
L200		4G54	M/T	C	32-35DIDTA-397	Automatic (Wax type)	X	–
L200-4WD		4G54	M/T	C	32-35DIDTA-396	Automatic (Wax type)	X	–
Pajero/ Montero		4G54	M/T	C	32-35DIDTA-393	Automatic (Wax type)	X	–
EXP	Galant (E52A, E55A)	4G93	M/T	C	32-35DIDTA-468	Automatic (Wax type)	X	–
			A/T	C	32-35DIDTA-469	Automatic (Wax type)	X	–
		4G63	M/T	C	32-35DIDTA-490	Automatic (Wax type)	X	–
				C	32-35-DIDTA-496	Automatic (Wax type)	X	–
			A/T	C	32-35DIDTA-491	Automatic (Wax type)	X	–
				C	32-35-DIDTA-497	Automatic (Wax type)	X	–
	Space runner/ Space wagon	4G93	M/T	C	32-35DIDTA-464	Automatic (Wax type)	X	–
				C	32-35DIDTA-462	Automatic (Wax type)	X	–
		A/T	C	32-35DIDTA-465	Automatic (Wax type)	X	–	
			C	32-35DIDTA-463	Automatic (Wax type)	X	–	

CONVENTIONAL CARB – Specifications

13A-1-11b

Vehicle model	Engine	Trans- mission	Carburetor				Cold mixture heater solenoid	
			Type	Identification No.	Choke type	Fuel cut		
EXP	L300	4G33	M/T	B	5XJ B	Manual	X	–
				B	5AJ B	Manual	X	–
		4G32	M/T	B	5XJ B	Manual	X	–
				B	5AJ B	Manual	X	–
		4G63	M/T	B	5XK C	Manual	X	–
				A/T	B	5CK B	Manual	X
	L300-4WD	4G63	M/T	B	5XK C	Manual	X	–
				B	5CK B	Manual	X	–
	L200	4G32	M/T	B	3XA F	Manual	X	–
		4G63	M/T	B	1XL G	Manual	X	–
	L200-4WD	4G63	M/T					
	Pajero/ Montero	4G54	M/T	D	32-35DIDSA-24	Manual	X	–
				D	32-35DIDSA-26	Manual	X	–
	GCC	Galant (E52A, E55A)	4G93	M/T	C	32-35DIDTA-466	Automatic (Wax type)	X
A/T				C	32-35DIDTA-467	Automatic (Wax type)	X	–
4G63			M/T	C	32-35DIDTA-492	Automatic (Wax type)	X	–
			A/T	C	32-35DIDTA-493	Automatic (Wax type)	X	–
Space wagon		4G93	M/T	C	32-35DIDTA-460	Automatic (Wax type)	X	–
				C	32-35DIDTA-461	Automatic (Wax type)	X	–
L300		4G63	M/T	B	5AZ B	Manual	X	–
			A/T					
L200		4G63	M/T	B	3AW B	Manual	X	–
		4G54	M/T	D	32-35DIDSA-27	Manual	X	–
L200-4WD		4G63	M/T	B	3AW B	Manual	X	–
Pajero/ Montero		4G54	M/T	D	32-35DIDSA-25	Manual	X	–
			A/T					
Hong kong		L300	4G33	M/T	C	7DE A	Automatic (Wax type)	X

NOTE

M/T: Manual Transmission
 4WD: Four Wheel Drive
 A/T: Automatic Transmission

X: Applicable
 –: Not Applicable
 GCC: Gulf Cooperation Council

GENERAL SPECIFICATIONS – 1994 MODELS

Vehicle model	Engine	Transmission	Carburetor				Cold mixture heater	
			Type	Identification No.	Choke type	Fuel cut solenoid		
EC	L300	4G32 (Van)	M/T	A	5EI B	Automatic (Wax type)	X	–
		4G32 (Truck)	M/T	A	5ED B	Automatic (Wax type)	X	–
	4G63	M/T	A	5EE B	Automatic (Wax type)	X	X	
		A/T	A	7EG A	Automatic (Wax type)	X	X	
	L200	4G32	M/T	A	3EX C	Automatic (Wax type)	X	–
		4G63	M/T	A	3EZ C	Automatic (Wax type)	X	X
L200-4WD	4G63	M/T						
Australia	L300	4G63	M/T	C	32-35DIDTA-394	Automatic (Wax type)	X	–
		A/T	C	32-35DIDTA-395	Automatic (Wax type)	X	–	
	L200	4G54	M/T	C	32-35DIDTA-397	Automatic (Wax type)	X	–
	L200-4WD	4G54	M/T	C	32-35DIDTA-396	Automatic (Wax type)	X	–
EXP	Galant (E52A, E55A)	4G93	M/T	C	32-35DIDTA-468	Automatic (Wax type)	X	–
			A/T	C	32-35DIDTA-469	Automatic (Wax type)	X	–
		4G63	M/T	C	32-35DIDTA-490	Automatic (Wax type)	X	–
				C	32-35-DIDTA-496	Automatic (Wax type)	X	–
			A/T	C	32-35DIDTA-491	Automatic (Wax type)	X	–
				C	32-35-DIDTA-497	Automatic (Wax type)	X	–
	Space runner/Space wagon	4G93	M/T	C	32-35DIDTA-510	Automatic (Wax type)	X	–
				C	32-35DIDTA-462	Automatic (Wax type)	X	–
		A/T	C	32-35DIDTA-511	Automatic (Wax type)	X	–	
			C	32-35DIDTA-463	Automatic (Wax type)	X	–	

CONVENTIONAL CARB – Specifications

13A-1-11d

Vehicle model	Engine	Trans- mission	Carburetor				Cold mixture heater	
			Type	Identification No.	Choke type	Fuel cut		
EXP	L300	4G33	M/T	B	5XJ B	Manual	X	–
				B	5AJ B	Manual	X	–
				B	7BH A	Manual	X	–
	4G32	M/T	B	5XJ B	Manual	X	–	
			B	5AJ B	Manual	X	–	
			B	7BH A	Manual	X	–	
	4G63	M/T	M/T	B	5XK C	Manual	X	–
				B	7BJ A	Manual	X	–
			A/T	B	5CK B	Manual	X	–
				B	7BJ A	Manual	X	–
	L300-4WD	4G63	M/T	B	5XK C	Manual	X	–
				B	5CK B	Manual	X	–
				B	7BJ A	Manual	X	–
	L200	4G32	M/T	B	3XA F	Manual	X	–
		4G63	M/T	B	1XL G	Manual	X	–
B				1XL H	Manual	X	–	
L200-4WD	4G63	M/T	B	1XL G	Manual	X	–	
			B	7BK A	Manual	X	–	
Pajero/ Montero	4G54	M/T	D	32-35DIDSA-24	Manual	X	–	
			D	32-35DIDSA-26	Manual	X	–	
			D	32-35DIDSA-28	Manual	X	–	
			C	32-35DIDTA-398	Automatic (Wax type)	X	–	
GCC	Galant (E52A, E55A)	M/T	C	32-35DIDTA-466	Automatic (Wax type)	X	–	
			A/T	C	32-35DIDTA-467	Automatic (Wax type)	X	–
	4G63	M/T	C	32-35DIDTA-492	Automatic (Wax type)	X	–	
			A/T	C	32-35DIDTA-493	Automatic (Wax type)	X	–
	Space wagon	4G93	M/T	C	32-35DIDTA-514	Automatic (Wax type)	X	–
				A/T	C	32-35DIDTA-515	Automatic (Wax type)	X

Vehicle model			Engine	Trans- mission	Carburetor				Cold mixture heater
					Type	Identification No.	Choke type	Fuel cut	
EXP	GCC	L300	4G63	M/T	B	5AZ B	Manual	X	–
				A/T					
	L200	4G63	M/T	B	3AW B	Manual	X	–	
		4G54	M/T	D	32-35DIDSA-27	Manual	X	–	
		L200-4WD	4G63	M/T	B	3AW B	Manual	X	–
	Pajero/ Montero	4G54	M/T	D	32-35DIDSA-25	Manual	X	–	
			A/T						
Hong kong	L300	4G33	M/T	C	7DE A	Automatic (Wax type)	X	–	

NOTE

M/T: Manual Transmission
 4WD: Four Wheel Drive
 A/T: Automatic Transmission

X: Applicable
 –: Not Applicable
 GCC: Gulf Cooperation Council

GENERAL SPECIFICATIONS – 1995 MODELS

Vehicle model	Engine	Trans- mission	Carburetor				Cold mixture heater	
			Type	Identification No.	Choke type	Fuel cut solenoid		
EC	L300	4G63	M/T	C	32-35DIDTA-531	Automatic (Wax type)	X	–
	L200	4G63	M/T	A	3EZ C	Automatic (Wax type)	X	–
Australia	L400	4G63	M/T	C	32-35DIDTA-522	Automatic (Wax type)	X	–
			A/T	C	32-35DIDTA-523	Automatic (Wax type)	X	–
	L300	4G63	M/T	C	32-35DIDTA-534	Automatic (Wax type)	X	–
			A/T	C	32-35DIDTA-525	Automatic (Wax type)	X	–
	L200	4G54	M/T	C	32-35DIDTA-397	Automatic (Wax type)	X	–
				C	32-35DIDTA-396	Automatic (Wax type)	X	–
EXP	Galant (E52A, E55A)	4G93	M/T	C	32-35DIDTA-468	Automatic (Wax type)	X	–
			A/T	C	32-35DIDTA-469	Automatic (Wax type)	X	–
	4G63	M/T	C	32-35DIDTA-490	Automatic (Wax type)	X	–	
			C	32-35DIDTA-496	Automatic (Wax type)	X	–	
			C	32-35DIDTA-498	Automatic (Wax type)	X	–	
			C	32-35DIDTA-562	Automatic (Wax type)	X	–	
			C	32-35DIDTA-564	Automatic (Wax type)	X	–	
			A/T	C	32-35DIDTA-491	Automatic (Wax type)	X	–
			C	32-35DIDTA-497	Automatic (Wax type)	X	–	
			C	32-35DIDTA-499	Automatic (Wax type)	X	–	
			C	32-35DIDTA-563	Automatic (Wax type)	X	–	
			C	32-35DIDTA-565	Automatic (Wax type)	X	–	

Vehicle model	Engine	Transmission	Carburetor				Cold mixture heater		
			Type	Identification No.	Choke type	Fuel cut solenoid			
EXP	Space wagon	M/T	C	32-35DIDTA-510	Automatic (Wax type)	X	–		
			C	32-35DIDTA-530	Automatic (Wax type)	X	–		
			C	32-35DIDTA-555	Automatic (Wax type)	X	–		
			C	32-35DIDTA-557	Automatic (Wax type)	X	–		
		A/T	C	32-35DIDTA-511	Automatic (Wax type)	X	–		
			C	32-35DIDTA-550	Automatic (Wax type)	X	–		
			C	32-35DIDTA-556	Automatic (Wax type)	X	–		
			C	32-35DIDTA-558	Automatic (Wax type)	X	–		
		L400	4G63	M/T	C	32-35DIDTA-537	Automatic (Wax type)	X	–
					C	32-35DIDTA-542	Automatic (Wax type)	X	–
A/T	C			32-35DIDTA-538	Automatic (Wax type)	X	–		
L300	4G92	M/T	D	32-35DIDSA-31	Manual	X	–		
			D	32-35DIDSA-32	Manual	X	–		
	4G63	M/T	D	32-35DIDSA-34	Manual	X	–		
			D	32-35DIDSA-42	Manual	X	–		
L200	4G32	M/T	B	3XA F	Manual	X	–		
			B	7BL A	Manual	X	–		
	4G63	M/T	B	1XL G	Manual	X	–		
			B	1XL H	Manual	X	–		
			B	7BK A	Manual	X	–		
			B	1PL A	Manual	X	–		
			B	1PL B	Manual	X	–		

Vehicle model	Engine	Trans- mission	Carburetor				Cold mixture heater	
			Type	Identification No.	Choke type	Fuel cut solenoid		
EXP	Pajero/ Montero	4G54	M/T	D	32-35DIDSA-24	Manual	X	–
				D	32-35DIDSA-26	Manual	X	–
				D	32-35DIDSA-28	Manual	X	–
GCC	Galant (E52A, E55A)	4G93	M/T	C	32-35DIDTA-466	Automatic (Wax type)	X	–
			A/T	C	32-35DIDTA-467	Automatic (Wax type)	X	–
		4G63	M/T	C	32-35DIDTA-492	Automatic (Wax type)	X	–
			A/T	C	32-35DIDTA-493	Automatic (Wax type)	X	–
	Space wagon	4G93	M/T	C	32-35DIDTA-514	Automatic (Wax type)	X	–
			A/T	C	32-35DIDTA-515	Automatic (Wax type)	X	–
	L400	4G63	M/T	C	32-35DIDTA-520	Automatic (Wax type)	X	–
			A/T	C	32-35DIDTA-521	Automatic (Wax type)	X	–
	L300	4G63	M/T	D	32-35DIDSA-39	Manual	X	–
	L200	4G63	M/T	B	3AW B	Manual	X	–
		4G54	M/T	D	32-35DIDSA-27	Manual	X	–
	Pajero/ Montero	4G54	M/T	D	32-35DIDSA-25	Manual	X	–
A/T								

NOTE

M/T: Manual Transmission

4WD: Four Wheel Drive

A/T: Automatic Transmission

X: Applicable

–: Not Applicable

GCC: Gulf Cooperation Council

GENERAL SPECIFICATIONS – 1996 MODELS

Vehicle model	Engine	Transmission	Carburetor				Cold mixture heater		
			Type	Identification No.	Choke type	Fuel cut solenoid			
Australia	L400	4G63	M/T	C	32-35DIDTA-522	Automatic (Wax type)	X	–	
			A/T	C	32-35DIDTA-523	Automatic (Wax type)	X	–	
	L300	4G63	M/T	C	32-35DIDTA-534	Automatic (Wax type)	X	–	
				C	32-35DIDTA-394	Automatic (Wax type)	X	–	
			A/T	C	32-35DIDTA-535	Automatic (Wax type)	X	–	
				C	32-35DIDTA-395	Automatic (Wax type)	X	–	
	L200	4G54	M/T	C	32-35DIDTA-397	Automatic (Wax type)	X	–	
				C	32-35DIDTA-396	Automatic (Wax type)	X	–	
	EXP	Galant (E52A, E55A)	4G93	M/T	C	32-35DIDTA-468	Automatic (Wax type)	X	–
				A/T	C	32-35DIDTA-469	Automatic (Wax type)	X	–
4G63		M/T	C	32-35DIDTA-490	Automatic (Wax type)	X	–		
			C	32-35DIDTA-496	Automatic (Wax type)	X	–		
			C	32-35DIDTA-498	Automatic (Wax type)	X	–		
			C	32-35DIDTA-562	Automatic (Wax type)	X	–		
			C	32-35DIDTA-564	Automatic (Wax type)	X	–		
			A/T	C	32-35DIDTA-491	Automatic (Wax type)	X	–	
			C	32-35DIDTA-497	Automatic (Wax type)	X	–		
			C	32-35DIDTA-499	Automatic (Wax type)	X	–		
			C	32-35DIDTA-563	Automatic (Wax type)	X	–		
			C	32-35DIDTA-565	Automatic (Wax type)	X	–		

CONVENTIONAL CARB – Specifications

13A-1-11j

Vehicle model	Engine	Trans- mission	Carburetor				Cold mixture heater		
			Type	Identification No.	Choke type	Fuel cut solenoid			
EXP	Space wagon	M/T	C	32-35DIDTA-510	Automatic (Wax type)	X	-		
			C	32-35DIDTA-530	Automatic (Wax type)	X	-		
			C	32-35DIDTA-555	Automatic (Wax type)	X	-		
			C	32-35DIDTA-557	Automatic (Wax type)	X	-		
		A/T	C	32-35DIDTA-511	Automatic (Wax type)	X	-		
		C	32-35DIDTA-550	Automatic (Wax type)	X	-			
		C	32-35DIDTA-556	Automatic (Wax type)	X	-			
		C	32-35DIDTA-558	Automatic (Wax type)	X	-			
		L400	4G63	M/T	C	32-35DIDTA-537	Automatic (Wax type)	X	-
					C	32-35DIDTA-542	Automatic (Wax type)	X	-
C	32-35DIDTA-551				Automatic (Wax type)	X	-		
C	32-35DIDTA-552				Automatic (Wax type)	X	-		
A/T	C	32-35DIDTA-538	Automatic (Wax type)	X	-				
L300	4G92	M/T	D	32-35DIDSA-31	Manual	X	-		
			D	32-35DIDSA-32	Manual	X	-		
	4G63	M/T	D	32-35DIDSA-34	Manual	X	-		
			D	32-35DIDSA-42	Manual	X	-		
L200	4G32	M/T	B	3XA F	Manual	X	-		
			B	7BL A	Manual	X	-		
	4G63	M/T	B	1XL G	Manual	X	-		
			B	1XL H	Manual	X	-		
			B	7BK A	Manual	X	-		
			B	1PL A	Manual	X	-		
			B	1PL B	Manual	X	-		
			B	5XK C	Manual	X	-		

Vehicle model	Engine	Transmission	Carburetor				Cold mixture heater		
			Type	Identification No.	Choke type	Fuel cut solenoid			
EXP	Pajero/ Montero	4G54	M/T	D	32-35DIDSA-24	Manual	X	-	
				D	32-35DIDSA-26	Manual	X	-	
				D	32-35DIDSA-28	Manual	X	-	
GCC	Galant (E52A, E55A)	4G93	M/T	C	32-35DIDTA-466	Automatic (Wax type)	X	-	
				A/T	32-35DIDTA-467	Automatic (Wax type)	X	-	
		4G63	M/T	C	32-35DIDTA-492	Automatic (Wax type)	X	-	
					32-35DIDTA-493	Automatic (Wax type)	X	-	
		Space wagon	4G93	M/T	C	32-35DIDTA-514	Automatic (Wax type)	X	-
						32-35DIDTA-515	Automatic (Wax type)	X	-
	L400	4G63	M/T	C	32-35DIDTA-520	Automatic (Wax type)	X	-	
					32-35DIDTA-521	Automatic (Wax type)	X	-	
	L300	4G63	M/T	D	32-35DIDSA-39	Manual	X	-	
					5AZ B	Manual	X	-	
	L200	4G63	M/T	B	3AW B	Manual	X	-	
					4G54	M/T	D	32-35DIDSA-27	Manual
Pajero/ Montero	4G54	M/T	D	32-35DIDSA-25	Manual	X	-		
				A/T					

NOTE

M/T: Manual Transmission
 4WD: Four Wheel Drive
 A/T: Automatic Transmission
 X: Applicable
 -: Not Applicable
 GCC: Gulf Cooperation Council

GENERAL SPECIFICATIONS – 1997 MODELS

Vehicle model	Engine	Transmission	Carburetor				Cold mixture heater				
			Type	Identification No.	Choke type	Fuel cut solenoid					
Australia	L400	4G63	M/T	C	32-35DIDTA-522	Automatic (Wax type)	X	--			
			A/T	C	32-35DIDTA-523	Automatic (Wax type)	X	--			
	L300	4G63	M/T	C	32-35DIDTA-534	Automatic (Wax type)	X	--			
				C	32-35DIDTA-394	Automatic (Wax type)	X	--			
			A/T	C	32-35DIDTA-535	Automatic (Wax type)	X	--			
				C	32-35DIDTA-395	Automatic (Wax type)	X	--			
EXP	Space wagon	4G93	M/T	C	32-35DIDTA-510	Automatic (Wax type)	X	--			
				C	32-35DIDTA-530	Automatic (Wax type)	X	--			
				C	32-35DIDTA-555	Automatic (Wax type)	X	--			
			A/T	C	32-35DIDTA-511	Automatic (Wax type)	X	--			
				C	32-35DIDTA-550	Automatic (Wax type)	X	--			
				C	32-35DIDTA-556	Automatic (Wax type)	X	--			
	L400	4G63	M/T	C	32-35DIDTA-537	Automatic (Wax type)	X	--			
				C	32-35DIDTA-542	Automatic (Wax type)	X	--			
				C	32-35DIDTA-551	Automatic (Wax type)	X	--			
				C	32-35DIDTA-552	Automatic (Wax type)	X	--			
			A/T	C	32-35DIDTA-538	Automatic (Wax type)	X	--			
				L300	4G92	M/T	D	32-35DIDSA-31	Manual	X	--
							D	32-35DIDSA-32	Manual	X	--
					4G63	M/T	D	32-35DIDSA-34	Manual	X	--
D	32-35DIDSA-42	Manual	X				--				

Vehicle model	Engine	Transmission	Carburetor				Cold mixture heater	
			Type	Identification No.	Choke type	Fuel cut solenoid		
EXP	L200	4G63	M/T	B	1XL G	Manual	X	-
				B	1XL H	Manual	X	-
				B	7BK A	Manual	X	-
				B	1PL A	Manual	X	-
				B	1PL B	Manual	X	-
GCC	Space wagon	4G93	M/T	C	32-35DIDTA-514	Automatic (Wax type)	X	-
			A/T	C	32-35DIDTA-515	Automatic (Wax type)	X	-
	L400	4G63	M/T	C	32-35DIDTA-520	Automatic (Wax type)	X	-
	L300	4G63	M/T	D	32-35DIDSA-39	Manual	X	-
				D	32-35DIDSA-45	Manual	X	-
	L200	4G63	M/T	B	3AW B	Manual	X	-
		4G54	M/T	D	32-35DIDSA-27	Manual	X	-

NOTE

M/T: Manual Transmission

4WD: Four Wheel Drive

A/T: Automatic Transmission

X: Applicable

-: Not Applicable

GCC: Gulf Cooperation Council

GENERAL SPECIFICATIONS – 1998 MODELS

Vehicle model	Engine	Transmission	Carburetor				Cold mixture heater		
			Type	Identification No.	Choke type	Fuel cut solenoid			
Australia	L300	4G63	M/T	C	32-35DIDTA-534	Automatic (Wax type)	X	--	
			A/T	C	32-35DIDTA-535	Automatic (Wax type)	X	--	
EXP	Space wagon	4G93	M/T	C	32-35DIDTA-510	Automatic (Wax type)	X	--	
				C	32-35DIDTA-514	Automatic (Wax type)	X	--	
			A/T	C	32-35DIDTA-511	Automatic (Wax type)	X	--	
				C	32-35DIDTA-515	Automatic (Wax type)	X	--	
	Pajero/ Montero	4G64	M/T	C	32-35DIDTA-548	Automatic (Wax type)	X	--	
	L300	4G63	M/T	D	D	32-35DIDSA-34	Automatic (Wax type)	X	--
					D	32-35DIDSA-39	Automatic (Wax type)	X	--
				A/T	D	32-35DIDSA-45	Automatic (Wax type)	X	--
	L400	4G63	M/T	C	C	32-35DIDTA-537	Automatic (Wax type)	X	--
					C	32-35DIDTA-538	Automatic (Wax type)	X	--
Space Gear	4G63	M/T	C	C	32-35DIDTA-537	Automatic (Wax type)	X	--	
				A/T	C	32-35DIDTA-538	Automatic (Wax type)	X	--

NOTE

M/T: Manual Transmission
 4WD: Four Wheel Drive
 A/T: Automatic Transmission
 X: Applicable
 -: Not Applicable
 GCC: Gulf Cooperation Council

CARBURETOR SPECIFICATIONS – AISAN TYPE

Carburetor identification No.	Throttle bore mm (in.)		Main jet		Slow jet or pilot jet		Power jet or enrichment jet	Float type	Dash pot	Throttle position sensor	Bowl vent valve
	P	S	P	S	P	S					
1PL A	28 (1.102)	32 (1.260)	#112	#165	#52	#60	#55	Y	–	–	–
1PL B	28 (1.102)	32 (1.260)	#112	#165	#52	#60	#55	Y	–	–	–
1XL D	28 (1.102)	32 (1.260)	#112	#165	#52	#60	#55	Y	–	–	–
1XL G	28 (1.102)	32 (1.260)	#112	#165	#52	#60	#55	Y	–	–	–
1XL H	28 (1.102)	32 (1.260)	#112	#165	#52	#60	#55	Y	–	–	–
3AT A	28 (1.102)	32 (1.260)	#94	#150	#51	#70	#50	Z	Conventional type	–	–
3AW A	28 (1.102)	32 (1.260)	#107	#185	#52	#90	#47	Z	–	–	–
3AW B	28 (1.102)	32 (1.260)	#107	#185	#52	#90	#47	Z	–	–	–
3ET A	28 (1.102)	32 (1.260)	#94	#150	#51	#70	#50	Z	CV type	–	–
3ET B	28 (1.102)	32 (1.260)	#94	#150	#51	#70	#50	Z	CV type	–	–
3EU A	28 (1.102)	32 (1.260)	#94	#150	#51	#70	#50	Z	Conventional type	–	–
3EU B	28 (1.102)	32 (1.260)	#94	#150	#51	#70	#50	Z	Conventional type	–	–
3EW C	28 (1.102)	32 (1.260)	#107	#185	#52	#90	#47	Z	CV type	–	–
3EX A	28 (1.102)	32 (1.260)	#96	#153	#50	#90	#50	Z	CV type	–	–
3EX C	28 (1.102)	32 (1.260)	#96	#153	#50	#90	#50	Z	CV type	–	–
3EZ A	28 (1.102)	32 (1.260)	#106	#185	#53	#100	#47	Z	CV type	–	–
3EZ C	28 (1.102)	32 (1.260)	#106	#185	#53	#100	#47	Z	CV type	–	–
3WT C	28 (1.102)	32 (1.260)	#95	#150	#51	#70	#50	Z	Conventional type	–	–
3WT D	28 (1.102)	32 (1.260)	#95	#150	#51	#70	#50	Z	Conventional type	–	–
3XA D	28 (1.102)	32 (1.260)	#100	#190	#50	#60	#40	Y	–	–	–
3XA F	28 (1.102)	32 (1.260)	#100	#190	#50	#60	#40	Y	–	–	–

Carburetor identi- fication No.	Throttle bore mm (in.)		Main jet		Slow jet or pilot jet		Power jet or enrichment jet	Float type	Dash pot	Throttle position sensor	Bowl vent valve
	P	S	P	S	P	S					
3XT B	28 (1.102)	32 (1.260)	#95	#150	#51	#70	#50	Z	Conventional type	–	–
3XW C	28 (1.102)	32 (1.260)	#107	#185	#52	#90	#47	Z	Conventional type	–	–
5AC B	28 (1.102)	32 (1.260)	#101	#165	#47	#100	#44	Z	Conventional type	–	–
5AC C	28 (1.102)	32 (1.260)	#101	#165	#47	#100	#44	Z	Conventional type	–	–
5AJ A	28 (1.102)	32 (1.260)	#100	#165	#52	#90	#55	Z	–	–	–
5AJ B	28 (1.102)	32 (1.260)	#100	#165	#52	#90	#55	Z	–	–	–
5AP A	28 (1.102)	32 (1.260)	#101	#174	#47	#100	#44	Z	Conventional type	–	–
5AP B	28 (1.102)	32 (1.260)	#101	#174	#47	#100	#44	Z	Conventional type	X	–
5AR A	28 (1.102)	32 (1.260)	#107	#185	#52	#90	#47	Z	Conventional type	–	–
5AR B	28 (1.102)	32 (1.260)	#107	#185	#52	#90	#47	Z	Conventional type	X	–
5AZ A	28 (1.102)	32 (1.260)	#107	#190	#50	#100	#47	Z	–	–	–
5AZ B	28 (1.102)	32 (1.260)	#107	#190	#50	#100	#47	Z	–	–	–
5CK A	28 (1.102)	32 (1.260)	#110	#190	#52	#90	#40	Z	–	–	–
5CK B	28 (1.102)	32 (1.260)	#110	#190	#52	#90	#40	Z	–	–	–
5EC A	28 (1.102)	32 (1.260)	#101	#165	#47	#100	#44	Z	CV type	–	–
5EC B	28 (1.102)	32 (1.260)	#101	#165	#47	#100	#44	Z	CV type	–	–
5ED A	28 (1.102)	32 (1.260)	#98	#165	#52	#90	#55	Z	CV type	–	–
5ED B	28 (1.102)	32 (1.260)	#98	#165	#52	#90	#55	Z	CV type	–	–
5EE A	28 (1.102)	32 (1.260)	#107	#190	#50	#100	#47	Z	CV type	–	–
5EE B	28 (1.102)	32 (1.260)	#107	#190	#50	#100	#47	Z	CV type	–	–
5EI A	28 (1.102)	32 (1.260)	#100	#165	#52	#90	#55	Z	CV type	–	–
5EI B	28 (1.102)	32 (1.260)	#100	#165	#52	#90	#55	Z	CV type	–	–

13A-1-14

CONVENTIONAL CARB – Specifications

Carburetor identi- fication No.	Throttle bore mm (in.)		Main jet		Slow jet or pilot jet		Power jet or enrichment jet	Float type	Dash pot	Throttle position sensor	Bowl vent valve
	P	S	P	S	P	S					
5EN A	28 (1.102)	32 (1.260)	#101	#165	#47	#100	#44	Z	Conventional type	–	–
5EO A	28 (1.102)	32 (1.260)	#94	#159	#50	#90	#50	Z	Conventional type	–	–
5EP A	28 (1.102)	32 (1.260)	#101	#174	#47	#100	#44	Z	Conventional type	–	–
5EQ A	28 (1.102)	32 (1.260)	#101	#174	#47	#100	#44	Z	Conventional type	X	–
5EU A	28 (1.102)	32 (1.260)	#95	#144	#51	#100	#50	Z	CV type	–	–
5EU B	28 (1.102)	32 (1.260)	#95	#144	#51	#100	#50	Z	CV type	–	–
5EV A	28 (1.102)	32 (1.260)	#95	#144	#51	#100	#50	Z	Conventional type	–	–
5EV B	28 (1.102)	32 (1.260)	#95	#144	#51	#100	#50	Z	Conventional type	–	–
5WK A	28 (1.102)	32 (1.260)	#110	#190	#52	#90	#40	Z	–	–	–
5WO A	28 (1.102)	32 (1.260)	#94	#159	#50	#90	#50	Z	Conventional type	–	–
5WP A	28 (1.102)	32 (1.260)	#101	#174	#47	#100	#44	Z	Conventional type	–	–
5WP B	28 (1.102)	32 (1.260)	#101	#174	#47	#100	#44	Z	Conventional type	X	–
5WU A	28 (1.102)	32 (1.260)	#95	#144	#51	#100	#50	Z	CV type	–	–
5WU B	28 (1.102)	32 (1.260)	#95	#144	#51	#100	#50	Z	Conventional type	–	–
5XC C	28 (1.102)	32 (1.260)	#101	#165	#47	#100	#44	Z	Conventional type	–	–
5XC D	28 (1.102)	32 (1.260)	#101	#165	#47	#100	#44	Z	Conventional type	–	–
5XD C	28 (1.102)	32 (1.260)	#98	#159	#52	#90	#55	Z	–	–	–
5XJ A	28 (1.102)	32 (1.260)	#100	#165	#52	#90	#55	Z	–	–	–
5XJ B	28 (1.102)	32 (1.260)	#100	#165	#52	#90	#55	Z	–	–	–
5XK A	28 (1.102)	32 (1.260)	#110	#190	#52	#90	#40	Z	–	–	–
5XK C	28 (1.102)	32 (1.260)	#110	#190	#52	#90	#40	Z	–	–	–
5XO A	28 (1.102)	32 (1.260)	#94	#159	#50	#90	#50	Z	–	–	–

Carburetor identifi- cation No.	Throttle bore mm (in.)		Main jet		Slow jet or pilot jet		Power jet or enrichment jet	Float type	Dash pot	Throttle position sensor	Bowl vent valve
	P	S	P	S	P	S					
5XO B	28 (1.102)	32 (1.260)	#94	#159	#50	#90	#50	Z	Conventional type	X	–
5XP A	28 (1.102)	32 (1.260)	#101	#174	#47	#100	#44	Z	–	–	–
5XP B	28 (1.102)	32 (1.260)	#101	#174	#47	#100	#44	Z	Conventional type	X	–
5XR A	28 (1.102)	32 (1.260)	#107	#185	#52	#90	#47	Z	–	–	–
5XR B	28 (1.102)	32 (1.260)	#107	#185	#52	#90	#47	Z	Conventional type	X	–
5XU A	28 (1.102)	32 (1.260)	#95	#144	#51	#100	#50	Z	CV type	–	–
5XU B	28 (1.102)	32 (1.260)	#95	#144	#51	#100	#50	Z	Conventional type	–	–
7BH A	28 (1.102)	32 (1.260)	#104	#165	#55	#90	#55	Z	–	–	–
7BJ A	28 (1.102)	32 (1.260)	#114	#190	#55	#90	#40	Z	–	–	–
7BK A	28 (1.102)	32 (1.260)	#116	#165	#55	#60	#55	Y	–	–	–
7BL A	28 (1.102)	32 (1.260)	#104	#190	#53	#60	#40	Y	–	–	–
7EG A	28 (1.102)	32 (1.260)	#107	#190	#50	#100	#47	Z	–	–	–
7DE A	28 (1.102)	32 (1.260)	#104	#165	#52	#90	#40	Z	–	–	–

NOTE

P: Primary
 S: Secondary
 CV: Controlled Vacuum
 X: Applicable
 –: Not Applicable

Intentionally blank

CARBURETOR SPECIFICATIONS – MIKUNI TYPE

Carburetor identification No.	Throttle bore mm (in.)		Main jet		Slow jet or pilot jet		Power jet or enrichment jet	Dash pot	Throttle position sensor	Bowl vent valve
	P	S	P	S	P	S				
30-32DIDTA-342	30 (1.181)	32 (1.260)	#87.5	#155	#42.5	#50	#42.5	–	–	X
30-32DIDTA-343	30 (1.181)	32 (1.260)	#87.5	#155	#42.5	#50	#42.5	–	–	X
32-35DIDSA-20	32 (1.260)	35 (1.378)	#113.8	#220	#50	#67.5	#70	–	–	–
32-35DIDSA-21	32 (1.260)	35 (1.378)	#113.8	#220	#50	#67.5	#70	–	–	–
32-35DIDSA-22	32 (1.260)	35 (1.378)	#113.8	#220	#50	#67.5	#70	–	–	–
32-35DIDSA-23	32 (1.260)	35 (1.378)	#113.8	#220	#50	#67.5	#70	CV type	–	–
32-35DIDSA-24	32 (1.260)	35 (1.378)	#113.8	#220	#50	#67.5	#70	–	–	–
32-35DIDSA-25	32 (1.260)	35 (1.378)	#113.8	#220	#50	#67.5	#70	–	–	–
32-35DIDSA-26	32 (1.260)	35 (1.378)	#113.8	#220	#50	#67.5	#70	–	–	–
32-35DIDSA-27	32 (1.260)	35 (1.378)	#113.8	#220	#50	#67.5	#70	CV type	–	–
32-35DIDSA-28	32 (1.260)	35 (1.378)	#116.3	#220	#50	#67.5	#70	–	–	–
32-35DIDSA-31	32 (1.260)	35 (1.378)	#103.8	#185	#41.3	#70	#60	–	–	X
32-35DIDSA-32	32 (1.260)	35 (1.378)	#103.8	#185	#41.3	#70	#60	–	–	X
32-35DIDSA-34	32 (1.260)	35 (1.378)	#113.8	#165	#43.8	#70	#70	–	–	X
32-35DIDSA-39	32 (1.260)	35 (1.378)	#111.3	#167.5	#41.3	#70	#82.5	–	–	X
32-35DIDSA-42	32 (1.260)	35 (1.378)	#113.8	#165	#43.8	#70	#70	–	–	X
32-35DIDSA-45	32 (1.260)	35 (1.378)	#111.3	#167.5	#41.3	#70	#82.5	DI type	–	–
32-35DIDTA-378	32 (1.260)	35 (1.378)	#112.5	#195	#50	#67.5	#70	Conventional type	–	–
32-35DIDTA-380	32 (1.260)	35 (1.378)	#113.8	#220	#50	#67.5	#70	–	–	X
32-35DIDTA-382	32 (1.260)	35 (1.378)	#107.5	#175	#52.5	#60	#60	Conventional type	–	X
32-35DIDTA-383	32 (1.260)	35 (1.378)	#107.5	#175	#52.5	#60	#60	–	–	X

13A-1-16

CONVENTIONAL CARB – Specifications

Carburetor identification No.	Throttle bore mm (in.)		Main jet		Slow jet or pilot jet		Power jet or enrichment jet	Dash pot	Throttle position sensor	Bowl vent valve
	P	S	P	S	P	S				
32-35DIDTA-386	32 (1.260)	35 (1.378)	#106.3	#165	#52.5	#60	#60	–	–	X
32-35DIDTA-387	32 (1.260)	35 (1.378)	#106.3	#165	#52.5	#60	#60	–	–	X
32-35DIDTA-388	32 (1.260)	35 (1.378)	#113.8	#195	#50	#67.5	#70	–	–	X
32-35DIDTA-389	32 (1.260)	35 (1.378)	#111.3	#220	#50	#67.5	#70	Conventional type	–	–
32-35DIDTA-391	32 (1.260)	35 (1.378)	#113.8	#230	#50	#67.5	#70	Conventional type	–	X
32-35DIDTA-392	32 (1.260)	35 (1.378)	#113.8	#230	#50	#67.5	#70	–	X	X
32-35DIDTA-393	32 (1.260)	35 (1.378)	#113.8	#220	#50	#67.5	#70	–	–	X
32-35DIDTA-394	32 (1.260)	35 (1.378)	#106.3	#165	#52.5	#60	#60	–	–	X
32-35DIDTA-395	32 (1.260)	35 (1.378)	#106.3	#165	#52.5	#60	#60	–	–	X
32-35DIDTA-396	32 (1.260)	35 (1.378)	#112.5	#195	#50	#67.5	#70	CV type	–	–
32-35DIDTA-397	32 (1.260)	35 (1.378)	#113.8	#195	#50	#67.5	#70	–	–	–
32-35DIDTA-398	32 (1.260)	35 (1.378)	#112.5	#250	#50	#67.5	#70	CV type	–	–
32-35DIDTA-460	32 (1.260)	35 (1.378)	#98.8	#185	#42.5	#70	#40	Conventional type	–	–
32-35DIDTA-461	32 (1.260)	35 (1.378)	#98.8	#185	#42.5	#70	#40	Conventional type	X	–
32-35DIDTA-462	32 (1.260)	35 (1.378)	#98.8	#185	#42.5	#70	#40	Conventional type	–	–
32-35DIDTA-463	32 (1.260)	35 (1.378)	#98.8	#185	#42.5	#70	#40	Conventional type	X	–
32-35DIDTA-464	32 (1.260)	35 (1.378)	#98.8	#185	#42.5	#70	#40	Conventional type	–	–
32-35DIDTA-465	32 (1.260)	35 (1.378)	#98.8	#185	#42.5	#70	#40	Conventional type	X	–
32-35DIDTA-466	32 (1.260)	35 (1.378)	#100	#180	#43.8	#70	#45	–	–	–
32-35DIDTA-467	32 (1.260)	35 (1.378)	#100	#180	#43.8	#70	#45	Conventional type	X	–
32-35DIDTA-468	32 (1.260)	35 (1.378)	#100*1 #101.3*2	#180	#43.8	#70	#45	–	–	–
32-35DIDTA-469	32 (1.260)	35 (1.378)	#100*1 #101.3*2	#180	#43.8	#70	#45	Conventional type	X	–

CONVENTIONAL CARB – Specifications

13A-1-16a

Carburetor identification No.	Throttle bore mm (in.)		Main jet		Slow jet or pilot jet		Power jet or enrich- ment jet	Dash pot	Throttle position sensor	Bowl vent valve
	P	S	P	S	P	S				
32-35DIDTA-490	32 (1.260)	35 (1.378)	#113.8	#210	#41.3	#70	#60	-	-	-
32-35DIDTA-491	32 (1.260)	35 (1.378)	#113.8	#210	#41.3	#70	#60	Conventional type	X	-
32-35DIDTA-492	32 (1.260)	35 (1.378)	#113.8	#210	#41.3	#70	#60	-	-	-
32-35DIDTA-493	32 (1.260)	35 (1.378)	#113.8	#210	#41.3	#70	#60	Conventional type	X	-
32-35DIDTA-496	32 (1.260)	35 (1.378)	#113.8	#210	#41.3	#70	#60	-	-	-
32-35DIDTA-497	32 (1.260)	35 (1.378)	#113.8	#210	#41.3	#70	#60	Conventional type	X	-
32-35DIDTA-498	32 (1.260)	35 (1.378)	#113.8	#210	#41.3	#70	#60	-	-	-
32-35DIDTA-499	32 (1.260)	35 (1.378)	#113.8	#210	#41.3	#70	#60	X	X	-
32-35DIDTA-510	32 (1.260)	35 (1.378)	#100* ³ #101.3* ⁴	#180	#43.8	#70	#45	-	-	-
32-35DIDTA-511	32 (1.260)	35 (1.378)	#100* ³ #101.3* ⁴	#180	#43.8	#70	#45	Conventional type	X	-
32-35DIDTA-514	32 (1.260)	35 (1.378)	#100	#180	#43.8	#70	#45	-	-	-
32-35DIDTA-515	32 (1.260)	35 (1.378)	#100	#180	#43.8	#70	#45	Conventional type	X	-
32-35DIDTA-520	32 (1.260)	35 (1.378)	#111.3	#162.5	#41.3	#70	#82.5	-	-	X
32-35DIDTA-521	32 (1.260)	35 (1.378)	#111.3	#162.5	#41.3	#70	#82.5	X	-	X
32-35DIDTA-522	32 (1.260)	35 (1.378)	#113.8	#162.5	#43.8	#70	#70	-	-	X
32-35DIDTA-523	32 (1.260)	35 (1.378)	#113.8	#162.5	#43.8	#70	#70	X	-	X
32-35DIDTA-530	32 (1.260)	35 (1.378)	#101* ³ #101.3* ⁴	#180	#43.8	#70	#45	-	-	-
32-35DIDTA-531	32 (1.260)	35 (1.378)	#113.8	#162.5	#43.8	#70	#70	-	-	X
32-35DIDTA-534	32 (1.260)	35 (1.378)	#113.8	#165	#43.8	#70	#70	-	-	X
32-35DIDTA-535	32 (1.260)	35 (1.378)	#113.8	#165	#43.8	#70	#70	X	-	X
32-35DIDTA-537	32 (1.260)	35 (1.378)	#113.8	#162.5	#43.8	#70	#70	-	-	X

Carburetor identification No.	Throttle bore mm (in.)		Main jet		Slow jet or pilot jet		Power jet or enrich- ment jet	Dash pot	Throttle position sensor	Bow vent valve
	P	S	P	S	P	S				
32-35DIDTA-538	32 (1.260)	35 (1.378)	#113.8	#162.5	#43.8	#70	#70	X	-	X
32-35DIDTA-542	32 (1.260)	35 (1.378)	#113.8	#162.5	#43.8	#70	#70	-	-	X
32-35DIDTA-548	32 (1.260)	35 (1.378)	#111.3	#250	#50	#95	#70	-	-	-
32-35DIDTA-550	32 (1.260)	35 (1.378)	#100* ³ #101.3* ⁴	#180	#43.8	#70	#45	X	X	-
32-35DIDTA-551	32 (1.260)	35 (1.378)	#113.8	#162.5	#43.8	#70	#70	-	-	X
32-35DIDTA-552	32 (1.260)	35 (1.378)	#113.8	#162.5	#43.8	#70	#70	-	-	X
32-35DIDTA-555	32 (1.260)	35 (1.378)	#100* ³ #101.3* ⁴	#180	#43.8	#70	#45	-	-	-
32-35DIDTA-556	32 (1.260)	35 (1.378)	#100* ³ #101.3* ⁴	#180	#43.8	#70	#45	X	X	-
32-35DIDTA-557	32 (1.260)	35 (1.378)	#100* ³ #101.3* ⁴	#180	#43.8	#70	#45	-	-	-
32-35DIDTA-558	32 (1.260)	35 (1.378)	#100* ³ #101.3* ⁴	#180	#43.8	#70	#45	X	X	-
32-35DIDTA-562	32 (1.260)	35 (1.378)	#113.8	#210	#41.3	#70	#60	-	-	-
32-35DIDTA-563	32 (1.260)	35 (1.378)	#113.8	#210	#41.3	#70	#60	X	X	-
32-35DIDTA-564	32 (1.260)	35 (1.378)	#113.8	#210	#41.3	#70	#60	-	-	-
32-35DIDTA-565	32 (1.260)	35 (1.378)	#113.8	#210	#41.3	#70	#60	X	X	-

NOTE

P: Primary

S: Secondary

CV: Controlled Vacuum

X: Applicable

-: Not Applicable

*1: Vehicles produced up to Oct. 1994.

*2: Vehicles produced from Nov. 1994.

*3: Vehicles produced up to Nov. 1994.

*4: Vehicles produced from Dec. 1994.

SERVICE SPECIFICATIONS

CARBURETOR – AISAN TYPE

Carburetor identi- fication No.	Slow-cut solenoid valve resistance [at 20°C (68°F)] Ω	Throttle position sensor resistance kΩ	Fast idle opening mm (in.)	Float level adjustment	
				Needle valve to float lever clearance mm (in.)	Float to air horn clearance mm (in.)
1PL A	Approx. 90	–	1.31 – 1.43 (0.052 – 0.056)	1.5 – 1.7 (0.059 – 0.067)	Approx. 8.0 (0.31)
1PL B	Approx. 90	–	1.31 – 1.43 (0.052 – 0.056)	1.5 – 1.7 (0.059 – 0.067)	Approx. 8.0 (0.31)
1XL D	Approx. 90	–	1.31 – 1.43 (0.052 – 0.056)	1.5 – 1.7 (0.059 – 0.067)	Approx. 8.0 (0.31)
1XL G	Approx. 90	–	1.31 – 1.43 (0.052 – 0.056)	1.5 – 1.7 (0.059 – 0.067)	Approx. 8.0 (0.31)
1XL H	Approx. 90	–	1.31 – 1.43 (0.052 – 0.056)	1.5 – 1.7 (0.059 – 0.067)	Approx. 8.0 (0.31)
3AT A	Approx. 90	–	0.52 – 0.60 (0.020 – 0.024)	1.5 – 1.7 (0.059 – 0.067)	Approx. 7.4 (0.30)
3AW A	Approx. 90	–	1.31 – 1.43 (0.052 – 0.056)	1.5 – 1.7 (0.059 – 0.067)	Approx. 7.4 (0.30)
3AW B	Approx. 90	–	1.31 – 1.43 (0.052 – 0.056)	1.5 – 1.7 (0.059 – 0.067)	Approx. 7.4 (0.30)
3ET A	Approx. 90	–	0.52 – 0.60 (0.020 – 0.024)	1.5 – 1.7 (0.059 – 0.067)	Approx. 7.4 (0.30)
3ET B	Approx. 90	–	0.48 – 0.56 (0.019 – 0.022)	1.5 – 1.7 (0.059 – 0.067)	Approx. 7.4 (0.30)
3EU A	Approx. 90	–	0.56 – 0.64 (0.022 – 0.025)	1.5 – 1.7 (0.059 – 0.067)	Approx. 7.4 (0.30)
3EU B	Approx. 90	–	0.52 – 0.60 (0.020 – 0.024)	1.5 – 1.7 (0.059 – 0.067)	Approx. 7.4 (0.30)
3EW C	Approx. 90	–	0.72 – 0.81 (0.028 – 0.032)	1.5 – 1.7 (0.059 – 0.067)	Approx. 7.4 (0.30)
3EX A	Approx. 90	–	0.56 – 0.64 (0.022 – 0.025)	1.5 – 1.7 (0.059 – 0.067)	Approx. 7.4 (0.30)
3EX C	Approx. 90	–	0.56 – 0.64 (0.022 – 0.025)	1.5 – 1.7 (0.059 – 0.067)	Approx. 7.4 (0.30)
3EZ A	Approx. 90	–	0.72 – 0.81 (0.028 – 0.032)	1.5 – 1.7 (0.059 – 0.067)	Approx. 7.4 (0.30)
3EZ C	Approx. 90	–	0.72 – 0.81 (0.028 – 0.032)	1.5 – 1.7 (0.059 – 0.067)	Approx. 7.4 (0.30)
3WT C	Approx. 90	–	0.52 – 0.60 (0.020 – 0.024)	1.5 – 1.7 (0.059 – 0.067)	Approx. 7.4 (0.30)
3WT D	Approx. 90	–	0.56 – 0.64 (0.022 – 0.025)	1.5 – 1.7 (0.059 – 0.067)	Approx. 7.4 (0.30)
3XA D	Approx. 90	–	1.20 – 1.31 (0.047 – 0.052)	1.5 – 1.7 (0.059 – 0.067)	Approx. 8.0 (0.31)

Carburetor identi- fication No.	Slow-cut solenoid valve resistance [at 20°C (68°F)] Ω	Throttle position sensor resistance kΩ	Fast idle opening mm (in.)	Float level adjustment	
				Needle valve to float lever clearance mm (in.)	Float to air horn clearance mm (in.)
3XA F	Approx. 90	–	1.20 – 1.31 (0.047 – 0.052)	1.5 – 1.7 (0.059 – 0.067)	Approx. 8.0 (0.31)
3XT B	Approx. 90	–	1.10 – 1.20 (0.043 – 0.047)	1.5 – 1.7 (0.059 – 0.067)	Approx. 7.4 (0.30)
3XW C	Approx. 90	–	1.31 – 1.43 (0.052 – 0.056)	1.5 – 1.7 (0.059 – 0.067)	Approx. 7.4 (0.30)
5AC B	Approx. 90	–	1.31 – 1.43 (0.052 – 0.056)	1.5 – 1.7 (0.059 – 0.067)	Approx. 7.4 (0.30)
5AC C	Approx. 90	–	1.43 – 1.54 (0.056 – 0.061)	1.5 – 1.7 (0.059 – 0.067)	Approx. 7.4 (0.30)
5AJ A	Approx. 90	–	1.20 – 1.31 (0.047 – 0.052)	1.5 – 1.7 (0.059 – 0.067)	Approx. 7.4 (0.30)
5AJ B	Approx. 90	–	1.20 – 1.31 (0.047 – 0.052)	1.5 – 1.7 (0.059 – 0.067)	Approx. 7.4 (0.30)
5AP A	Approx. 90	–	0.60 – 0.68 (0.024 – 0.027)	1.5 – 1.7 (0.059 – 0.067)	Approx. 7.4 (0.30)
5AP B	Approx. 90	3.5 – 6.5	0.72 – 0.81 (0.028 – 0.032)	1.5 – 1.7 (0.059 – 0.067)	Approx. 7.4 (0.30)
5AR A	Approx. 90	–	0.72 – 0.81 (0.028 – 0.032)	1.5 – 1.7 (0.059 – 0.067)	Approx. 7.4 (0.30)
5AR B	Approx. 90	3.5 – 6.5	0.81 – 0.90 (0.032 – 0.035)	1.5 – 1.7 (0.059 – 0.067)	Approx. 7.4 (0.30)
5AZ A	Approx. 90	–	1.43 – 1.54 (0.056 – 0.061)	1.5 – 1.7 (0.059 – 0.067)	Approx. 7.4 (0.30)
5AZ B	Approx. 90	–	1.54 – 1.66 (0.061 – 0.065)	1.5 – 1.7 (0.059 – 0.067)	Approx. 7.4 (0.30)
5CK A	Approx. 90	–	1.43 – 1.54 (0.056 – 0.061)	1.5 – 1.7 (0.059 – 0.067)	Approx. 7.4 (0.30)
5CK B	Approx. 90	–	1.43 – 1.54 (0.056 – 0.061)	1.5 – 1.7 (0.059 – 0.067)	Approx. 7.4 (0.30)
5EC A	Approx. 90	–	0.64 – 0.72 (0.025 – 0.028)	1.5 – 1.7 (0.059 – 0.067)	Approx. 7.4 (0.30)
5EC B	Approx. 90	–	0.64 – 0.72 (0.025 – 0.028)	1.5 – 1.7 (0.059 – 0.067)	Approx. 7.4 (0.30)
5ED A	Approx. 90	–	0.56 – 0.64 (0.022 – 0.025)	1.5 – 1.7 (0.059 – 0.067)	Approx. 7.4 (0.30)
5ED B	Approx. 90	–	0.56 – 0.64 (0.022 – 0.025)	1.5 – 1.7 (0.059 – 0.067)	Approx. 7.4 (0.30)
5EE A	Approx. 90	–	0.81 – 0.90 (0.032 – 0.035)	1.5 – 1.7 (0.059 – 0.067)	Approx. 7.4 (0.30)
5EE B	Approx. 90	–	0.81 – 0.90 (0.032 – 0.035)	1.5 – 1.7 (0.059 – 0.067)	Approx. 7.4 (0.30)

CONVENTIONAL CARB – Specifications

13A-1-19

Carburetor identi- fication No.	Slow-cut solenoid valve resistance [at 20°C (68°F)] Ω	Throttle position sensor resistance kΩ	Fast idle opening mm (in.)	Float level adjustment	
				Needle valve to float lever clearance mm (in.)	Float to air horn clearance mm (in.)
5EI A	Approx. 90	–	0.56 – 0.64 (0.022 – 0.025)	1.5 – 1.7 (0.059 – 0.067)	Approx. 7.4 (0.30)
5EI B	Approx. 90	–	0.56 – 0.64 (0.022 – 0.025)	1.5 – 1.7 (0.059 – 0.067)	Approx. 7.4 (0.30)
5EN A	Approx. 90	–	0.72 – 0.81 (0.028 – 0.032)	1.5 – 1.7 (0.059 – 0.067)	Approx. 7.4 (0.30)
5EO A	Approx. 90	–	0.56 – 0.64 (0.022 – 0.025)	1.5 – 1.7 (0.059 – 0.067)	Approx. 7.4 (0.30)
5EP A	Approx. 90	–	0.60 – 0.68 (0.024 – 0.027)	1.5 – 1.7 (0.059 – 0.067)	Approx. 7.4 (0.30)
5EQ A	Approx. 90	3.5 – 6.5	1.10 – 1.20 (0.043 – 0.047)	1.5 – 1.7 (0.059 – 0.067)	Approx. 7.4 (0.30)
5EU A	Approx. 90	–	0.56 – 0.64 (0.022 – 0.025)	1.5 – 1.7 (0.059 – 0.067)	Approx. 7.4 (0.30)
5EU B	Approx. 90	–	0.56 – 0.64 (0.022 – 0.025)	1.5 – 1.7 (0.059 – 0.067)	Approx. 7.4 (0.30)
5EV A	Approx. 90	–	0.60 – 0.72 (0.024 – 0.028)	1.5 – 1.7 (0.059 – 0.067)	Approx. 7.4 (0.30)
5EV B	Approx. 90	–	0.64 – 0.72 (0.025 – 0.028)	1.5 – 1.7 (0.059 – 0.067)	Approx. 7.4 (0.30)
5WK A	Approx. 90	–	0.81 – 0.90 (0.032 – 0.035)	1.5 – 1.7 (0.059 – 0.067)	Approx. 7.4 (0.30)
5WO A	Approx. 90	–	0.56 – 0.64 (0.022 – 0.025)	1.5 – 1.7 (0.059 – 0.067)	Approx. 7.4 (0.30)
5WP A	Approx. 90	–	0.60 – 0.68 (0.024 – 0.027)	1.5 – 1.7 (0.059 – 0.067)	Approx. 7.4 (0.30)
5WP B	Approx. 90	3.5 – 6.5	0.72 – 0.81 (0.028 – 0.032)	1.5 – 1.7 (0.059 – 0.067)	Approx. 7.4 (0.30)
5WU A	Approx. 90	–	0.56 – 0.64 (0.022 – 0.025)	1.5 – 1.7 (0.059 – 0.067)	Approx. 7.4 (0.30)
5WU B	Approx. 90	–	0.64 – 0.72 (0.025 – 0.028)	1.5 – 1.7 (0.059 – 0.067)	Approx. 7.4 (0.30)
5XC C	Approx. 90	–	1.31 – 1.43 (0.052 – 0.056)	1.5 – 1.7 (0.059 – 0.067)	Approx. 7.4 (0.30)
5XC D	Approx. 90	–	1.43 – 1.54 (0.056 – 0.061)	1.5 – 1.7 (0.059 – 0.067)	Approx. 7.4 (0.30)
5XD C	Approx. 90	–	1.20 – 1.31 (0.047 – 0.052)	1.5 – 1.7 (0.059 – 0.067)	Approx. 7.4 (0.30)
5XJ A	Approx. 90	–	1.20 – 1.31 (0.047 – 0.052)	1.5 – 1.7 (0.059 – 0.067)	Approx. 7.4 (0.30)
5XJ B	Approx. 90	–	1.20 – 1.31 (0.047 – 0.052)	1.5 – 1.7 (0.059 – 0.067)	Approx. 7.4 (0.30)

Carburetor identification No.	Slow-cut solenoid valve resistance [at 20°C (68°F)] Ω	Throttle position sensor resistance kΩ	Fast idle opening mm (in.)	Float level adjustment	
				Needle valve to float lever clearance mm (in.)	Float to air horn clearance mm (in.)
5XK A	Approx. 90	–	1.43 – 1.54 (0.056 – 0.061)	1.5 – 1.7 (0.059 – 0.067)	Approx. 7.4 (0.30)
5XK C	Approx. 90	–	1.43 – 1.54 (0.056 – 0.061)	1.5 – 1.7 (0.059 – 0.067)	Approx. 7.4 (0.30)
5XO A	Approx. 90	–	1.20 – 1.31 (0.047 – 0.052)	1.5 – 1.7 (0.059 – 0.067)	Approx. 7.4 (0.30)
5XO B	Approx. 90	3.5 – 6.5	0.56 – 0.64 (0.022 – 0.025)	1.5 – 1.7 (0.059 – 0.067)	Approx. 7.4 (0.30)
5XP A	Approx. 90	–	1.31 – 1.43 (0.052 – 0.056)	1.5 – 1.7 (0.059 – 0.067)	Approx. 7.4 (0.30)
5XP B	Approx. 90	3.5 – 6.5	1.43 – 1.54 (0.056 – 0.061)	1.5 – 1.7 (0.059 – 0.067)	Approx. 7.4 (0.30)
5XR A	Approx. 90	–	1.31 – 1.43 (0.052 – 0.056)	1.5 – 1.7 (0.059 – 0.067)	Approx. 7.4 (0.30)
5XR B	Approx. 90	3.5 – 6.5	1.43 – 1.54 (0.056 – 0.061)	1.5 – 1.7 (0.059 – 0.067)	Approx. 7.4 (0.30)
5XU A	Approx. 90	–	1.10 – 1.20 (0.043 – 0.047)	1.5 – 1.7 (0.059 – 0.067)	Approx. 7.4 (0.30)
5XU B	Approx. 90	–	1.10 – 1.20 (0.043 – 0.047)	1.5 – 1.7 (0.059 – 0.067)	Approx. 7.4 (0.30)
7BH A	Approx. 90	–	1.20 – 1.31 (0.047 – 0.052)	1.5 – 1.7 (0.059 – 0.067)	Approx. 7.4 (0.30)
7BJ A	Approx. 90	–	1.43 – 1.54 (0.056 – 0.061)	1.5 – 1.7 (0.059 – 0.067)	Approx. 7.4 (0.30)
7BK A	Approx. 90	–	1.31 – 1.43 (0.052 – 0.056)	1.5 – 1.7 (0.059 – 0.067)	Approx. 8.0 (0.31)
7BL A	Approx. 90	–	1.20 – 1.31 (0.047 – 0.052)	1.5 – 1.7 (0.059 – 0.067)	Approx. 8.0 (0.31)
7EG A	Approx. 90	–	0.90 – 1.00 (0.035 – 0.039)	1.5 – 1.7 (0.059 – 0.067)	Approx. 7.4 (0.30)
7DE A	Approx. 90	–	0.64 – 0.72 (0.025 – 0.028)	1.5 – 1.7 (0.059 – 0.067)	Approx. 7.4 (0.30)

Intentionally blank

SERVICE SPECIFICATIONS
CARBURETOR – MIKUNI TYPE

Carburetor identification No.	Slow-cut solenoid valve resistance [at 20°C (68°F)] Ω	Throttle position sensor resistance kΩ	Fast idle opening mm (in.)	Float level adjustment	
				Needle valve to float leve clearance mm (in.)	Float to air horn clearance mm (in.)
30-32DIDTA-342	48 – 60	–	0.51 – 0.58 (0.020 – 0.023)	–	–
30-32DIDTA-343	48 – 60	–	0.58 – 0.66 (0.023 – 0.026)	–	–
32-35DIDSA-20	48 – 60	–	1.15 – 1.62 (0.045 – 0.064)	–	–
32-35DIDSA-21	48 – 60	–	1.15 – 1.62 (0.045 – 0.064)	–	–
32-35DIDSA-22	48 – 60	–	1.15 – 1.62 (0.045 – 0.064)	–	–
32-35DIDSA-23	48 – 60	–	1.15 – 1.62 (0.045 – 0.064)	–	–
32-35DIDSA-24	48 – 60	–	1.15 – 1.62 (0.045 – 0.064)	–	–
32-35DIDSA-25	48 – 60	–	1.15 – 1.62 (0.045 – 0.064)	–	–
32-35DIDSA-26	48 – 60	–	1.15 – 1.62 (0.045 – 0.064)	–	–
32-35DIDSA-27	48 – 60	–	1.15 – 1.62 (0.045 – 0.064)	–	–
32-35DIDSA-28	48 – 60	–	1.15 – 1.62 (0.045 – 0.064)	–	–
32-35DIDSA-31	48 – 60	–	1.10 – 1.56 (0.043 – 0.061)	–	–
32-35DIDSA-32	48 – 60	–	1.10 – 1.56 (0.043 – 0.061)	–	–
32-35DIDSA-34	48 – 60	–	1.10 – 1.56 (0.043 – 0.061)	–	–
32-35DIDSA-39	48 – 60	–	1.10 – 1.56 (0.043 – 0.061)	–	–
32-35DIDSA-42	48 – 60	–	1.10 – 1.56 (0.043 – 0.061)	–	–
32-35DIDSA-45	48 – 60	–	1.27 – 1.75 (0.050 – 0.069)	–	–
32-35DIDTA-378	48 – 60	–	0.76 – 0.85 (0.030 – 0.033)	–	–
32-35DIDTA-380	48 – 60	–	0.76 – 0.85 (0.030 – 0.033)	–	–
32-35DIDTA-382	48 – 60	–	0.59 – 0.67 (0.023 – 0.026)	–	–

CONVENTIONAL CARB – Specifications

13A-1-21

Carburetor identification No.	Slow-cut solenoid valve resistance [at 20°C (68°F)] Ω	Throttle position sensor resistance kΩ	Fast idle opening mm (in.)	Float level adjustment	
				Needle valve to float level clearance mm (in.)	Float to air horn clearance mm (in.)
32-35DIDTA-383	48 – 60	–	0.67 – 0.76 (0.026 – 0.030)	–	–
32-35DIDTA-386	48 – 60	–	0.67 – 0.76 (0.026 – 0.030)	–	–
32-35DIDTA-387	48 – 60	–	0.76 – 0.85 (0.030 – 0.033)	–	–
32-35DIDTA-388	48 – 60	–	0.55 – 0.63 (0.022 – 0.025)	–	–
32-35DIDTA-389	48 – 60	–	0.76 – 0.85 (0.030 – 0.033)	–	–
32-35DIDTA-391	48 – 60	–	0.67 – 0.76 (0.026 – 0.030)	–	–
32-35DIDTA-392	48 – 60	–	0.76 – 0.85 (0.030 – 0.033)	–	–
32-35DIDTA-393	48 – 60	–	0.76 – 0.85 (0.030 – 0.033)	–	–
32-35DIDTA-394	48 – 60	–	0.67 – 0.76 (0.026 – 0.030)	–	–
32-35DIDTA-395	48 – 60	–	0.76 – 0.85 (0.030 – 0.033)	–	–
32-35DIDTA-396	48 – 60	–	0.76 – 0.85 (0.030 – 0.033)	–	–
32-35DIDTA-397	48 – 60	–	0.76 – 0.85 (0.030 – 0.033)	–	–
32-35DIDTA-398	48 – 60	–	0.76 – 0.85 (0.030 – 0.033)	–	–
32-35DIDTA-460	48 – 60	–	0.51 – 0.59 (0.020 – 0.023)	–	–
32-35DIDTA-461	48 – 60	3.5 – 6.5	0.59 – 0.67 (0.023 – 0.026)	–	–
32-35DIDTA-462	48 – 60	–	0.51 – 0.59 (0.020 – 0.023)	–	–
32-35DIDTA-463	48 – 60	3.5 – 6.5	0.59 – 0.67 (0.023 – 0.026)	–	–
32-35DIDTA-464	48 – 60	–	0.51 – 0.59 (0.020 – 0.023)	–	–
32-35DIDTA-465	48 – 60	3.5 – 6.5	0.59 – 0.67 (0.023 – 0.026)	–	–
32-35DIDTA-466	48 – 60	–	0.59 – 0.67 (0.021 – 0.026)	–	–
32-35DIDTA-467	48 – 60	3.5 – 6.5	0.67 – 0.76 (0.026 – 0.030)	–	–

Carburetor identification No.	Slow-cut solenoid valve resistance [at 20°C (68°F)] Ω	Throttle position sensor resistance kΩ	Fast idle opening mm (in.)	Float level adjustment	
				Needle valve to float level clearance mm (in.)	Float to air horn clearance mm (in.)
32-35DIDTA-468	48 - 60	-	0.59 - 0.67 (0.021 - 0.026)	-	-
32-35DIDTA-469	48 - 60	3.5 - 6.5	0.67 - 0.76 (0.026 - 0.030)	-	-
32-35DIDTA-490	48 - 60	-	0.59 - 0.67 (0.021 - 0.026)	-	-
32-35DIDTA-491	48 - 60	3.5 - 6.5	0.71 - 0.80 (0.028 - 0.031)	-	-
32-35DIDTA-492	48 - 60	-	0.59 - 0.67 (0.021 - 0.026)	-	-
32-35DIDTA-493	48 - 60	3.5 - 6.5	0.71 - 0.80 (0.028 - 0.031)	-	-
32-35DIDTA-496	48 - 60	-	0.59 - 0.67 (0.021 - 0.026)	-	-
32-35DIDTA-497	48 - 60	3.5 - 6.5	0.71 - 0.80 (0.028 - 0.031)	-	-
32-35DIDTA-498	48 - 60	-	0.67 - 0.76 (0.026 - 0.030)	-	-
32-35DIDTA-499	48 - 60	3.5 - 6.5	0.80 - 0.90 (0.031 - 0.035)	-	-
32-35DIDTA-510	48 - 60	-	0.59 - 0.67 (0.023 - 0.026)	-	-
32-35DIDTA-511	48 - 60	3.5 - 6.5	0.67 - 0.76 (0.026 - 0.030)	-	-
32-35DIDTA-514	48 - 60	-	0.59 - 0.67 (0.023 - 0.026)	-	-
32-35DIDTA-515	48 - 60	3.5 - 6.5	0.67 - 0.76 (0.026 - 0.030)	-	-
32-35DIDTA-520	48 - 60	-	0.67 - 0.76 (0.026 - 0.030)	-	-
32-35DIDTA-521	48 - 60	-	0.80 - 0.90 (0.031 - 0.035)	-	-
32-35DIDTA-522	48 - 60	-	0.67 - 0.76 (0.026 - 0.030)	-	-
32-35DIDTA-523	48 - 60	-	0.80 - 0.90 (0.031 - 0.035)	-	-
32-35DIDTA-527	48 - 60	-	0.67 - 0.76 (0.026 - 0.030)	-	-
32-35DIDTA-529	48 - 60	-	0.67 - 0.76 (0.026 - 0.030)	-	-
32-35DIDTA-530	48 - 60	-	0.59 - 0.67 (0.023 - 0.026)	-	-
32-35DIDTA-531	48 - 60	-	0.67 - 0.76 (0.026 - 0.030)	-	-

Carburetor identification No.	Slow-cut solenoid valve resistance [at 20°C (68°F)] Ω	Throttle position sensor resistance kΩ	Fast idle opening mm (in.)	Float level adjustment	
				Needle valve to float level clearance mm (in.)	Float to air horn clearance mm (in.)
32-35DIDTA-535	48 – 60	–	0.80 – 0.90 (0.031 – 0.035)	–	–
32-35DIDTA-537	48 – 60	–	0.67 – 0.76 (0.026 – 0.030)	–	–
32-35DIDTA-538	48 – 60	–	0.80 – 0.90 (0.031 – 0.035)	–	–
32-35DIDTA-542	48 – 60	–	0.67 – 0.76 (0.026 – 0.030)	–	–
32-35DIDTA-548	48 – 60	–	0.85 – 0.95 (0.033 – 0.037)	–	–
32-35DIDTA-550	48 – 60	3.5 – 6.5	0.67 – 0.76 (0.026 – 0.030)	–	–
32-35DIDTA-551	48 – 60	–	0.67 – 0.76 (0.026 – 0.030)	–	–
32-35DIDTA-552	48 – 60	–	0.67 – 0.76 (0.026 – 0.030)	–	–
32-35DIDTA-555	48 – 60	–	0.59 – 0.67 (0.023 – 0.026)	–	–
32-35DIDTA-556	48 – 60	3.5 – 6.5	0.67 – 0.76 (0.026 – 0.030)	–	–
32-35DIDTA-557	48 – 60	–	0.59 – 0.67 (0.023 – 0.026)	–	–
32-35DIDTA-558	48 – 60	3.5 – 6.5	0.67 – 0.76 (0.026 – 0.030)	–	–
32-35DIDTA-562	48 – 60	–	0.67 – 0.76 (0.026 – 0.030)	–	–
32-35DIDTA-563	48 – 60	3.5 – 6.5	0.80 – 0.90 (0.031 – 0.035)	–	–
32-35DIDTA-564	48 – 60	–	0.67 – 0.76 (0.026 – 0.030)	–	–
32-35DIDTA-565	48 – 60	3.5 – 6.5	0.80 – 0.90 (0.031 – 0.035)	–	–

COLD MIXTURE HEATER

	Standard value
Resistance [at 20°C (68°F)]	Approx. 1 Ω

TORQUE SPECIFICATIONS

	Torque		
	Nm	kgm	ft.lbs.
Carburetor (AISAN-type) mounting bolt	12	1.2	9
Carburetor (MIKUNI-type) mounting nut	18	1.8	13
Stud	12	1.2	9

NOTES

2. SPECIAL TOOLS

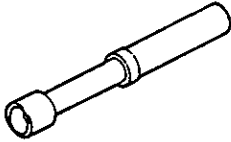
Tool	Number	Name	Use
	MD998299	MAS driver	Adjustment of idle mixture and removal and installation of MAS

NOTES

3. FUEL PUMP

REMOVAL AND INSTALLATION – 4G1

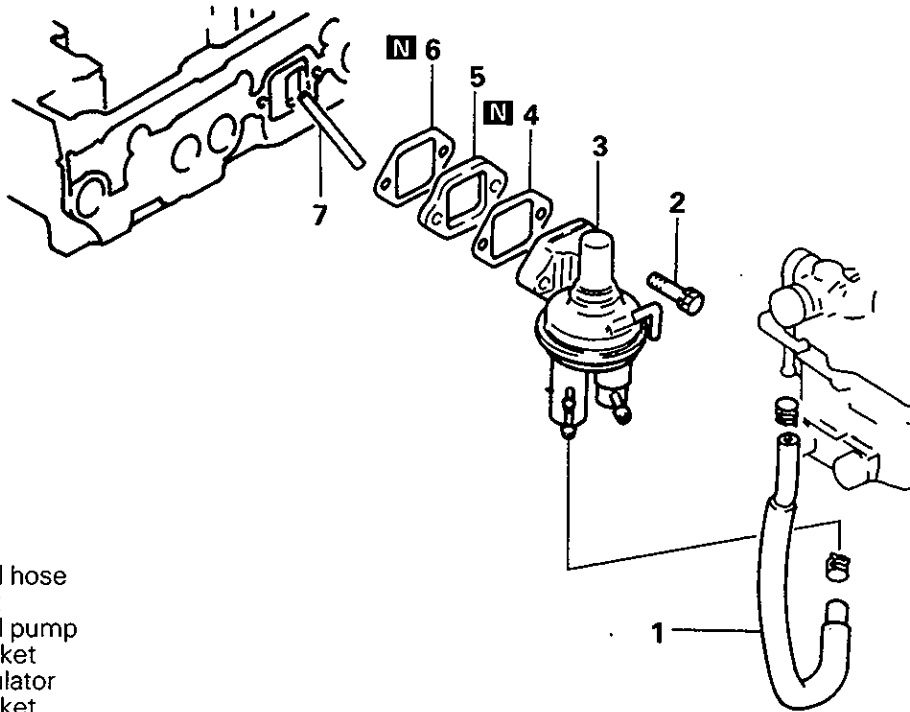

Removal steps

- 1. Fuel hose
- 2. Bolt
- ◁A▷ ▷A◁ 3. Fuel pump
- 4. Gasket
- 5. Insulator
- 6. Gasket
- 7. Push rod

1FU0008

REMOVAL AND INSTALLATION – 4G3

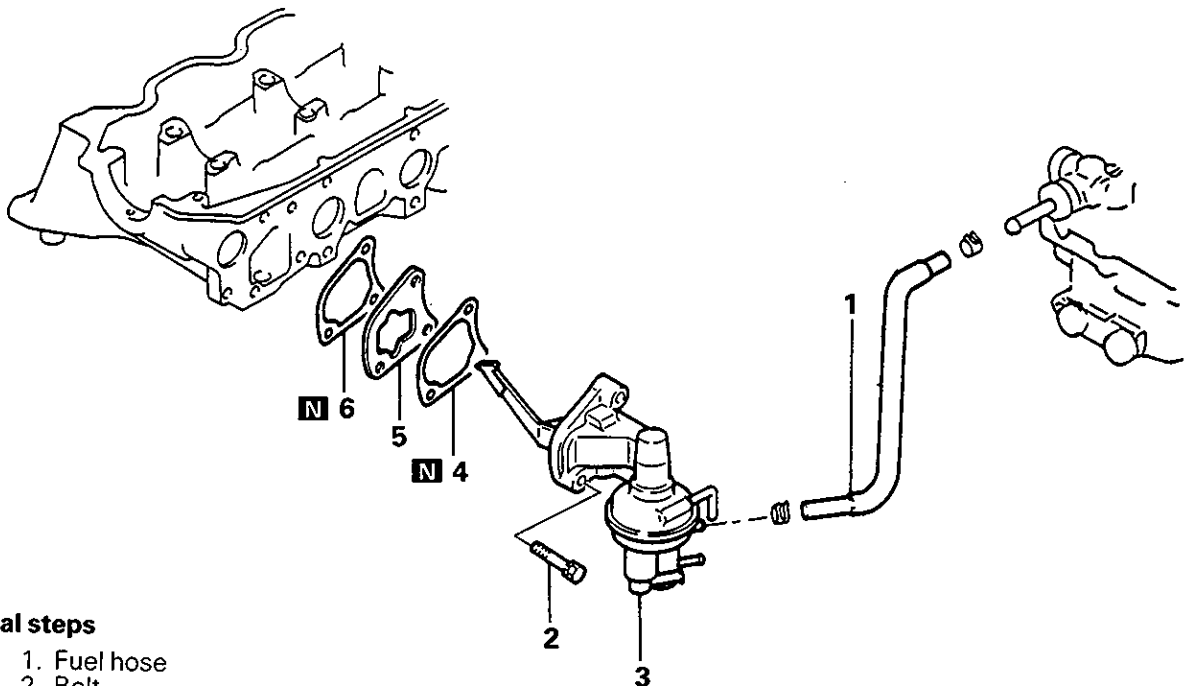

Removal steps

- 1. Fuel hose
- 2. Bolt
- ◁B▷ ▷B◁ 3. Fuel pump
- 4. Gasket
- 5. Insulator
- 6. Gasket

3FU204

REMOVAL AND INSTALLATION – 4G5

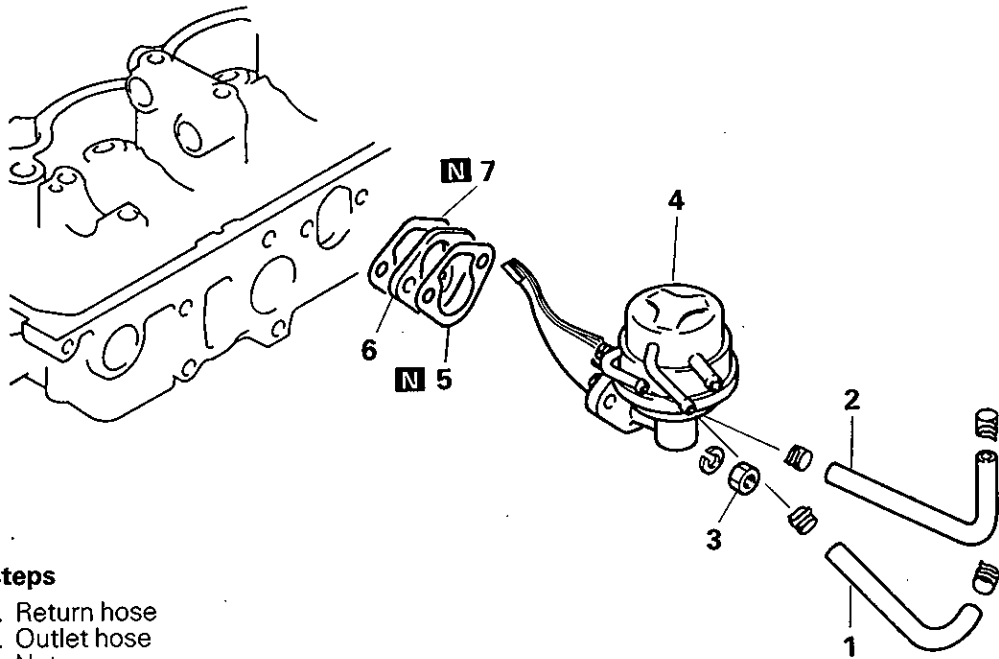

Removal steps

1. Return hose
2. Outlet hose
3. Nut
4. Fuel pump
5. Gasket
6. Insulator
7. Gasket

◊C◊ ◊A◊

5FU005

REMOVAL AND INSTALLATION – 4G9

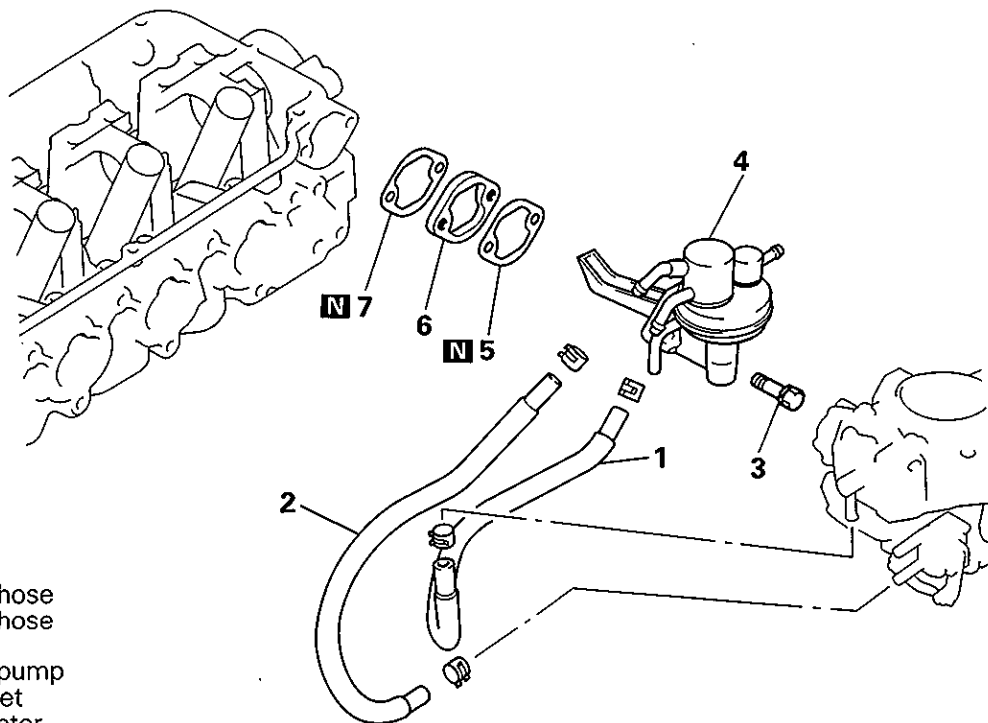

Removal steps

1. Fuel hose
2. Fuel hose
3. Bolt
4. Fuel pump
5. Gasket
6. Insulator
7. Gasket

◊B◊ ◊B◊

9FU0087

REMOVAL AND INSTALLATION – 4G6

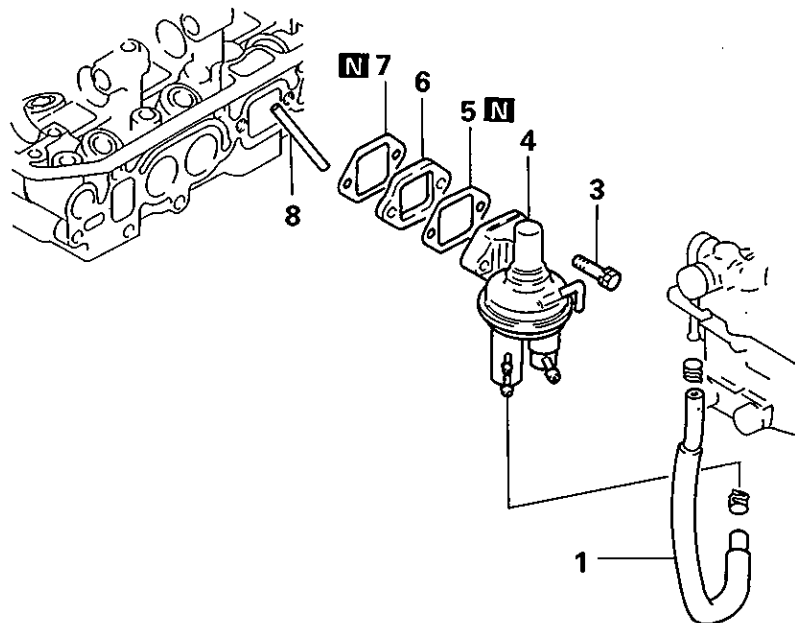

6FU356

Type C carburetor only

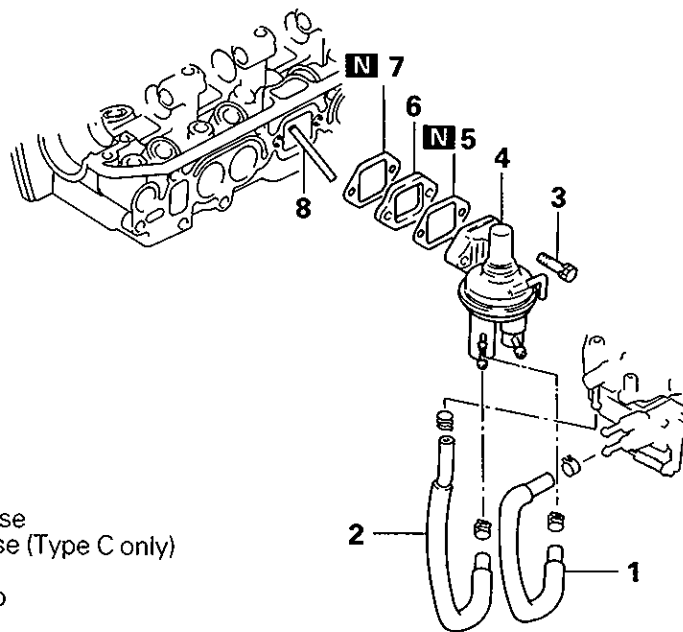

Removal steps

1. Return hose
2. Outlet hose (Type C only)
3. Nut
4. Fuel pump
5. Gasket
6. Insulator
7. Gasket
8. Push rod



6FU366

SERVICE POINTS OF REMOVAL**◁A▷ REMOVAL OF FUEL PUMP – 4G1, 4G6**

- (1) Placing the piston in No. 1 cylinder at TDC on the compression stroke makes the fuel pump stroke lift the smallest, allowing easy removal of the pump.

◁B▷ REMOVAL OF FUEL PUMP – 4G3

- (1) Placing the piston in No. 2 cylinder at TDC on the compression stroke makes the fuel pump stroke lift the smallest, allowing easy removal of the pump.

◁C▷ REMOVAL OF FUEL PUMP – 4G5

- (1) Placing the piston in No. 1 cylinder at TDC on the compression stroke makes the fuel pump stroke lift the smallest, allowing easy removal of the pump.

Caution

- Loosening the cylinder head mounting bolt and sliding the washer a little facilitates pump removal.

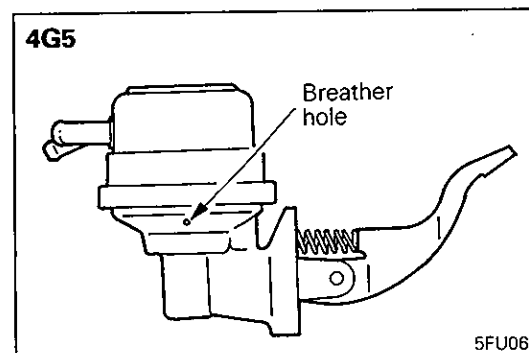
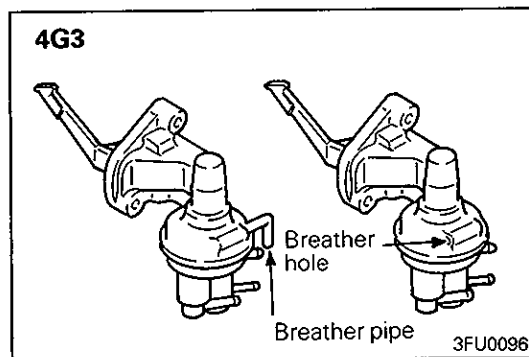
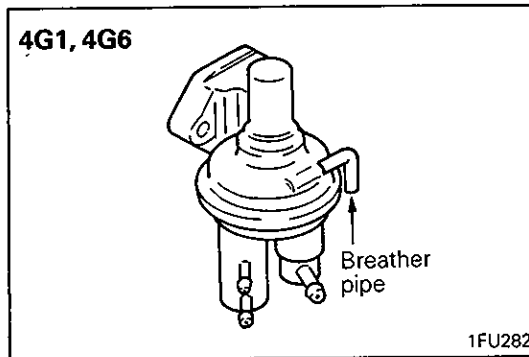
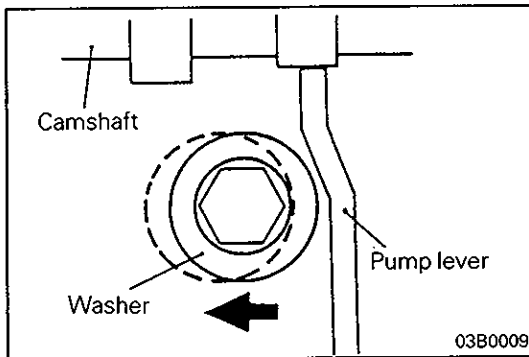
**INSPECTION****FUEL PUMP**

Check the following and replace if faulty. The fuel pump cannot be disassembled. Therefore, replace as an assembly if necessary.

- (1) Check the breather pipe and hole for oil or fuel leaks.
- (2) Check parts for damage and cracks.
- (3) Check the rocker arm for wear (4G3 and 4G5 only).

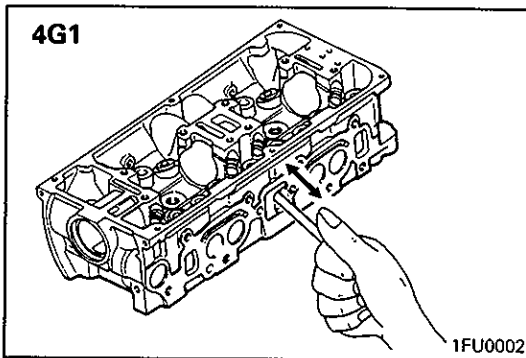
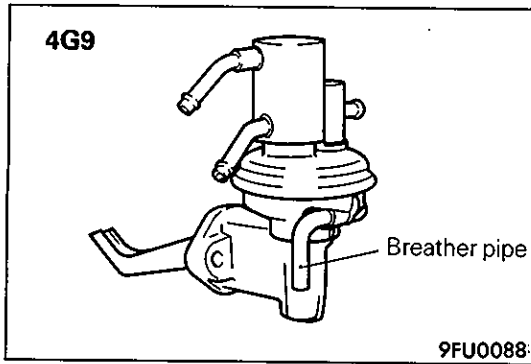

PUSH ROD – 4G1, 4G6

- (1) Check that the push rod inserted in the cylinder head hole slides smoothly without excessive play.
- (2) Check the camshaft eccentric cam for wear.

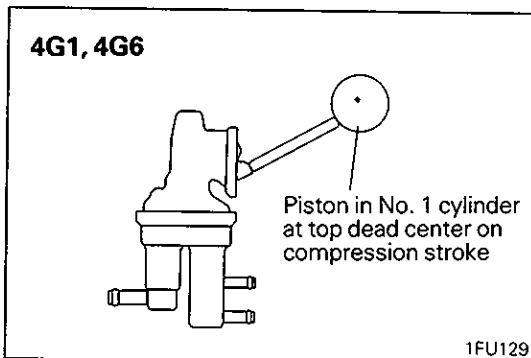
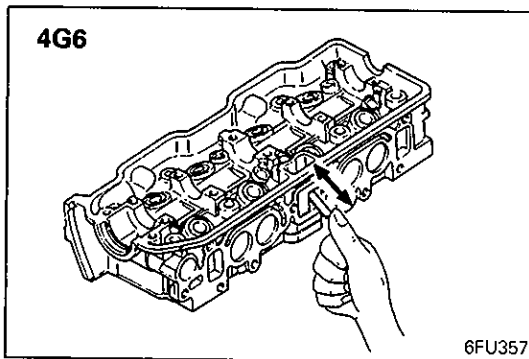

SERVICE POINTS OF INSTALLATION

INSTALLATION OF FUEL PUMP – 4G1, 4G5, 4G6

- (1) Bring the piston in No. 1 cylinder to TDC on the compression stroke. This provides the smallest lift of eccentric cam, allowing easy installation of the fuel pump.

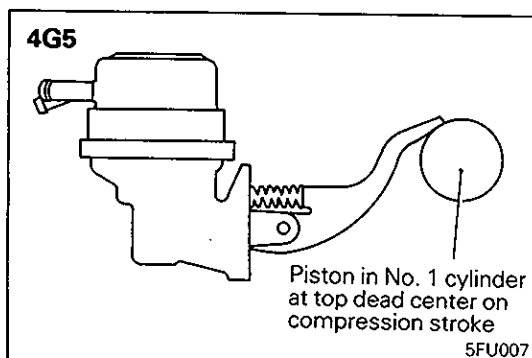

◆B◆ INSTALLATION OF FUEL PUMP – 4G3, 4G9

- (1) Bring the piston in No. 2 cylinder to TDC on the compression stroke. This provides the smallest lift of eccentric cam, allowing easy installation of the fuel pump.

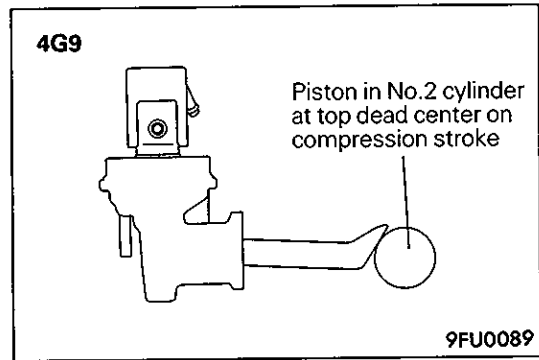
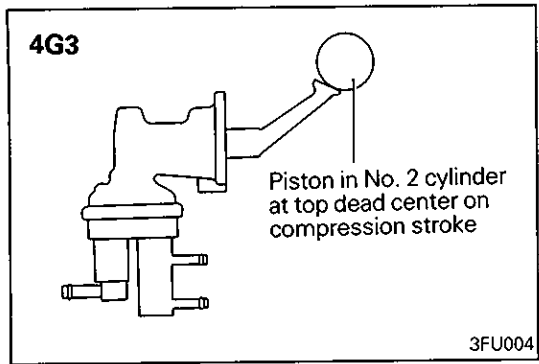

4. CARBURETOR ASSEMBLY

REMOVAL AND INSTALLATION – Types "A" and "B"

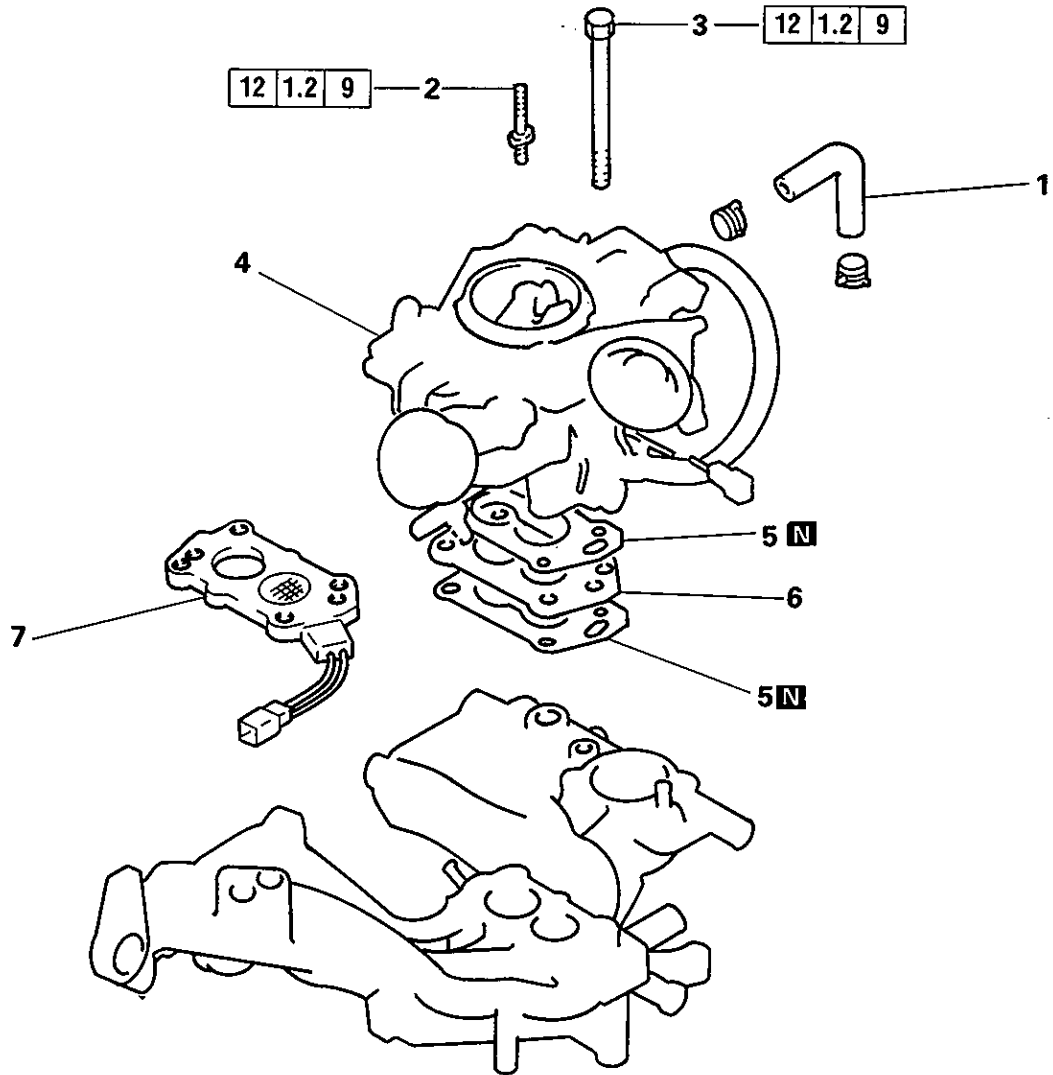

Removal steps

- 1. Water hose
- 2. Stud
- 3. Bolt with spring washer
- 4. Carburetor
- 5. Gasket – Fiber type
- 5N Gasket – Metal type
- 6. Insulator
- 7. Cold mixture heater

◆A◆
◆A◆

REMOVAL AND INSTALLATION – Types “C” and “D”

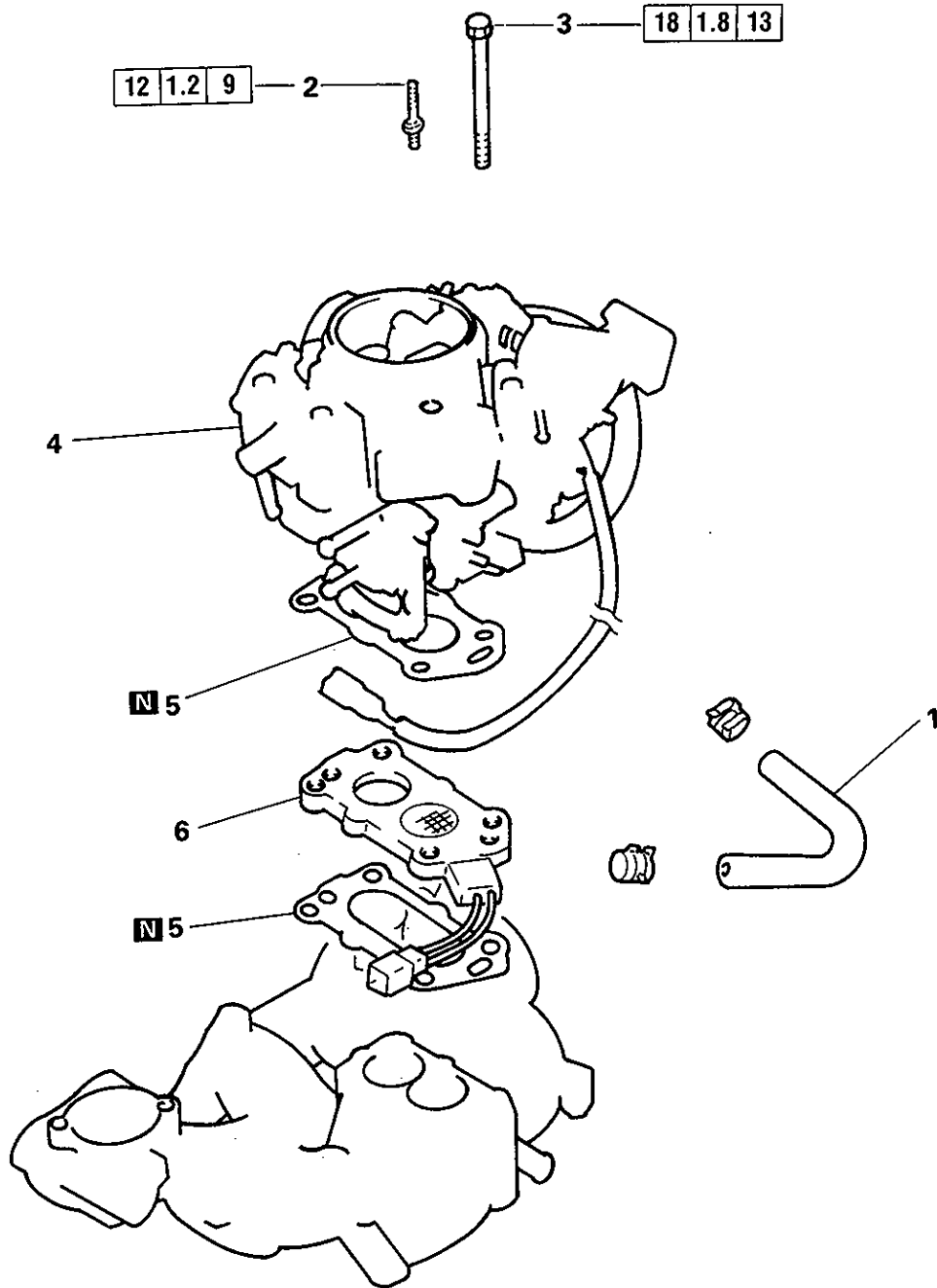

Removal steps

1. Water hose
2. Stud
3. Bolt with spring washer
4. Carburetor
5. Gasket – Fiber type
Gasket – Metal type
6. Cold mixture heater

⇨A⇨
◇A◇

SERVICE POINT OF REMOVAL

REMOVAL OF COLD MIXTURE HEATER

- (1) Do not drop the cold mixture heater from a height of more than 30 cm (11.81 in.). Never use the dropped cold mixture heater.

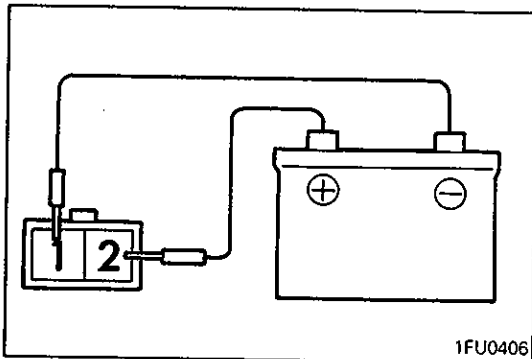
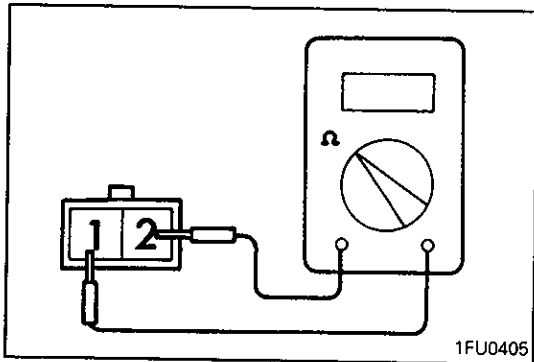

INSPECTION

COLD MIXTURE HEATER

- (1) Check continuity of the cold mixture heater.
Standard value: Conductive [with approx. 1 Ω resistance at 20°C (68°F)]

- (2) Apply battery voltage directly to the heater terminal and check that the heater becomes hot.

SERVICE POINTS OF INSTALLATION

INSTALLATION OF METAL GASKET

- (1) Using the threaded holes for mounting the carburetor on the intake manifold, stand two guide rods [threaded end dia.: 6.6 mm (0.26 in.), shank dia.: 8.0 mm (0.31 in.)]. Stand two guide rods diagonally as illustrated.
- (2) Set the carburetor gasket and the carburetor on the intake manifold along the guide rods.

NOTE

After setting, do not move the carburetor.

- (3) Insert the carburetor attaching bolts to the two vacant screw holes and tighten them finger-tight.
- (4) Remove the guide rods, insert the carburetor attaching bolts in their place and tighten finger-tight.
- (5) Tighten the four carburetor attaching bolts to specified torque.

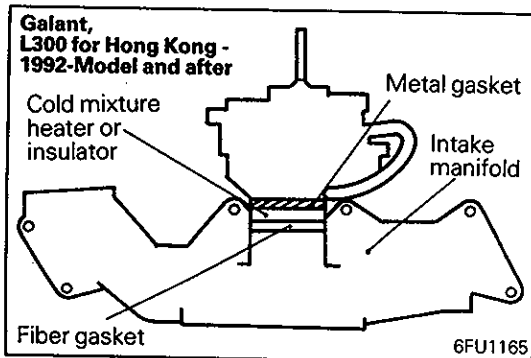
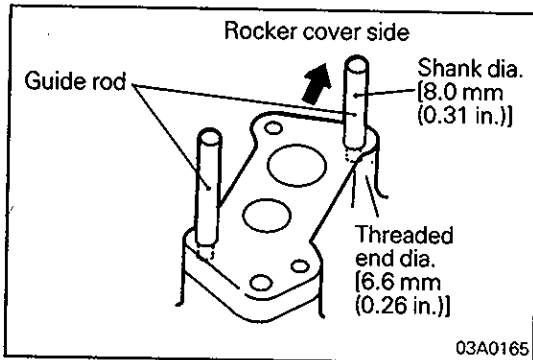

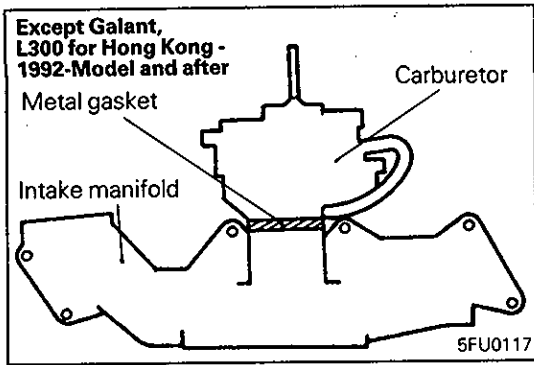

5. CARBURETOR – Types “A” and “B”

DISASSEMBLY AND REASSEMBLY – Type “A”

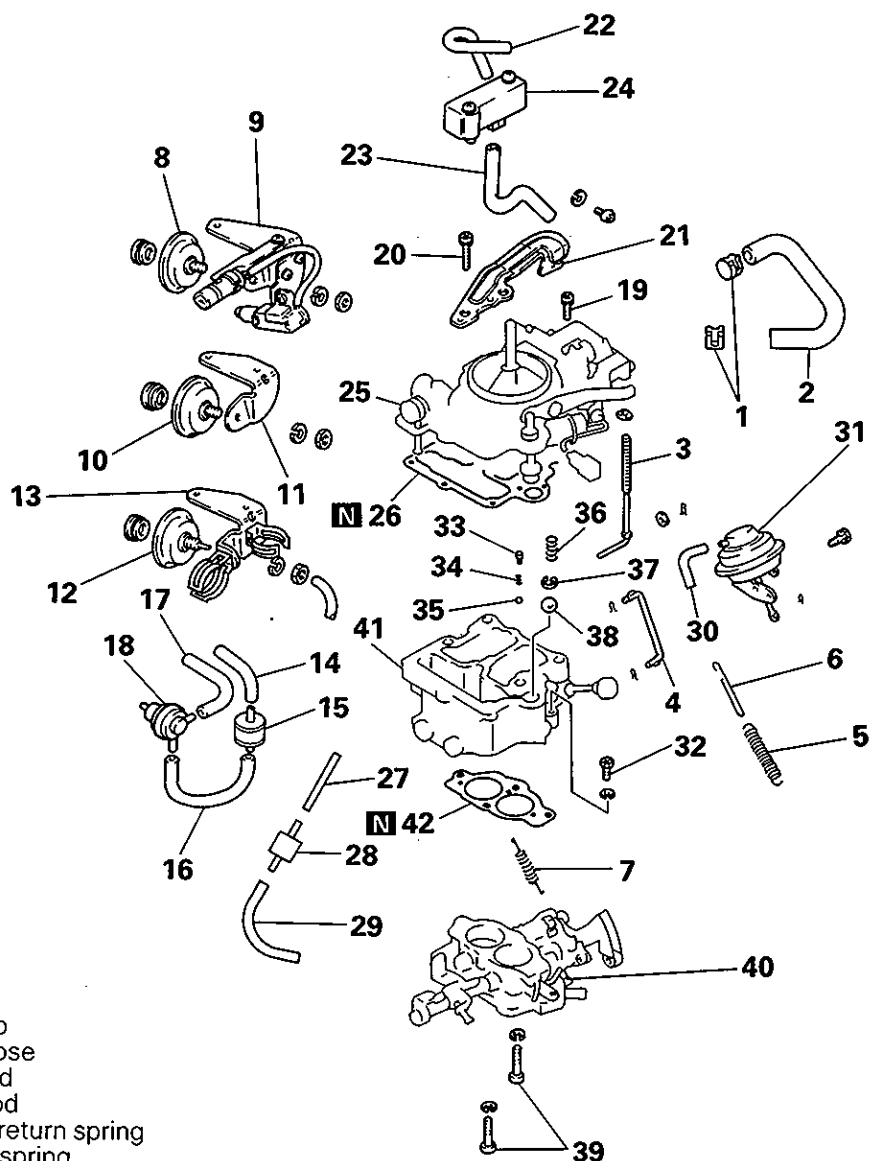

Disassembly steps

- | | |
|---|-----------------------------|
| 1. Hose clip | 26. Gasket |
| 2. Water hose | 27. Hose |
| 3. Pump rod | 28. Vacuum delay valve |
| 4. Choke rod | 29. Hose |
| 5. Throttle return spring | 30. Hose |
| 6. Damper spring | 31. Diaphragm chamber |
| 7. Cam follower return spring | 32. Screw |
| 8. Dash pot | ♠D♠ 33. Weight |
| 9. Bracket and throttle position sensor (TPS) | ♠D♠ 34. Spring |
| 10. Dash pot | ♠D♠ 35. Check ball (outlet) |
| 11. Bracket | 36. Pump dumper spring |
| 12. Dash pot (CV-type) | ♠D♠ 37. Retainer |
| 13. Bracket (CV-type) | ♠D♠ 38. Check ball (inlet) |
| 14. Hose | 39. Screw |
| 15. Delay valve | 40. Throttle body assembly |
| 16. Hose | 41. Main body assembly |
| 17. Hose | 42. Gasket |
| 18. Servo valve | |
| 19. Screw | |
| 20. Screw | |
| 21. Accelerator wire bracket | |
| 22. Hose | |
| 23. Hose | |
| 24. Idle compensator valve | |
| 25. Air horn assembly | |

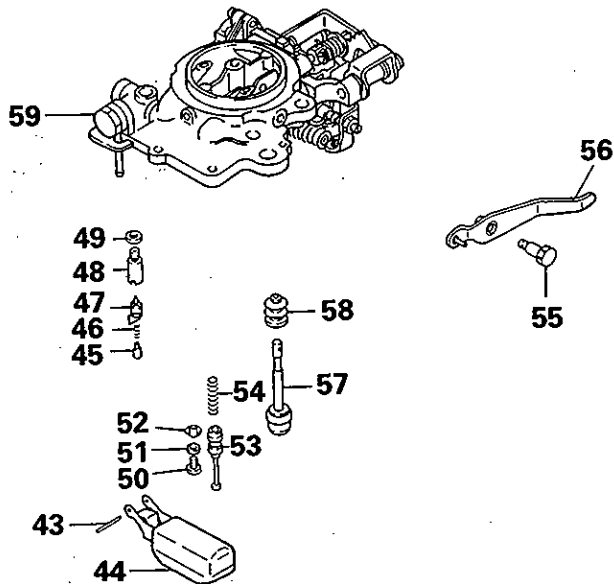

Disassembly steps

- ▶C▶ 43. Float Pin
- ▶C▶ 44. Float
- 45. Push pin
- 46. Spring
- 47. Needle valve
- 48. Needle valve seat
- 49. Gasket
- 50. Screw
- 51. Washer
- 52. Power piston stopper
- 53. Power piston
- 54. Power piston spring
- 55. Special screw
- 56. Pump lever
- ▶B▶ 57. Pump plunger
- 58. Boot
- 59. Air horn

1FU307

Disassembly steps

- ◊A◊ 60. Mixture adjusting screw (MAS)
- 61. Spring
- 62. Throttle lever (M/T)
- 63. Throttle lever (A/T)
- 64. Lever
- 65. Cam follower
- 66. Fast idle adjusting screw
- 67. Abutment lever
- 68. Dash pot lever "A"
- 69. Spring
- 70. Dash pot adjusting screw
- 71. Dash pot lever "B"
- 72. Spring
- 73. Throttle body

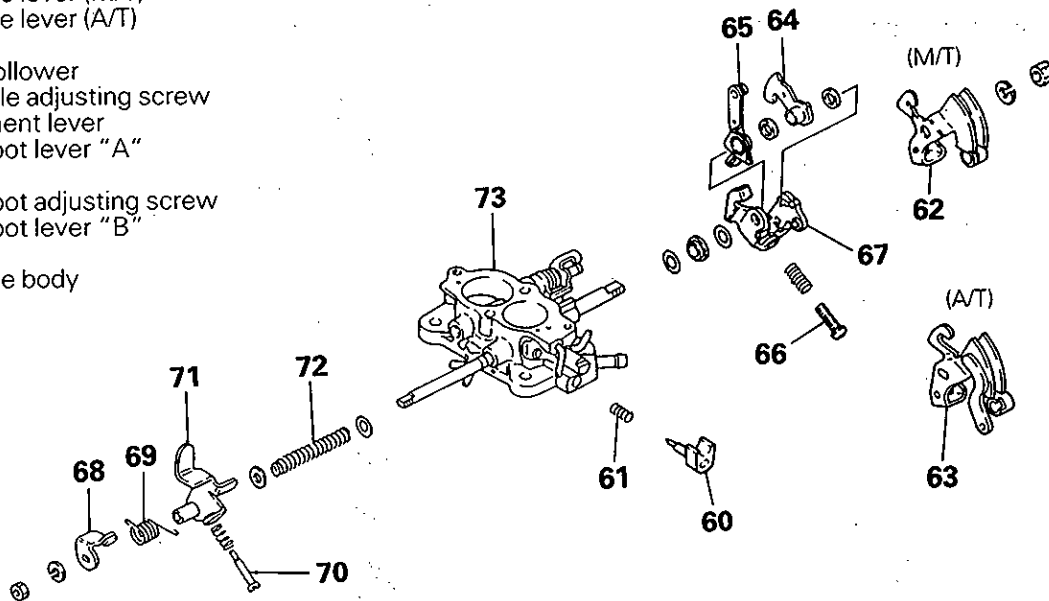

1FU0015

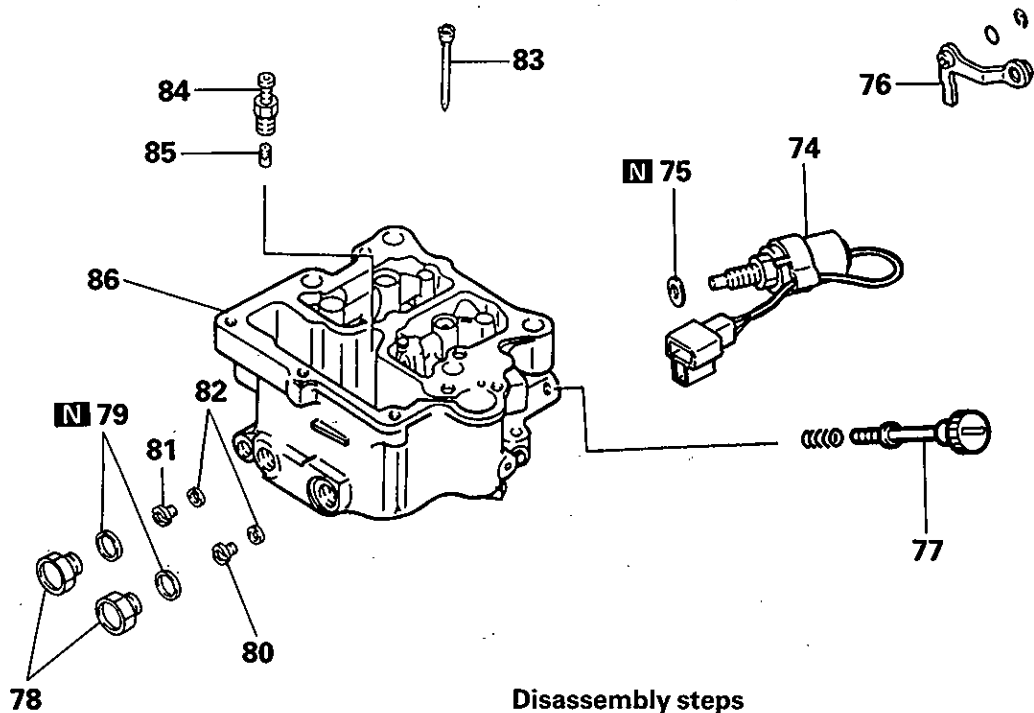

Disassembly steps

- 74. Fuel cut solenoid valve
- 75. Gasket
- 76. Lever
- 77. Speed adjusting screw (SAS)
- 78. Plug
- 79. Gasket
- ◊B◊ ◊A◊ 80. Primary main jet
- ◊B◊ ◊A◊ 81. Secondary main jet
- 82. Gasket
- ◊B◊ ◊A◊ 83. Slow jet
- ◊A◊ 84. Power valve
- ◊A◊ 85. Power jet
- 86. Main body

1FU309

DISASSEMBLY AND REASSEMBLY – Type “B”

Disassembly steps

1. Secondary spring
2. Return spring
3. Damper spring
4. Choke rod
5. Pump arm spring
6. Pump connecting link
7. Dash pot
8. Bracket and throttle position sensor (TPS)
9. Dash pot
10. Bracket
11. Dash pot (CV-type)
12. Bracket (CV-type)
13. Hose
14. Delay valve
15. Hose
16. Hose
17. Servo valve
18. Pump lever
19. Bracket
20. Hose
21. Hose
22. Idle compensator valve
23. Screw
- ◆C◆ 24. Float pin
- ◆C◆ 25. Float
26. Needle valve
27. Needle valve seat
28. Power piston
- ◆D◆ 29. Pump plunger
30. Air horn
31. Gasket
32. Pump damper spring
- ◆D◆ 33. Weight
- ◆D◆ 34. Spring
- ◆D◆ 35. Check ball (outlet)
- ◆D◆ 36. Retainer
- ◆D◆ 37. Check ball (inlet)
- ◇B◇ ◆A◆ 38. Slow jet
- ◆A◆ 39. Power valve
- ◆A◆ 40. Power jet
41. Fuel cut solenoid valve
42. Vacuum hose
43. Depression chamber
44. Plug
- ◇B◇ ◆A◆ 45. Primary main jet
- ◇B◇ ◆A◆ 46. Secondary main jet
47. Speed adjusting screw (SAS)
48. Screw
49. Screw
50. Main body
51. Gasket
52. Throttle lever
53. Lever
54. Fast idle lever
55. Fast idle adjusting screw
56. Lever
57. Mixture adjusting screw (MAS)
58. Throttle body

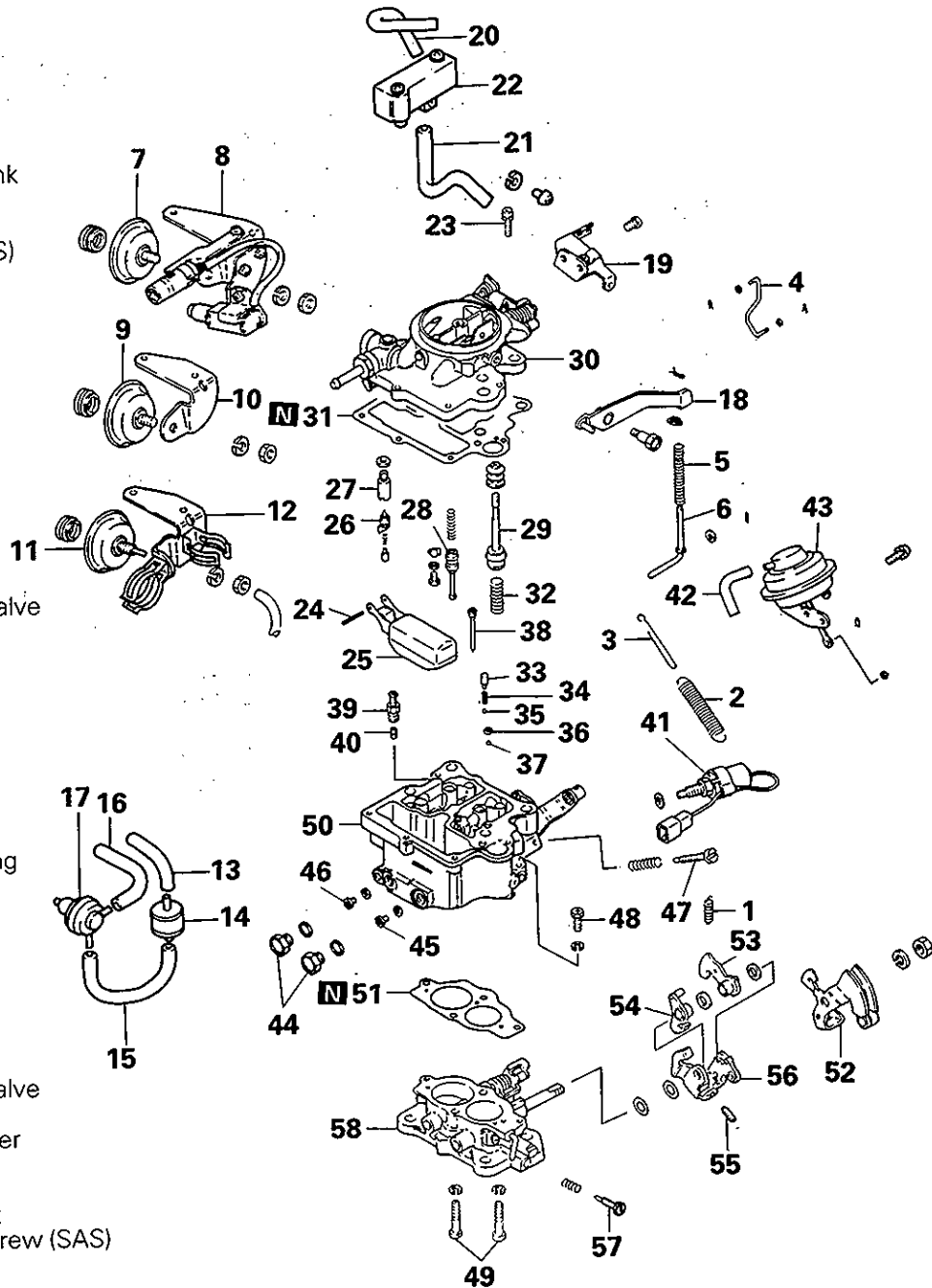

SERVICE POINTS OF DISASSEMBLY

The following parts must not be disassembled at the time of disassembly.

- (1) Choke valve, choke shaft and automatic choke unit
- (2) Inner venturi
- (3) Throttle valve and throttle shaft
- (4) Fuel inlet nipple

When loosening a cross recessed head screw, use a Phillips screwdriver which is an exact fit to the screw as it has been tightened securely.

When removing each jet, use a screwdriver which fits the slot exactly and work carefully so as not to damage the jet.

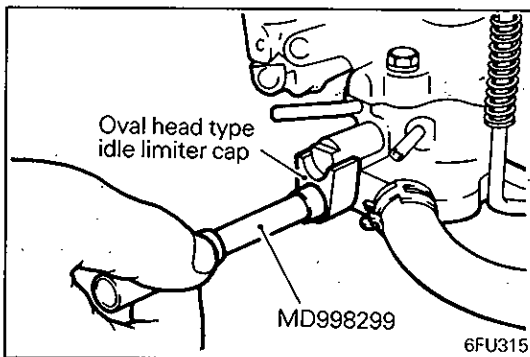

◁A▷ REMOVAL OF MIXTURE ADJUSTING SCREW (MAS)

- (1) Using the special tool (MAS Driver), remove the idle limiter cap and the MAS.

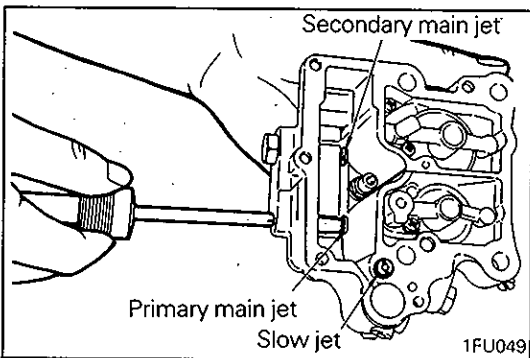

◁B▷ REMOVAL OF MAIN JET / SLOW JET

- (1) When removing the jets, first remove the plug and then insert a screwdriver through the plug hole to remove the main jet.

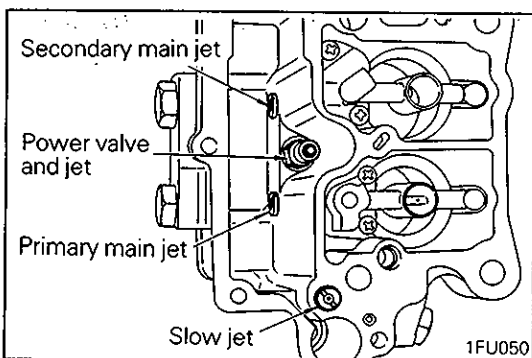

INSPECTION

GENERAL INSPECTION

Check the following and repair or replace parts if faulty.

- (1) Check fuel passages (jets) and air passages (jets or orifices) for clogging. If clogged, wash thoroughly with cleaning solvent or detergent and remove dirt by compressed air. Do not use wire or other metal pieces.
- (2) Check diaphragms, O-rings and springs for damage and cracks.

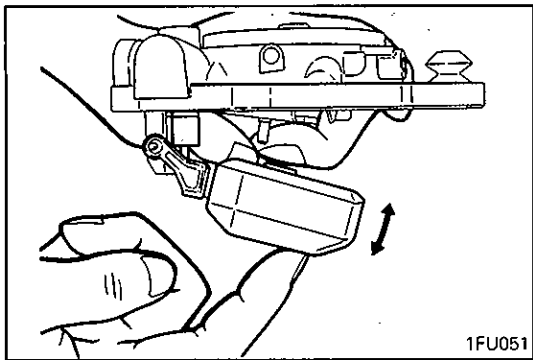

1FU051

- (3) Check that needle valve operates lightly. If the valve is hard to operate or is binding, repair or replace. If there is overflow, poor valve to seat contact is suspected. Check thoroughly.
- (4) Check the fuel inlet filter (located above the needle valve) for clogging and damage.
- (5) Check the float operation. Check float and lever for deformation and damage and replace if necessary.
- (6) Check operation of the throttle valve, choke valve and link. If they do not operate lightly, wash well and apply engine oil sparingly to their shaft.
- (7) Check the float chamber cover and main body for damage and cracks.

INSPECTION OF DASH POT (Conventional type)

- (1) Remove dash pot.
- (2) Push dash pot rod in lightly and confirm resistance.

NOTE

1. Resistance increases as the rod is pushed harder.
 2. If the rod can be pushed in with no resistance, either the diaphragm or check valve is faulty.
- (3) Release finger and confirm rod returns to its original position quickly.

NOTE

If rod returns slowly, the check valve is faulty.

INSPECTION OF DASH POT (CV type)

- (1) Check the dash pot diaphragm for damage. First, push the rod up fully and then, while securely closing the nipple with a finger, release the rod. The diaphragm is okay if the rod does not return to the initial position while the nipple is closed. If the rod returns slowly or quickly, the diaphragm is damaged. Then, replace the dash pot.

INSPECTION OF DIAPHRAGM CHAMBER

- (1) Check the diaphragm chamber diaphragm for damage. First, push up the rod fully and while closing the nipple securely with a finger, release the rod. The diaphragm is okay if the rod does not return to the initial position while the nipple is closed. If the rod returns slowly or quickly, the diaphragm is damaged. Then, replace the diaphragm chamber.

INSPECTION OF MIXTURE ADJUSTING SCREW (MAS)

- (1) Check tapered end of mixture adjusting screw (MAS) for damage from overtightening, etc.

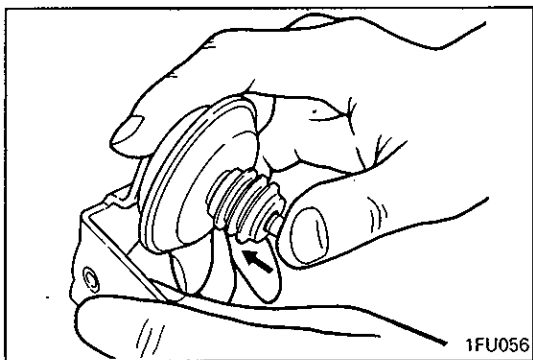

1FU056

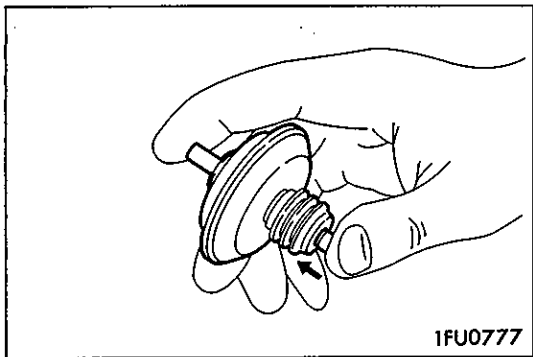

1FU077

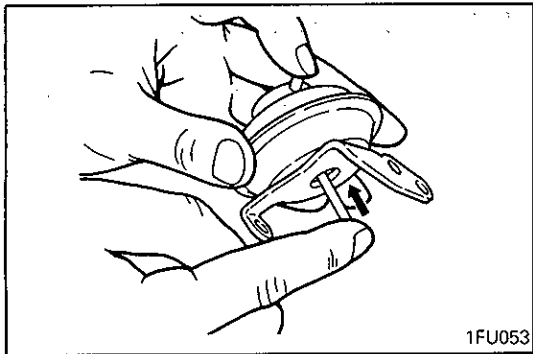

1FU053

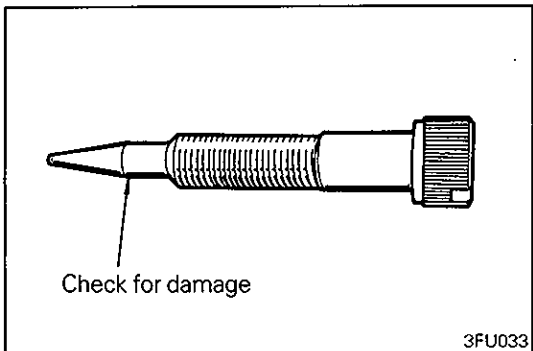

3FU033

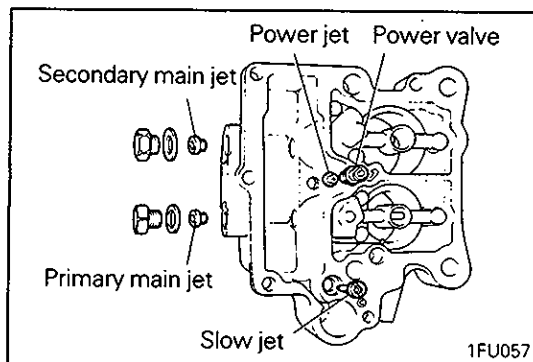

SERVICE POINTS OF REASSEMBLY

▶▶ INSTALLATION OF POWER JET / POWER VALVE / SLOW JET / MAIN JETS

- (1) When replacing a main or a slow jet, the old jet and the new jet must be of the same size, because the jet is selected after exact flow measurement by factory (a No. is stamped on each jet.)
- (2) Install main jets and slow jet.
Primary main jet is brass-colored (yellow) and secondary main jet is white.
- (3) Main jets and slow jet have jet size symbols stamped on their ends for identification.

NOTE

Refer to the table in GENERAL SPECIFICATIONS for the size symbols.

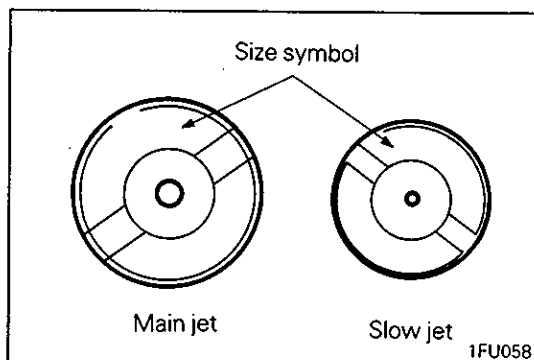

▶▶ INSTALLATION OF PUMP PLUNGER

- (1) When inserting the pump plunger, make sure that the cup is not turned back. Replace the cup if deformed or hardened.

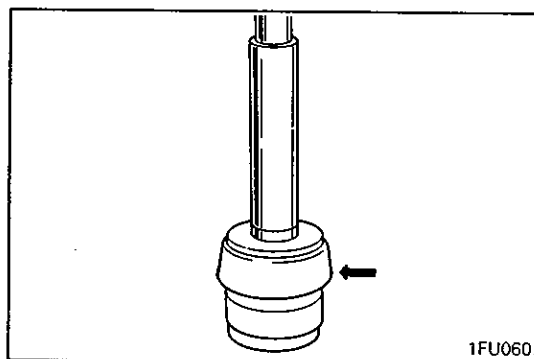

▶▶ INSTALLATION OF FLOAT / FLOAT PIN

- (1) When assembling these parts, make the float level adjustment.
- (2) For adjustment of the float level, see the following.

▶▶ INSTALLATION OF CHECK BALL (INLET) / RETAINER / CHECK BALL (OUTLET) / SPRING / WEIGHT

- (1) Install in the correct sequence and at the correct positions.

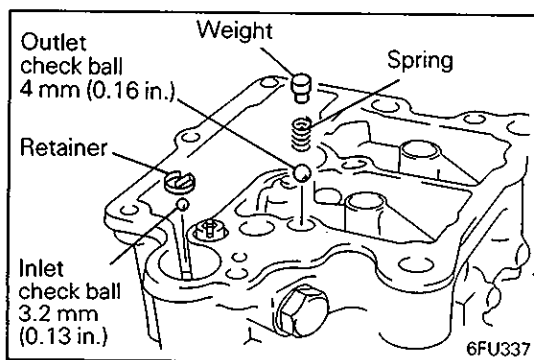

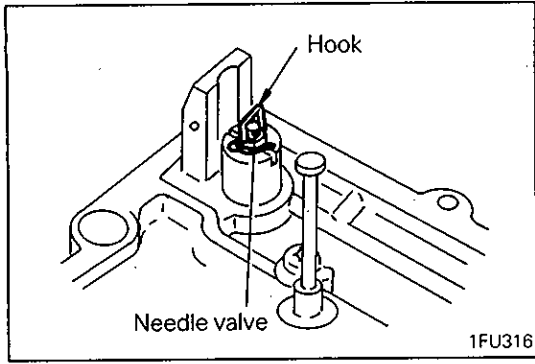

ADJUSTMENT OF FLOAT LEVEL

- (1) With the air horn turned-upside down, remove the hook attached to the needle valve.
- (2) Attach the float and pin.

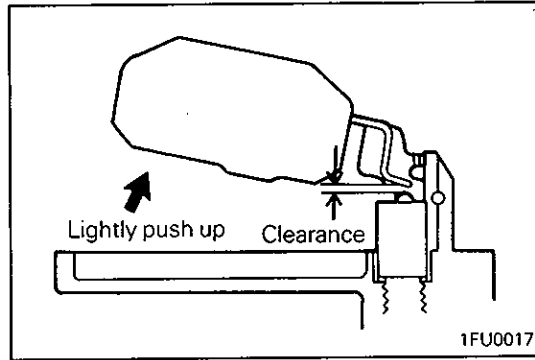

- (3) Lightly push up the float until it stops and measure the clearance between the needle valve and float lever.

Standard value: 1.5 – 1.7 mm (0.059 – 0.067 in.)
(1.5 mm φ wire gap gauge must be able to be inserted)

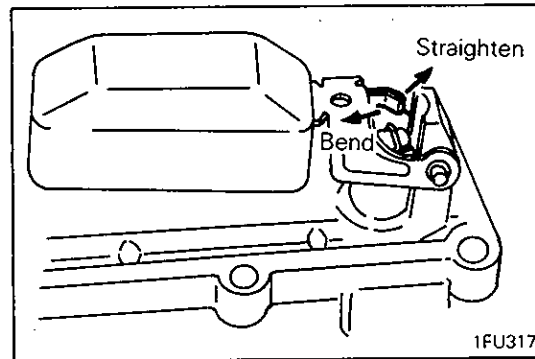

- (4) If the clearance is out of specification, adjust by bending or straightening the stopper indicated in illustration.

	Clearance
When stopper is bent	Greater
When stopper is straightened	Smaller

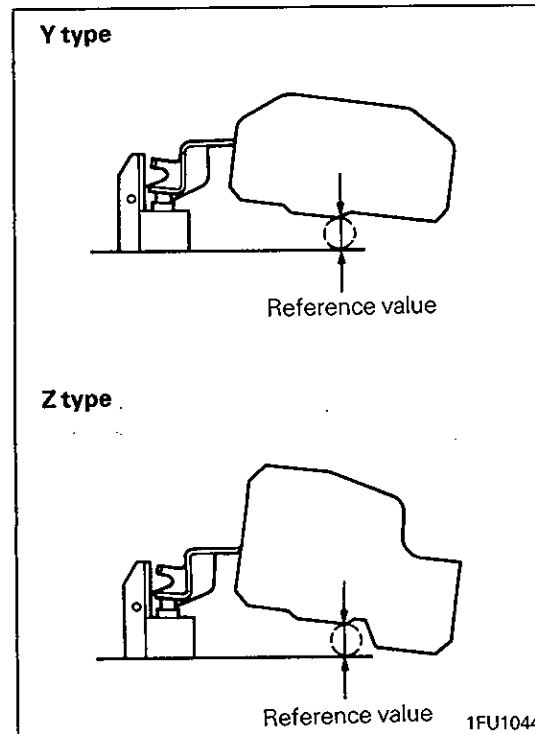

- (5) With the float at the position, to which it is lowered by its own weight, check for float to air horn clearance.

Reference value:

Y type Approx. 8.0 mm (0.31 in.)
Z type Approx. 7.4 mm (0.30 in.)

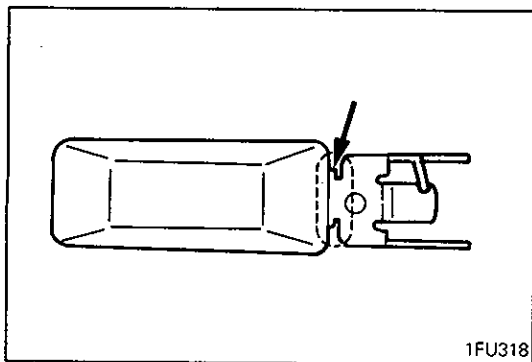

- (6) If the clearance is not up to the specified reference value, adjust by bending the portion indicated in illustration.
- (7) Remove the float and attach the hook to the needle valve.
- (8) Install the float, while hooking the float claw to the hook.

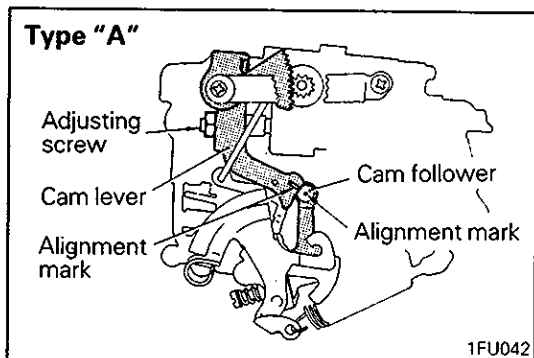

INSPECTION AND ADJUSTMENT AFTER REASSEMBLY

FAST IDLE OPENING

- (1) Before the inspection and adjustment, leave the unit in a room at 18°C (64.4°F) or lower for an hour or longer and then leave the carburetor in a room at about 23°C (73.4°F) for an hour or longer. (Type "A" carburetor)
- (2) Make sure that the alignment mark (engraved) on the cam lever is lined up with the alignment mark (punched) on the cam follower. (Type "A" carburetor)

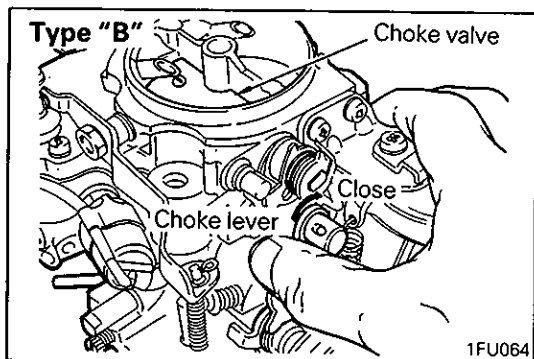

- (3) Move the choke lever to place the choke valve in fully closed position. (Type "B" carburetor)

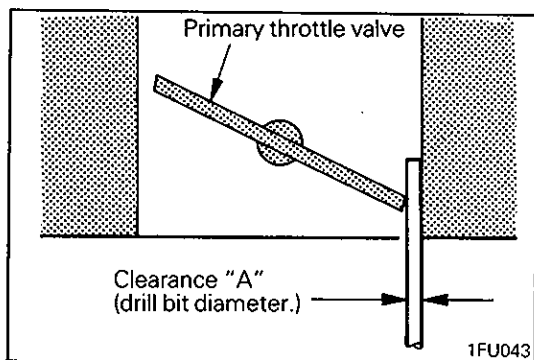

- (4) Measure the clearance (primary valve to throttle bore).

NOTE

Refer to the table in SERVICE SPECIFICATIONS for the clearance.

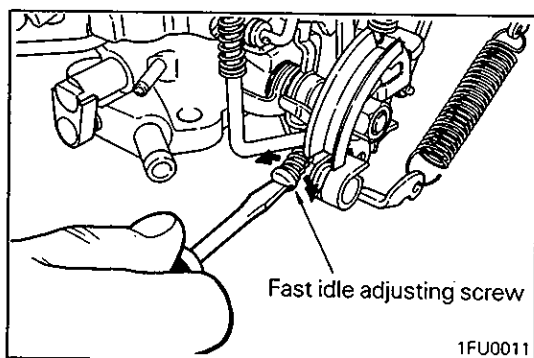

- (5) If the clearance is out of specifications, adjust to the standard value by the fast idle adjusting screw.

Screw direction of rotation	Clearance	Remarks
Clockwise	Increases	Fast idle speed increases
Counterclockwise	Decreases	Fast idle speed decreases

CHOKE VALVE OPERATION

- (1) Move the choke valve with a finger to make sure that the choke valve shaft has not an excessive play and the valve moves smoothly without sticking.
- (2) If the choke valve cannot be moved smoothly, clean the choke valve and the area around it.
- (3) If the play of the choke valve shaft is excessive, replace the air horn.

SECONDARY THROTTLE VALVE OPERATION

- (1) With the primary throttle valve fully opened, move the secondary throttle valve lever with a finger to make sure that the secondary throttle valve shaft has not an excessive play and the secondary throttle valve moves smoothly without sticking.
- (2) If the secondary throttle valve cannot be moved smoothly, clean the valve and the area around it, and then apply a small amount of engine oil to the shaft.
- (3) If the play of the secondary throttle valve shaft is excessive, replace the throttle body.

PORTS

- (1) Connect a hand vacuum pump and check each port for clogging.
- (2) If clogged, clean the port and then blow air into it.

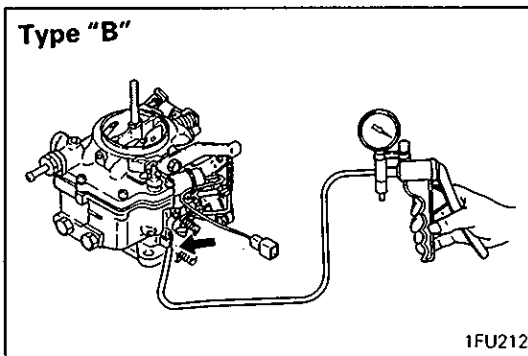
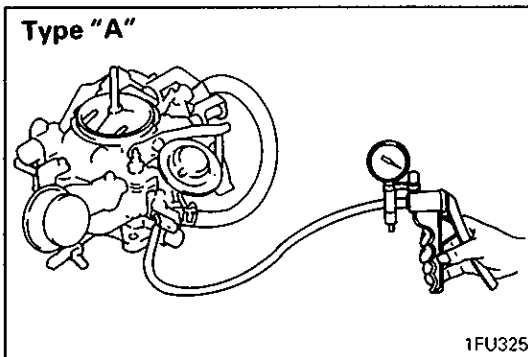

6. CARBURETOR – Types "C" and "D"

DISASSEMBLY AND REASSEMBLY – Type "C"

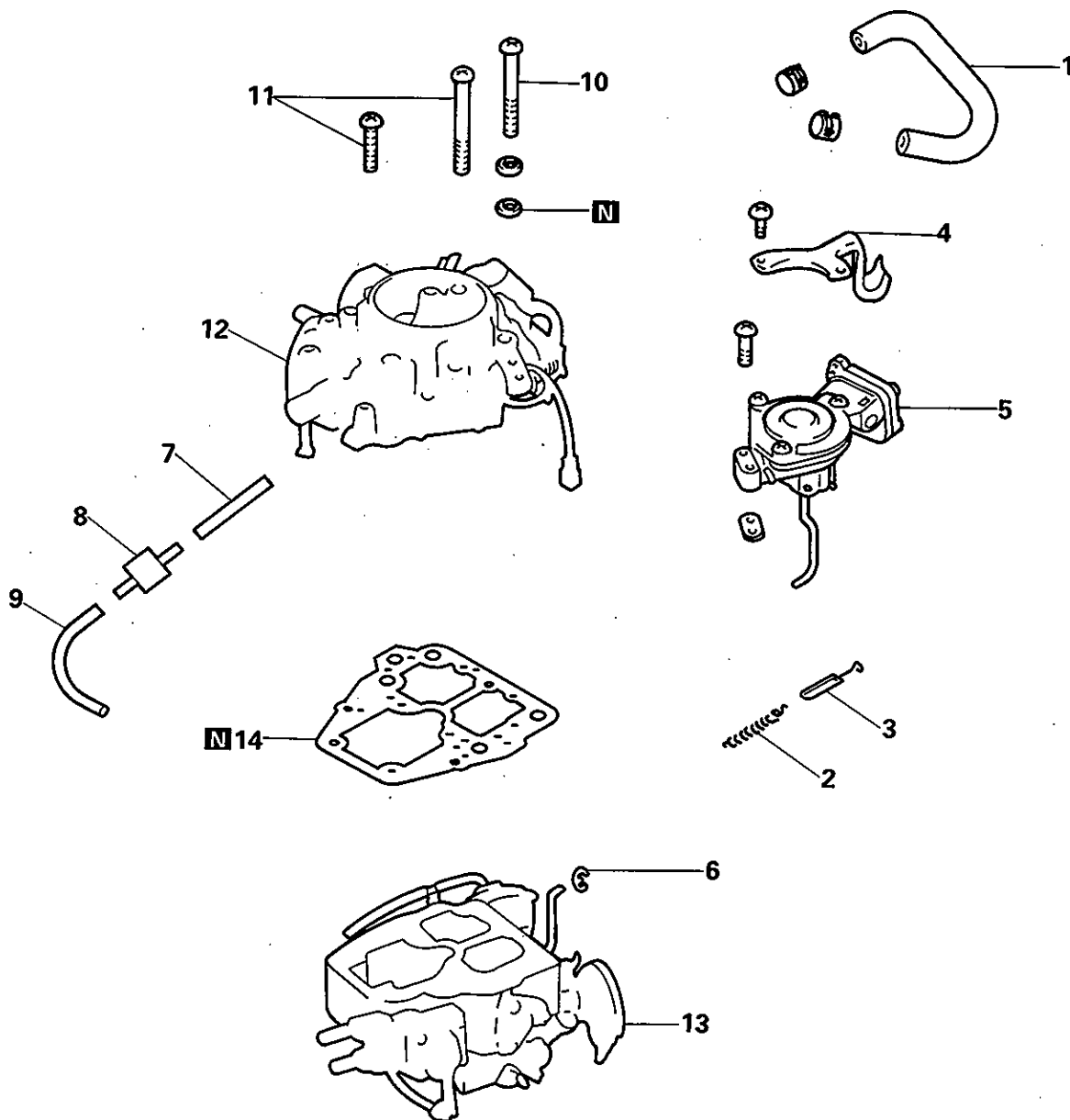

Disassembly steps

1. Water hose
2. Throttle-return spring
3. Rubber damper
4. Throttle-return spring bracket
5. Dashpot
- ◊A◊ 6. E-ring (choke rod upper)
7. Hose
8. Delay valve
9. Hose
- ◊E◊ 10. Screw, float chamber cover
- ◊B◊ 11. Screw, washer assembled
- ◊C◊ 12. Float chamber cover
13. Mixing body and throttle body
14. Gasket

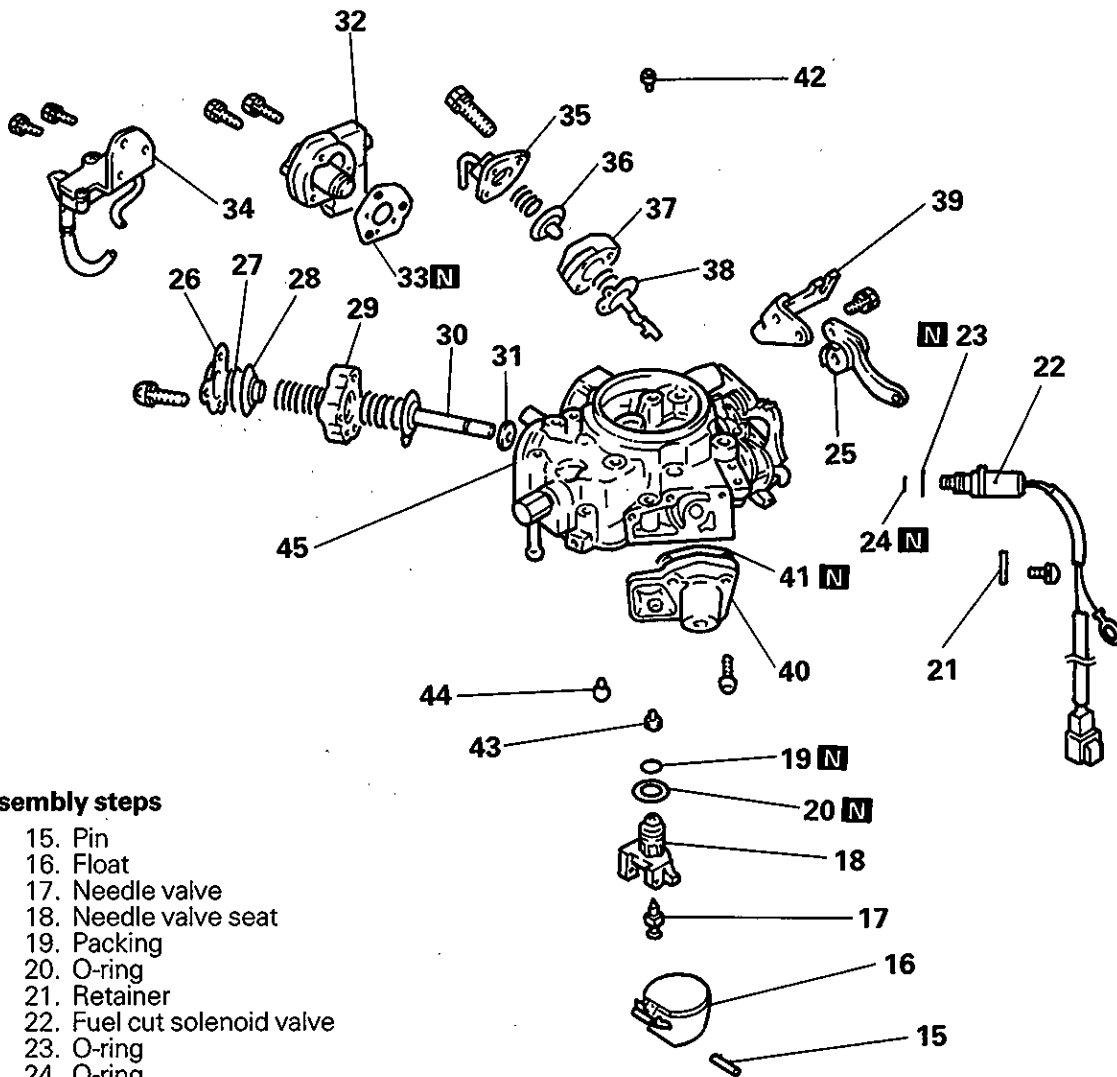

Disassembly steps

- 15. Pin
- 16. Float
- 17. Needle valve
- ◊D◊ 18. Needle valve seat
- ◊D◊ 19. Packing
- ◊D◊ 20. O-ring
- ◊D◊ 21. Retainer
- ◊D◊ 22. Fuel cut solenoid valve
- ◊D◊ 23. O-ring
- ◊D◊ 24. O-ring
- ◊E◊ ◊D◊ 25. Arm and pinion
- 26. Cover
- 27. Diaphragm
- 28. Spring seat
- 29. Body
- 30. Diaphragm
- 31. Valve
- 32. Mixture control valve assembly
- 33. Gasket
- 34. Idle compensator
- 35. Cover
- 36. Diaphragm
- 37. Body
- 38. Diaphragm
- 39. Bracket
- 40. Servo valve
- 41. Gasket
- ◊C◊ 42. Main air jet
- ◊C◊ 43. Pilot jet (primary)
- ◊C◊ 44. Pilot jet (secondary)
- 45. Float chamber cover

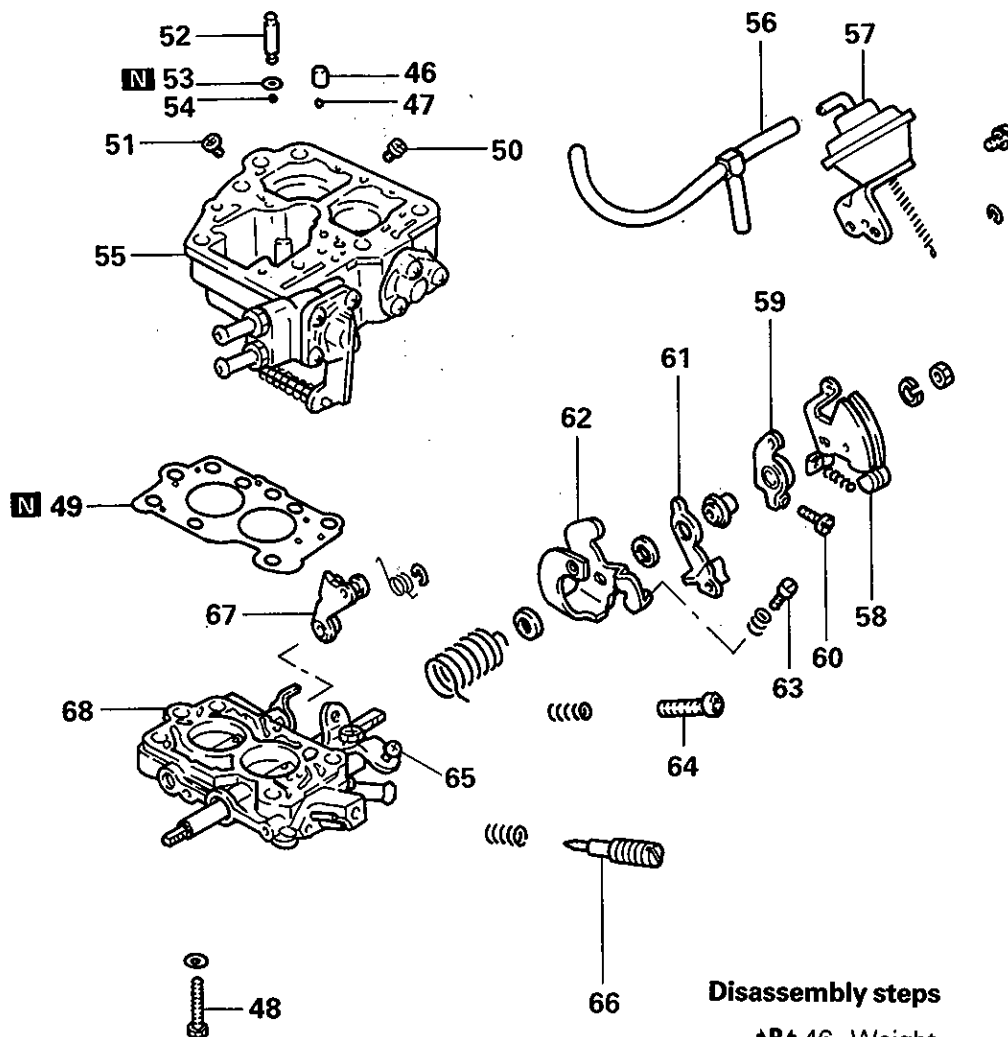

Disassembly steps

- ▶B▶ 46. Weight
- ▶B▶ 47. Ball
- ◊F◊ 48. Screw
- 49. Gasket
- ▶A▶ 50. Main jet
- ▶A▶ 51. Main jet
- ◊G◊▶B▶ 52. Plug
- ◊G◊▶B▶ 53. O-ring
- ◊G◊▶B▶ 54. Ball
- 55. Mixing body
- 56. Hose
- 57. Depression chamber
- 58. Throttle lever
- 59. Cam follower
- 60. Fast idle adjusting screw
- 61. Free lever
- 62. Abutment plate
- 63. Idle speed adjusting screw (SAS-2)
- 64. Idle speed adjusting screw (SAS-1)
- 65. Dash pot adjusting screw (SAS-3)
- ◊H◊ 66. Mixture adjusting screw (MAS)
- 67. Secondary lever
- 68. Throttle body

DISASSEMBLY AND REASSEMBLY – Type “D”

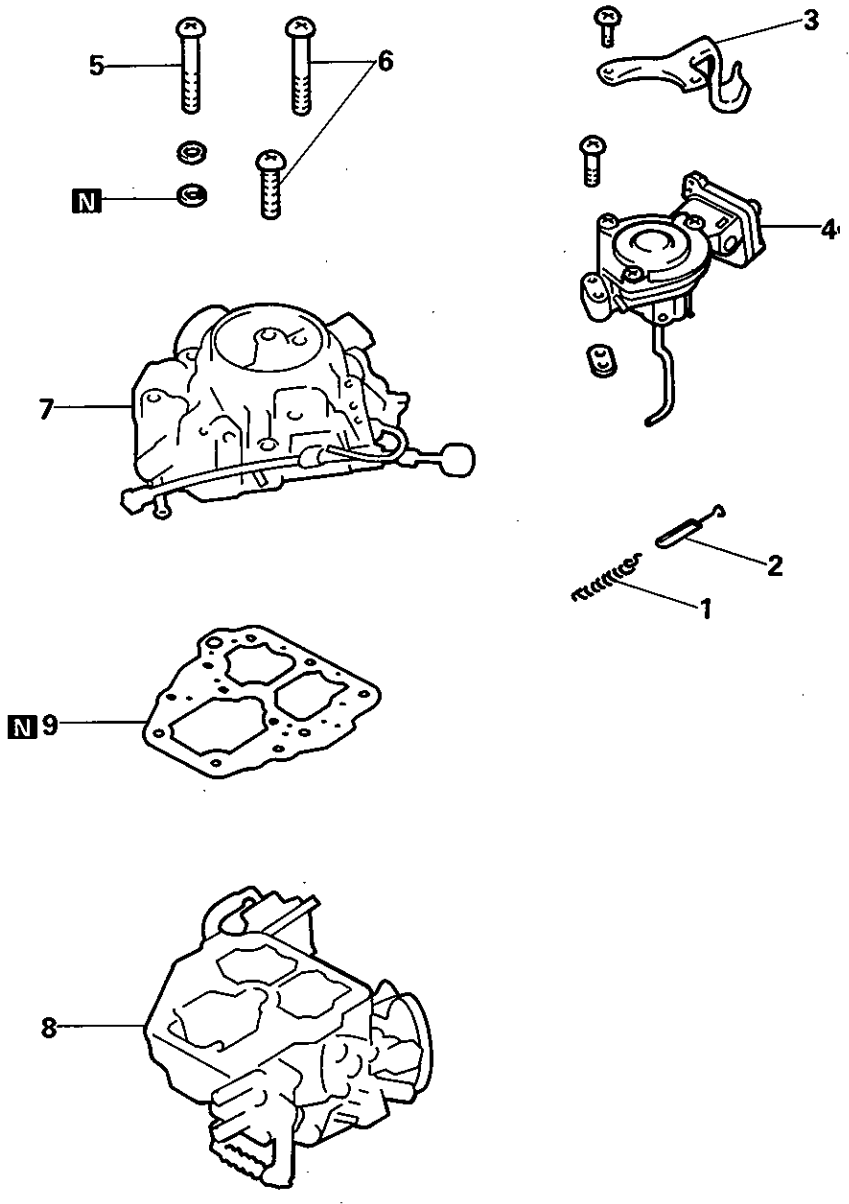

Disassembly steps

1. Throttle-return spring
2. Rubber damper
3. Throttle-return spring bracket
4. Dashpot
5. Screw, float chamber cover
6. Screw, washer assembled
7. Float chamber cover
8. Mixing body and throttle body
9. Gasket

◆E◆
 ◇B◇
 ◇C◇

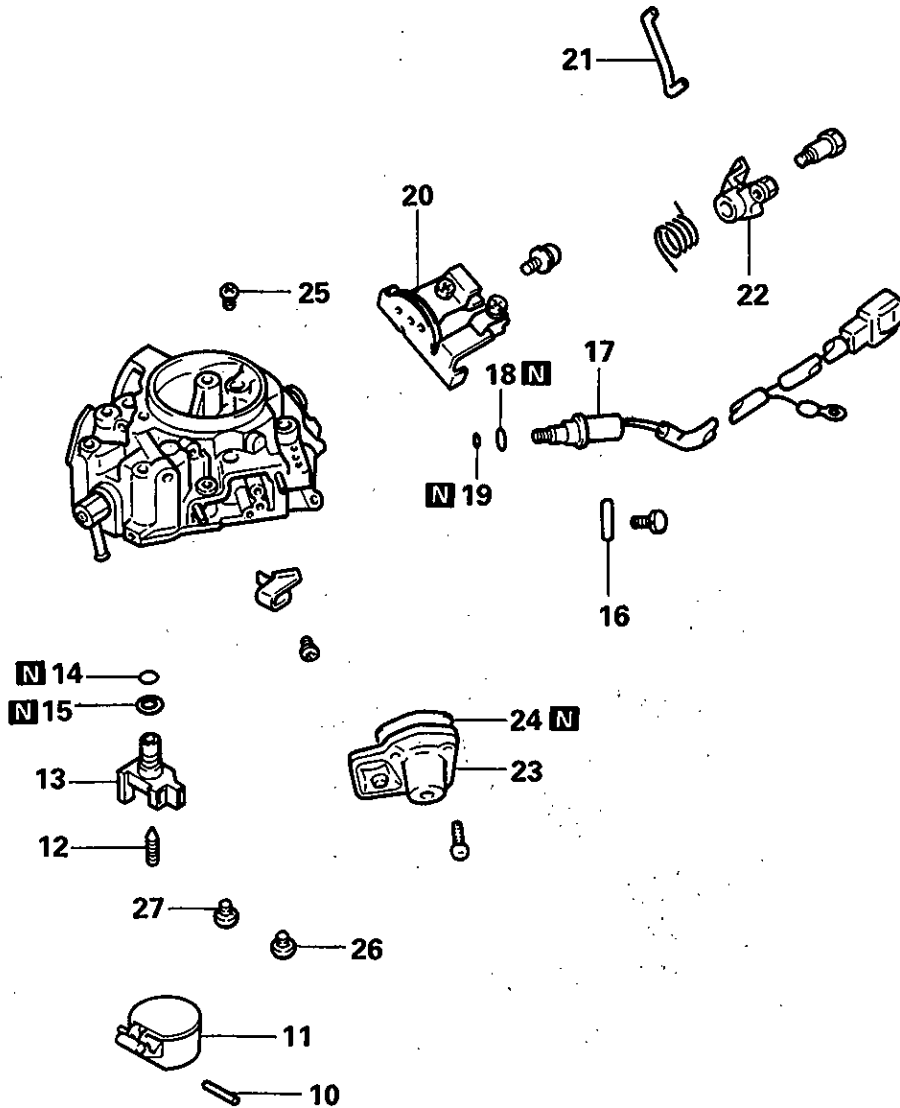

Disassembly steps

- 10. Pin
- 11. Float
- 12. Needle valve
- ◁D▷ 13. Needle valve seat
- 14. Packing
- 15. O-ring
- 16. Retainer
- 17. Fuel cut solenoid valve
- 18. O-ring
- 19. O-ring
- 20. Bracket
- 21. Choke rod
- 22. Choke lever
- 23. Servo valve
- 24. Gasket
- ◁C▷ 25. Main air jet
- ◁C▷ 26. Pilot jet (primary)
- ◁C▷ 27. Pilot jet (secondary)

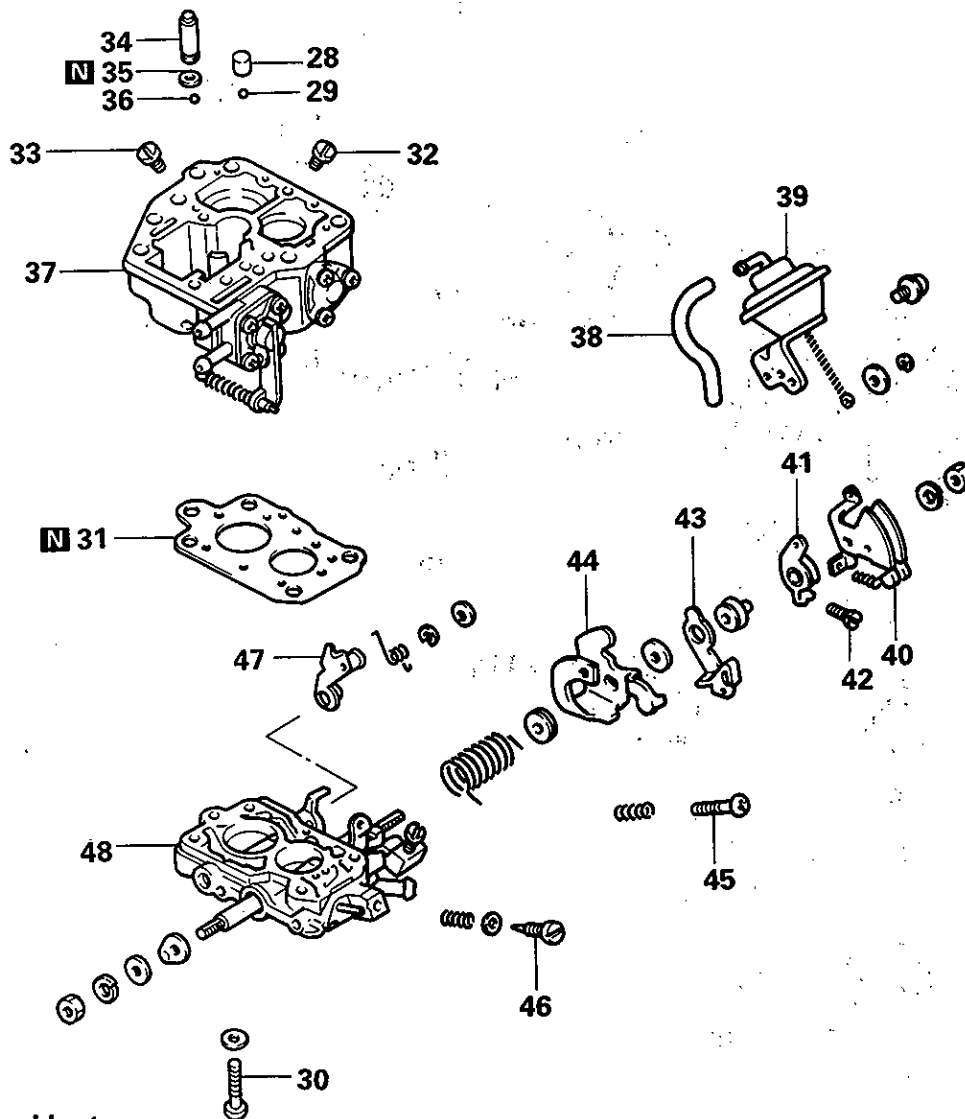

Disassembly steps

- ◆B◆ 28. Weight
- ◆B◆ 29. Ball
- ◇F◇ 30. Screw
- 31. Gasket
- ◆A◆ 32. Main jet
- ◆A◆ 33. Main jet
- ◇G◇ ◆B◆ 34. Plug
- ◇G◇ ◆B◆ 35. O-ring
- ◇G◇ ◆B◆ 36. Ball
- 37. Mixing body
- 38. Hose
- 39. Depression chamber
- 40. Throttle lever
- 41. Cam follower
- 42. Fast idle adjusting screw
- 43. Free lever
- 44. Abutment plate
- 45. Idle speed adjusting screw (SAS)
- ◇H◇ 46. Mixture adjusting screw (MAS)
- 47. Secondary lever
- 48. Throttle body

5FU0158

SERVICE POINTS OF DISASSEMBLY

Following parts must not be disassembled:

- (1) Choke valve, choke shaft and automatic choke system
- (2) Inner venturies
- (3) Throttle valve and throttle shaft
- (4) Fuel inlet nipple
- (5) Painted adjusting screw
- (6) Accelerator pump rod and round nut

When a cross-recessed screw is to be loosened, use a Phillips screwdriver of proper size as the screw is held tightly. When removing each jet, use a screwdriver which fits the slot exactly and work carefully so as not to damage the jet.

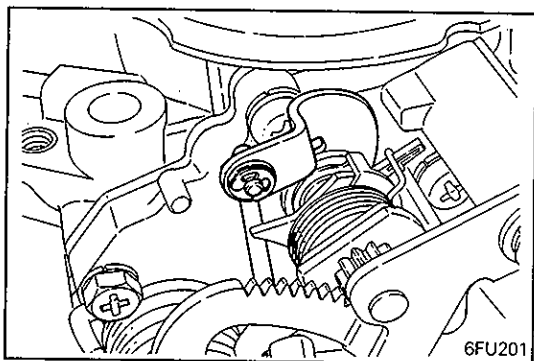

◊A◊ REMOVAL OF E-RING (CHOKE ROD UPPER)

- (1) Remove the E-ring from the choke rod upper to separate the choke rod upper from the choke valve lever.

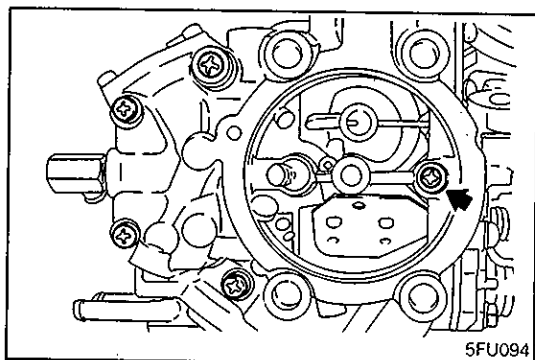

◊B◊ REMOVAL OF SCREW, WASHER ASSEMBLED

- (1) Remove five screws (four 65 mm long and one 45 mm long) tightening float chamber cover and mixing body together. Be sure to remove one screw that is located deep in boundary between primary and secondary bores.

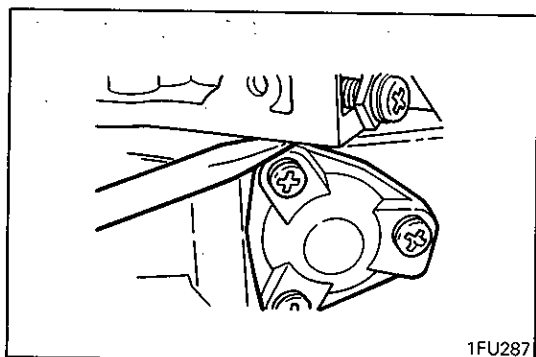

◊C◊ REMOVAL OF FLOAT CHAMBER COVER

- (1) Do not attempt to remove the cover at a time as it is held in position firmly by gasket. Insert a screwdriver blade between the enrichment cover and the float chamber cover as illustrated and lightly pry it up and lift up gently.

NOTE

Do not apply excessive force.

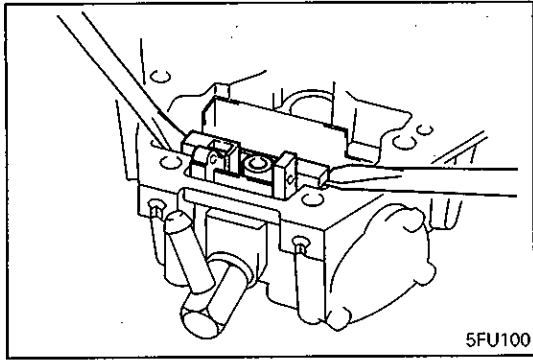

◊D◊ REMOVAL OF NEEDLE VALVE SEAT

- (1) Using screwdrivers, pry up the needle valve seat at both edges to remove.

Caution

- Use care not to damage the float chamber cover when pushing up the needle valve seat.

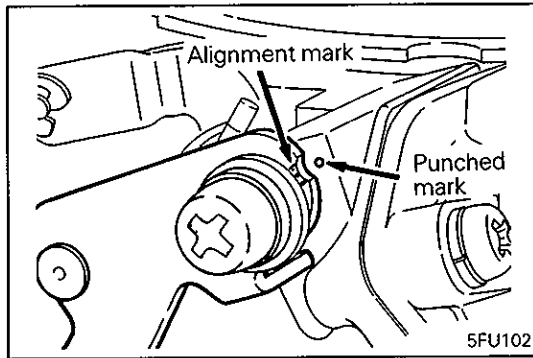

◊E◊ REMOVAL OF ARM AND PINION

- (1) Before removing the arm and pinion, note the location of alignment marks shown in the illustration.

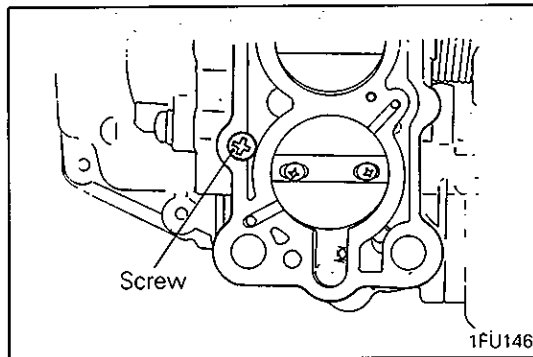

◊F◊ REMOVAL OF SCREW

- (1) Any damage (protrusion) to the screw head will result in a gap between the carburetor and the manifold mounting surface. Work carefully so as not to damage the screw head.

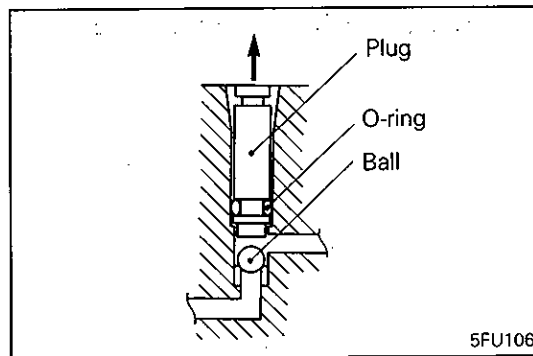

◊G◊ REMOVAL OF PLUG / O-RING / BALL

- (1) The plug has an O-ring at its tip and cannot be pulled out readily. Holding the plug with tweezers or the like and prying, pull out little by little.

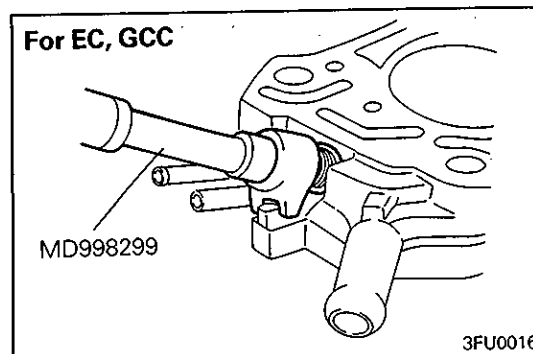

◊H◊ REMOVAL OF MIXTURE ADJUSTING SCREW (MAS) FOR EC, GCC

- (1) Using the special tool (MAS driver), remove the idle limiter cap and mixture adjusting screw.

INSPECTION

GENERAL INSPECTION

Check the following and repair or replace parts if faulty.

- (1) Check fuel passages (jets) and air passages (jets or orifices) for clogging. If clogged, wash thoroughly with cleaning solvent or detergent and remove dirt by compressed air. Do not use wire or other metal pieces.
- (2) Check diaphragms, O-rings and springs for damage and cracks.
- (3) Check that needle valve operates lightly. If the valve is hard to operate or is binding, repair or replace. If there is overflow, poor valve to seat contact is suspected. Check thoroughly.
- (4) Check the fuel inlet filter (located above the needle valve) for clogging and damage.
- (5) Check float operation. Check float and lever for deformation and damage and replace if necessary.
- (6) Check operation of throttle valve, choke valve and link. If they do not operate lightly, wash well and apply engine oil sparingly to their shaft.
- (7) Check the float chamber cover and mixing body for damage and cracks.

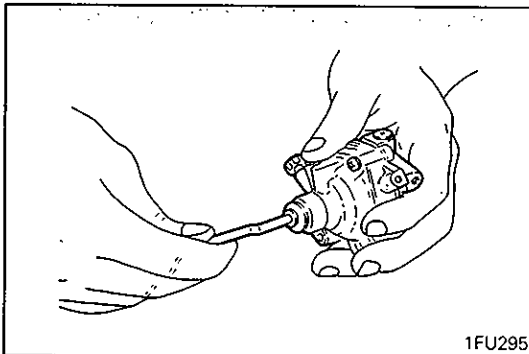

INSPECTION OF DASH POT

- (1) Check that the dash pot operates normally. Resistance must be felt when the dash pot is pulled, and when the dash pot is released, the rod must return quickly to original position. If no resistance is felt when it is pulled, diaphragm or check valve is broken. If the rod returns slowly, the check valve is broken. In either case, replace the dash pot.

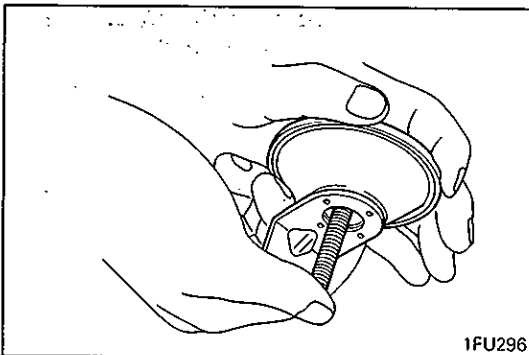

INSPECTION OF DEPRESSION CHAMBER

- (1) Check the depression chamber diaphragm for damage. First, push up the rod fully and closing the nipple tightly with a finger, release rod. Diaphragm is okay if the rod does not return to initial position while the nipple is held closed with a finger. If the rod returns slowly or quickly, diaphragm is broken. Then, replace the depression chamber.

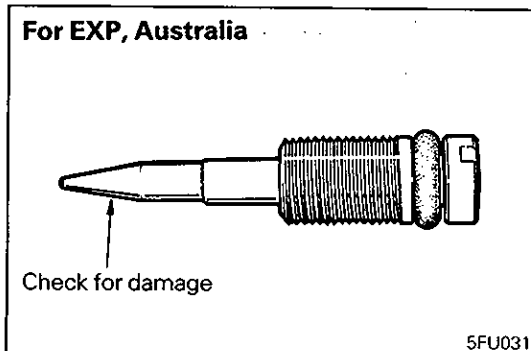

INSPECTION OF MIXTURE ADJUSTING SCREW

- (1) Check tapered end of mixture adjusting screw for damage from overtightening, etc.

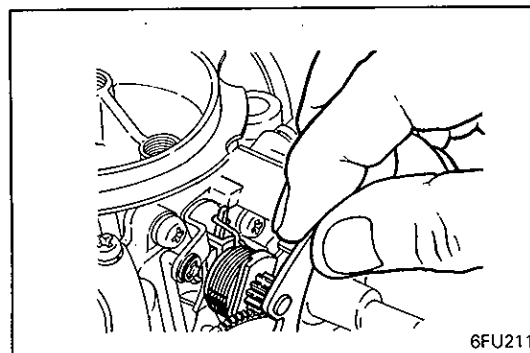
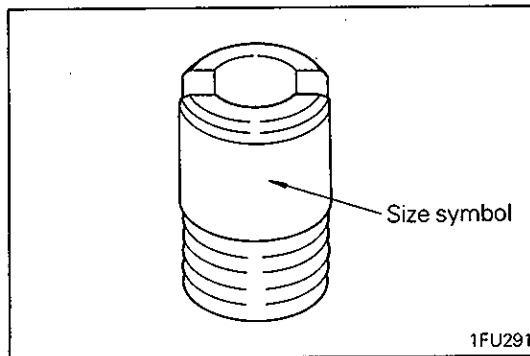
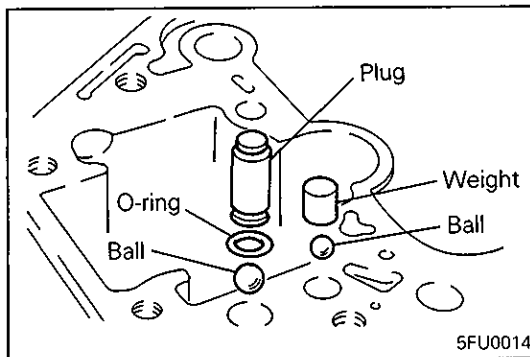
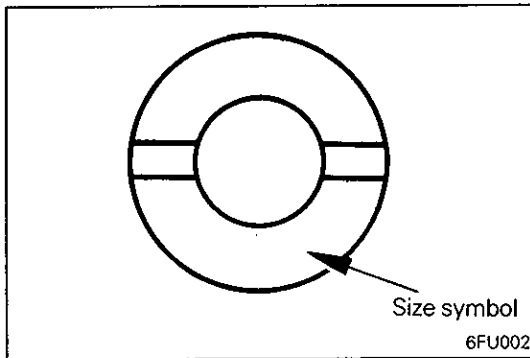
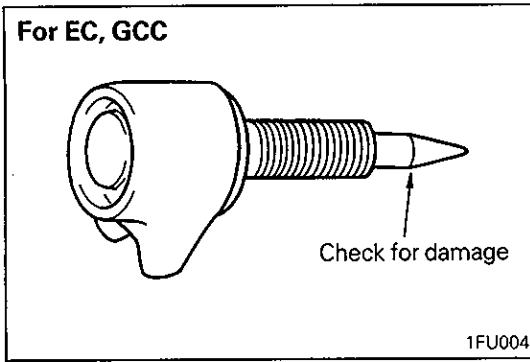

SERVICE POINTS OF REASSEMBLY

▶▶ INSTALLATION OF MAIN JETS

- (1) Make sure that correct jets are installed at correct positions. Note size symbol stamped on each jet for identification.

NOTE

Refer to the table in GENERAL SPECIFICATIONS for the size symbols.

▶▶ INSTALLATION OF BALL / O-RING / PLUG / BALL / WEIGHT

- (1) Install in correct sequence and at correct positions.

▶▶ INSTALLATION OF PILOT JET (SECONDARY) / PILOT JET (PRIMARY) / MAIN AIR JET

- (1) Make sure that correct jets are installed at correct positions. Note size symbol stamped on each jet for identification.

NOTE

Refer to the table in GENERAL SPECIFICATIONS for the size symbols.

▶▶ INSTALLATION OF ARM AND PINION

- (1) Install the strangler spring over the choke lever.

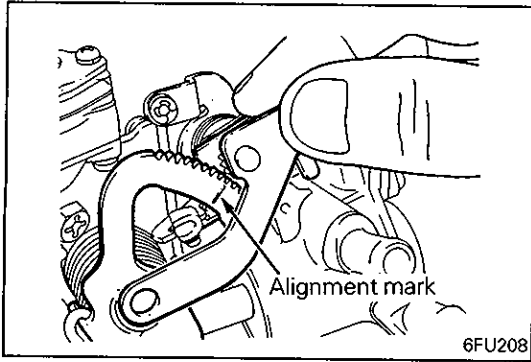

- (2) Install the arm and pinion, aligning the cam lever alignment mark with the choke pinion alignment mark.

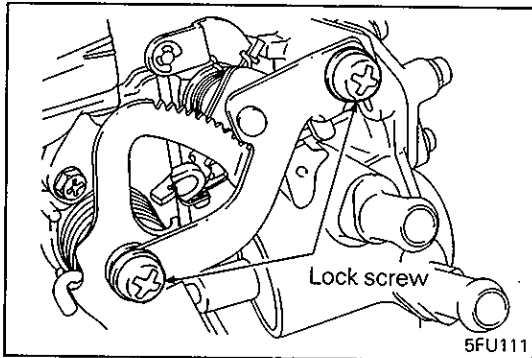

- (3) Tighten lock screws temporarily.

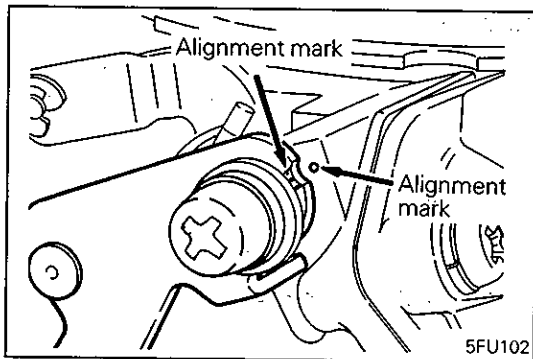

- (4) Slide the pinion vertically to set the alignment mark at position noted at time of disassembly.
- (5) Tighten lock screws.

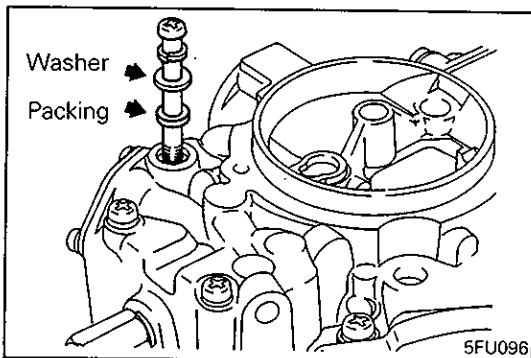

▶E▶ INSTALLATION OF SCREW, FLOAT CHAMBER COVER

- (1) Be sure to install the packing and washer correctly to prevent fuel leaks.

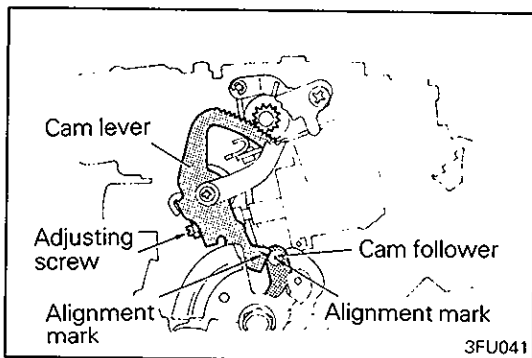

INSPECTION AND ADJUSTMENT AFTER ASSEMBLY

FAST IDLE OPENING (Type “C” carburetor)

- (1) Prior to adjustment, keep the carburetor in a room at temperature below 18°C (64.4°F) for an hour or longer and then keep it in a room at temperature about 23°C (73.4°F) for an hour or longer.
- (2) Check that alignment mark engraved on the cam lever is lined up with alignment mark punched on the cam follower.

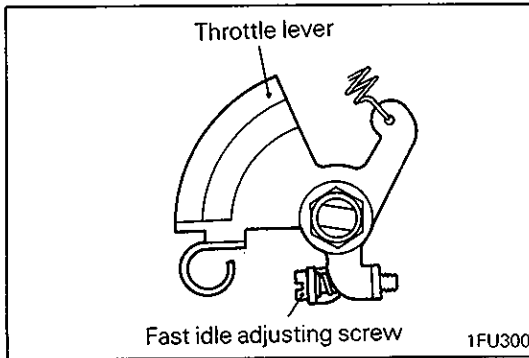
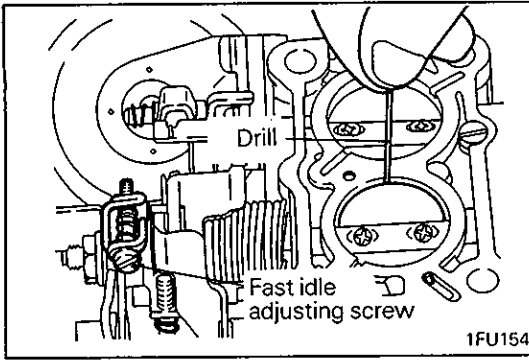

(3) Measure primary valve to throttle bore clearance.

NOTE

Refer to the table in SERVICE SPECIFICATIONS for clearance.

(4) If clearance is out of specification, adjust fast idle adjusting screw to obtain standard value.

Direction of adjusting screw rotation	Clearance	Fast idle speed
Clockwise	Large	Increases
Counterclockwise	Small	Decreases

CHOKE VALVE OPERATION

- (1) Move the choke valve with a finger to make sure that the choke valve shaft has not an excessive play and the valve moves smoothly without sticking.
- (2) If the choke valve cannot be moved smoothly, clean the choke valve and the area around it.
- (3) If the play of the choke valve shaft is excessive, replace the air horn.

SECONDARY THROTTLE VALVE OPERATION

- (1) With the primary throttle valve fully opened, move the secondary throttle valve lever with a finger to make sure that the secondary throttle valve shaft has not an excessive play and the secondary throttle valve moves smoothly without sticking.
- (2) If the secondary throttle valve cannot be moved smoothly, clean the valve and the area around it, and then apply a small amount of engine oil to the shaft.
- (3) If the play of the secondary throttle valve shaft is excessive, replace the throttle body.

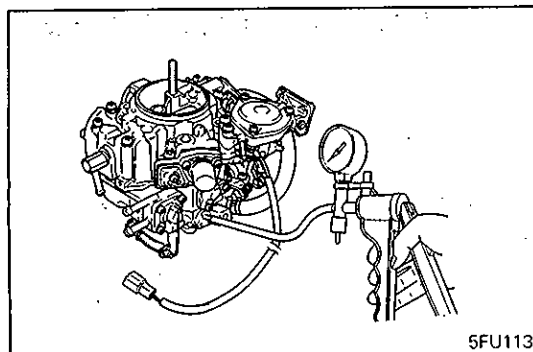

PORTS

- (1) Connect a hand vacuum pump and check each port for clogging.
- (2) If clogged, clean the port and then blow air into it.