

EMISSION CONTROL SYSTEM

CONTENTS

1. SPECIFICATIONS	17A-1-1
GENERAL SPECIFICATIONS	17A-1-1
SERVICE SPECIFICATIONS	17A-1-1
TORQUE SPECIFICATIONS	17A-1-1
SEALANTS	17A-1-1
2. PARTS LOCATION	17A-2-1
3. INSPECTION	17A-3-1
EGR VALVE	17A-3-1
COOLANT TEMPERATURE SENSOR	17A-3-1
COOLANT TEMPERATURE SWITCH	17A-3-2

1. SPECIFICATIONS

GENERAL SPECIFICATIONS

EGR valve	Single type
Coolant temperature sensor	Thermistor type
Coolant temperature switch	Thermo ferrite type

NOTE

The emission control systems differ in their specifications depending on the models and destinations. From the emission control parts listed in the GENERAL SPECIFICATIONS, the optimum ones have been selected and installed. Refer to the Workshop Manuals of specific models, therefore, for the description of parts that have been mounted.

SERVICE SPECIFICATIONS

EGR valve

Valve closing check pressure	20 mmHg (0.8 inHg)
Valve opening check pressure	570 mmHg (22.6 inHg)

Coolant temperature sensor

Resistance	At 0°C (32°F)	8.6 kΩ
	At 20°C (68°F)	3.3 kΩ
	At 40°C (104°F)	1.5 kΩ
	At 80°C (176°F)	0.3 kΩ

TORQUE SPECIFICATIONS

	Nm	Torque	
		kgm	ft.lbs.
EGR valve attaching bolt	25	2.5	18
Coolant temperature sensor	35	3.5	26
Coolant temperature switch	8	0.8	5.8

SEALANTS

	Specified sealant	Quantity
Coolant temperature sensor threaded part	3M NUT Locking Part No. 4171 or equivalent	As required
Coolant temperature switch threaded part	3M ATD Part No. 8660 or equivalent	As required

121

NOTES

2. PARTS LOCATION

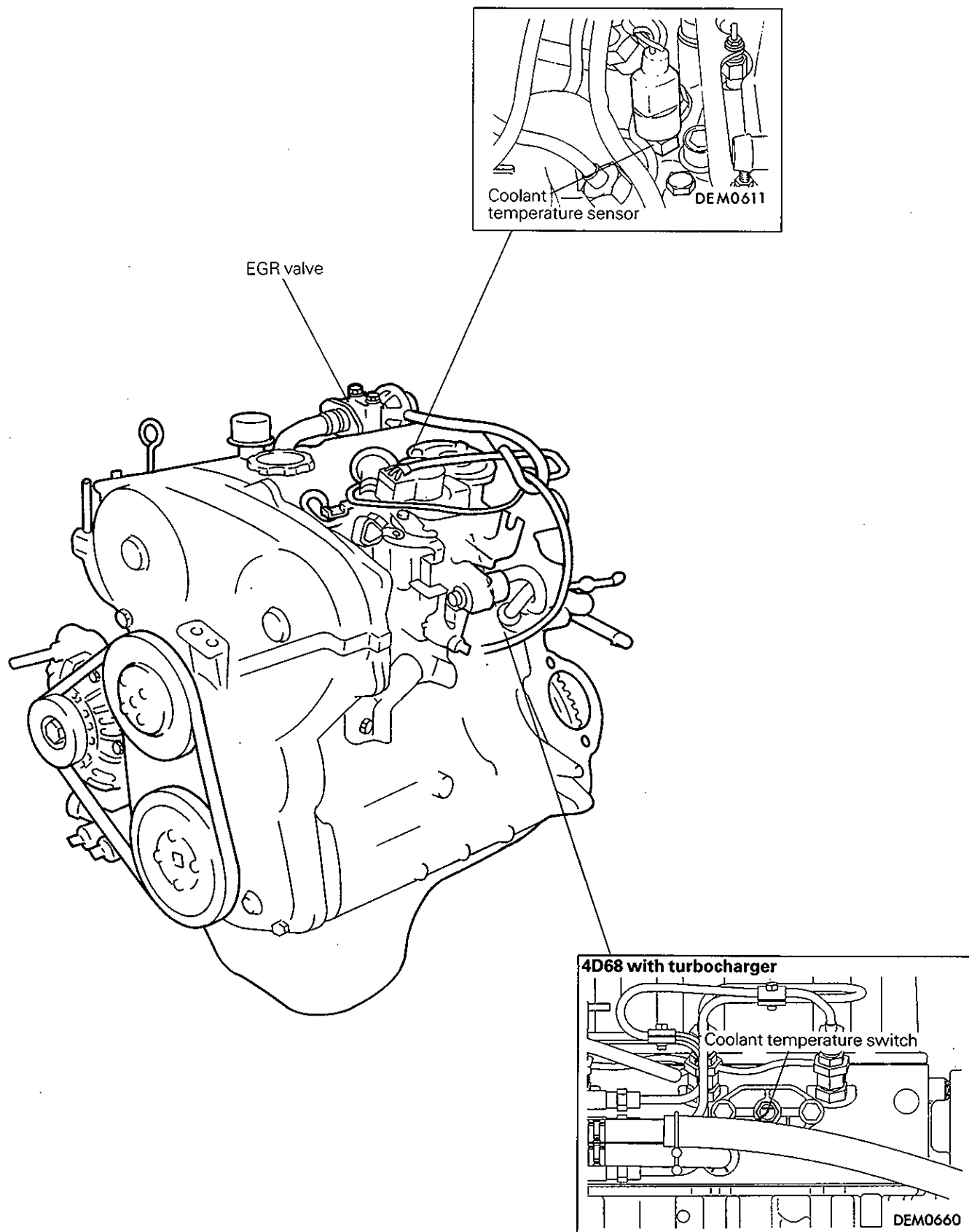

NOTES

3. INSPECTION

EGR VALVE

- (1) Remove the EGR valve and check it for sticking, deposit of carbon, etc.
If such condition exists, clean with adequate solvent to ensure correct valve seat contact.

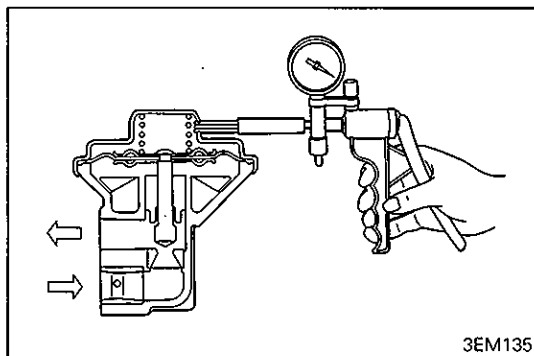

- (2) Connect a hand vacuum pump to the EGR valve.
- (3) Apply a vacuum of 500 mmHg (19.7 inHg) and check air tightness.
- (4) Blow in air from one passage of the EGR to check condition as follows.

Vacuum	Normal condition
20 mmHg (0.8 inHg) or lower	Air does not blow through
570 mmHg (22.4 inHg) or higher	Air blows through

- (5) Replace the gasket with a new one and tighten the EGR valve to specified torque.

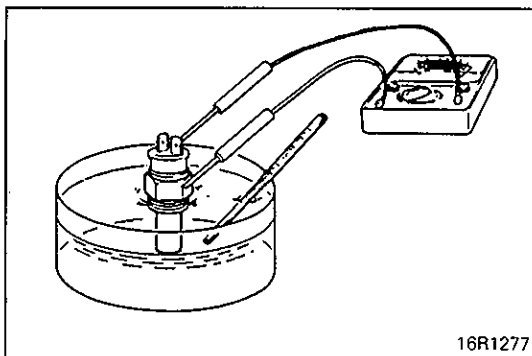

COOLANT TEMPERATURE SENSOR

- (1) Remove the coolant temperature sensor.
- (2) Immerse the temperature sensing section in water and measure resistance between terminals 2 and body while heating the water.

Temperature °C (°F)	Resistance (kΩ)
0 (32)	8.6
20 (68)	3.3
40 (104)	1.5
80 (176)	0.3

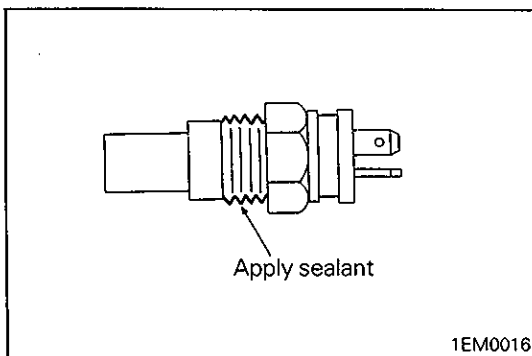

- (3) If the resistance deviates greatly from the standard value, replace the coolant temperature sensor.
- (4) Apply sealant to threaded portion.

Specified sealant:

3M NUT Locking No. 4171 or equivalent

- (5) Install the coolant temperature sensor and tighten it to specified torque.

132

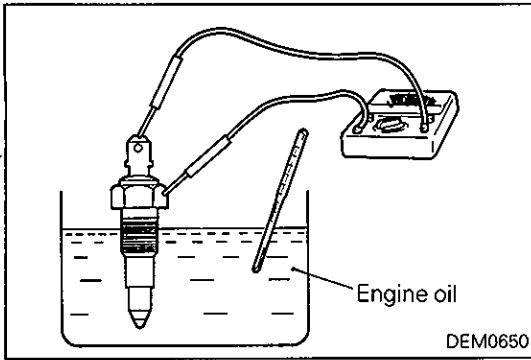
**COOLANT TEMPERATURE SWITCH**

- (1) Remove the coolant temperature switch.
- (2) With the temperature sensing element of the coolant temperature switch immersed in engine oil, check for continuity.

Engine oil temperature	Continuity
100°C (230°F) or less	Not present
120°C (248°F) or less	Present

- (3) If the coolant temperature switch does not operate normally, replace the switch.
- (4) Apply sealant to threaded portion.

Specified sealant:**3M ATD Part No. 8660 or equivalent**

- (5) Install the coolant temperature switch and tighten it to specified torque.

