

ENGINE ELECTRICAL

STARTING SYSTEM

CONTENTS

GENERAL INFORMATION	16B- 0- 3
1. SPECIFICATIONS	16B- 1- 1
SERVICE SPECIFICATIONS	16B- 1- 1
TORQUE SPECIFICATIONS	16B- 1- 1
2. STARTER MOTOR — REMOVAL AND INSTALLATION	16B- 2- 1
3. STARTER MOTOR <EXCEPT 4M40 ENGINE>	
— DISASSEMBLY AND REASSEMBLY	16B- 3- 1
4. STARTER MOTOR <4M40 ENGINE>	
— DISASSEMBLY AND REASSEMBLY	16B- 4- 1



GENERAL INFORMATION

Direct Drive Type

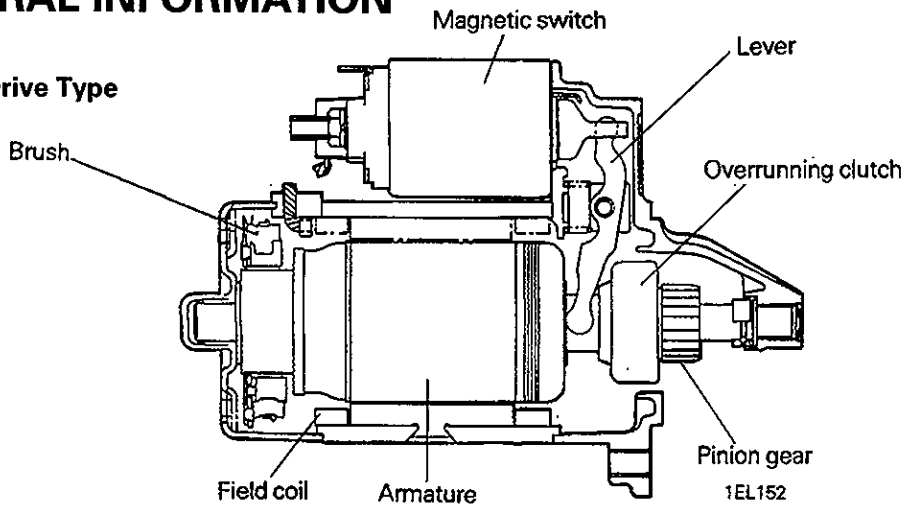

Spur Gear Reduction Drive Type

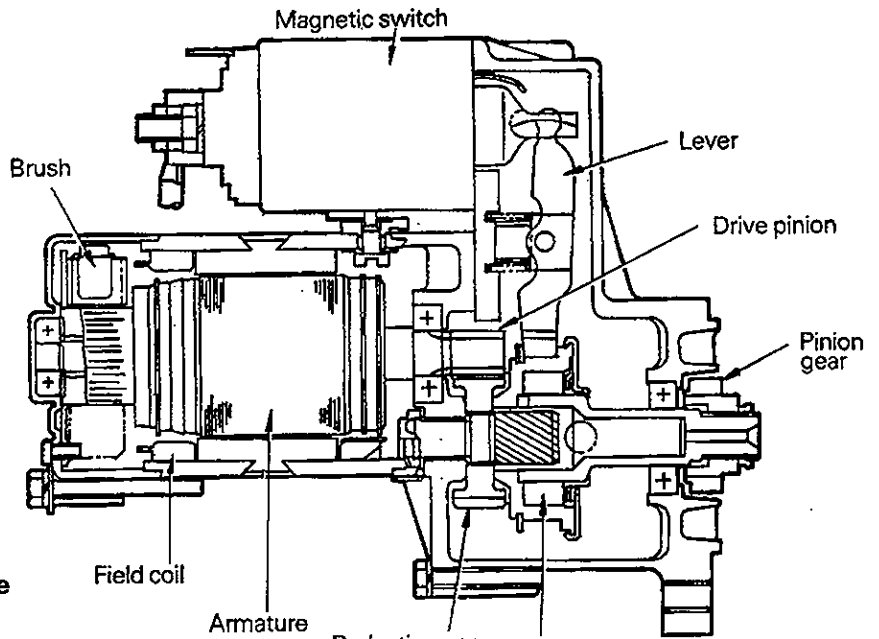

Planetary Gear Reduction Drive Type (For Petrol Engine)

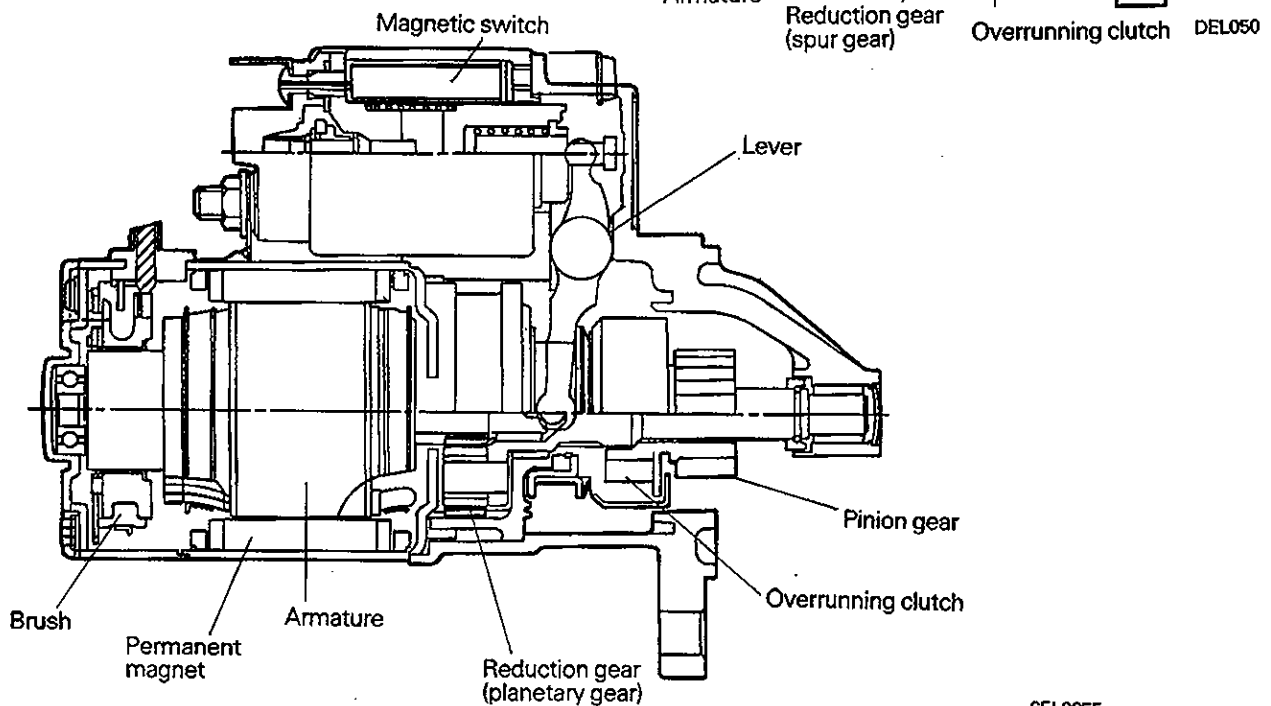

6EL0055

Planetary Gear Reduction Drive Type
(For Diesel Engine)

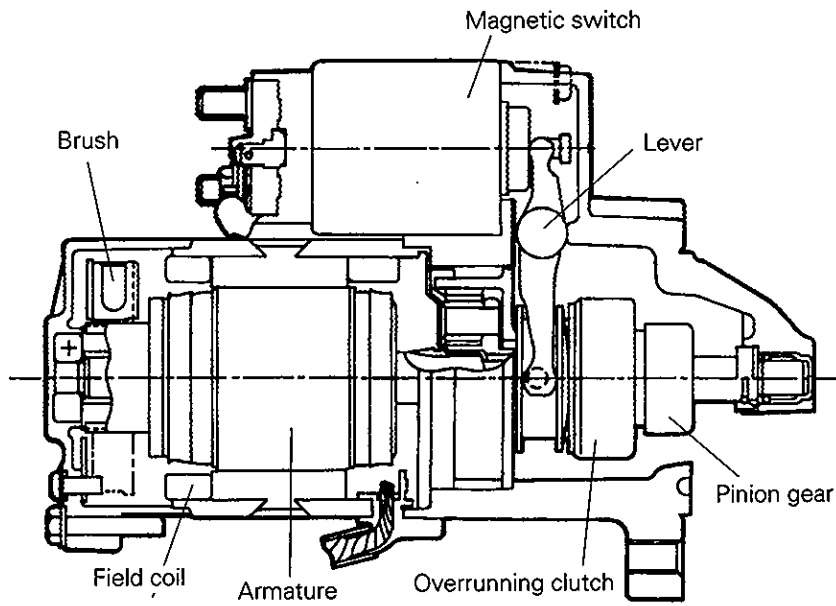

DEN0173

1. SPECIFICATIONS

SERVICE SPECIFICATIONS

mm (in.)

	Standard	Limit
<Except 4M40 engine>		
Commutator		
Outer diameter		
Direct drive type and spur gear reduction drive type, planetary gear reduction drive type (For diesel engine)	32.0 (1.26)	31.0 (1.22)
Planetary gear reduction drive type (For petrol engine)	29.4 (1.16)	28.4 (1.12)
Runout	Max. 0.05 (0.0020)	0.1 (0.004)
Pinion gap	0.5 – 2.0 (0.020 – 0.079)	
Undercut	0.5 (0.020)	0.2 (0.008)
<4M40 engine>		
Pinion shaft assembly thrust gap	0.1 – 0.5 (0.004 – 0.020)	
Pinion gap	0.5 – 2.0 (0.020 – 0.079)	
Magnet switch activating voltage	Less than 8V	
Commutator O.D.	32 (1.26)	31.4 (1.24)
Peripheral runout of commutator		Less than 0.03 (0.0012) <Up to 1995 models> Less than 0.05 (0.0020) <From 1996 models>
Inter-segment mica depth		Less than 0.2 (0.008)
Brush length	18 (0.71)	11 (0.43)
Brush spring tension	30 – 39 N (3 – 3.9 kgf, 6.8 – 8.8 lbs.)	20 N (2 kgf, 4.5 lbs.)

TORQUE SPECIFICATIONS

		Nm	Torque kgm	ft.lbs.
Starter motor mounting bolt	<Except 4M40 engine>	31	3.1	23
	<4M40 engine>	49	5.0	36

NOTES

2. STARTER MOTOR

REMOVAL AND INSTALLATION

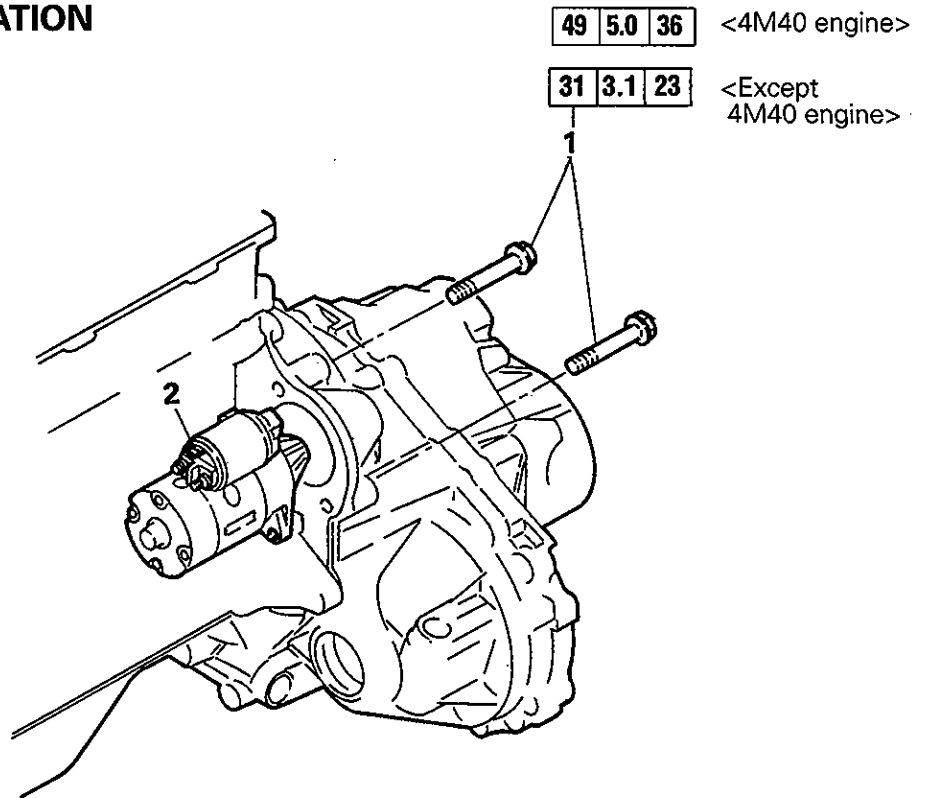

Removal steps

1. Bolt
2. Starter

1EL097

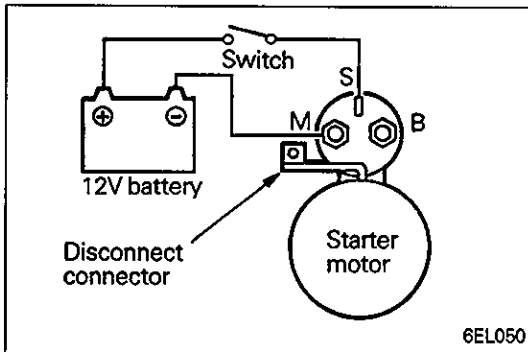

6EL050

INSPECTION

PINION GAP ADJUSTMENT (Direct Drive Type and Planetary Gear Reduction Drive Type)

- (1) Disconnect the field coil wire from terminal M of the magnetic switch.
- (2) Connect a 12V battery between terminal-S and terminal-M.
- (3) Set switch to "ON", and pinion will move out.

Caution

- **This test must be performed quickly (in less than 10 seconds) to prevent the coil from burning out.**

- (4) Measure the clearance between the pinion and stop ring (pinion gap). If there is some axial play, push the pinion lightly toward the armature during measurement.

Standard value: 0.5 – 2.0 mm (0.02 – 0.08 in.)

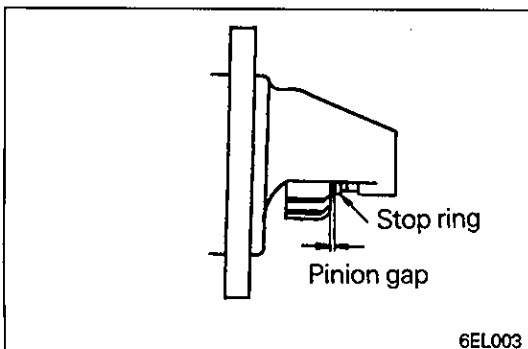

6EL003

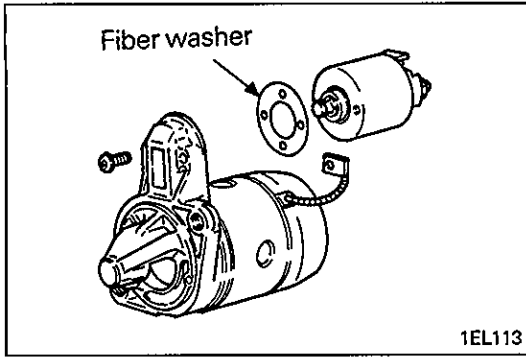

- (5) If the pinion gap is not up to specification, adjust by adding or removing fiber washers between the magnetic switch and the front bracket. Using more washers makes the gap smaller.

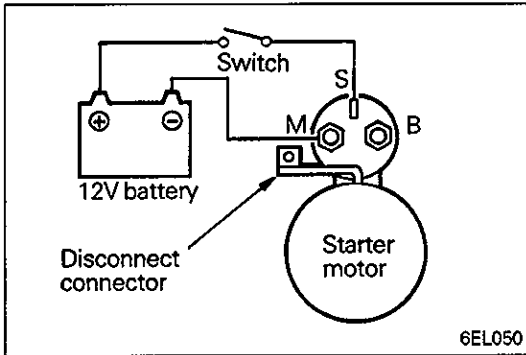

PINION GAP ADJUSTMENT (Spur Gear Reduction Drive Type)

- (1) Disconnect the field coil wire from terminal-M of the magnetic switch.
- (2) Connect a 12V battery between terminal-S and terminal-M.
- (3) Set the switch to "ON", and pinion will move out.

Caution

- This test must be performed quickly (in less than 10 seconds) to prevent coil from burning out.

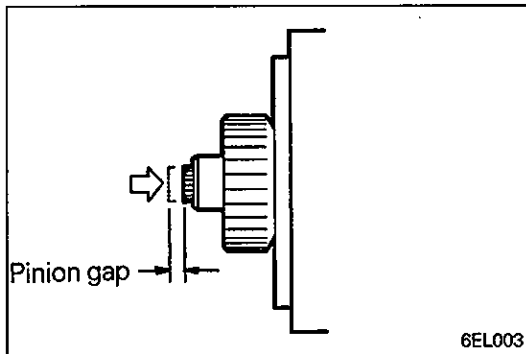

- (4) Push the pinion back with a finger and measure the pinion stroke (the travel along which the pinion is pushed back). This is the pinion gap.
- (5) If the pinion gap is not up to specification, adjust by adding or removing fiber washers between the magnetic switch and the front bracket. Using more washers makes the gap smaller.

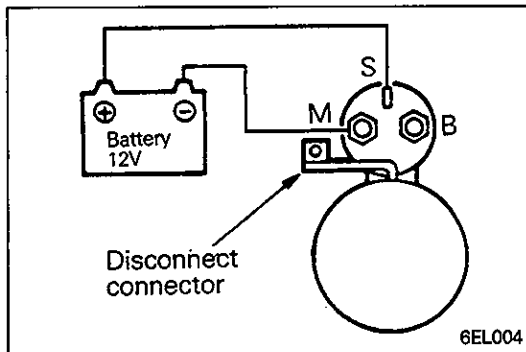

PULL-IN TEST OF MAGNETIC SWITCH

- (1) The pull-in coil is in good condition if the plunger is pulled in to cause the pinion to move out when a battery is connected between terminals S and M of the magnetic switch. If the pinion does not move out, replace the magnetic switch.

Caution

- The connector must be disconnected from terminal M for this test. The test must be finished within 10 seconds.

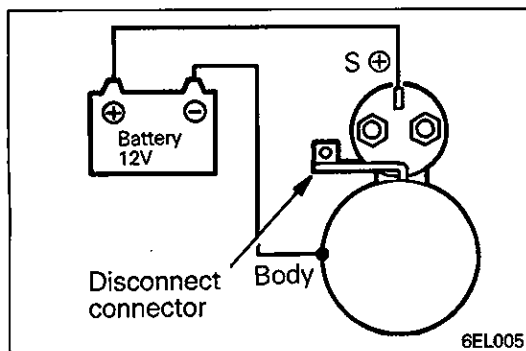

HOLD-IN TEST OF MAGNETIC SWITCH

- (1) With a battery connected between terminal S and the body of the magnetic switch, manually pull the pinion up to the pinion stopper. The hold-in coil is in good condition if the pinion remains out when releasing it.

Caution

- This test must be completed within 10 seconds.

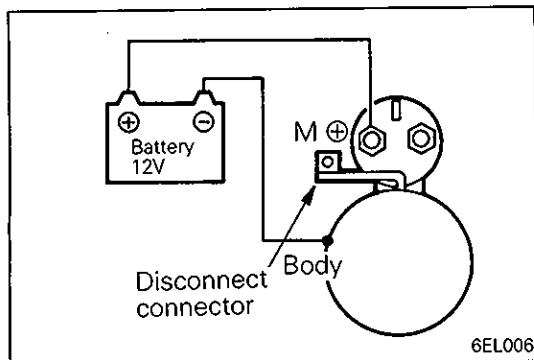
**RETURN TEST OF MAGNETIC SWITCH**

- (2) With a battery connected between terminal M and the body of the magnetic switch, manually pull the pinion out to the pinion stopper. Both coils are fully operational if the pinion returns immediately after releasing it.

Caution

- This test must be completed within 10 seconds.

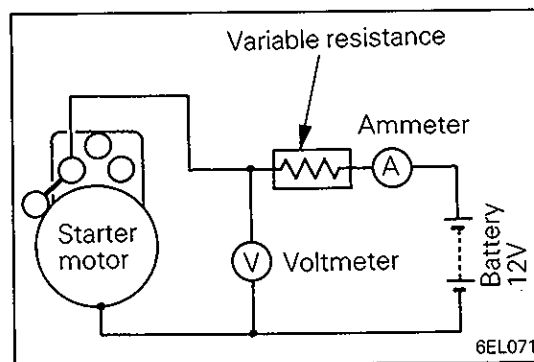
**NO-LOAD TEST**

- (1) Set up a circuit as shown which connects a starter motor, battery, ammeter, voltmeter, and variable resistance.
- (2) The starter motor should be in good condition if it turns smoothly and steadily when the switch is turned ON with a maximum variable resistance value.

NOTES

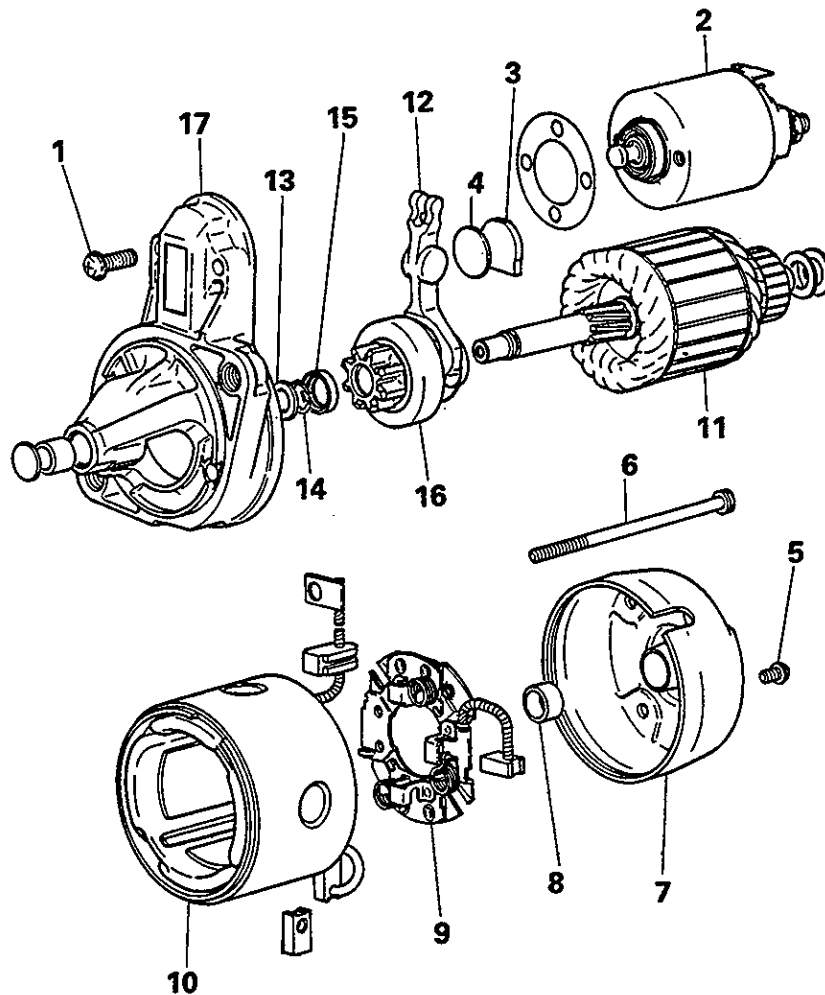
3. STARTER MOTOR <EXCEPT 4M40 ENGINE>**DISASSEMBLY AND REASSEMBLY – DIRECT DRIVE TYPE****Disassembly steps**

1. Screw
2. Magnetic switch
3. Packing
4. Plate
5. Screw
6. Through bolt
7. Rear bracket
8. Rear bearing
9. Brush holder
10. Yoke assembly
11. Armature
12. Lever
13. Washer
14. Snap ring
15. Stop ring
16. Overrunning clutch
17. Front bracket

DISASSEMBLY AND REASSEMBLY – SPUR GEAR REDUCTION DRIVE TYPE

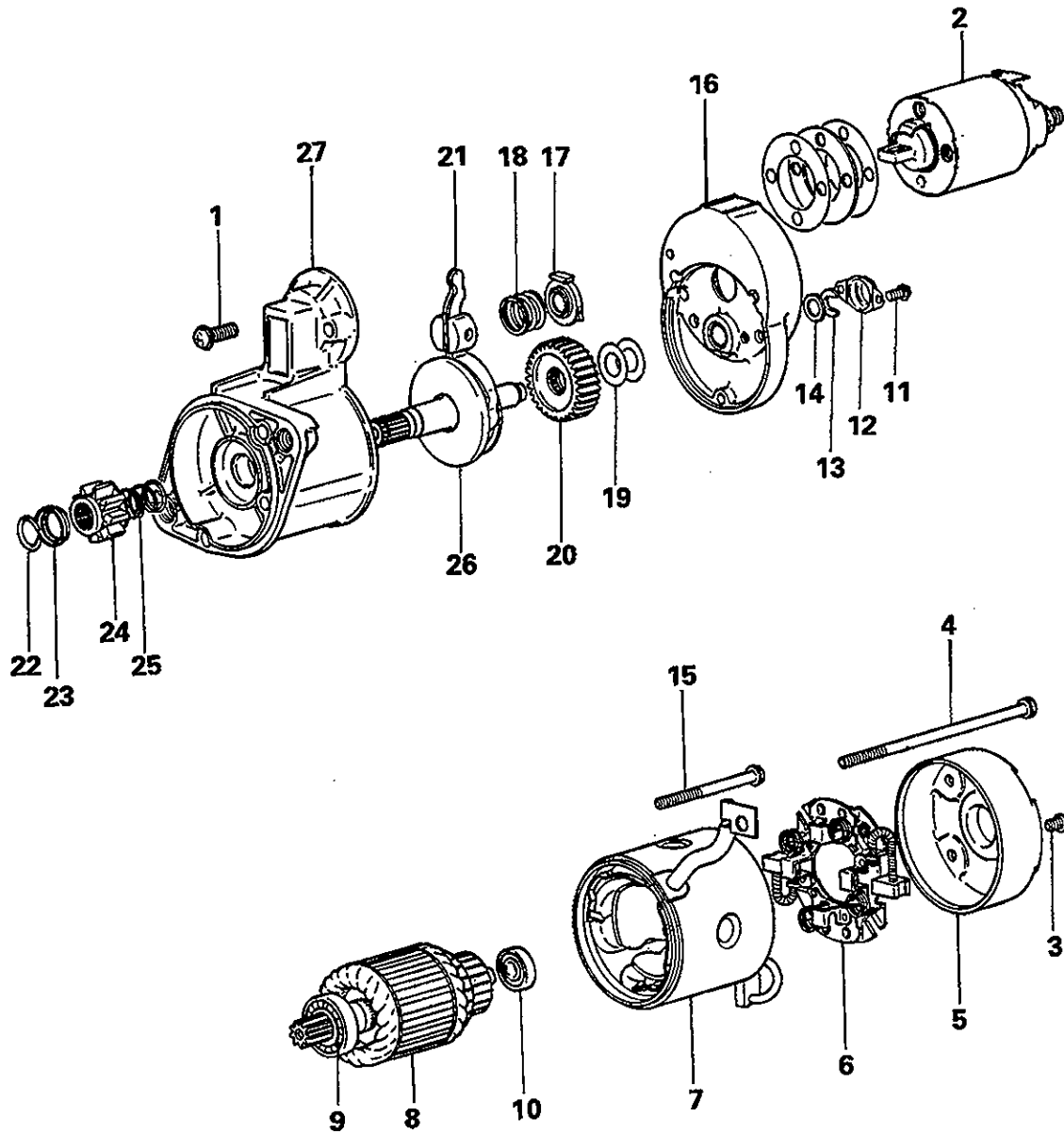

Disassembly steps

- | | | | |
|-----|--------------------|---------|---------------------------|
| | 1. Screw | | 14. Washer |
| ◊A◊ | 2. Magnetic switch | | 15. Screw |
| | 3. Screw | | 16. Center bracket |
| | 4. Screw | | 17. Spring seat |
| | 5. Rear bracket | | 18. Lever spring |
| | 6. Brush holder | | 19. Adjusting washer |
| | 7. Yoke assembly | | 20. Gear |
| | 8. Armature | | 21. Lever |
| | 9. Front bearing | ◊D◊ ◊A◊ | 22. Snap ring |
| | 10. Rear bearing | ◊D◊ ◊A◊ | 23. Stop ring |
| | 11. Screw | | 24. Pinion gear |
| | 12. Cover | | 25. Spring |
| ◊C◊ | 13. Snap ring | | 26. Pinion shaft assembly |
| | | | 27. Front bracket |

DISASSEMBLY AND REASSEMBLY – PLANETARY GEAR REDUCTION DRIVE TYPE <FOR PETROL ENGINE>

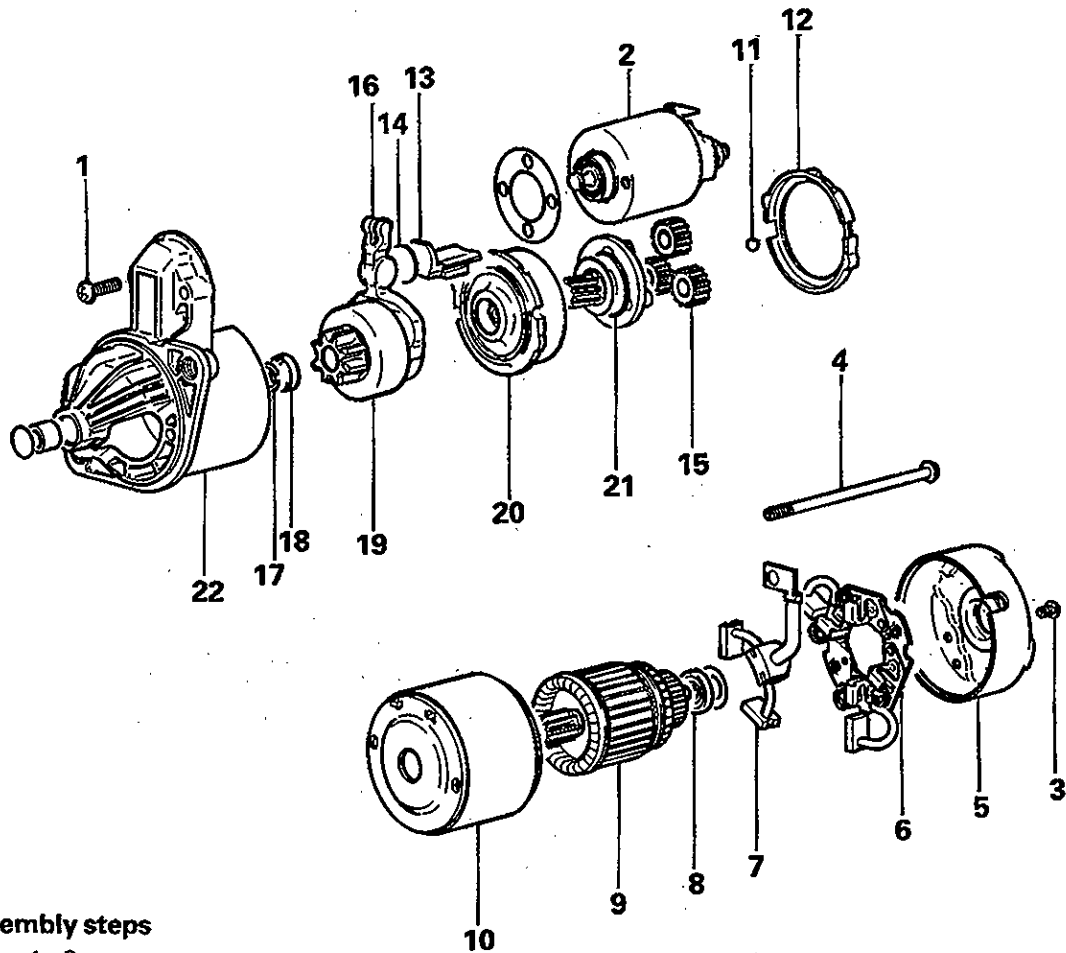

Disassembly steps

- 1. Screw
- ◊A◊ 2. Magnetic switch
- 3. Screw
- 4. Screw
- 5. Rear bracket
- 6. Brush holder
- 7. Brush
- 8. Rear bearing
- ◊B◊ 9. Armature
- ◊B◊ 10. Yoke assembly
- 11. Ball
- 12. Packing A
- 13. Packing B
- 14. Plate
- 15. Planetary gear
- 16. Lever
- ◊D◊ ◊A◊ 17. Snap ring
- ◊D◊ ◊A◊ 18. Stop ring
- 19. Overrunning clutch
- 20. Internal gear
- 21. Planetary gear holder
- 22. Front bracket

DISASSEMBLY AND REASSEMBLY – PLANETARY GEAR REDUCTION DRIVE TYPE
<FOR DIESEL ENGINE>

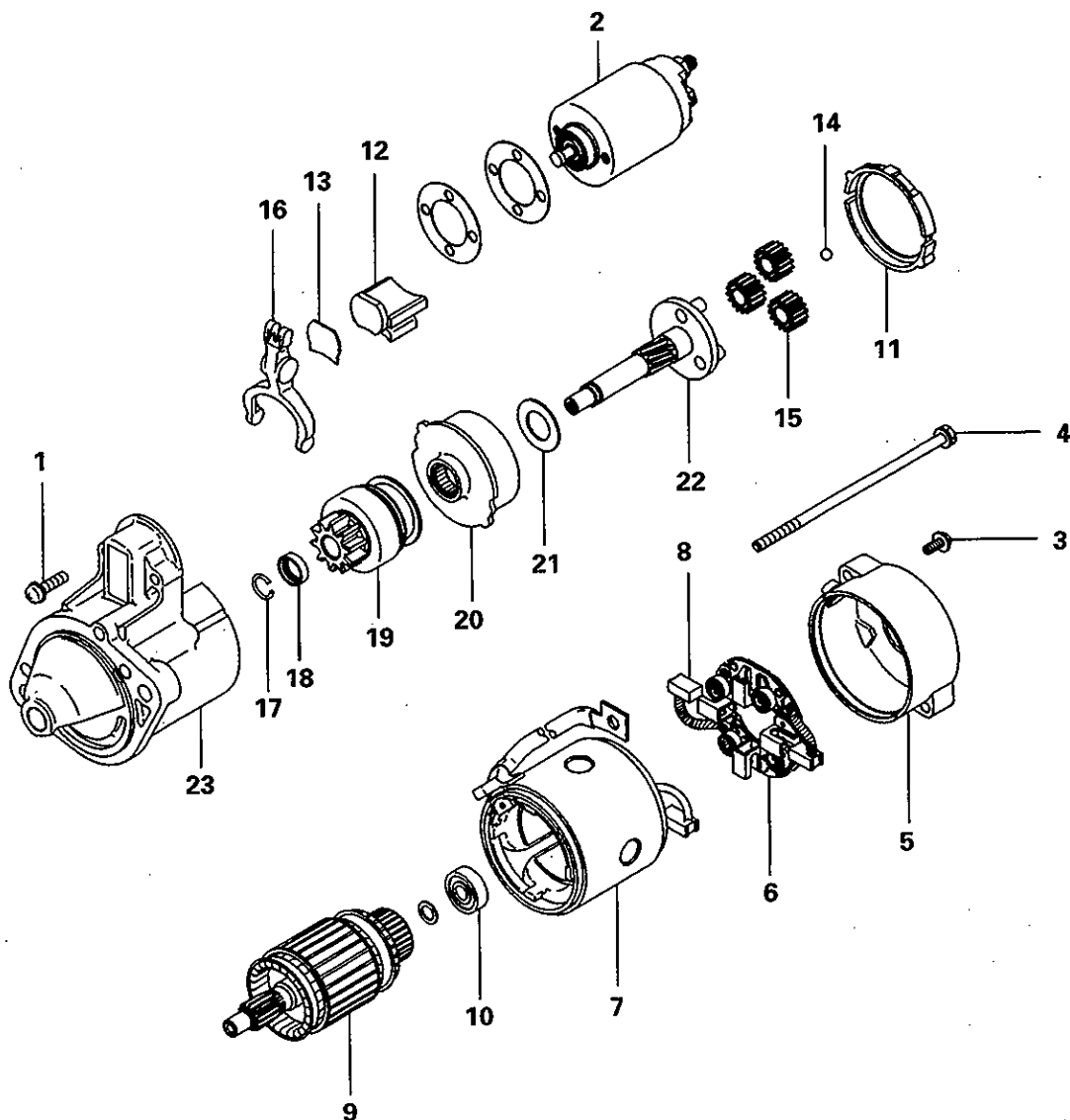

DEN0169

Disassembly steps

- 1. Screw
- ◁A▷ 2. Magnetic switch
- 3. Screw
- 4. Screw
- 5. Rear bracket
- 6. Brush holder
- 7. Yoke assembly
- 8. Brush
- ◁B▷ 9. Armature
- 10. Bearing
- 11. Packing A
- 12. Packing B

- 13. Plate
- ◁B▷ 14. Ball
- 15. Planetary gear
- 16. Lever
- ◁D▷ ▷A◁ 17. Snap ring
- ◁D▷ ▷A◁ 18. Stop ring
- 19. Overrunning clutch
- 20. Internal gear
- 21. Washer
- 22. Planetary gear holder
- 23. Front bracket

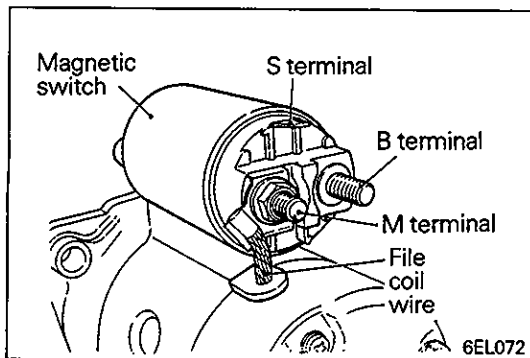

SERVICE POINTS OF DISASSEMBLY

◊A◊ REMOVAL OF MAGNETIC SWITCH

- (1) Disconnect the field coil wire from terminal M of the magnetic switch.

◊B◊ REMOVAL OF ARMATURE AND BALL

- (1) When removing the armature, do not lose the ball placed at the end as a bearing.

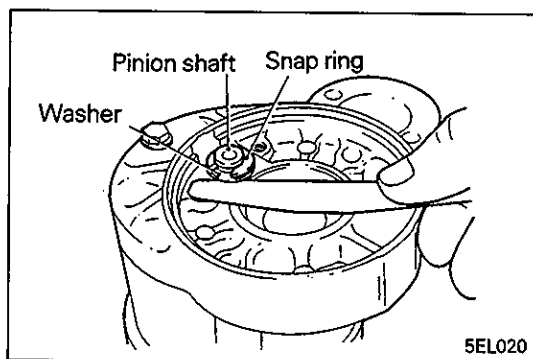

◊C◊ REMOVAL OF SNAP RING

- (1) Using a thickness gauge, measure the end play in the pinion shaft for the purpose of reassembly.

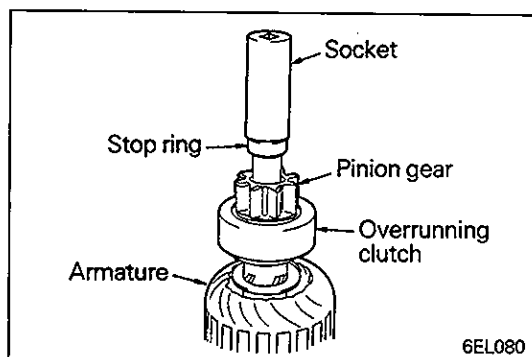

◊D◊ REMOVAL OF SNAP RING / STOP RING

- (1) Using an appropriate wrench socket, push the stop ring toward the overrunning clutch.

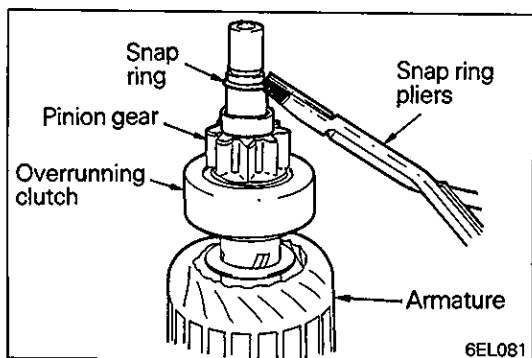

- (2) Remove the snap ring using snap ring pliers and then remove the stop ring and overrunning clutch.

CLEANING OF STARTER MOTOR PARTS

- (1) Do not immerse the parts in cleaning solvent. Immersion of the yoke, field coil assembly or armature in solvent will cause damage to the insulation.
- (2) Wipe clean with a cloth if these parts are dirty.
- (3) Do not immerse the drive unit in cleaning solvent. The overrunning clutch has been lubricated at the factory and cleaning with a solvent will remove the lubricant.
- (4) Clean the drive unit using a brush wetted with cleaning solvent and then wipe dry with a cloth.

INSPECTION**COMMUTATOR**

- (1) Place the armature on a pair of V-blocks and check the runout using a dial gauge.

Standard value: 0.05 mm (0.002 in.)
Limit: 0.1 mm (0.004 in.)

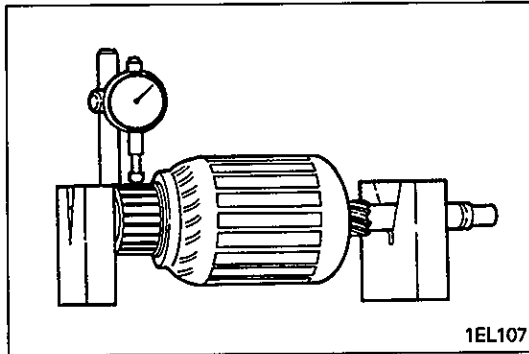

1EL107

- (2) Check the O.D. of the commutator.

**Direct drive type and spur gear reduction drive type,
planetary gear reduction drive type
(for diesel engine)**

Standard value: 32.0 mm (1.26 in.)
Limit: 31.0 mm (1.22 in.)

**Planetary gear reduction drive type
(for petrol engine)**

Standard value: 29.4 mm (1.16 in.)
Limit: 28.4 mm (1.12 in.)

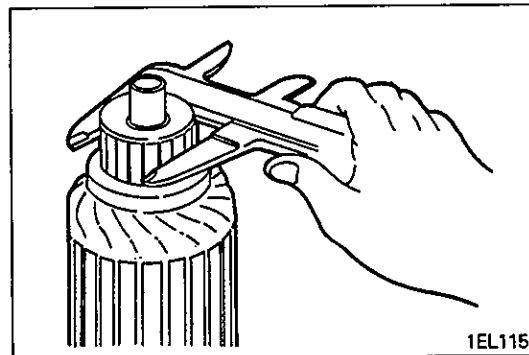

1EL115

- (3) Check depth of the undercuts between the segments.

Standard value: 0.5 mm (0.020 in.)
Limit: 0.2 mm (0.008 in.)

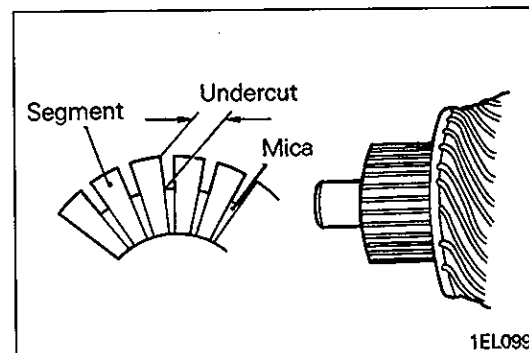

1EL099

FIELD COIL OPEN-CIRCUIT TEST – Except planetary gear reduction drive type (for petrol engine)

- (1) Check for continuity between the field brushes. There must be continuity.

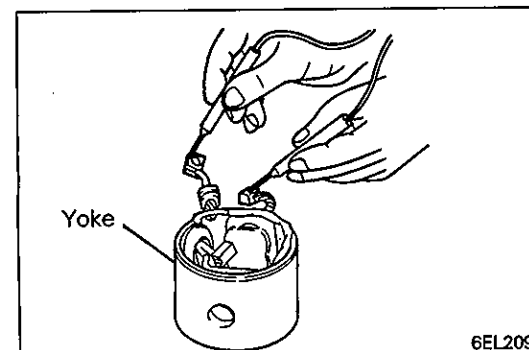

6EL209

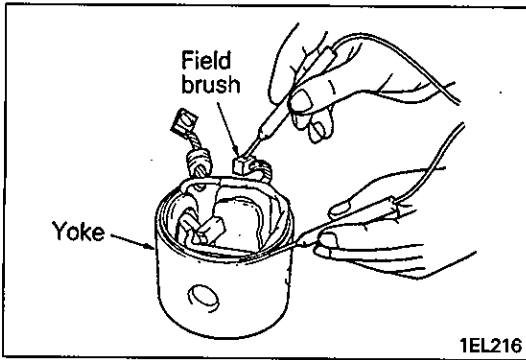

FIELD COIL GROUND TEST – Except planetary gear reduction drive type (for petrol engine)

- (1) Check for continuity between the field coil brush and yoke. There must be no continuity.

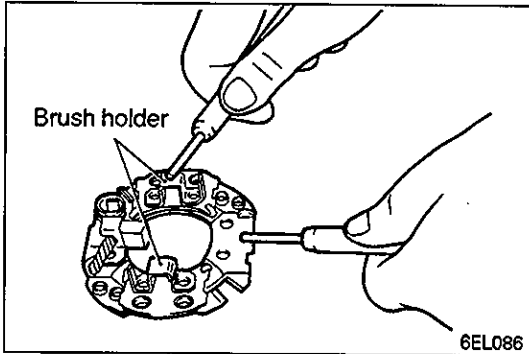

BRUSH HOLDER

- (1) Check continuity between the brush holder plate and the brush holder. The brush holder is okay if there is no continuity.

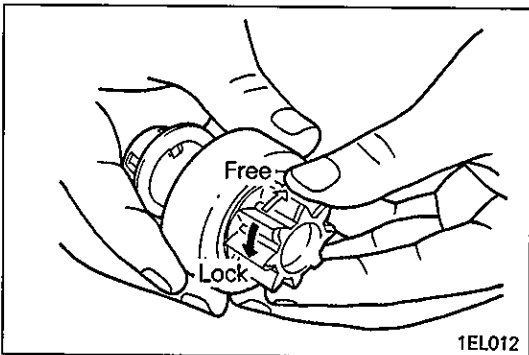

OVERRUNNING CLUTCH

- (1) Check that the pinion locks when it is turned counter-clockwise and moves smoothly when it is turned clockwise.
- (2) Check the pinion for wear or damage.

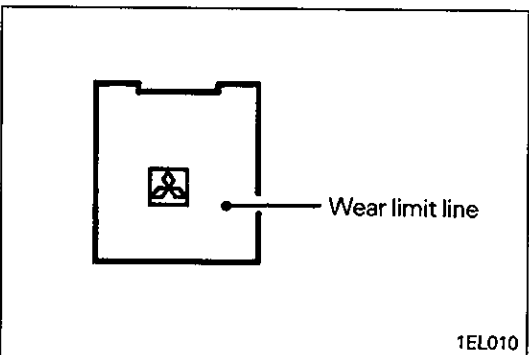

BRUSH

- (1) Check the brush for roughness of the surface that contacts the commutator and check the brush length.

Limit: Wear limit line

- (2) In case the contacting surface has been corrected or the brush has been replaced, correct the contacting surface by winding sandpaper around the commutator.

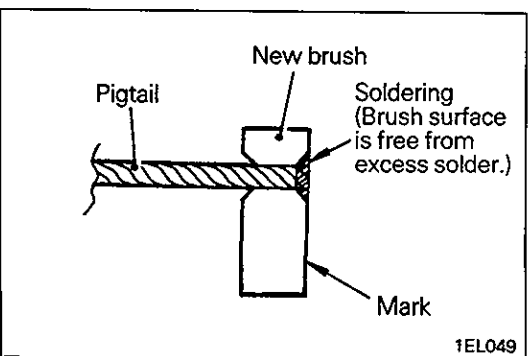

- (3) When removing a worn brush by breaking with pliers, use care to prevent damage to the pigtail.
- (4) Polish the pigtail end for secure soldering.
- (5) Insert the pigtail into the hole of a new brush and solder. Make sure that there is no excess solder on the brush surface.

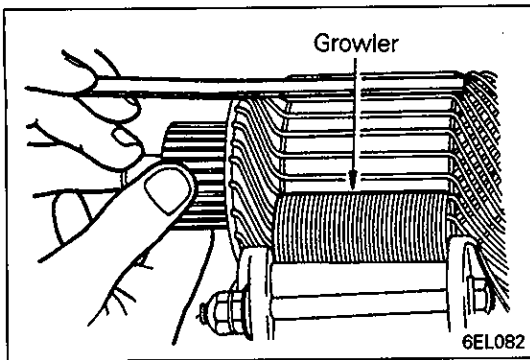

ARMATURE COIL SHORT CIRCUIT TEST

- (1) Set the armature on a growler.
- (2) While applying a thin piece of iron in parallel with the armature, turn the armature slowly. The armature is okay if the piece of iron is not attracted or does not vibrate.

Caution

- Clean the armature surface thoroughly before checking.

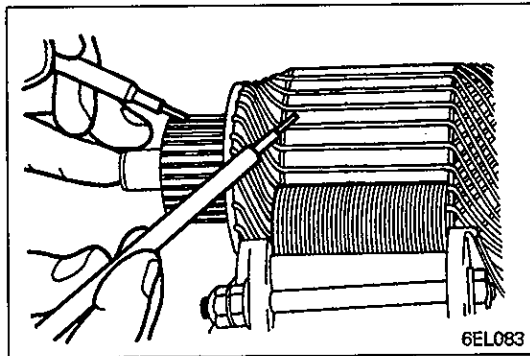

- (3) Check insulation between the commutator segments and the armature coil core. There should be no continuity.

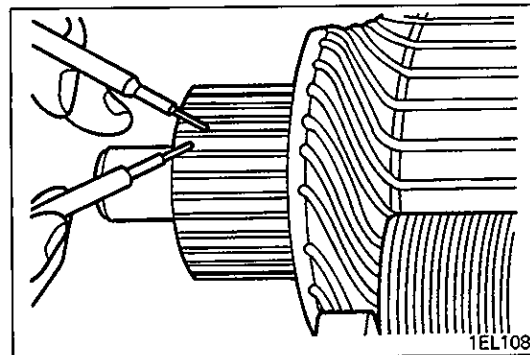

OPEN CIRCUIT CHECK OF ARMATURE

- (1) Check continuity between segments. There should be continuity.

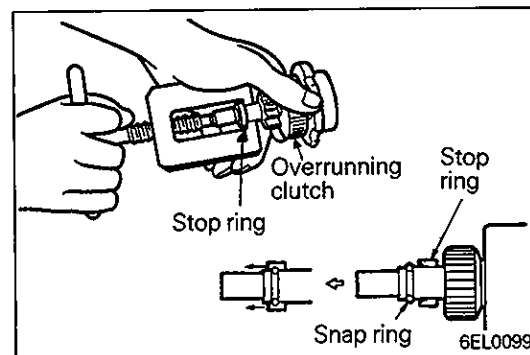

SERVICE POINTS OF REASSEMBLY

◆◆ INSTALLATION OF STOP RING / SNAP RING

- (1) Using an appropriate tool, pull the stop ring over the snap ring.

4. STARTER MOTOR <4M40 ENGINE>

DISASSEMBLY AND REASSEMBLY

<Up to 1995 models>

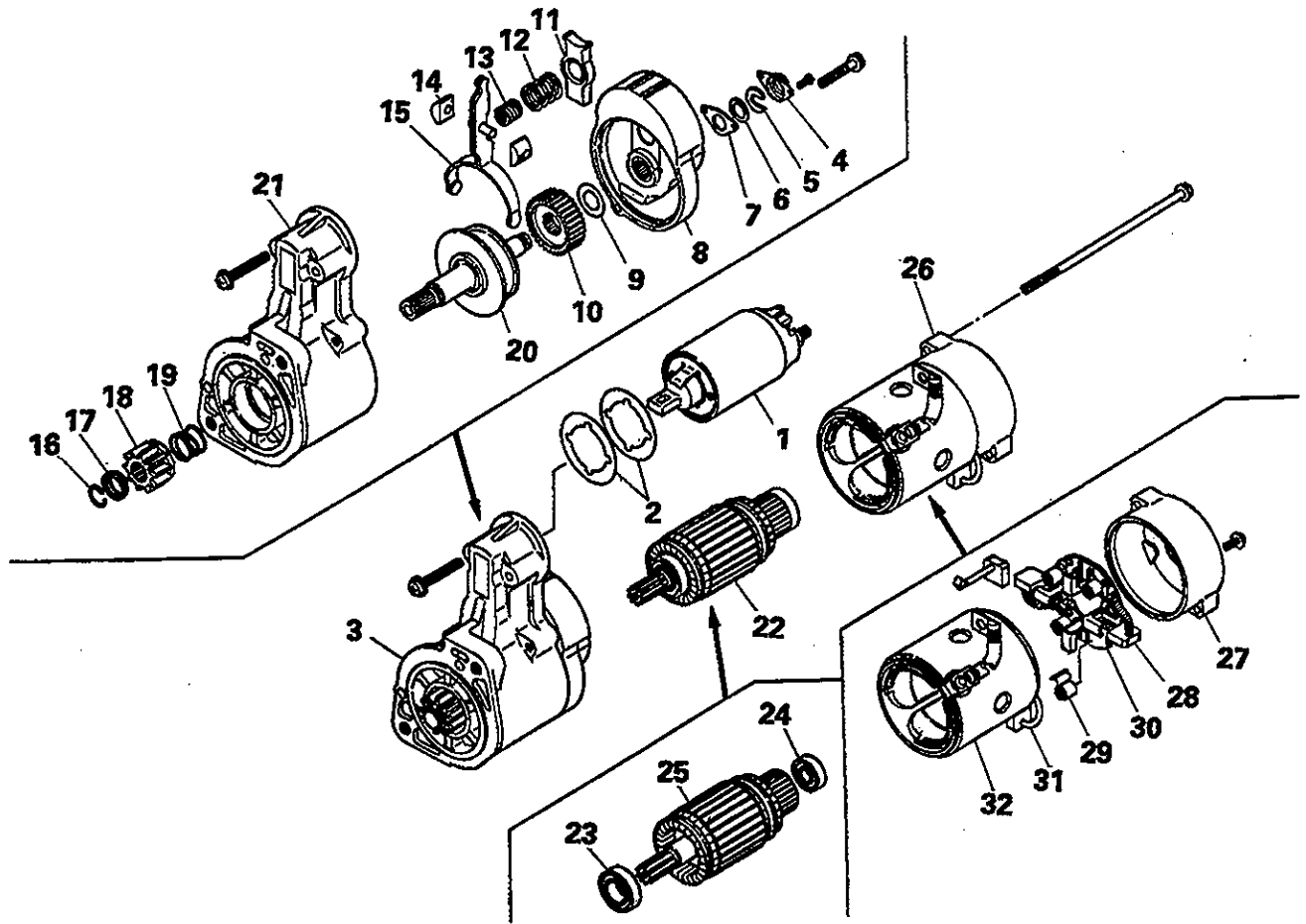

Disassembly steps

- ◆C◆ 1. Magnet switch
- 2. Shim
- 3. Front bracket assembly
- 4. Cover
- 5. Stopper
- 6. Washer
- 7. Plate
- 8. Center bracket
- 9. Adjusting washer
- 10. Gear
- 11. Packing
- 12. Outer spring
- 13. Inner spring
- 14. Bush
- ◆B◆ 15. Lever
- 16. Stopper ring

- 17. Pinion stopper
- ◆A◆◆A◆ 18. Pinion
- 19. Spring
- 20. Pinion shaft assembly
- 21. Front bracket
- 22. Armature
- 23. Front bearing
- 24. Rear bearing
- 25. Armature
- ◆B◆ 26. Yoke and rear bracket assembly
- 27. Rear bracket
- 28. Brush (-)
- 29. Brush spring
- 30. Brush holder assembly
- 31. Brush (+)
- 32. Yoke assembly

DISASSEMBLY AND REASSEMBLY

<From 1996 models>

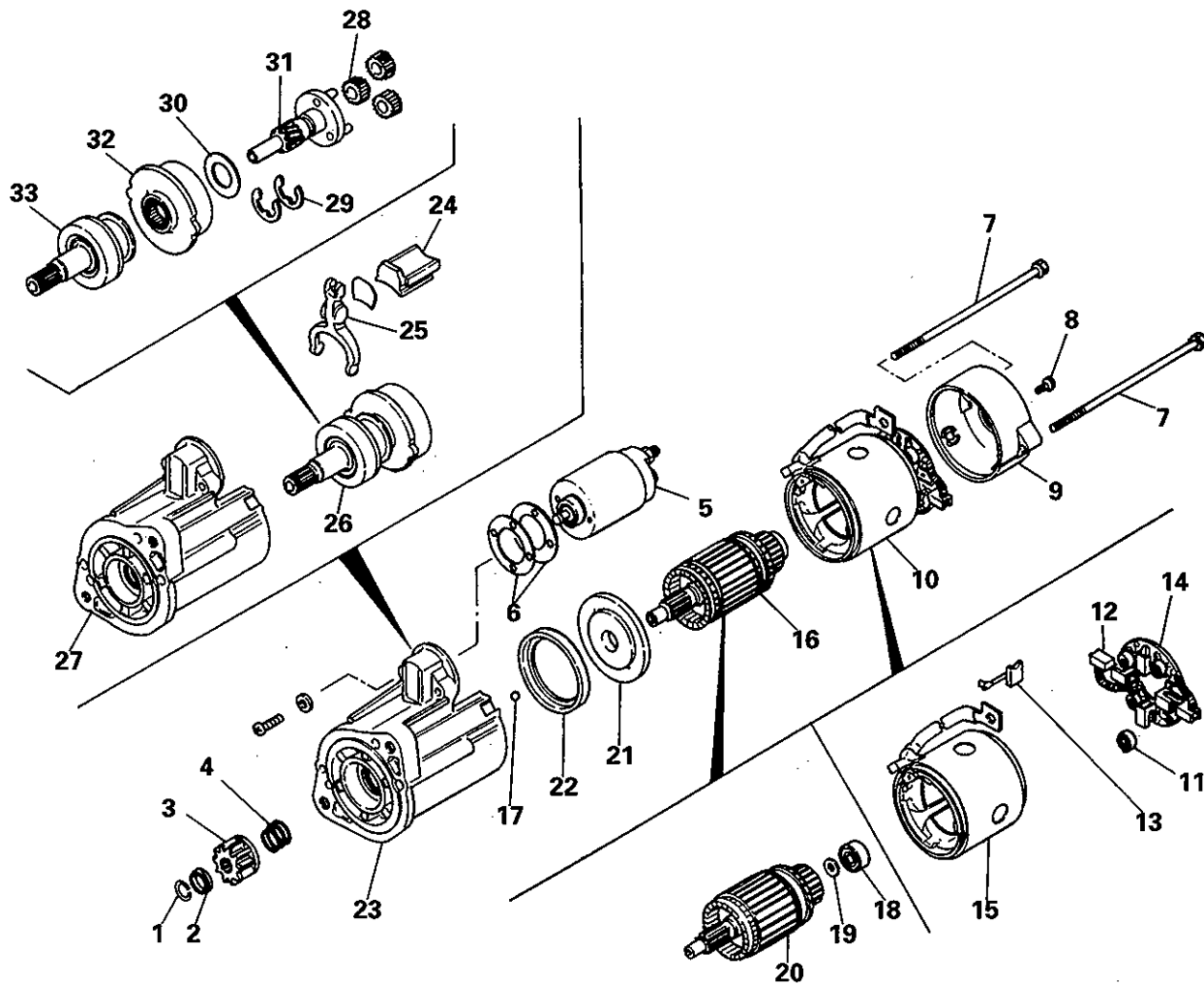

Disassembly steps

- | | | |
|---------|----------------------------------|--|
| | 1. Stopper ring | 18. Rear bearing |
| | 2. Pinion stopper | 19. Washer |
| ◀A▶ ▶A▶ | 3. Pinion | 20. Armature assembly |
| | 4. Spring | 21. Cover |
| ▶C▶ | 5. Magnet switch | 22. Rubber packing |
| | 6. Shim | 23. Front bracket |
| | 7. Bolt | 24. Rubber packing |
| | 8. Screw | ▶B▶ 25. Lever |
| | 9. Rear bracket | 26. Gear shaft & overrunning clutch assembly |
| ◀B▶ | 10. Yoke & brush holder assembly | 27. Front bracket |
| | 11. Brush spring | 28. Planetary gear |
| | 12. Brush (-) | 29. Washer |
| | 13. Brush (+) | 30. Washer |
| | 14. Brush holder assembly | 31. Gear shaft |
| | 15. Yoke assembly | 32. Internal gear |
| | 16. Armature assembly | 33. Overrunning clutch |
| | 17. Ball | |

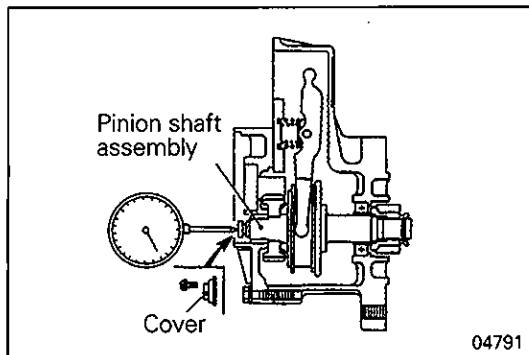

04791

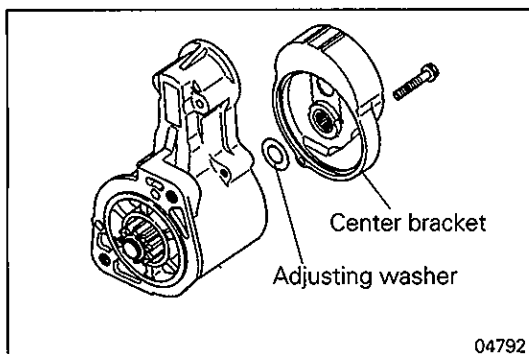

04792

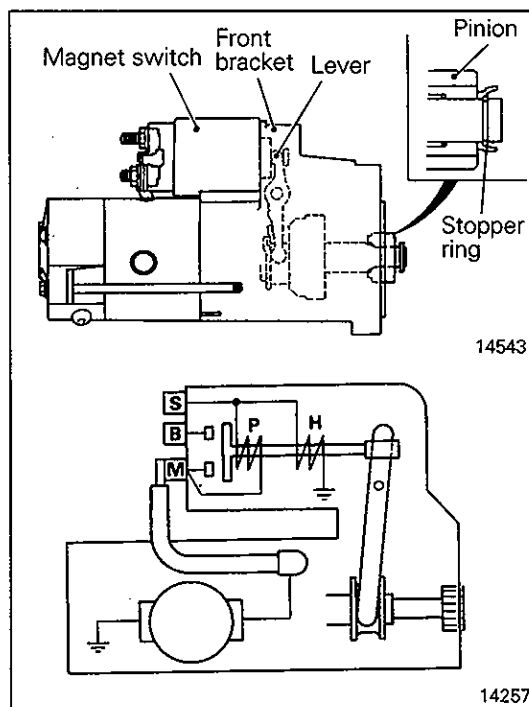

14543

14257

PRE-DISASSEMBLY INSPECTION**PINION SHAFT ASSEMBLY THRUST GAP**

<Up to 1995 models>

Checking

- (1) Remove the cover, and measure the thrust gap of the pinion shaft assembly. If the reading deviates from the specified standard value, make adjustment in the following manner.

Standard value: 0.1 mm – 0.5 mm (0.004 – 0.020 in.)**Adjustment**

- (1) Remove the center bracket and replace the existing adjusting washer with an appropriate adjusting washer with different thickness.

Available adjusting washers: 0.25 mm (0.0098 in.) and 0.5 mm (0.0197 in.) thick**DISASSEMBLY SERVICE POINTS****◇A◇ PINION DISASSEMBLY**

Remove the pinion with power supplied to the starter and the pinion in its popped-out position.

Caution

- When power is supplied to the starter, the pinion pops out and rotates. Keep your hands away from the pinion at this time.
- The magnet switch may be extremely hot after inspection. Be careful not to touch it.
- Do not supply power to the pull-in coil P for more than 10 seconds. Do not supply power to the holding coil H for more than 30 seconds. If these time limits are exceeded, the coil(s) may overheat and burn out.
- The pinion must be popped out electrically by supplying power to the starter. Do not pop out the pinion by pulling the lever since the front bracket and lever may be damaged when the stopper ring is removed.
- When the starter is energized, current of more than 100A flows. Thus, heavy-duty cables (as thick as booster cables) must be used to connect the starter for inspection, and all connections must be securely tightened.

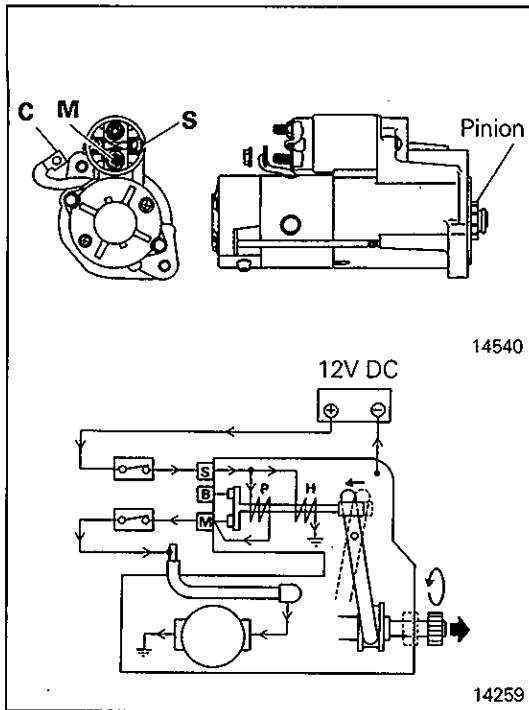

- (1) Connect the starter as shown in the illustration. Here,
 - A:** Switch,
 - B:** Switch,
 - C:** Cable,
 - M:** Starter M terminal,
 - S:** Starter S terminal.

NOTE

The following procedure must be carried out with power supplied to the starter. Thus, the pinion must be removed within 30 seconds of turning ON the power.

- (2) Supply power to the starter by turning ON switches **A** and **B**. The pinion will pop out and rotate.

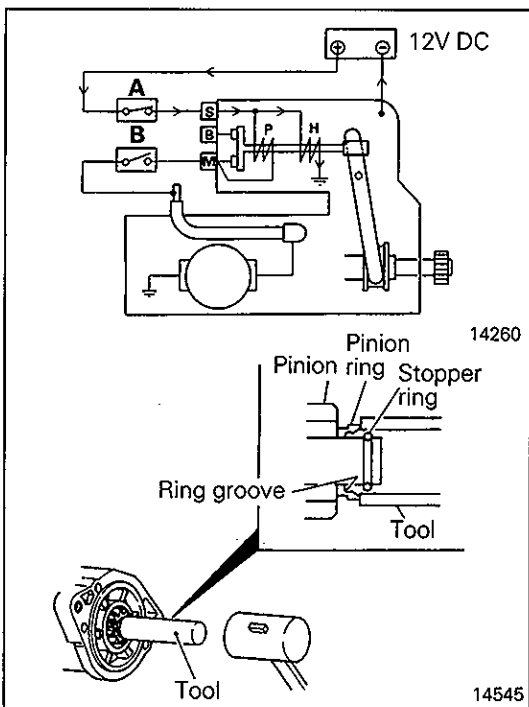

- (3) Within 5 seconds of the pinion's rotation, turn OFF switch **B** to stop the pinion from rotating.

Caution

- With switches **A** and **B** turned ON, power is supplied to both the pull-in coil **P** and holding coil **H**. No voltage is applied to starter terminal **B**, so current flows in the pull-in coil while the pinion is rotating. To prevent the pull-in coil from burning out, switch **B** must therefore be turned OFF within 5 seconds of the pinion's rotation.

- (4) Apply a suitable tubular tool to the pinion stopper.
- (5) Lightly tap the tubular tool with a hammer to remove the stopper ring from the pinion stopper ring groove.
- (6) Remove the stopper ring and pinion.
- (7) Turn OFF switch **A** to cut the supply of power to the starter.

Caution

- When the starter power is cut, the pinion may pop in, causing the stopper ring to go back into the ring groove. If this occurs, switch ON the starter power and repeat the procedure.

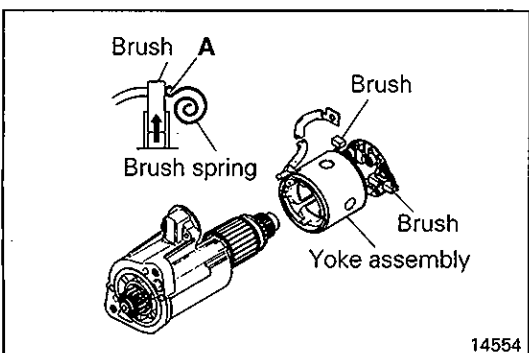

◁B▷ YOKE AND BRUSH HOLDER (REAR BRACKET) ASSEMBLY REMOVAL

- (1) Pull the brush spring at point **A** and raise the brush.
- (2) After raising the brush, hold it in place with the brush spring as shown in the illustration.
- (3) Remove the yoke assembly.

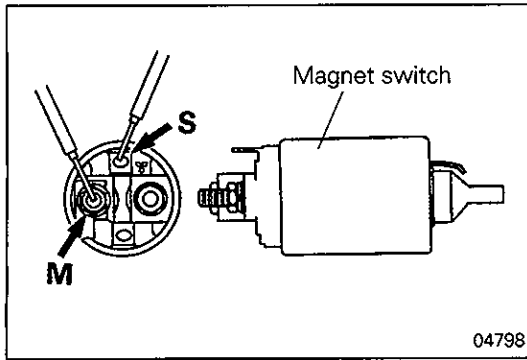
**INSPECTION****MAGNET SWITCH****Coil Open-Circuit Test**

- (1) Check for continuity between **S** and **M** terminals. If no continuity is detected, replace the magnet switch.

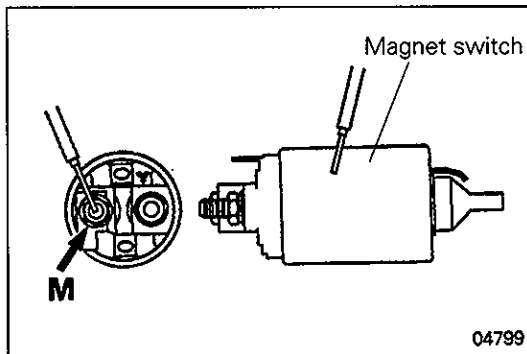

- (2) Check for continuity between **M** terminal and the body. If no continuity is detected, replace the magnet switch.

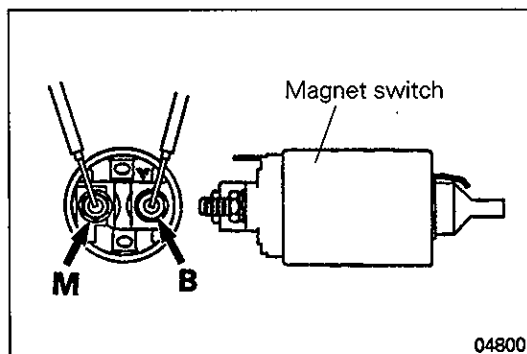
**Fused Contacts**

- (1) Check for continuity between **B** and **M** terminals. If continuity is detected, replace the magnet switch.

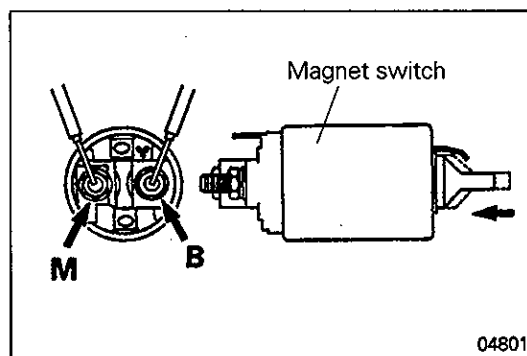
**Contact Test**

- (1) Push in the tip end of the magnet switch as shown to close its internal contacts.
- (2) In this state, check for continuity between **B** and **M** terminals. If no continuity is detected, replace the magnet switch.

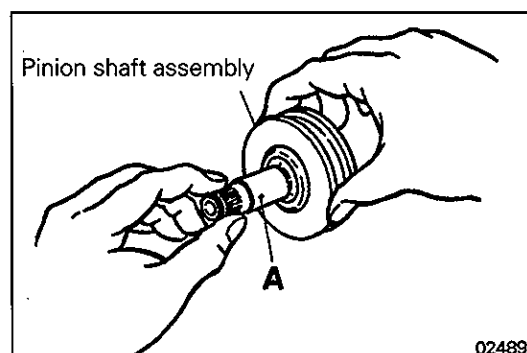
**PINION SHAFT ASSEMBLY**

- (1) Check that the shaft **A** of the pinion shaft assembly smoothly turns when given a clockwise turn (in activating direction) and that it is locked when a counterclockwise turn is attempted. Replace the pinion shaft assembly if it malfunctions.

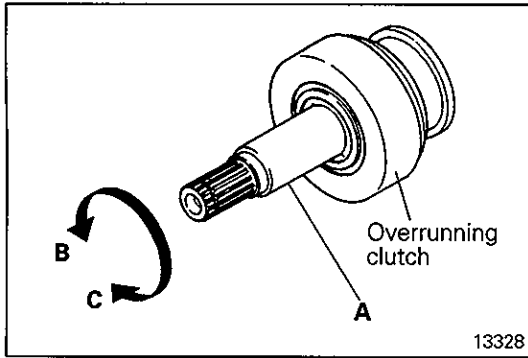

OVERRUNNING CLUTCH

Check the overrunning clutch as follows and replace it if necessary:

- (1) Rotate the shaft **A** in the **B** direction and check that it turns smoothly.
- (2) Rotate the shaft **A** in the **C** direction and check that it locks.

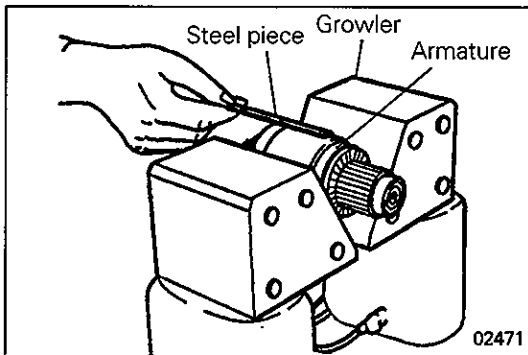

ARMATURE

Coil Short-Circuit Test

- (1) Place the armature in a growler, and hold a small thin piece of steel close to the armature in parallel.
- (2) Turn the armature slowly by hand. If the steel piece is attracted or vibrated, replace the armature because coil is short-circuited.

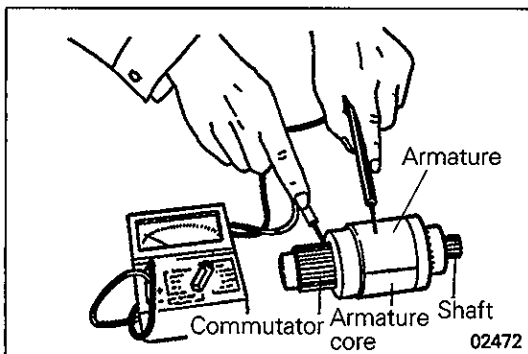

Coil Grounding Test

- (1) Check that there is no continuity between the commutator and armature core (or shaft). If continuity is detected, replace the armature because the coil is grounded.

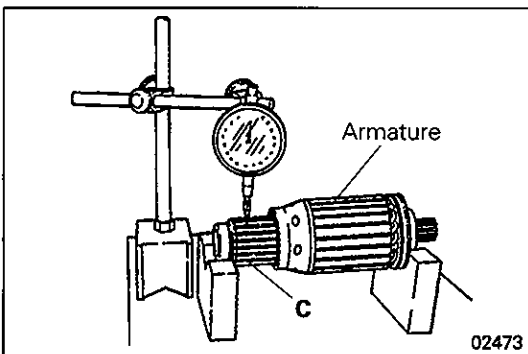

Commutator Runout

- (1) Turning the armature by hand, check the commutator **C** for runout.
- (2) If the reading exceeds the specified service limit, correct the commutator O.D. to within the limit.

Limit: 0.03 mm (0.0012 in.) <Up to 1995 models>
0.05 mm (0.0020 in.) <From 1996 models>

Commutator Surface Roughness

- (1) If the commutator surface is too rough or stepwise worn, redress it with sandpaper (#300 – 500). After redressing, be sure to check the commutator **C** for runout.

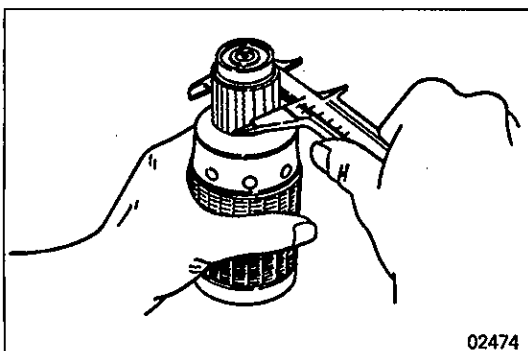

Commutator Outside Diameter

- (1) If the measurement exceeds the specified service limit, replace the armature.

Standard valve: 32 mm (1.26 in.)
Limit: 31.4 mm (1.24 in.)

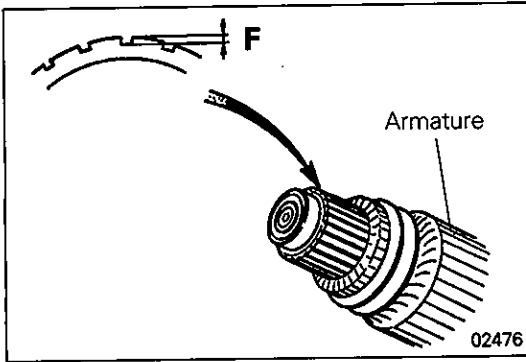

Segment Undercut Depth

- (1) Measure the undercut depth of mica between the commutator segments. If the measurement is less than the specified service limit, replace the armature.

F: Undercut depth of mica

Limit: 0.2 mm (0.008 in.)

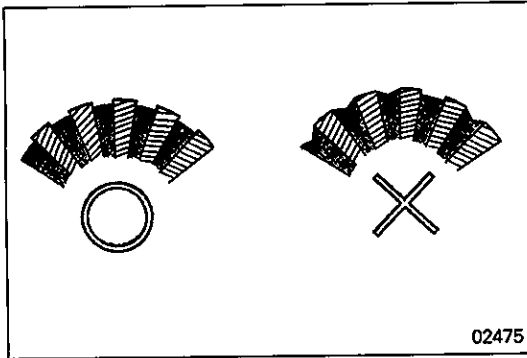

- (2) If the commutator segments are in such a condition as shown, replace the armature.

O: Good

X: No good

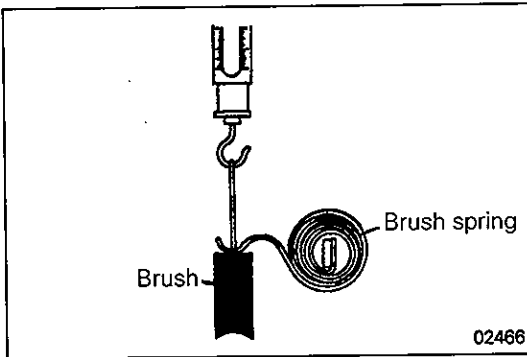

BRUSH SPRING

- (1) Using a new brush, measure the load at the moment the brush spring leaves the brush as shown. If the reading exceeds the specified service limit, replace the brush spring.

Standard value: 30 – 39 N (3 – 3.9 kgf, 6.6 – 8.8 lbs.)

Limit: 20 N (2 kgf, 4.5 lbs.)

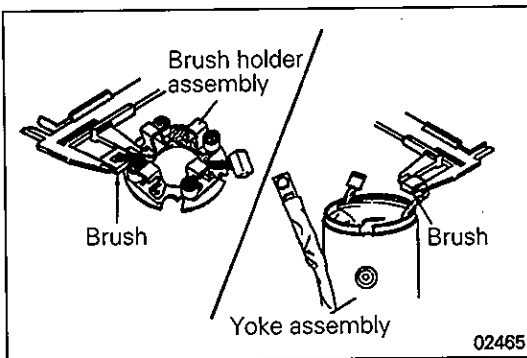

BRUSH

Brush Length

- (1) Measure the length of the two brushes. If the reading exceeds the specified service limit, replace the yoke assembly in the case of the (+) brush and the brush holder assembly in the case of the (-) brush.

Standard value: 18 mm (0.71 in.)

Limit: 11 mm (0.43 in.)

Commutator Contact Surface

- (1) If the contact surface is too rough or unevenly worn, redress it with sandpaper (#300 – 500).

Caution

- **Finish the contact surface to the same curvature as the commutator.**

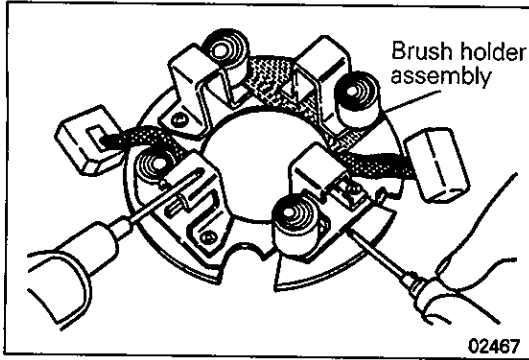
**BRUSH HOLDER ASSEMBLY**

- (1) Check that there is no continuity between the (+) side brush holder and the (-) side holder plate. If continuity is detected, replace the brush holder assembly because it is grounded.

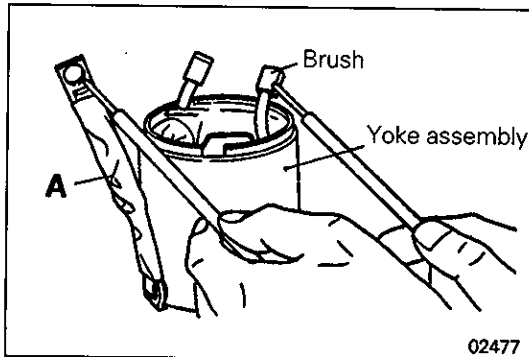
**YOKE ASSEMBLY****Coil Open-Circuit Test**

- (1) Check that there is continuity between the cable **A** and the brush. If no continuity is detected, replace the yoke assembly because coil is open.

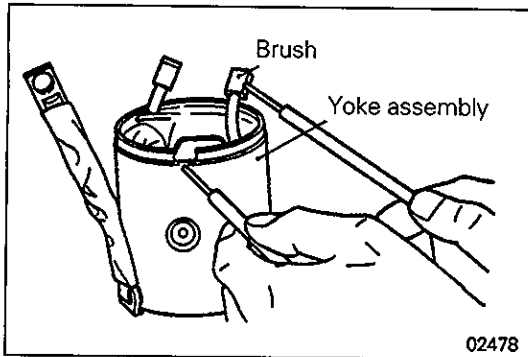
**Coil Grounding Test**

- (1) Check that there is no continuity between the yoke assembly and the brush. If continuity is detected, coil is grounded. Check insulation and repair. Replace the yoke assembly if necessary.

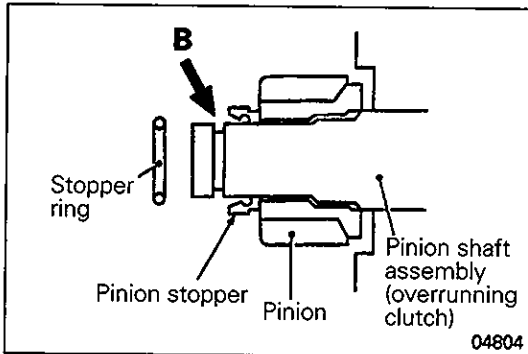
**REASSEMBLY SERVICE POINTS****◆A◆ PINION INSTALLATION**

- (1) Install the pinion and the pinion stopper in the direction shown in the illustration.
- (2) Install the stopper ring in the ring groove **B** of the pinion shaft assembly (overrunning clutch).

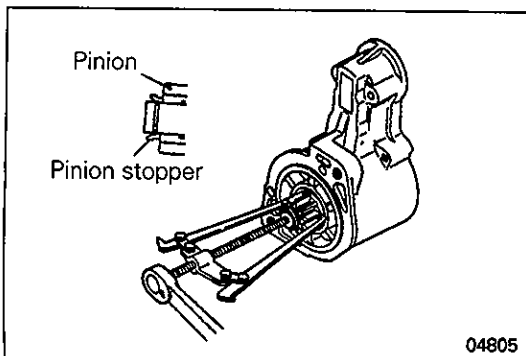

- (3) Pulling the pinion hard, secure the pinion stopper to the stopper ring.

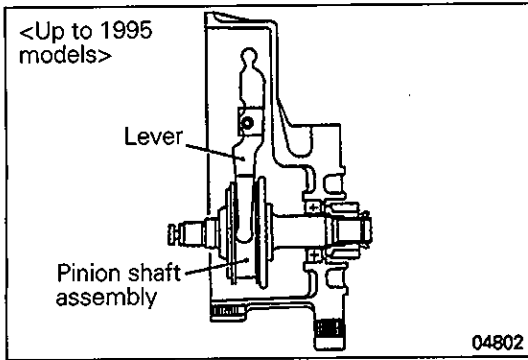

▶B▶ LEVER INSTALLATION

- (1) Install the lever to the pinion shaft assembly (overrunning clutch) in the direction shown in the illustration.

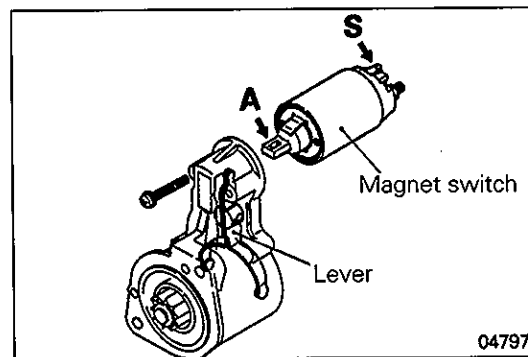
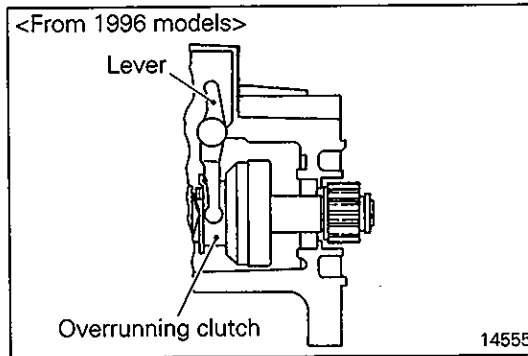

▶C▶ MAGNET SWITCH INSTALLATION

<Up to 1995 models>

- (1) Grease the magnet switch at **A** shown and install it to the lever with **S** terminal upward.

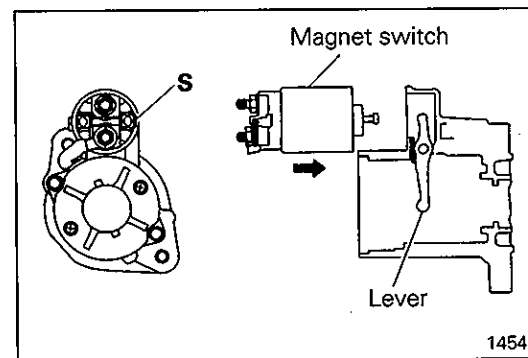

<From 1996 models>

- (1) Fit the magnet switch onto the lever with its **S** terminal positioned as shown in the illustration.

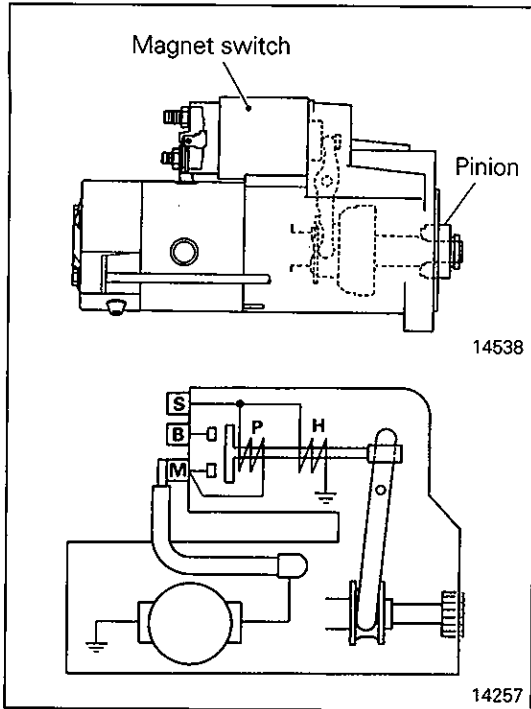

POST-ASSEMBLY INSPECTION

After assembly, the starter must be inspected with the power applied.

Caution

- When power is supplied to the starter, the pinion pops out and rotates. Keep your hands away from the pinion at this time.
- The magnet switch may be extremely hot after inspection. Be careful not to touch it.
- Do not supply power to the pull-in coil P for more than 10 seconds. Do not supply power to the holding coil H for more than 30 seconds. If these time limits are exceeded, the coil(s) may overheat and burn out.
- When the starter is energized, current of more than 100A flows. Thus, heavy-duty cables (as thick as booster cables) must be used to connect the starter for inspection, and all connections must be securely tightened.

PERFORMANCE TEST

(1) Connect the starter as shown in the illustration. Here,

- A:** Ammeter,
B: Starter B terminal,
C: Switch,
D: Battery (DC power supply),
S: Starter S terminal,
V: Voltmeter.

(2) Set the voltage to 11V DC.

Caution

- The voltage applied must not exceed 12V DC.

NOTE

The following procedure must be carried out with power supplied to the starter. Thus, starter current and speed measurement must be completed within 30 seconds of turning ON the power.

(3) Supply power to the starter by turning ON the switch. The pinion will pop out and rotate.

Caution

- With the switch turned ON, power is supplied to both the pull-in coil P and holding coil H. When large current flows from terminal B to terminal M, the supply of current to the pull-in coil is cut, so only the holding coil is energized. To prevent the holding coil from burning out, this procedure must therefore be completed within 30 seconds.

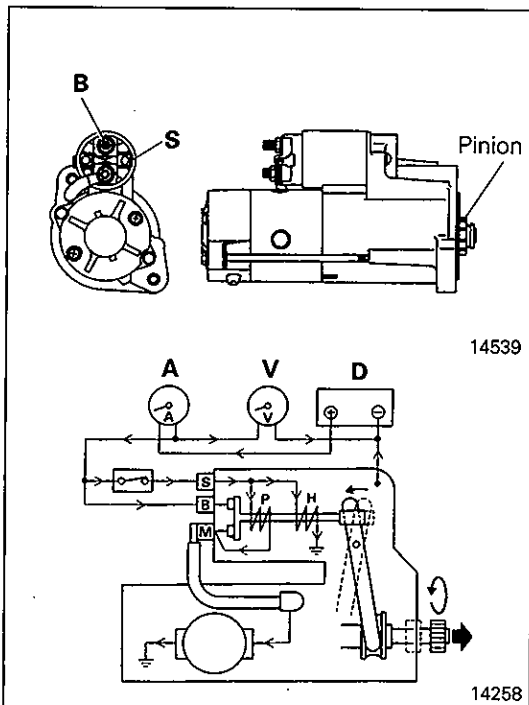

- (4) Measure the current and starter speed. Measure the starter speed using a stroboscope on the pinion.

Standard values:

<Up to 1995 models>

Current: 130A or less

Speed: 4,500 r/min. or less

<From 1996 models>

Current: 130A or less

Speed: 3,800 r/min. or less

- (5) Turn OFF the switch to cut the power to the starter.
 (6) If the measurements are out of specification, disassemble the starter and inspect it again.

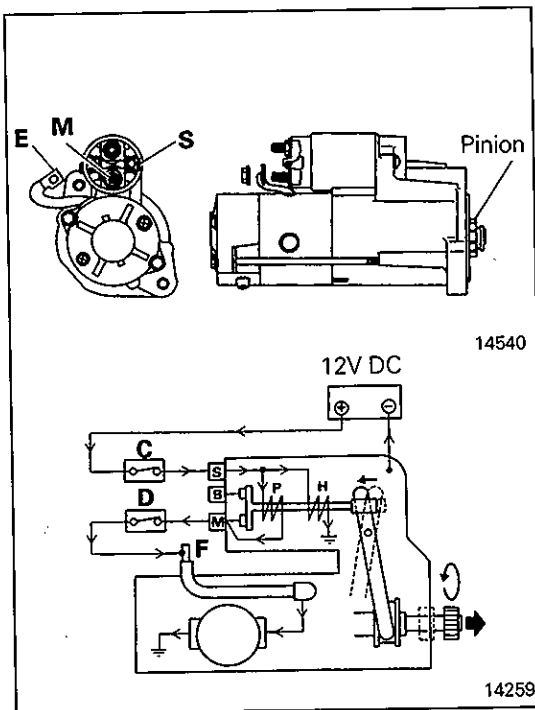

PINION GAP Inspection

- (1) Connect the starter as shown in the illustration. Here,
C: Switch,
D: Switch,
E: Cable,
M: Starter M terminal,
S: Starter S terminal.

NOTE

The following procedure must be carried out with power supplied to the starter. Thus, pinion gap measurement must be completed within 30 seconds of turning ON the power.

- (2) Turn ON switches **C** and **D** to supply power to the starter. The pinion will pop out and rotate.

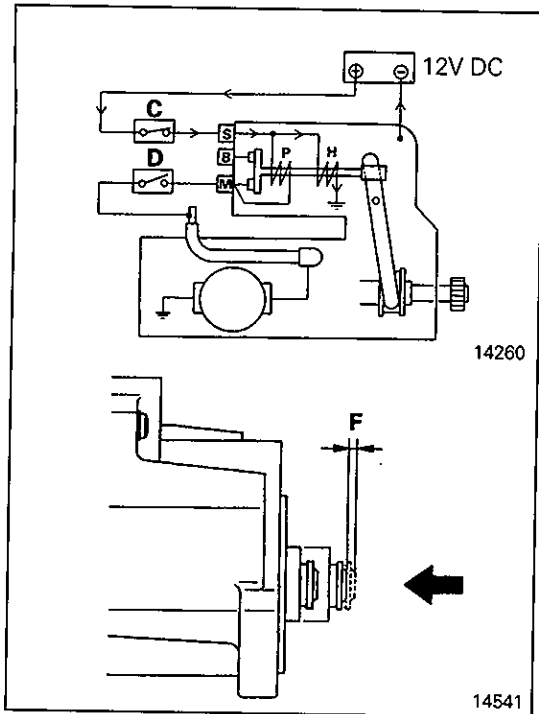

- (3) Within 5 seconds of the pinion's rotation, turn OFF switch **D** to stop the pinion from rotating.

Caution

- With switches **C** and **D** turned **ON**, power is supplied to both the pull-in coil **P** and holding coil **H**. No voltage is applied to terminal **B** of the starter, so current flows in the pull-in coil while the pinion is rotating. To prevent the pull-in coil from burning out, switch **D** must therefore be turned **OFF** within 5 seconds of the pinion's rotation.
- (4) Lightly depress the end of the overrunning clutch and measure the extent of axial movement **F**.
- Standard value: 0.5 – 2.0 mm (0.020 – 0.079 in.)**
- (5) Turn OFF switch **C** to cut the supply of power to the starter.

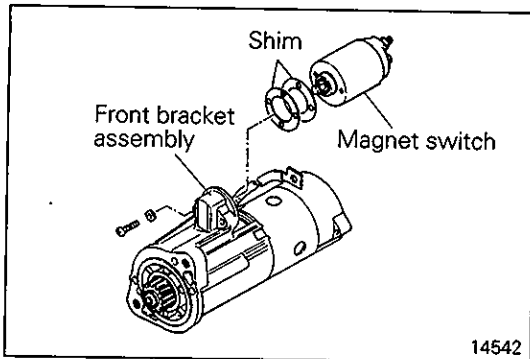

Adjustment

- (1) Remove the magnet switch from the front bracket assembly.
- (2) Adjust the gap by altering the overall shim thickness. Increasing the number of shims causes the gap to decrease.

Shim types: 0.25 mm, 0.5 mm