ENGINE AND EMISSION CONTROL

ENGINE AND EMISSION CONTROL

CONTENTS

1710900094

ENGINE CONTROL SYSTEM	3	Vacuum Circuit Diagram	8
GENERAL INFORMATION	3	Vacuum Hose Check	9
SERVICE SPECIFICATIONS	3	Vacuum Hose Installation	9
SEALANT	3	CRANKCASE EMISSION CONTROL	
ON-VEHICLE SERVICE	3	SYSTEM	9
Accelerator Cable Check and Adjustment ...	3	General Information	9
ACCELERATOR CABLE AND PEDAL	4	System Diagram	9
EMISSION CONTROL SYSTEM <MPI>		Component Location	10
.....	6	Positive Crankcase Ventilation System	
GENERAL INFORMATION	6	Check	10
Emission Control Device Reference Table ...	6	PCV Valve Check	10
SERVICE SPECIFICATIONS	7	EVAPORATIVE EMISSION CONTROL	
SPECIAL TOOL	7	SYSTEM	11
VACUUM HOSE	7	General Information	11
Vacuum Hose Piping Diagram	7	System Diagram	11
		Component Location	11
		Purge Control System Check	12
		Purge Port Vacuum Check	12
		Purge Control Solenoid Valve Check	13

CONTINUED ON NEXT PAGE

EXHAUST GAS RECIRCULATION (EGR) SYSTEM 14

- General Information 14
- Operation 14
- System Diagram 14
- Component Location 14
- Exhaust Gas Recirculation (EGR) Control System Check 15

- EGR Valve Check 15
- EGR Port Vacuum Check 16
- EGR Control Solenoid Valve Check 16

CATALYTIC CONVERTER 17

- General Information 17

CANISTER AND TWO-WAY VALVE 18

ENGINE CONTROL SYSTEM

17100010027

GENERAL INFORMATION

A Cable-type accelerator mechanism and a suspended-type pedal have been adopted.

SERVICE SPECIFICATIONS

17100020013

Items	Standard value
Accelerator cable play mm	1 – 2
Engine idle speed r/min	750 ± 100

SEALANT

17300050018

Items	Specified sealant	Remarks
Accelerator arm bracket mounting bolt	3M Nut Locking Part No. 4171 or equivalent	Drying sealant

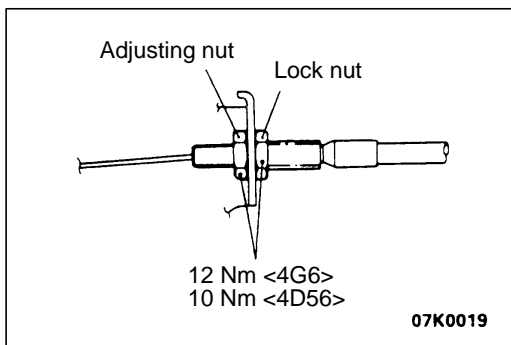

ON-VEHICLE SERVICE

17100090168

ACCELERATOR CABLE CHECK AND ADJUSTMENT

1. Turn A/C and lamps OFF.
Inspect and adjust at no load.
2. Warm engine until stabilized at idle.
3. Confirm idle speed is at prescribed value.

Standard value: 750 ± 100 r/min

4. Stop engine (ignition switch OFF).
5. Confirm there are no sharp bends in accelerator cable.
6. Check inner cable for correct slack.

Standard value: 1 – 2 mm

7. If there is too much slack or no slack, adjust play by the following procedures.
 - (1) Loosen the lock nut and fully close the throttle lever.
 - (2) Tighten the adjusting nut until immediately before the throttle lever starts to move.
 - (3) By loosening the adjusting nut one turn, the accelerator cable play will be brought to the standard value.
 - (4) Fix the adjusting nut with the lock nut.
 - (5) After adjusting, check that the throttle lever is touching the stopper.

ACCELERATOR CABLE AND PEDAL

REMOVAL AND INSTALLATION

Post-installation Operation

- Adjusting the Accelerator Cable (Refer to P. 17-3.)

<L.H. drive vehicles>

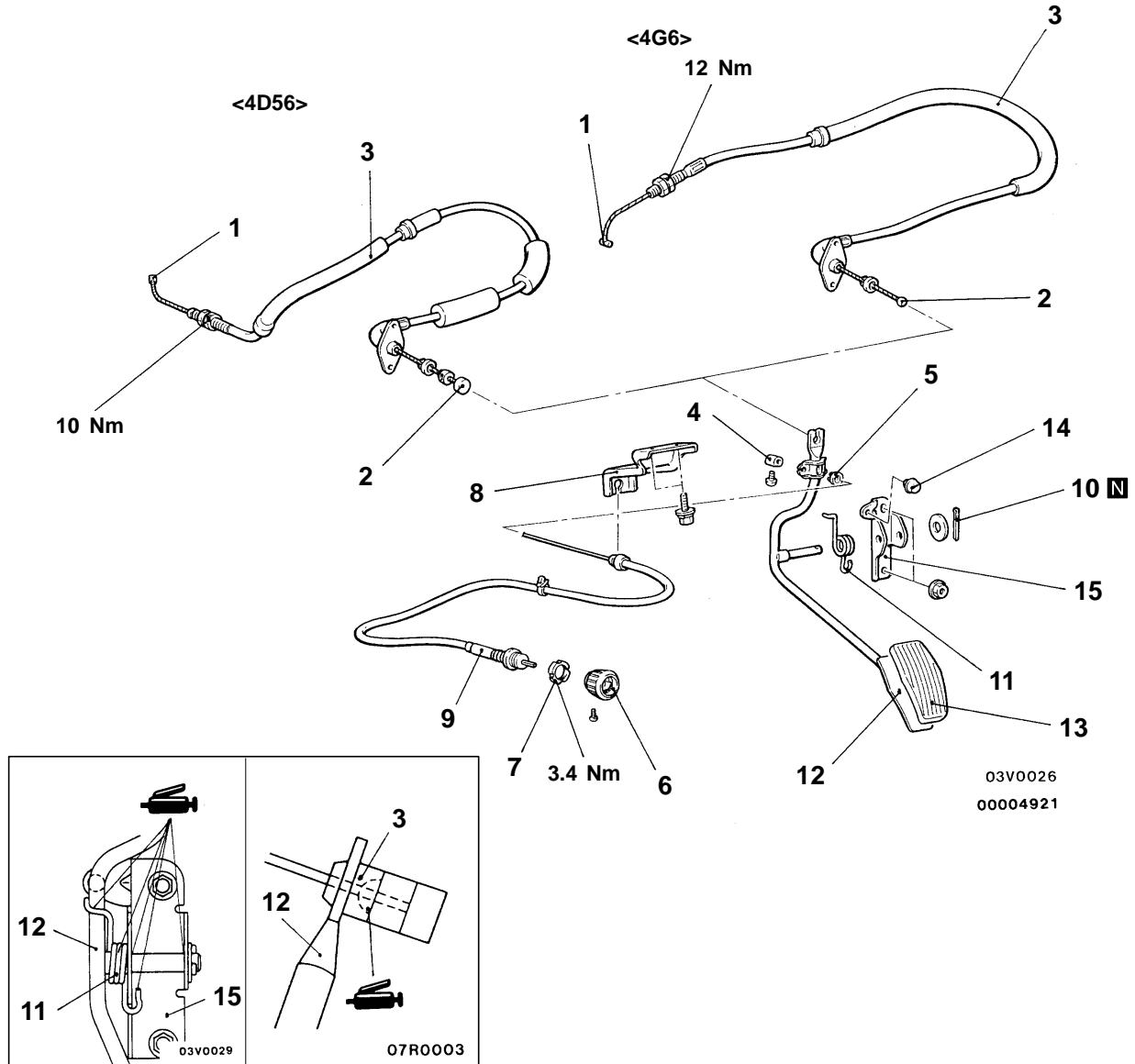
**Accelerator cable removal steps**

1. Inner cable connection (Injection pump side or throttle body side)
2. Inner cable connection (Accelerator pedal side)
3. Accelerator cable

Throttle control cable removal steps

4. Wire stopper
5. Bush
6. Knob
7. Nut

8. Cable bracket
9. Throttle cable

Accelerator pedal removal steps

2. Inner cable connection (Accelerator pedal side)
4. Wire stopper
10. Split pin
11. Spring
12. Accelerator arm
13. Pedal pad
14. Stopper
15. Bracket

<R.H. drive vehicles>

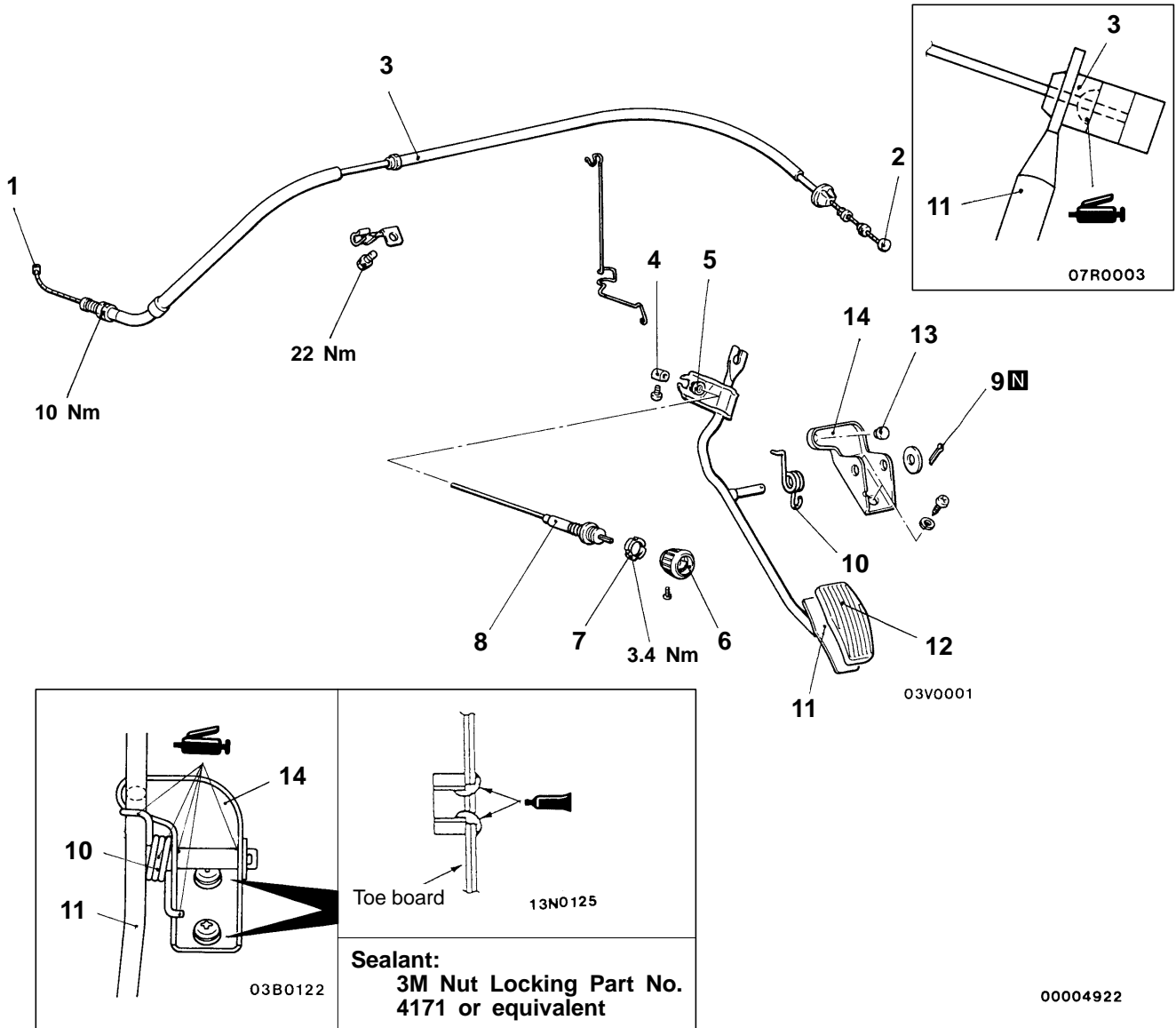

Accelerator cable removal steps

1. Inner cable connection (Injection pump side)
2. Inner cable connection (Accelerator pedal side)
3. Accelerator cable

Throttle control cable removal steps

4. Wire stopper
5. Bush
6. Knob
7. Nut
8. Throttle control cable

Accelerator pedal removal steps

2. Inner cable connection (Accelerator pedal side)
4. Wire stopper
9. Split pin
10. Spring
11. Accelerator arm
12. Pedal pad
13. Stopper
14. Bracket

00004922

EMISSION CONTROL SYSTEM <MPI>

17300010184

GENERAL INFORMATION

The emission control system consists of the following subsystems:

- Crankcase emission control system
- Evaporative emission control system
- Exhaust emission control system

Items	Name	Specification
Crankcase emission control system	Positive crankcase ventilation (PCV) valve	Variable flow type (Purpose: HC reduction)
Evaporative emission control system	Canister Purge control solenoid valve	Equipped ON/OFF type solenoid valve (Purpose: HC reduction)
Exhaust emission control system	Air-fuel ratio control device–MPI system	Oxygen sensor feedback type (Purpose: CO, HC, NOx reduction)
	Exhaust gas recirculation system <ul style="list-style-type: none"> ● EGR valve ● EGR control solenoid valve 	Equipped Single type Duty cycle type solenoid valve (Purpose: NOx reduction)
	Catalytic converter	Monolith type (Purpose: CO, HC, NOx reduction)

EMISSION CONTROL DEVICE REFERENCE TABLE

Related parts	Crankcase emission control system	Evaporative emission control system	Air/fuel ratio control system	Catalytic converter	Exhaust gas recirculation system	Reference page
PCV valve	×					17-
Purge control solenoid valve		×				17-
MPI system component		×	×			GROUP 13A
Catalytic converter				×		17-
EGR valve					×	17-
EGR control solenoid valve					×	17-

SERVICE SPECIFICATIONS

17300030173

Items	Standard value
Purge control solenoid valve coil resistance (at 20°C) Ω	36–44
EGR control solenoid valve coil resistance (at 20°C) Ω	36–44

SPECIAL TOOL

17100060022

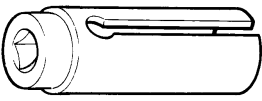
Tool	Number	Name	Use
	MD998770	Oxygen sensor wrench	Removal/Installation of oxygen sensor

VACUUM HOSE

17300090201

VACUUM HOSE PIPING DIAGRAM

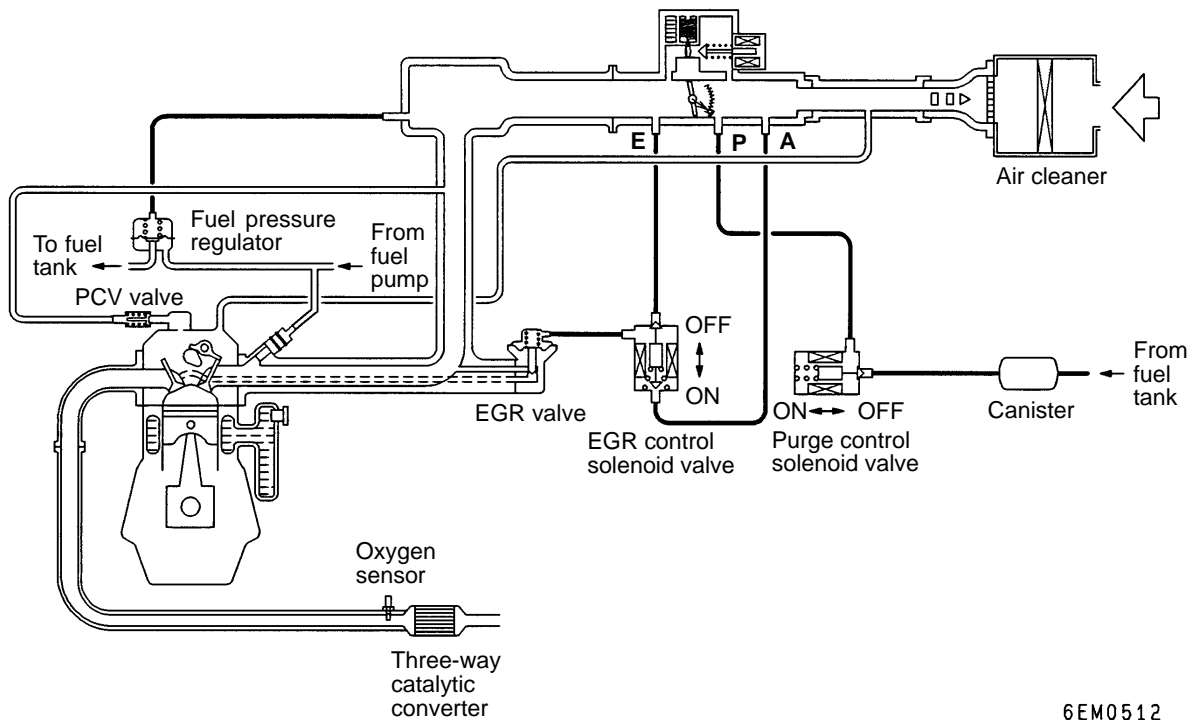

6EM0512

VACUUM CIRCUIT DIAGRAM

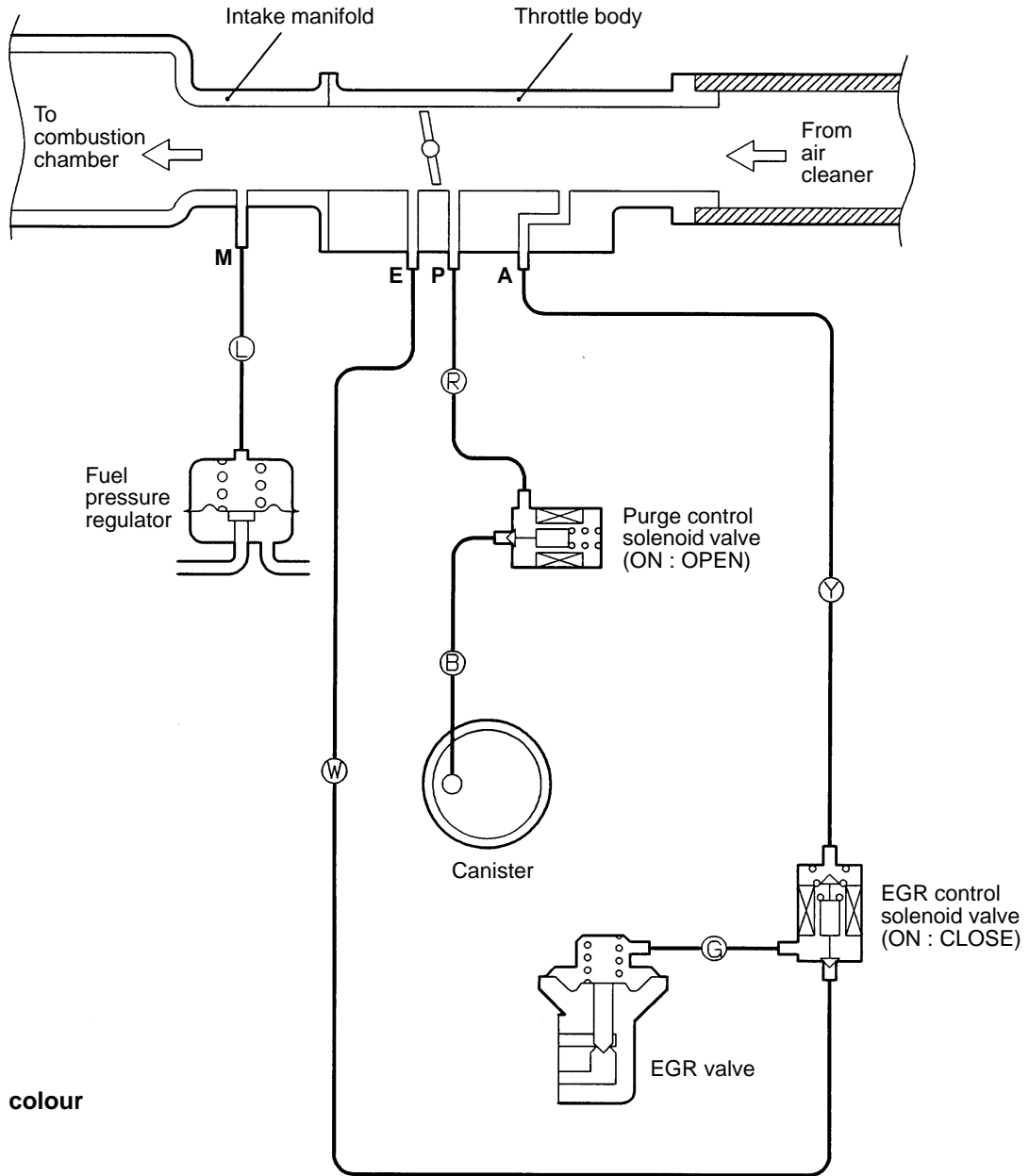

Vacuum hose colour

- B: Black
- G: Green
- L: Light blue
- R: Red
- Y: Yellow

VACUUM HOSE CHECK

1. Using the piping diagram as a guide, check to be sure that the vacuum hoses are correctly connected.
2. Check the connection condition of the vacuum hoses, (removed, loose, etc.) and check to be sure that there are no bends or damage.

VACUUM HOSE INSTALLATION

1. When connecting the vacuum hoses, they should be securely inserted onto the nipples.
2. Connect the hoses correctly, using the vacuum hose piping diagram as a guide.

CRANKCASE EMISSION CONTROL SYSTEM

17300500162

GENERAL INFORMATION

The crankcase emission control system prevents blow-by gases from escaping inside the crankcase into the atmosphere.

Fresh air is sent from the air cleaner into the crankcase through the breather hose. The air becomes mixed with the blow-by gases inside the crankcase.

The blow-by gas inside the crankcase is drawn into the intake manifold through the positive

crankcase ventilation valve.

The positive crankcase ventilation valve lifts the plunger according to the intake manifold vacuum so as to regulate the flow of blow-by gas properly. In other words, the blow-by gas flow is regulated during low load engine operation to maintain engine stability, while the flow is increased during high load operation to improve the ventilation performance.

SYSTEM DIAGRAM

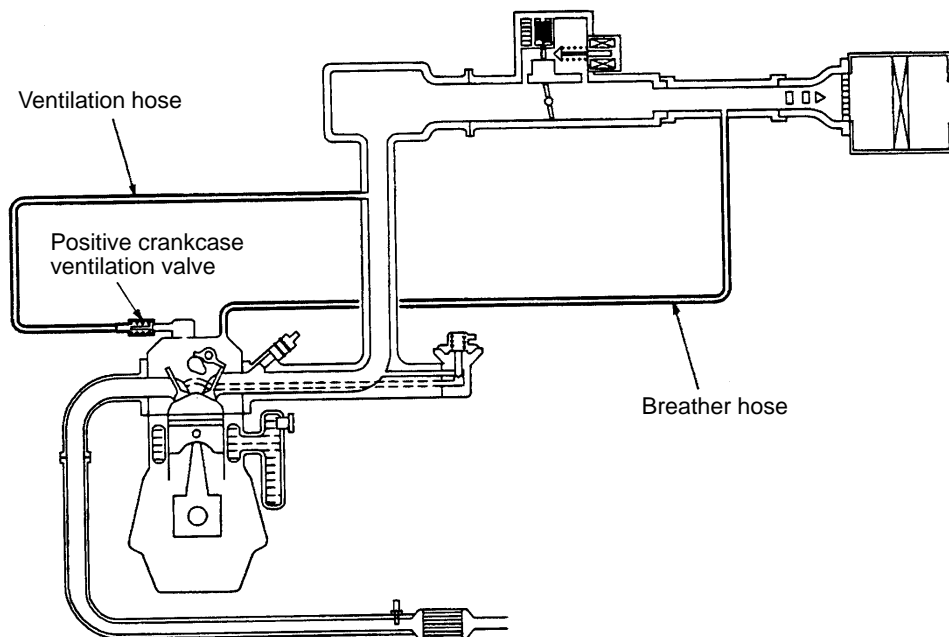

6EM0514

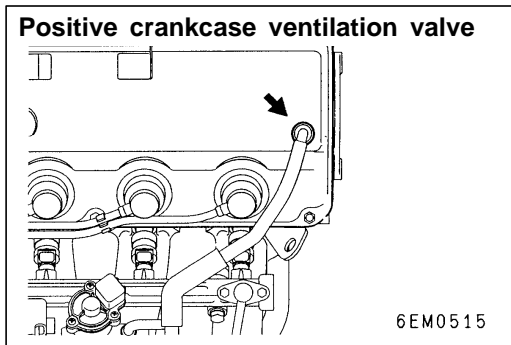
COMPONENT LOCATION**POSITIVE CRANKCASE VENTILATION SYSTEM CHECK**

17300110044

1. Remove the ventilation hose from the positive crankcase ventilation valve.
2. Remove the positive crankcase ventilation valve from the rocker cover.
3. Reinstall the positive crankcase ventilation valve at the ventilation hose.
4. Start the engine and run at idle.
5. Place a finger at the opening of the positive crankcase ventilation valve and check that vacuum of the intake manifold is felt.

NOTE

At this moment, the plunger in the positive crankcase ventilation valve moves back and forth.

6. If vacuum is not felt, clean the positive crankcase ventilation valve or replace it.

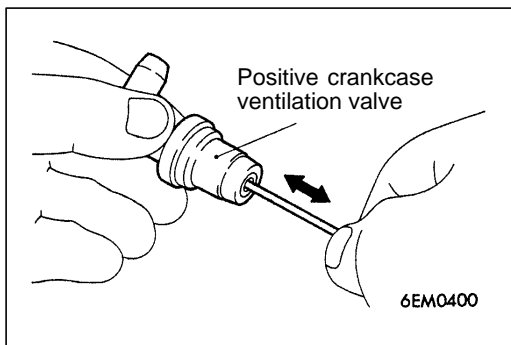
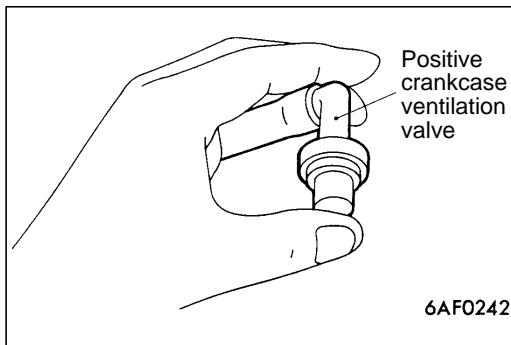
**PCV VALVE CHECK**

17300120047

1. Insert a thin rod into the positive crankcase ventilation valve from the side shown in the illustration (rocker cover installation side), and move the rod back and forth to check that the plunger moves.
2. If the plunger does not move, there is a clogging in the positive crankcase ventilation valve. In this case, clean or replace the valve.

EVAPORATIVE EMISSION CONTROL SYSTEM

17300510240

GENERAL INFORMATION

The evaporative emission control system prevents fuel vapours generated in the fuel tank from escaping into the atmosphere.

Fuel vapours from the fuel tank flow through the fuel tank pressure control valve and vapour pipe/hose to be stored temporarily in the canister. When driving the vehicle, fuel vapours stored in the canister flow through the purge solenoid and purge port and go into the intake manifold to be

sent to the combustion chamber.

When the engine coolant temperature is low or when the intake air quantity is small (when the engine is at idle, for example), the engine control unit turns the purge solenoid off to shut off the fuel vapour flow to the intake manifold.

This does not only insure the driveability when the engine is cold or running under low load but also stabilize the emission level.

SYSTEM DIAGRAM

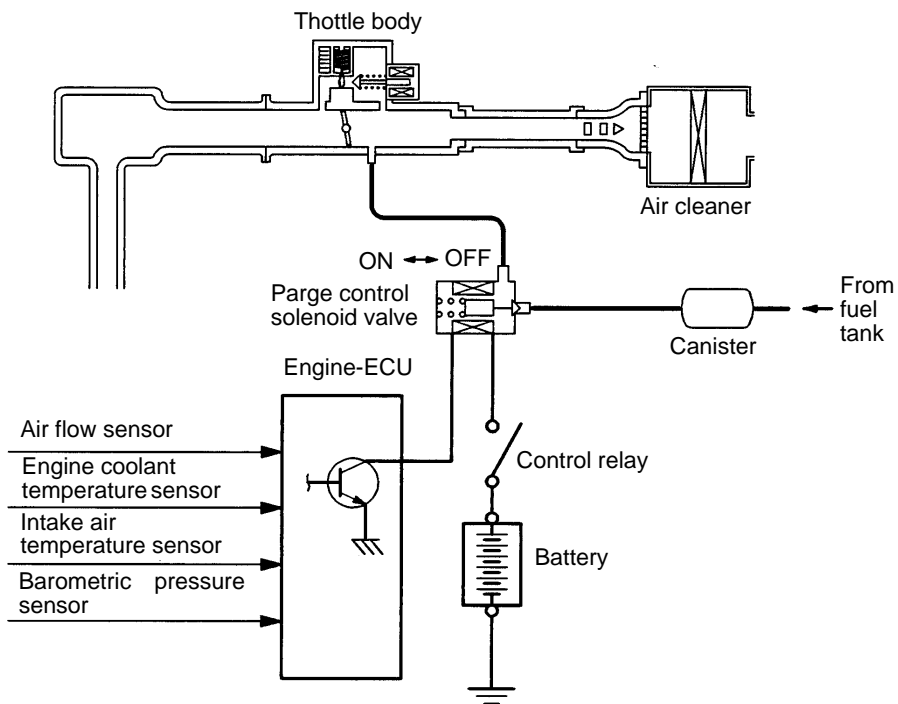

6EM0516

COMPONENT LOCATION

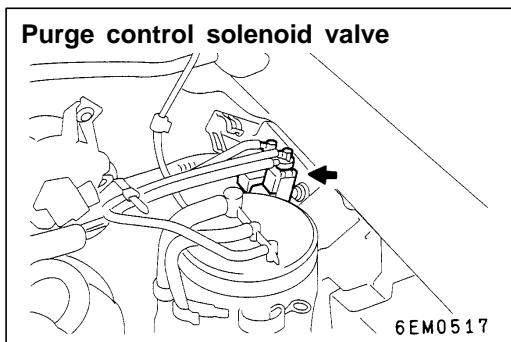

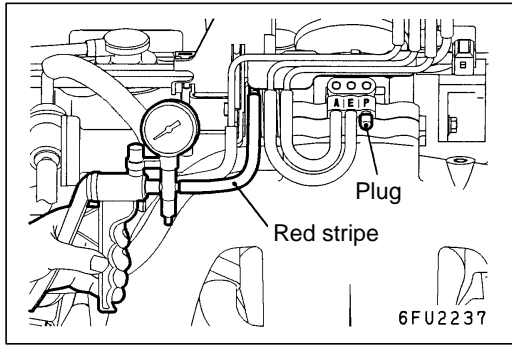

PURGE CONTROL SYSTEM CHECK

17300140241

1. Disconnect the vacuum hose (red stripe) from the throttle body and connect it to a hand vacuum pump.
2. Plug the nipple from which the vacuum hose was removed.
3. When the engine is cold or hot, apply a vacuum while the engine is idling, and check the condition of the engine and the vacuum.

**When engine is cold
(Engine coolant temperature: 40°C or less)**

Vacuum	Engine condition	Normal condition
53 kPa	3,000 r/min	Vacuum is maintained

**When engine is hot
(Engine coolant temperature: 80°C or higher)**

Vacuum	Engine condition	Normal condition
53 kPa	At idle	Vacuum is maintained
	3,000 r/min	Vacuum will leak for approximately 3 minutes after the engine is started. After 3 minutes have passed, the vacuum will be maintained momentarily, after which it will again leak.*

NOTE

*: The vacuum will leak continuously if the atmospheric pressure is approximately 77 kPa or less, or the temperature of the intake air is approximately 50°C or higher.

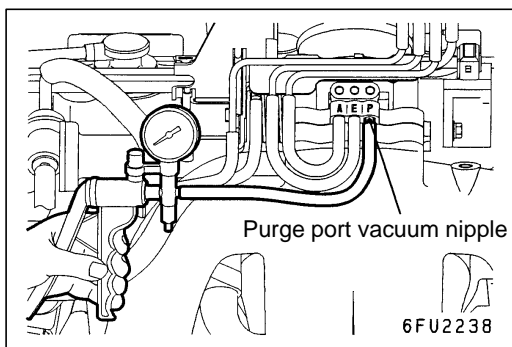

PURGE PORT VACUUM CHECK

17300150183

1. Disconnect the vacuum hose (red stripe) from the throttle body purge vacuum nipple and connect a hand vacuum pump to the nipple.

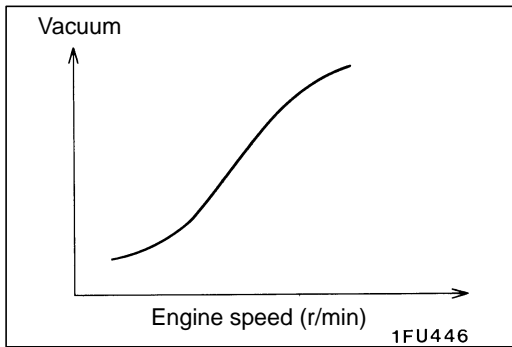

2. Start the engine and check that, after raising the engine speed by racing the engine, purge vacuum raises according to engine speed.

NOTE

If there is a problem with the change in vacuum, the throttle body purge port may be clogged and require cleaning.

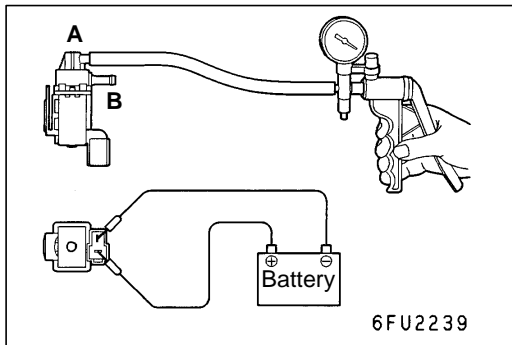

PURGE CONTROL SOLENOID VALVE CHECK

17300170172

NOTE

When disconnecting the vacuum hose, always make a mark so that it can be reconnected at original position.

1. Disconnect the vacuum hose (black stripe, red stripe) from the solenoid valve.
2. Disconnect the harness connector.
3. Connect a hand vacuum pump to nipple (A) of the solenoid valve (refer to the illustration at left).
4. Check airtightness by applying a vacuum with voltage applied directly from the battery to the purge control solenoid valve and without applying voltage.

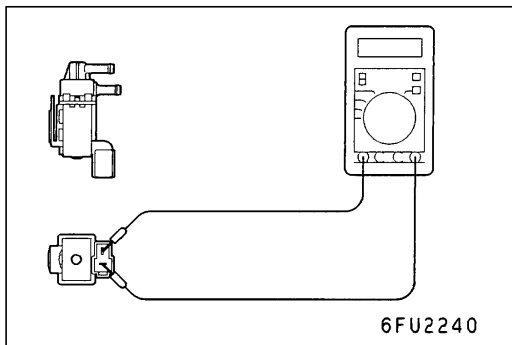

Battery voltage	Normal condition
Applied	Vacuum leaks
Not applied	Vacuum maintained

5. Measure the resistance between the terminals of the solenoid valve.

Standard value: 36 – 44 Ω (at 20°C)

EXHAUST GAS RECIRCULATION (EGR) SYSTEM

17300520182

GENERAL INFORMATION

The exhaust gas recirculation (EGR) system lowers the nitrogen oxide (NOx) emission level. When the air/fuel mixture combustion temperature is high, a large quantity of nitrogen oxides (NOx) is generated in the combustion chamber. Therefore, this system recirculates part of emission gas from

the exhaust port of the cylinder head to the combustion chamber through the intake manifold to decrease the air/fuel mixture combustion temperature, resulting in reduction of NOx. The EGR flow rate is controlled by the EGR valve so as not to decrease the driveability.

OPERATION

The EGR valve is being closed and does not recirculate exhaust gases under one of the following conditions. Otherwise, the EGR valve is opened and recirculates exhaust gases.

- The engine coolant temperature is low.
- The engine is at idle.
- The throttle valve is widely opened.

SYSTEM DIAGRAM

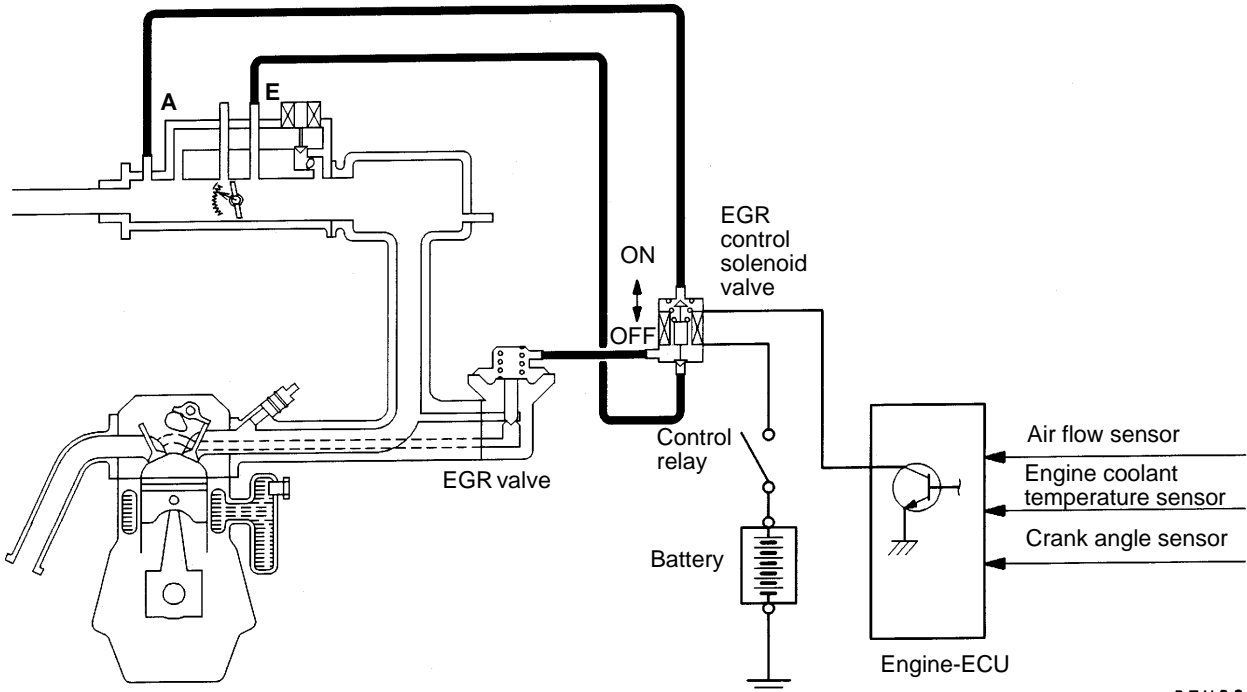

6FU2241

COMPONENT LOCATION

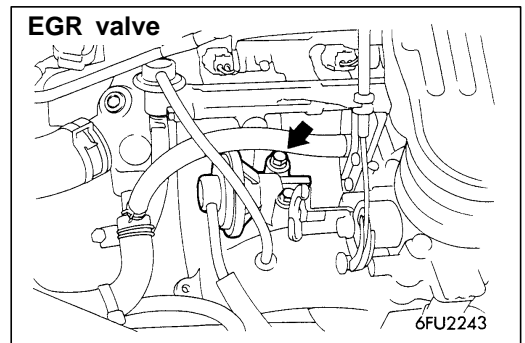
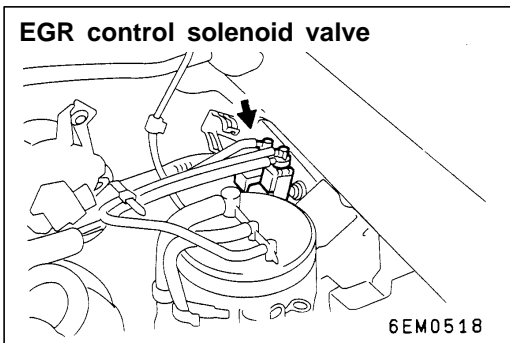

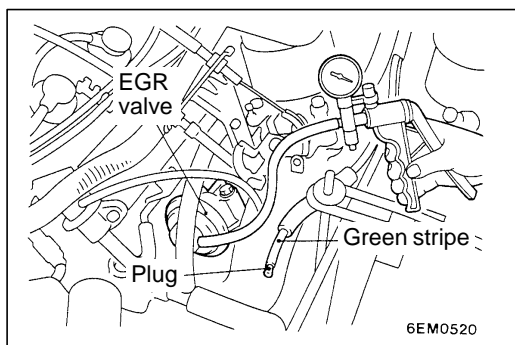
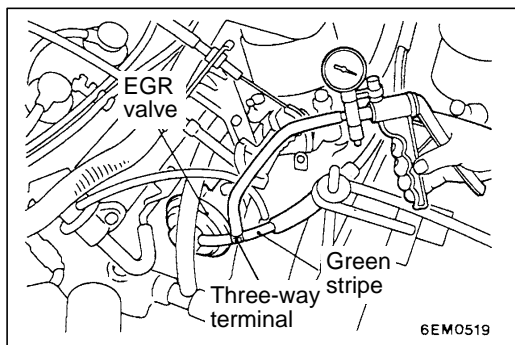

EXHAUST GAS RECIRCULATION (EGR) CONTROL SYSTEM CHECK

17300260206

1. Disconnect the vacuum hose (green stripe) from the EGR valve, and then connect a hand vacuum pump via the three-way terminal.
2. When the engine is hot or cold, check the condition of vacuum by racing the engine.

**When engine is cold
(Engine coolant temperature: 20°C or less)**

Throttle valve	Normal vacuum condition
Open quickly	No vacuum will generate (the same as barometric pressure.)

**When engine is hot
(Engine coolant temperature: 80°C or higher)**

Throttle valve	Normal vacuum condition
Open quickly	It will momentarily rise over 13 kPa

3. Disconnect the three-way terminal.
4. Connect the hand vacuum pump to the EGR valve.
5. Check whether the engine stalls or the idling is unstable when a vacuum of 30 kPa or higher is applied during idling.

EGR VALVE CHECK

17300280042

1. Remove the EGR valve and inspect for sticking, carbon deposits, etc. If found, clean with a suitable solvent so that the valve seats correctly.
2. Connect a hand vacuum pump to the EGR valve.
3. Apply 67 kPa of vacuum, and check that the vacuum is maintained.

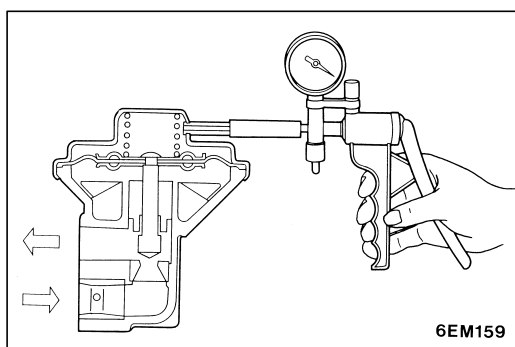

4. Apply a vacuum and check the passage of air by blowing through one side of the EGR passage.

Vacuum	Passage of air
5.3 kPa or less	Air is not blown out
26 kPa or more	Air is blown out

5. Replace the gasket, and tighten to the specified torque.

Specified torque: 22 Nm

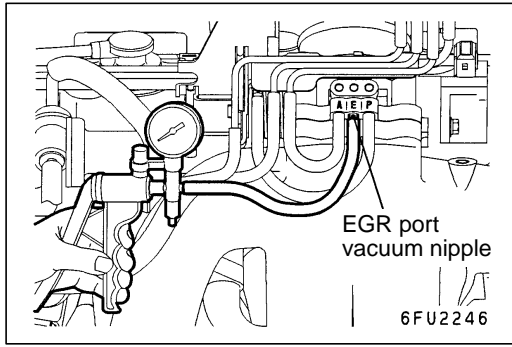

EGR PORT VACUUM CHECK

17300290144

1. Disconnect the vacuum hose (green stripe) from the throttle body EGR vacuum nipple and connect a hand vacuum pump to the nipple.

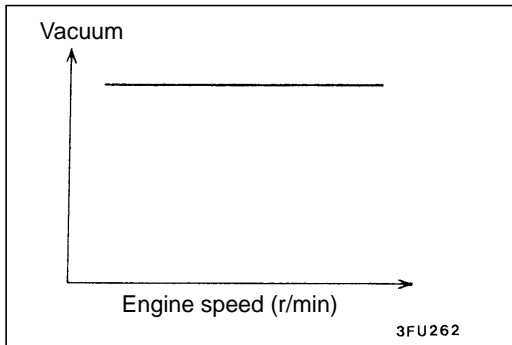

2. Start the engine and check vacuum remains fairly constant after racing the engine.

NOTE

If the vacuum fluctuates, the throttle body EGR port may be clogged and need cleaning.

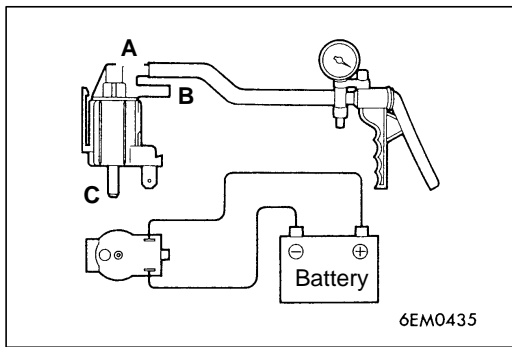

EGR CONTROL SOLENOID VALVE CHECK

17300310161

NOTE

When disconnecting the vacuum hose, always make a mark so that it can be reconnected at original position.

1. Disconnect the vacuum hose (yellow stripe, white stripe, green stripe) from the solenoid valve.
2. Disconnect the harness connector.
3. Connect a hand vacuum pump to the nipple to which the white-striped vacuum hose was connected.
4. Check airtightness by applying a vacuum with voltage applied directly from the battery to the EGR control solenoid valve and without applying voltage.

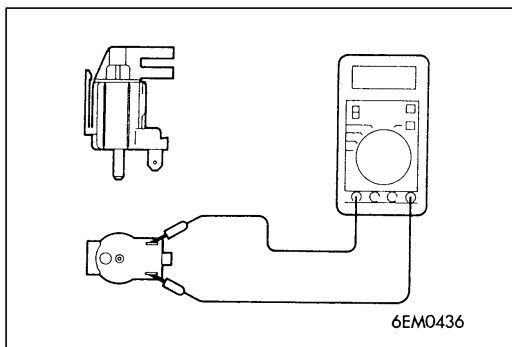

Battery voltage	B nipple condition	Normal condition
Not applied	Open	Vacuum maintained
Applied	Open	Vacuum leaks
	Closed	Vacuum maintained

5. Measure the resistance between the terminals of the solenoid valve.

Standard value: 36 – 44Ω (at 20°C)

CATALYTIC CONVERTER

17300530123

GENERAL INFORMATION

The three-way catalytic converter, together with the closed loop air-fuel ration control based on the oxygen sensor signal, oxidizes carbon monoxides (CO) and hydrocarbons (HC) and reduces nitrogen oxides (NOx).

When the mixture is controlled at stoichiometric air-fuel ratio, the three-way catalytic converter provides the highest purification against the three constituents, namely, CO, HC and Nox.

REMOVAL AND INSTALLATION

17300390141

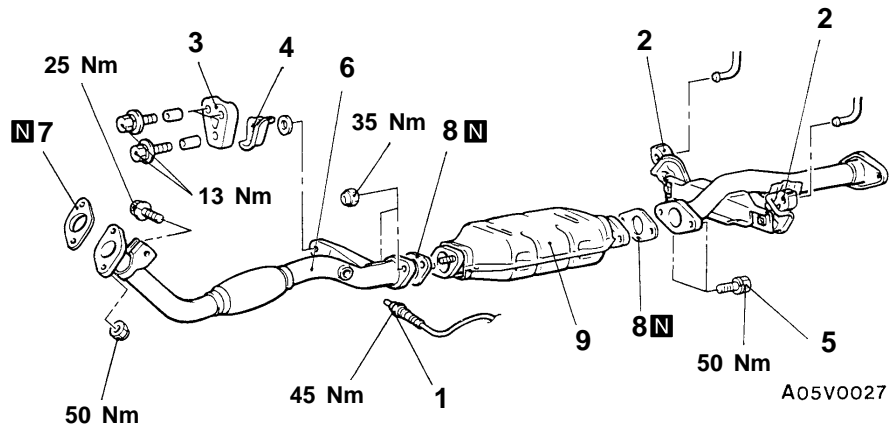

Removal steps



1. Oxygen sensor
2. Center exhaust pipe hanger connection
3. Front exhaust pipe hanger
4. Heat protector

5. Catalytic converter attaching bolt
6. Front exhaust pipe
7. Gasket
8. Gasket
9. Catalytic converter

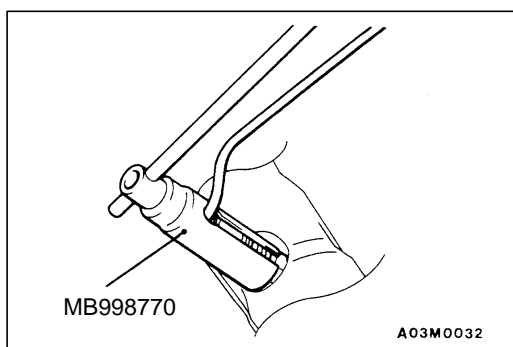

REMOVAL SERVICE POINT

◀▶ OXYGEN SENSOR REMOVAL

INSTALLATION SERVICE POINT

▶▶ OXYGEN SENSOR INSTALLATION

INSPECTION

17300400066

Check for damage, cracking or deterioration. Replace if faulty.

Caution

1. Stop the engine immediately if engine misfiring occurs, otherwise an abnormally hot exhaust system will damage the catalytic converter or other underbody parts.
2. Correct and repair the ignition or fuel system if there are malfunctions, otherwise engine misfiring may occur which will damage the catalytic converter.
3. Observe manufacturer's specifications when doing service work.

CANISTER AND TWO-WAY VALVE REMOVAL AND INSTALLATION

17300480121

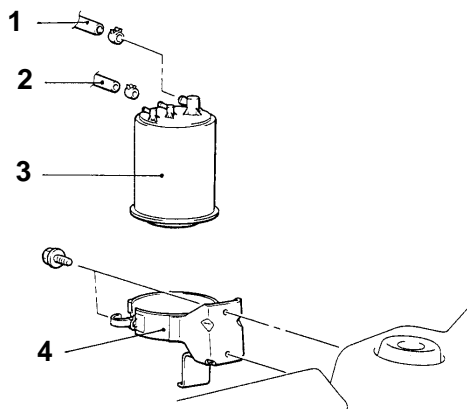

03V0025

<Diesel-powered vehicles>

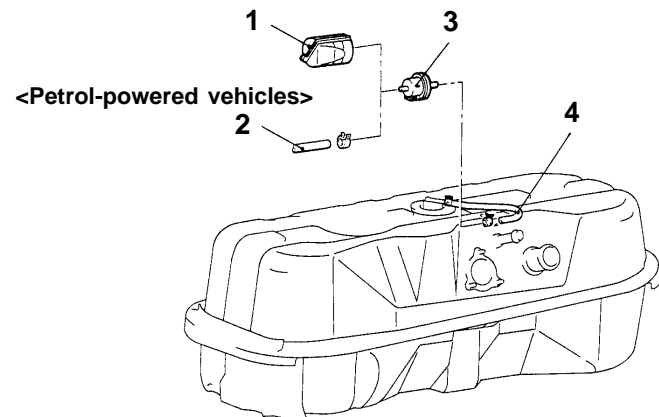

<Petrol-powered vehicles>

03V0028
00004923**Canister removal steps**

1. Breather hose connection
2. Vapour hose connection
3. Canister
4. Canister holder

Two-way valve removal steps

- Rear body side gate stay (L.H.)
1. Breather case
 2. Vapour hose connection
 3. Two-way valve
 4. Vapour hose



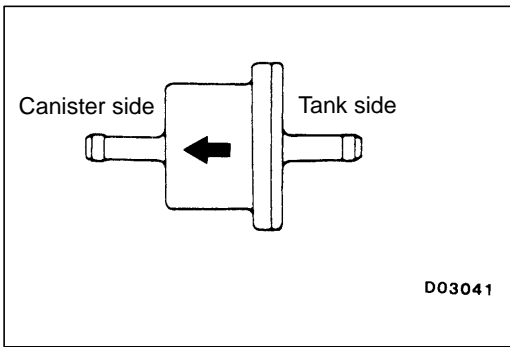

INSTALLATION SERVICE POINT

▶◀ TWO-WAY VALVE INSTALLATION

Be careful about the installation direction of the two-way valve.

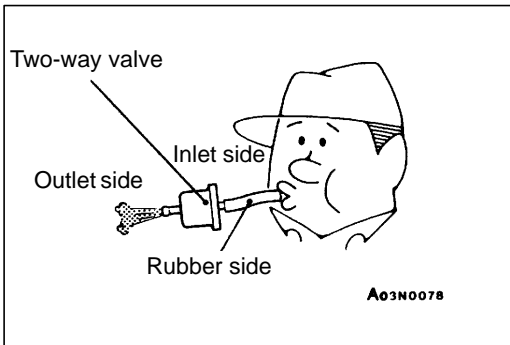

INSPECTION

17300490063

TWO-WAY VALVE SIMPLE CHECK

Attach a clean hose and check the operation of the two-way valve.

Lightly blow from inlet side (fuel tank side.)	Air passes through with a slight feeling of resistance.
Lightly blow from outlet side.	Air passes through.

NOTES

GROUP 17

ENGINE AND EMISSION CONTROL

EMISSION CONTROL SYSTEM <DIESEL>

GENERAL

OUTLINE OF CHANGE(S)

The engine with the exhaust gas recirculation (EGR) system has been newly used. Therefore, service procedure has been added.

GENERAL INFORMATION

The electronically-controlled EGR system and the fuel injection timing control system (load timer) reduce the level of exhaust gases (NOx).

Item	Name	Specification
Exhaust emission control system	Exhaust gas recirculation system <ul style="list-style-type: none"> • EGR valve • EGR solenoid valve No.1 • EGR solenoid valve No.2 	Electronically-controlled EGR system Single type Duty cycle solenoid valve ON-OFF solenoid valve

SERVICE SPECIFICATIONS

Item	Standard value	
EGR solenoid valve Nos.1 and 2 resistance (at 20°C) Ω	36 – 44	
Lever position sensor output voltage V	Idle position	0.8 – 1.0
	Fully open	3.7 – 5.0
Engine speed sensor resistance kΩ	1.3 – 1.9	
Engine coolant temperature sensor resistance kΩ	At 20°C	2.9 – 3.6
	At 80°C	0.26 – 0.35

SEALANT

Item	Specified sealant	Remark
Engine coolant temperature sensor threaded portion	3M Nut Locking Part No. 4171 or equivalent	Drying sealant

SPECIAL TOOL

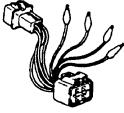
Tool	Number	Name	Use
	MD998464	Test harness (4P, square)	Inspection of lever position sensor

EXHAUST GAS RECIRCULATION (EGR) SYSTEM

GENERAL INFORMATION

The electronically-controlled EGR system consists of an EGR valve, a vacuum pump, EGR solenoid valves Nos.1 and 2, a glow & EGR control unit and various sensors.

The EGR valve is controlled by the negative pressure inside the valve, which is controlled by EGR solenoid valves Nos.1 and 2.

EGR solenoid valves Nos. 1 and 2 are optimally controlled by the glow & EGR control unit in response to the engine operation conditions, based on data received from each sensor.

In this way, the EGR is controlled to reduce NOx emissions while maintaining good engine performance.

SYSTEM DIAGRAM

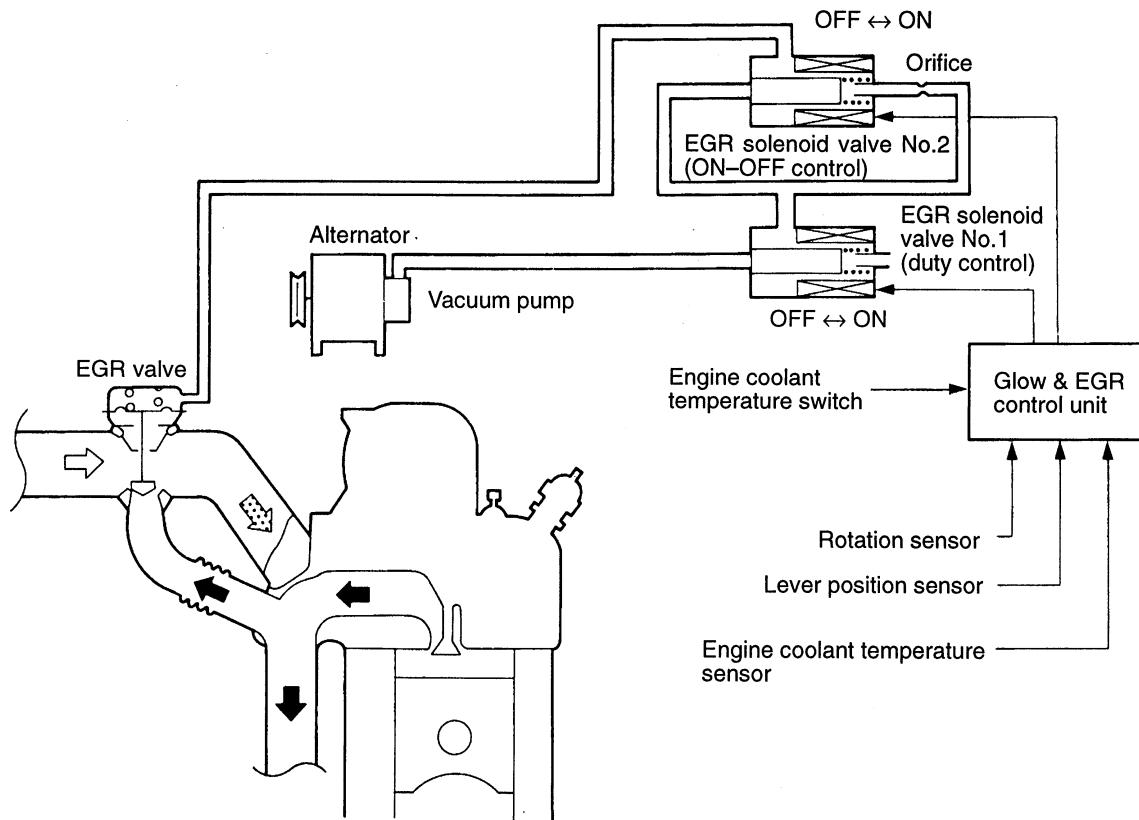

DEM0662

COMPONENT LOCATION

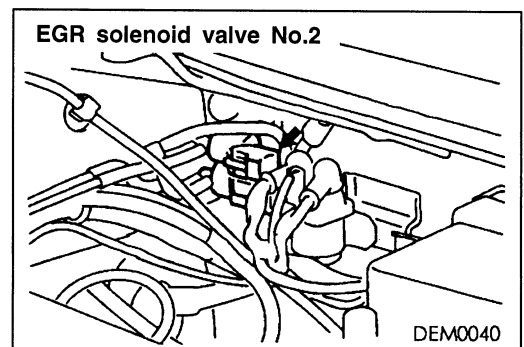
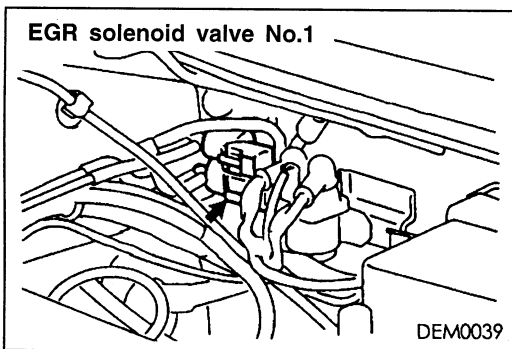

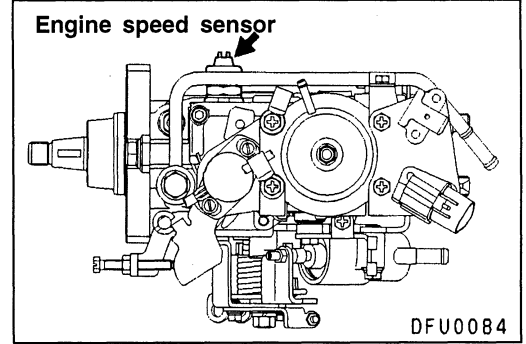
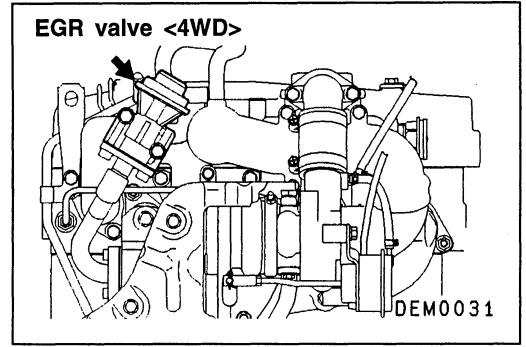
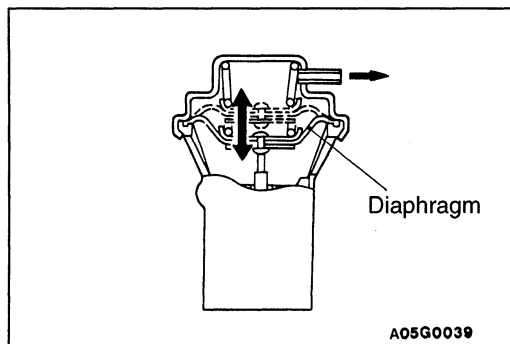
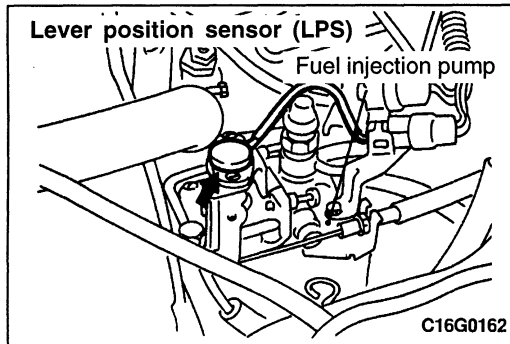
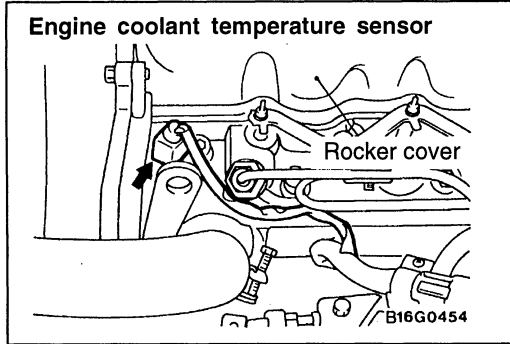
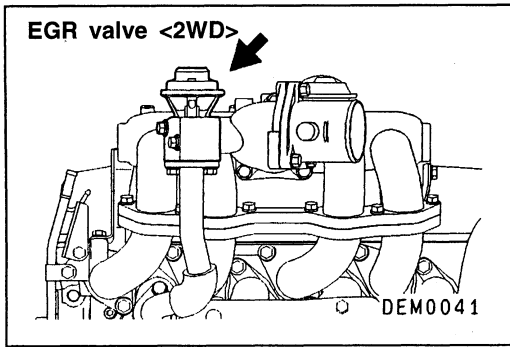

FUNCTION INSPECTION

1. Start the engine and warm it up until the engine coolant temperature reaches 65°C or above.
2. Race the engine by suddenly depressing the accelerator pedal, then check that the EGR valve diaphragm lifts.

EGR SOLENOID VALVE OPERATION INSPECTION

1. Remove EGR solenoid valve Nos. 1 and 2 connectors and vacuum hoses.
2. Attach a vacuum pump to each nipple of the EGR solenoid valve Nos. 1 and 2 connectors and apply negative pressure. Check that the valves are airtight both when voltage is applied to each terminal of the EGR solenoid valve Nos. 1 and 2 and when it is not applied.

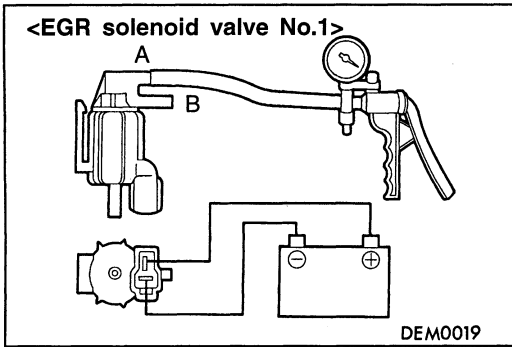

EGR solenoid valve No.1

Battery voltage	Normal condition
When current is flowing	Vacuum leaks (Vacuum is maintained when nipple B is plugged)
When current is not flowing	Vacuum is maintained

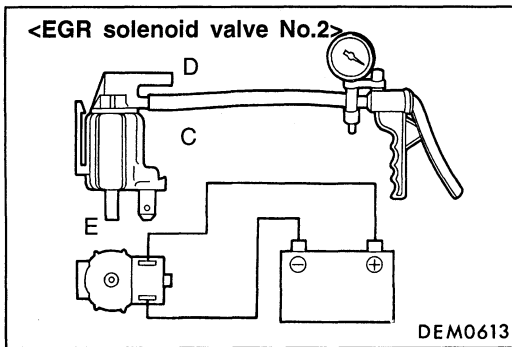

EGR solenoid valve No.2

Battery voltage	Normal condition
When current is flowing	Vacuum leaks (Vacuum is maintained when nipple D is plugged)
When current is not flowing	Vacuum leaks (Vacuum is maintained when nipple E is plugged)

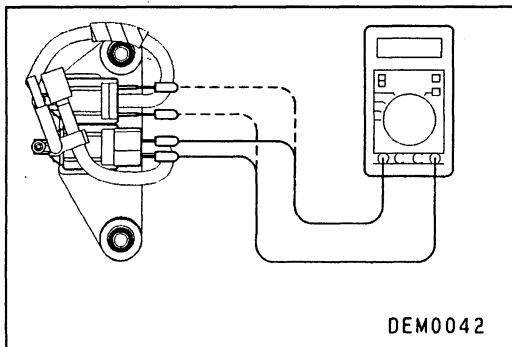

EGR SOLENOID VALVE RESISTANCE INSPECTION

Measure terminal resistance of EGR solenoid valves Nos.1 and 2 with a circuit tester.

Standard value: 36 – 44 Ω (at 20°C)

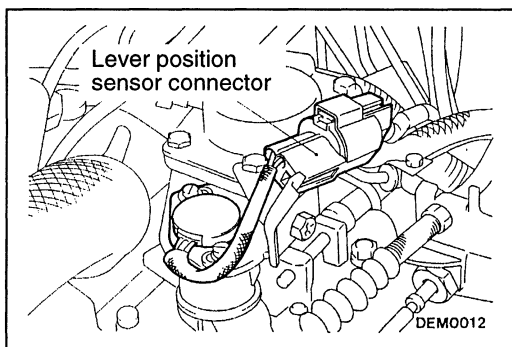

LEVER POSITION SENSOR (LPS) ADJUSTMENT

1. Run the engine until the engine coolant temperature reaches 80°C or above, and then release the fast idle.
2. Loosen the accelerator cable tension sufficiently.
3. Connect the special tool (test harness) to the lever position sensor connector, as shown.

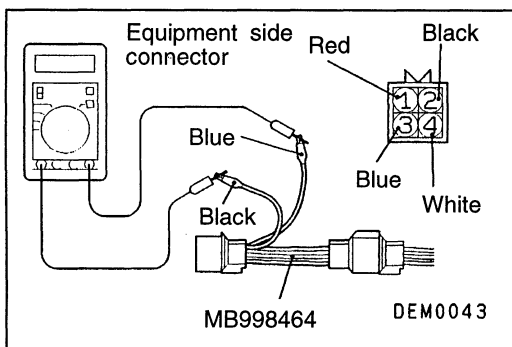

4. Connect a digital-type voltmeter between lever position sensor terminals 1 (red clip) and 3 (blue clip).
5. Turn the ignition switch "ON". (Do not start the engine.)
6. Measure output voltage of the lever position sensor.

Standard value:

Lever condition	Voltage V
Idle position	0.8 – 1.0
Fully open	3.7 – 5.0

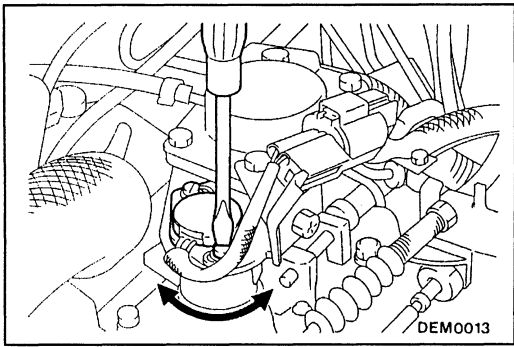

7. If the voltage is outside the standard value, adjust by loosening the lever position sensor mounting screw and turning the lever position sensor body. After adjustment, tighten the screw.

NOTE

Voltage increases when the lever position sensor body is turned clockwise.

8. Turn the ignition switch off.
9. Adjust the accelerator cable play.

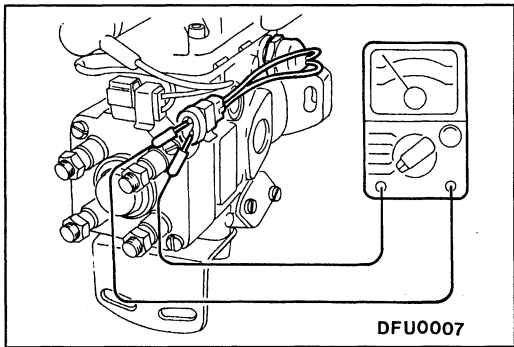
**ENGINE SPEED SENSOR INSPECTION**

1. Disconnect the engine speed sensor connector.
2. Measure resistance between the engine speed sensor terminals.

Standard value: 1.3 – 1.9 kΩ

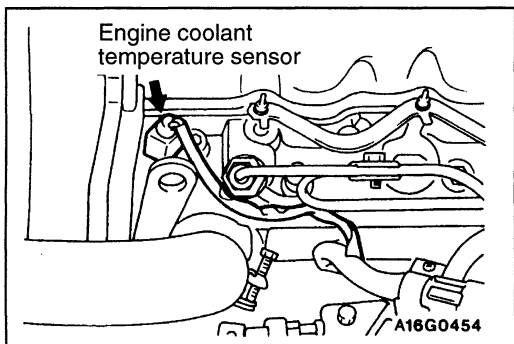
**ENGINE COOLANT TEMPERATURE SENSOR INSPECTION**

1. Remove the engine coolant temperature sensor.

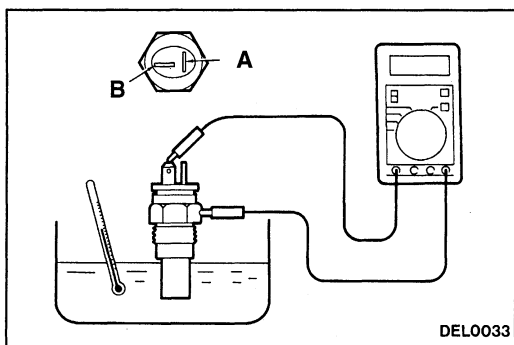

2. Measure resistance between terminal (B) and the body earth when the temperature sensing portion of the engine coolant temperature sensor is immersed in hot water.

Temperature (°C)	Resistance (kΩ)
0	7.7 – 9.5
20	2.9 – 3.6
40	1.3 – 1.7
80	0.26 – 0.35

3. If the resistance deviates from the standard value greatly, replace the sensor.
4. Apply sealant to the threaded portion.

Specified sealant: 3M NUT Locking Part No. 4171 or equivalent

5. Install the engine coolant temperature sensor and tighten it to the specified torque.

Sensor tightening torque: 35 Nm

6. Connect the wiring harness connectors.

CHECK AT THE GLOW & EGR CONTROL UNIT

TERMINAL VOLTAGE CHECK CHART

Glow & EGR Control Unit Connector Terminal Arrangement

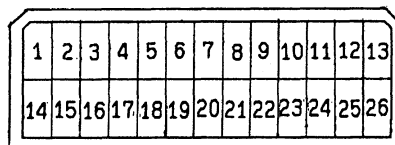

DEM0029

Terminal No.	Check item	Check condition (Engine condition)	Normal condition
3	EGR solenoid valve No.1	Ignition switch: ON	Battery voltage
		While engine is idle after having warmed up, suddenly depress the accelerator pedal.	Momentarily increases
6	Lever position sensor	Ignition switch: ON	Set throttle lever to idle position 0.8 – 1.0 V
			Fully open throttle lever 3.5 – 5.0 V
7	Sensor impressed voltage	Ignition switch: ON	4.5 – 5.5 V
16	EGR solenoid valve No.2	Ignition switch: ON	Battery voltage
		While engine is idle after having warmed up, suddenly depress the accelerator pedal.	Momentarily decreases

HARNESS-SIDE CONNECTOR TERMINAL RESISTANCE AND CONTINUITY CHECK CHART

Glow & EGR Control Unit Harness-Side Connector Terminal Arrangement

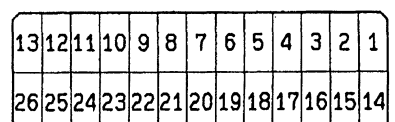

DEM0026

Terminal No.	Check item	Normal condition (Check condition)
3 – 1	EGR solenoid valve No.1	36 – 44 Ω (At 20°C)
5 – Body earth	Engine coolant temperature sensor	7.7 – 9.5 kΩ (Coolant temperature at 0°C)
		2.9 – 3.6 kΩ (Coolant temperature at 20°C)
		1.3 – 1.7 kΩ (Coolant temperature at 40°C)
		0.26 – 0.35 kΩ (Coolant temperature at 80°C)
11 – 24	Engine speed sensor	1.3 – 1.9 kΩ
16 – 1	EGR solenoid valve No.2	36 – 44 Ω (At 20°C)

ENGINE AND EMISSION CONTROL

CONTENTS

ENGINE CONTROL SYSTEM <DIESEL>	2	EMISSION CONTROL SYSTEM <DIESEL>	5
GENERAL	2	GENERAL	5
Outline of Change	2	Outline of Change	5
SEALANT <4D56-Step III>	2	SERVICE SPECIFICATION	5
ACCELERATOR PEDAL <4D56-Step III>	3	EXHAUST GAS RECIRCULATION (EGR) SYSTEM <4D56-Step III>	5
EMISSION CONTROL SYSTEM <MPI>	4	General Information	5
GENERAL	4	System Diagram	5
Outline of Change	4	Component Location	6
SERVICE SPECIFICATIONS	4	Function Check	6
EVAPORATIVE EMISSION CONTROL SYSTEM	4	EGR Solenoid Valve Operation Check	6
Purge Control Solenoid Valve Check	4	EGR Solenoid Valve Resistance Check	7
		Accelerator Pedal Position Sensor (APS), Engine Coolant Temperature Sensor, Boost Air Temperature Sensor, Fuel Temperature Sensor, EGR Valve Position Sensor Check	7
		Check at the Engine-ECU Terminals	7
		EGR VALVE, EGR COOLER <4D56-Step III>	8

ENGINE CONTROL SYSTEM <DIESEL>

GENERAL

OUTLINE OF CHANGE

Since the emission regulation step III compatible 4D56 engine has been added, the following has been changed. Due to this, the service procedures regarding the different description from the previous version have been established.

- Due to the introduction of the electronic-controlled injection pump, the accelerator cable has been abolished, and the accelerator pedal position sensor has been added.

SEALANT <4D56-Step III>

Items	Specified sealant	Remarks
Accelerator arm bracket mounting bolt	3M Nut Locking Part No. 4171 or equivalent	Drying sealant

ACCELERATOR PEDAL <4D56-Step III>**REMOVAL AND INSTALLATION****Post-installation Operation**

- Accelerator Pedal Position Sensor Check and Adjustment
(Refer to GROUP 13I – On-vehicle Service.)

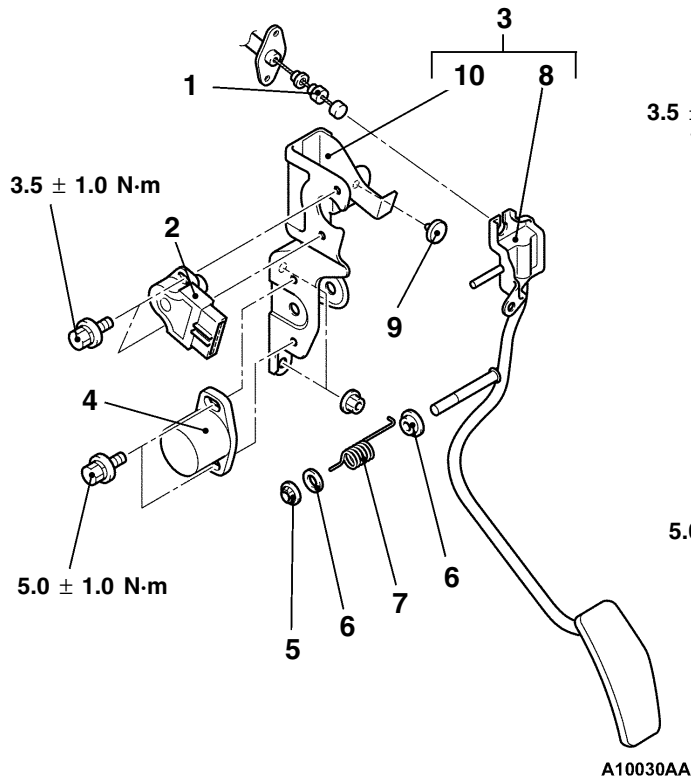
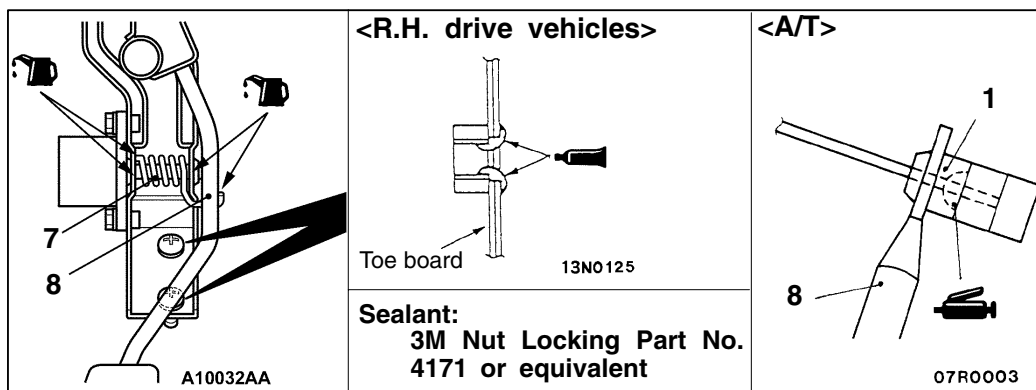
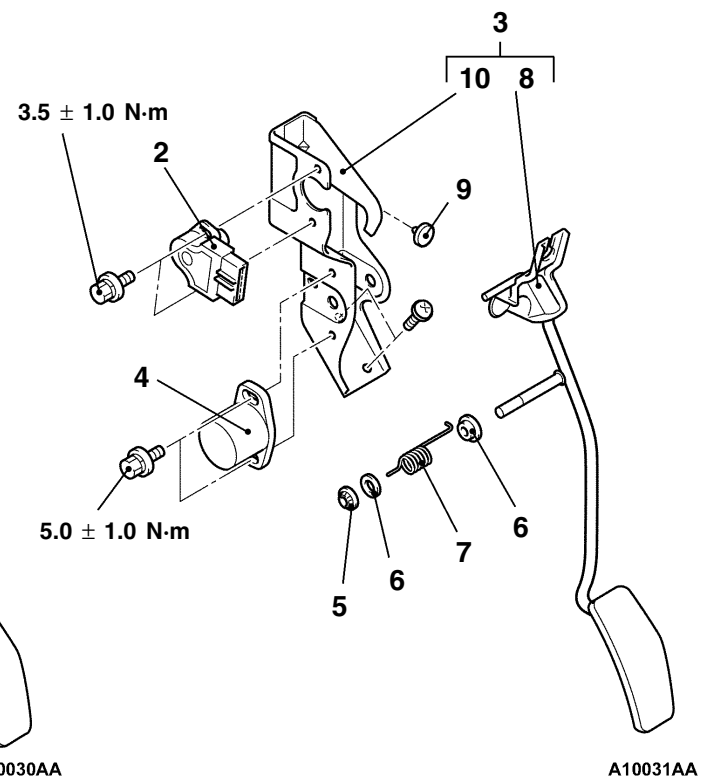
<L.H. drive vehicles>**<R.H. drive vehicles>****Removal steps**

1. Accelerator cable connection (for automatic transmission kickdown) <A/T>
2. Accelerator pedal position sensor
3. Accelerator pedal assembly
4. Hysteresis assembly <M/T>
5. Push-on spring nut
6. Bushing
7. Spring
8. Accelerator pedal
9. Pedal stopper
10. Accelerator pedal bracket

EMISSION CONTROL SYSTEM <MPI>

GENERAL

OUTLINE OF CHANGE

A new purge control solenoid valve, which flow rate is enhanced, has been used. Due to this, the service procedures regarding the different description from the previous version have been established.

SERVICE SPECIFICATIONS

Item	Standard value
Purge control solenoid valve coil resistance (at 20°C) Ω	30 – 34

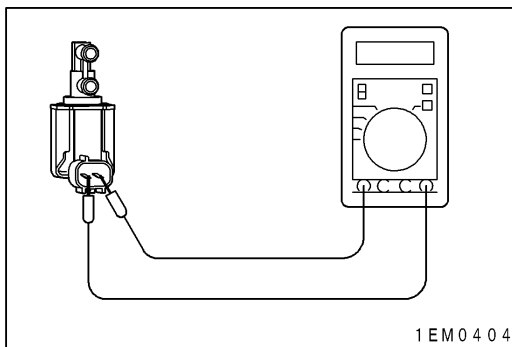
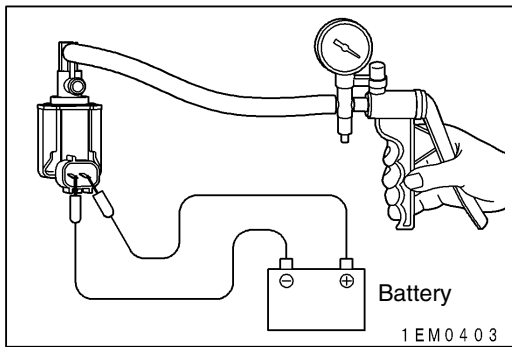

EVAPORATIVE EMISSION CONTROL SYSTEM

PURGE CONTROL SOLENOID VALVE CHECK

NOTE

When disconnecting the vacuum hose, always make a mark so that it can be reconnected at original position.

1. Disconnect the vacuum hoses from the solenoid valve.
2. Disconnect the harness connector.
3. Connect a hand vacuum pump to nipple (A) of the solenoid valve (refer to the illustration at left).
4. Check airtightness by applying a vacuum with voltage applied directly from the battery to the purge control solenoid valve and without applying voltage.

Battery voltage	Normal condition
Applied	Vacuum leaks.
Not applied	Vacuum is maintained.

5. Measure the resistance between the terminals of the solenoid valve.

Standard value: 30 – 34 kΩ (at 20°C)

EMISSION CONTROL SYSTEM <DIESEL>

GENERAL

OUTLINE OF CHANGE

Since the emission regulation step III compatible 4D56 engine has been added, the following has been changed. Due to this, the service procedures regarding the different description from the previous version have been established.

- The electronic-controlled EGR valve has been adopted, and EGR cooler has been added.

SERVICE SPECIFICATION

Item	Standard value
EGR solenoid valve No.1/No.2 resistance (at 20°C) Ω	36 – 44

EXHAUST GAS RECIRCULATION (EGR) SYSTEM <4D56-Step III>

GENERAL INFORMATION

The electronic-controlled EGR system consists of an EGR valve, vacuum pump, EGR solenoid valves No. 1 and No.2, EGR valve position sensor and engine-ECU and various sensors.

The EGR valve is controlled by the negative pressure inside the valve, which is controlled by EGR solenoid valves No. 1 and No.2.

In order to obtain EGR amount corresponding to each operating condition, the appropriate opening of the EGR valve is calculated based on the input signal from each sensor.

Feedback control of the EGR solenoid valves No. 1 and No. 2 operation is carried out based on the signal from EGR valve position sensor so that the opening of the EGR valve can be quickly adjusted to the target angle.

In this way, the EGR is controlled to reduce NO_x emissions while maintaining good engine performance.

SYSTEM DIAGRAM

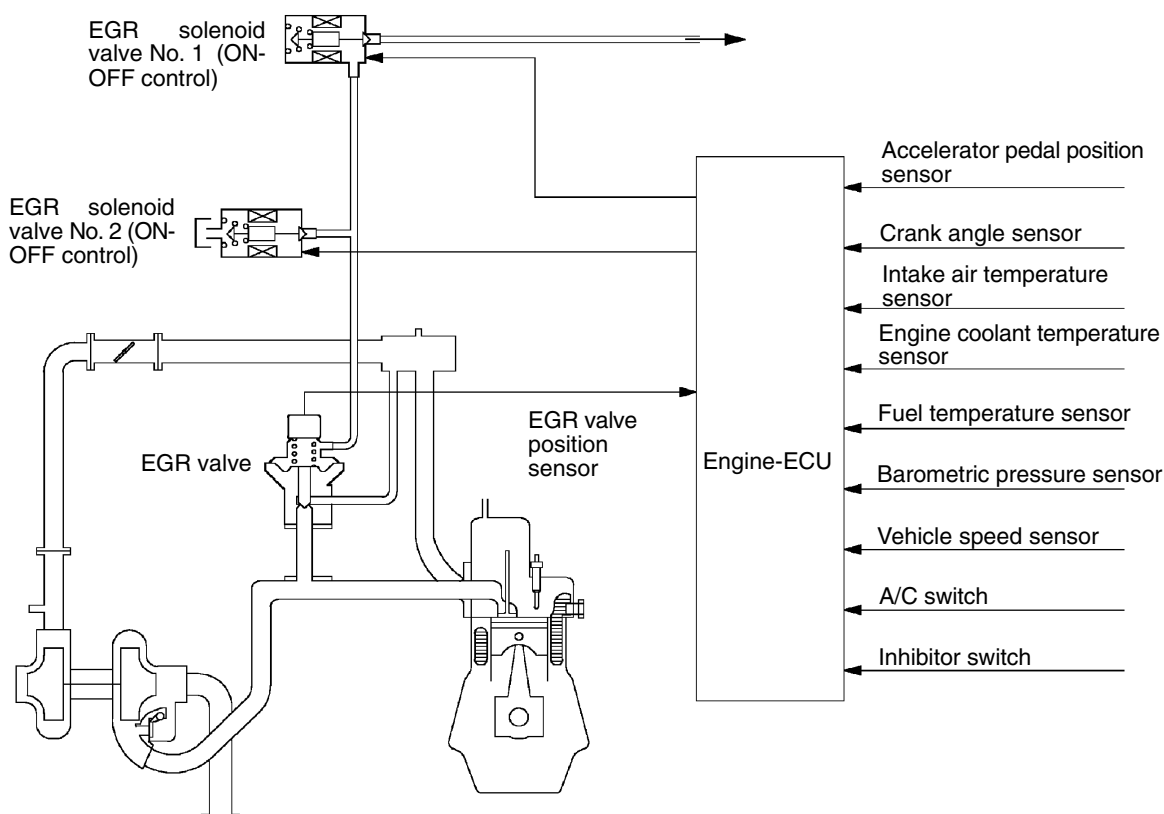

16005AA

COMPONENT LOCATION

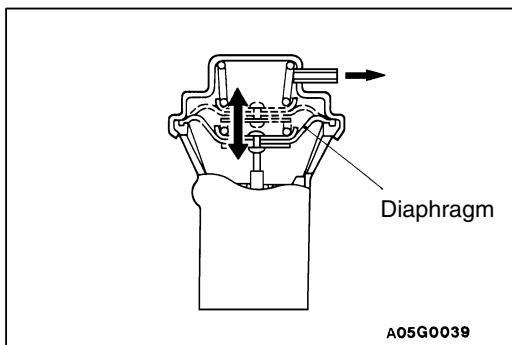
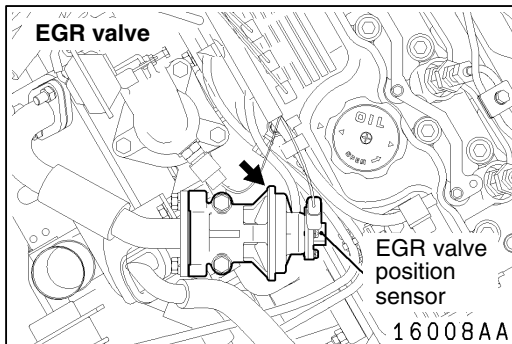
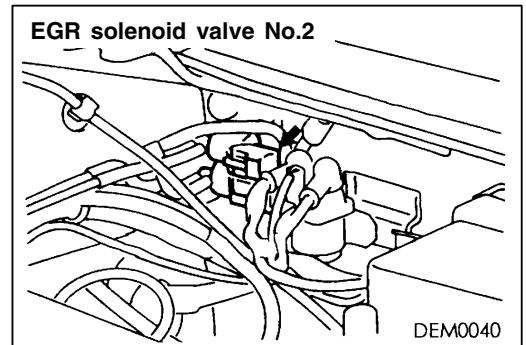
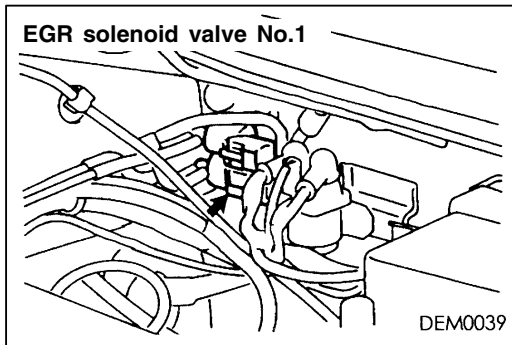

FUNCTION CHECK

1. Start the engine and warm it up until the engine coolant temperature reaches 65°C or above.
2. Race the engine by suddenly depressing the accelerator pedal, then check that the EGR valve diaphragm lifts.

EGR SOLENOID VALVE OPERATION CHECK

1. Remove EGR solenoid valve Nos.1 and 2 connectors and vacuum hoses.
2. Attach a vacuum pump to each nipple of the EGR solenoid valve Nos. 1 and 2. Then connect the each connector of EGR solenoid valve to battery and apply negative pressure. Check that the valves are airtight both when voltage is applied to each terminal of the EGR solenoid valve Nos.1 and 2 and when it is not applied.

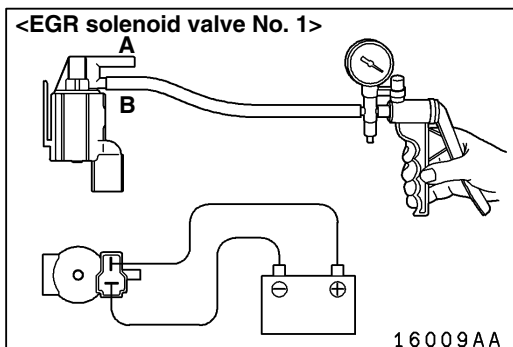

EGR solenoid valve No. 1

Battery voltage	Normal condition
When current is flowing	Vacuum leaks (Vacuum is maintained when nipple B is plugged).
When current is not flowing	Vacuum is maintained.

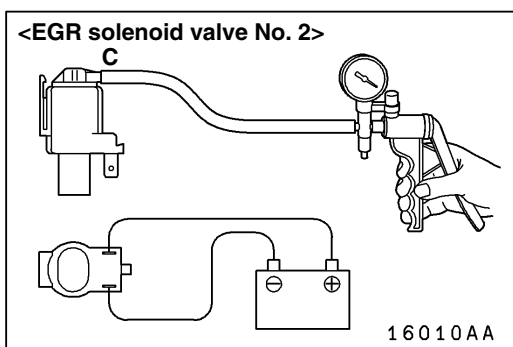

EGR solenoid valve No. 2

Battery voltage	Normal condition
When current is flowing	Vacuum is maintained.
When current is not flowing	Vacuum leaks.

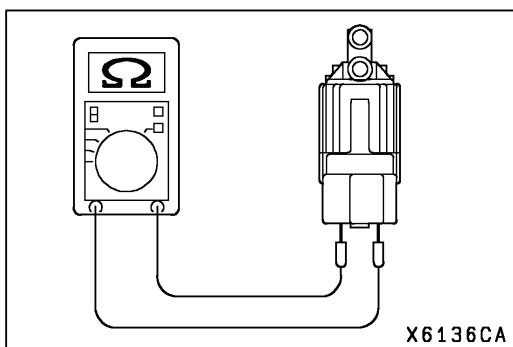

EGR SOLENOID VALVE RESISTANCE CHECK

Measure terminal resistance of EGR solenoid valves Nos. 1 and 2 with a circuit tester.

Standard value: 36 – 44 Ω (at 20°C)

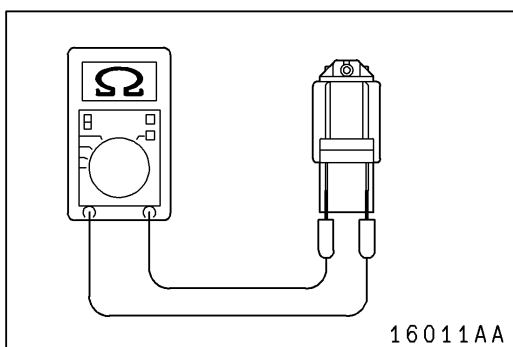

ACCELERATOR PEDAL POSITION SENSOR (APS), ENGINE COOLANT TEMPERATURE SENSOR, BOOST AIR TEMPERATURE SENSOR, FUEL TEMPERATURE SENSOR, EGR VALVE POSITION SENSOR CHECK

Refer to GROUP 13I – On-vehicle Service.

CHECK AT THE ENGINE-ECU TERMINALS

Refer to GROUP 13I – Troubleshooting.

EGR VALVE, EGR COOLER <4D56-Step III>

REMOVAL AND INSTALLATION

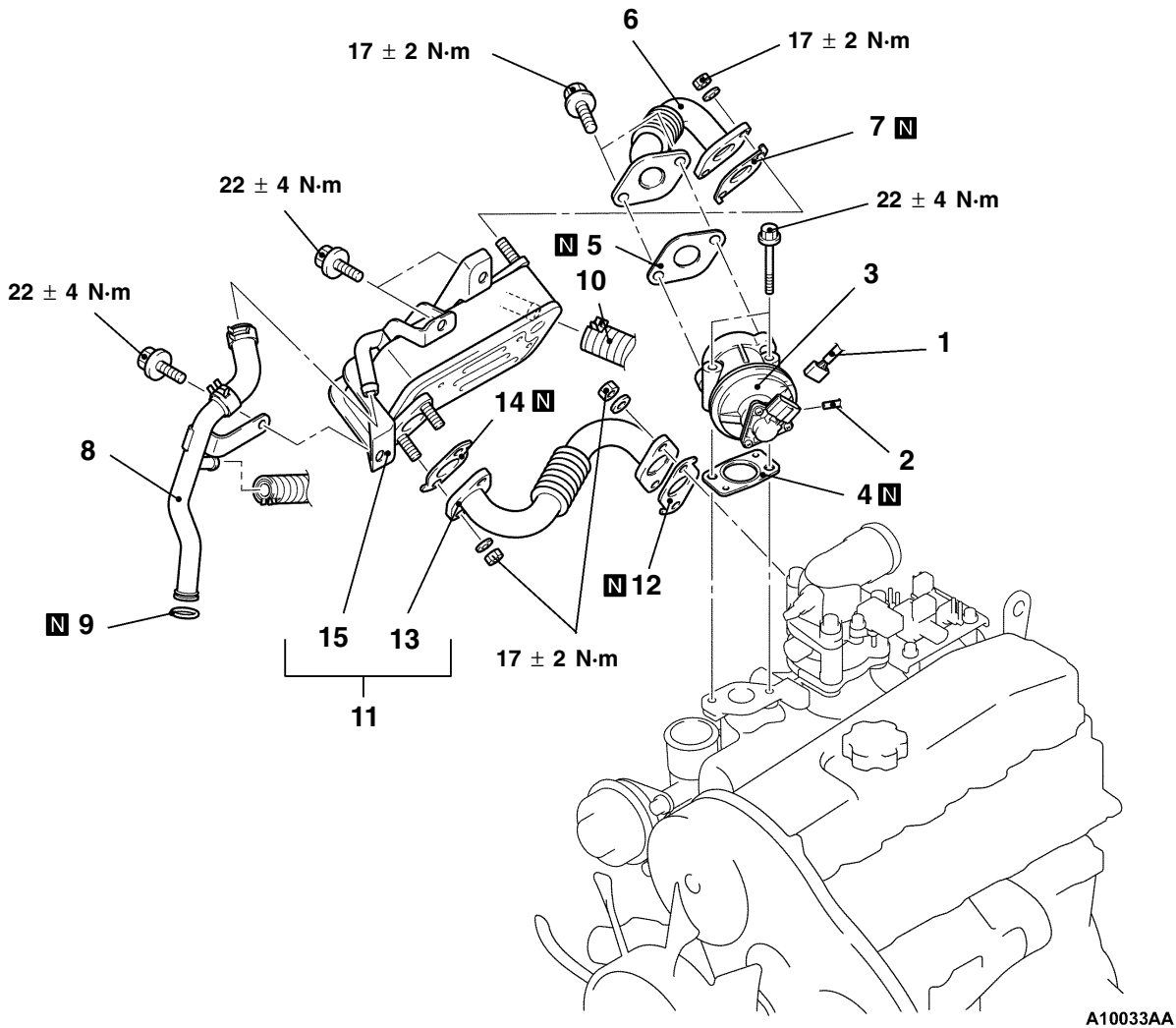

A10033AA

Removal steps

- | | | |
|--------------------|--|---|
| <p>▶A◀
▶C◀</p> | <ol style="list-style-type: none"> 1. EGR valve connector 2. Vacuum hose connection 3. EGR valve 4. EGR gasket 5. EGR pipe gasket 6. EGR upper pipe 7. EGR pipe gasket 8. Water pipe and hose assembly | <p>▶B◀</p> <ol style="list-style-type: none"> 9. O-ring 10. Water hose connection 11. EGR cooler and EGR lower pipe assembly <p>▶A◀</p> <ol style="list-style-type: none"> 12. EGR pipe gasket 13. EGR lower pipe 14. EGR pipe gasket 15. EGR cooler |
|--------------------|--|---|

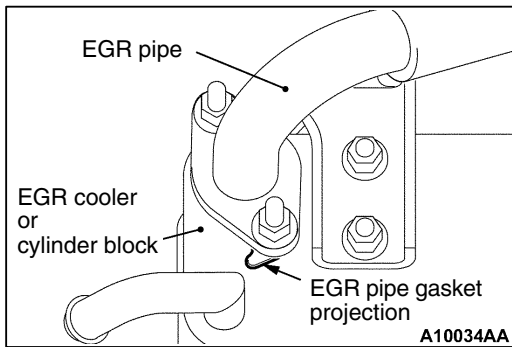
**INSTALLATION SERVICE POINT****▶A◀ EGR PIPE GASKET INSTALLATION**

Make sure that the projection of the EGR pipe gasket is installed in the location shown.

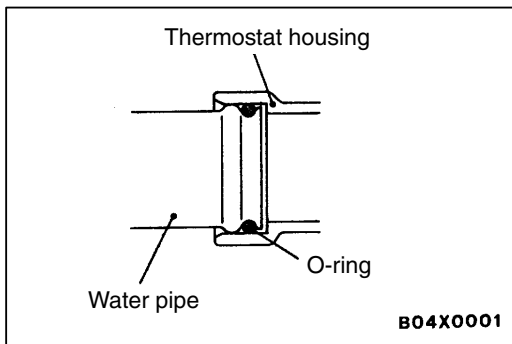
**▶B◀ O-RING INSTALLATION**

Rinse the mounting location of the O-ring and water pipe with water, and install the O-ring and water pipe.

Caution

1. Care must be taken not to permit engine oil or other greases to adhere to the O-ring.
2. When inserting the pipe, check to be sure that there is no sand, dirt, etc. on its inner surface.

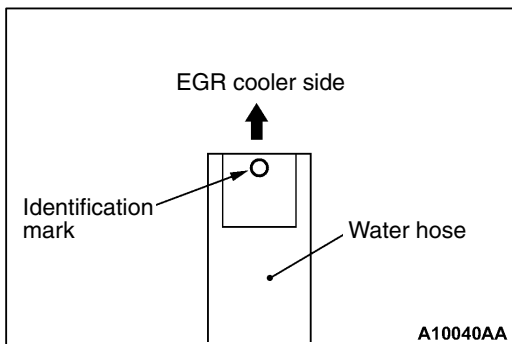
**▶C◀ WATER PIPE AND HOSE ASSEMBLY INSTALLATION**

When the water hose is separated from the water pipe, reconnect the water hose so that its identification mark faces toward the EGR cooler.

NOTES