

AUTOMATIC TRANSMISSION

R4AW3, V4AW3

CONTENTS

GENERAL INFORMATION	23B- 0-3
1. SPECIFICATIONS	23B- 1-1
TRANSMISSION MODEL TABLE	23B- 1-1
GEAR RATIO TABLE	23B-1-2d
SERVICE SPECIFICATIONS	23B- 1-3
VALVE BODY SPRING IDENTIFICATION	23B- 1-5
ACCUMULATOR PISTON SPRING IDENTIFICATION	23B- 1-6
ADJUSTMENT SNAP RINGS AND SPACERS	23B-1-6b
TORQUE SPECIFICATIONS	23B- 1-8
SEALANTS	23B- 1-9
2. SPECIAL TOOLS	23B- 2-1
3. TRANSMISSION AND TRANSFER	23B- 3-1
4. TRANSMISSION	23B- 4-1
5. OIL PUMP	23B- 5-1
6. OVERDRIVE PLANETARY GEAR AND OVERDRIVE DIRECT CLUTCH	23B- 6-1
7. OVERDRIVE SUPPORT	23B- 7-1
8. DIRECT CLUTCH	23B- 8-1
9. FORWARD CLUTCH	23B- 9-1
10. FRONT PLANETARY GEAR	23B-10-1
11. PLANETARY SUN GEAR AND ONEWAY CLUTCH No.1	23B-11-1
12. SECOND BRAKE	23B-12-1
13. REAR PLANETARY GEAR, OUTPUT SHAFT AND FIRST & REVERSE BRAKE	23B-13-1
14. SECOND COAST BRAKE PISTON	23B-14-1
15. VALVE BODY	23B-15-1
16. UPPER VALVE BODY	23B-16-1
17. LOWER VALVE BODY	23B-17-1
18. TRANSFER	23B-18-1
19. TRANSFER CASE PLATE	23B-19-1
20. TRANSFER INPUT GEAR	23B-20-1
21. COUNTER SHAFT GAER	23B-21-1
22. 2-4WD SYNCHRONIZER	23B-22-1
23. CENTER DIFFERENTIAL CASE	23B-23-1
24. REAR OUTPUT SHAFT	23B-24-1
25. TRANSFER DRIVE SHAFT	23B-25-1
26. FRONT OUTPUT SHAFT	23B-26-1
27. SPEEDOMETER GEAR	23B-27-1

REMARKS

This manual covers two models of automatic transmissions, R4AW3 and V4AW3.

When using this manual, please note that model designations "V4AW3" or "R4AW3, V4AW3" appearing in the headline of each page do not necessarily indicate applicability of the instruction included in the page.

You are requested to follow appropriate instructions according to the applicability indications included in text.

GENERAL INFORMATION

Precautions to be taken when disassembling and reassembling the transmission

- Because the automatic transmission is composed of component parts of an especially high degree of precision, these parts should be very carefully handled during disassembly and assembly so as not to scar or scratch them.
- A rubber mat should be placed on the workbench, and it should always be kept clean.
- During disassembly, cloth gloves or shop towels should not be used. If such items must be used, either use articles made of nylon, or use paper towels.
- All disassembled parts must be thoroughly cleaned.
Metal parts may be cleaned with ordinary detergents, but must be thoroughly air dried.
- Clean the clutch disc, resin thrust plate and rubber parts by using ATF (automatic transmission fluid), being very careful that dust, dirt, etc. do not adhere to them.
- Do not reuse gaskets, oil seals, or rubber parts.
Replace such parts with new ones at every reassembly. The O-ring of the oil level gauge need not be replaced.
- Do not use grease other than petrolatum jelly.
- Apply ATF to friction components, rotating parts, and sliding parts before installation.
- Do not apply sealer or adhesive to gaskets.
- When a bushing must be replaced, replace the assembly in which it is incorporated.
- If the transmission main unit is damaged, also disassemble and clean the cooler system.

MODEL R4AW3

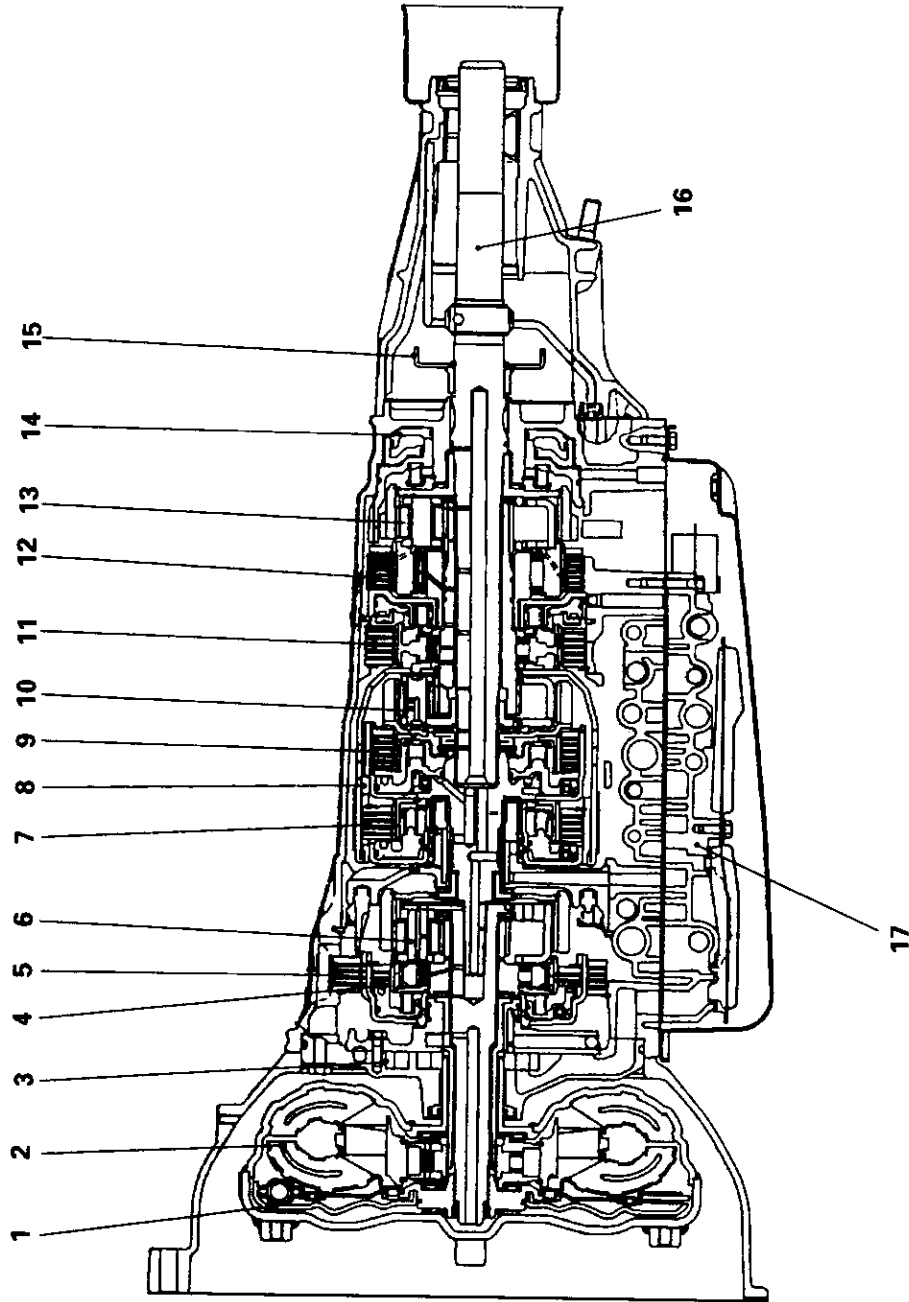

TRA0801

- | | | |
|--|---|--|
| <ul style="list-style-type: none"> 1. Lock-up clutch 2. Torque converter 3. Oil pump 4. Overdrive direct clutch 5. Overdrive brake 6. Overdrive planetary gear | <ul style="list-style-type: none"> 7. Forward clutch 8. Direct clutch 9. Second coast brake 10. Second brake 11. First & reverse brake 12. Front planetary gear | <ul style="list-style-type: none"> 13. Rear planetary gear 14. First and reverse brake piston 15. AT speed sensor rotor 16. Output shaft 17. Valve body |
|--|---|--|

MODEL V4AW3 — FOUR SPEED FOUR WHEEL DRIVE TRANSMISSION WITH LOCK-UP CLUTCH and VISCOUS COUPLING

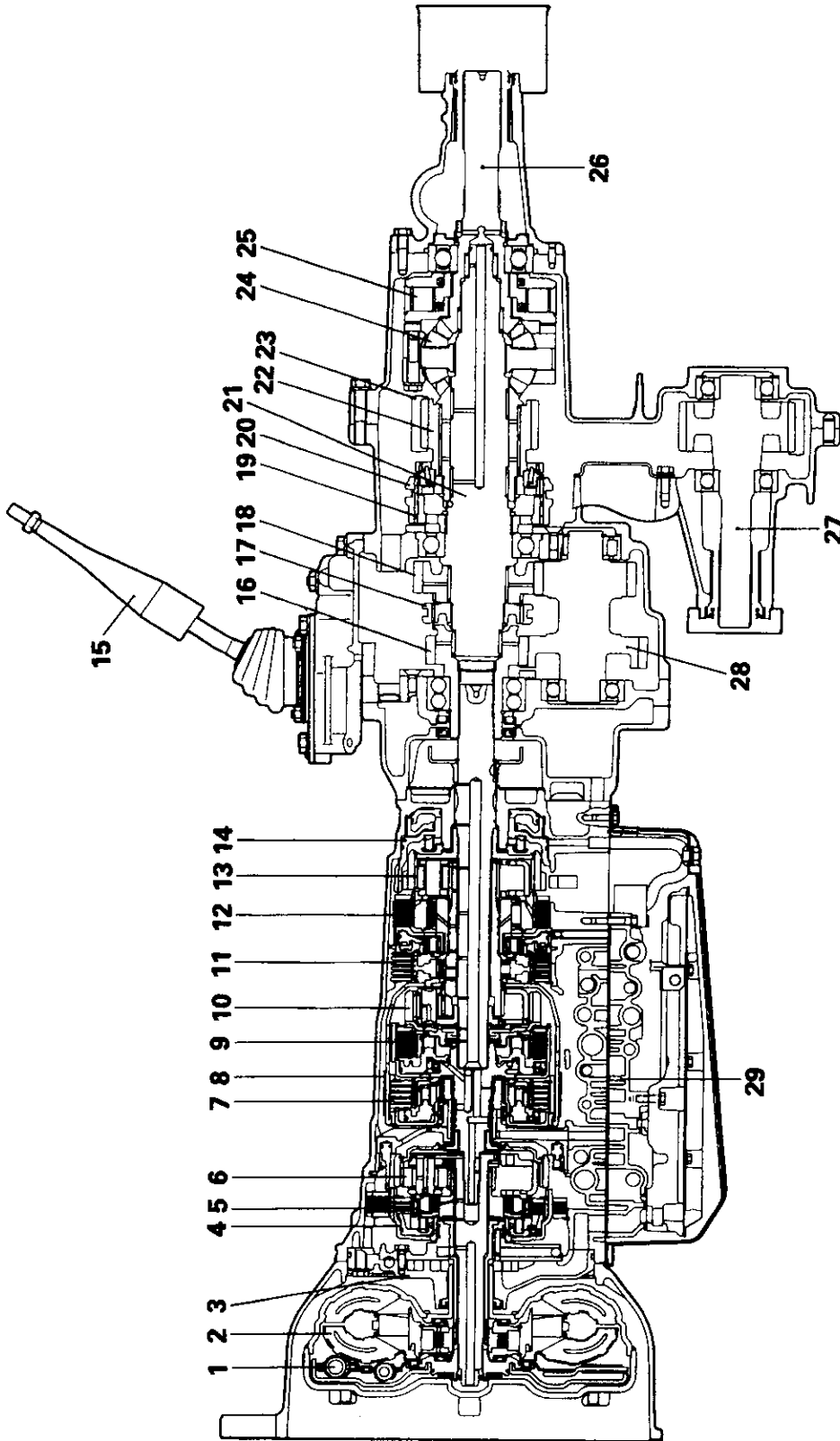

9RA0085

- | | | |
|--|---|---|
| <ul style="list-style-type: none"> 1. Torque converter clutch 2. Torque converter 3. Oil pump 4. Overdrive clutch 5. Overdrive brake 6. Overdrive planetary gear 7. Direct clutch 8. Second coast brake 9. Forward clutch 10. Front planetary gear | <ul style="list-style-type: none"> 11. Second brake 12. First & reverse brake 13. Rear planetary gear 14. First & reverse brake piston 15. Transfer control lever 16. Input gear 17. High-low clutch 18. Low speed gear 19. Differential lock hub 20. 2-4WD synchronizer sleeve | <ul style="list-style-type: none"> 21. Transfer drive shaft 22. Drive sprocket 23. Chain 24. Center differential 25. Viscous coupling 26. Rear output shaft 27. Front output shaft 28. Counter gear 29. Valve body |
|--|---|---|

HYDRAULIC CONTROL SYSTEM

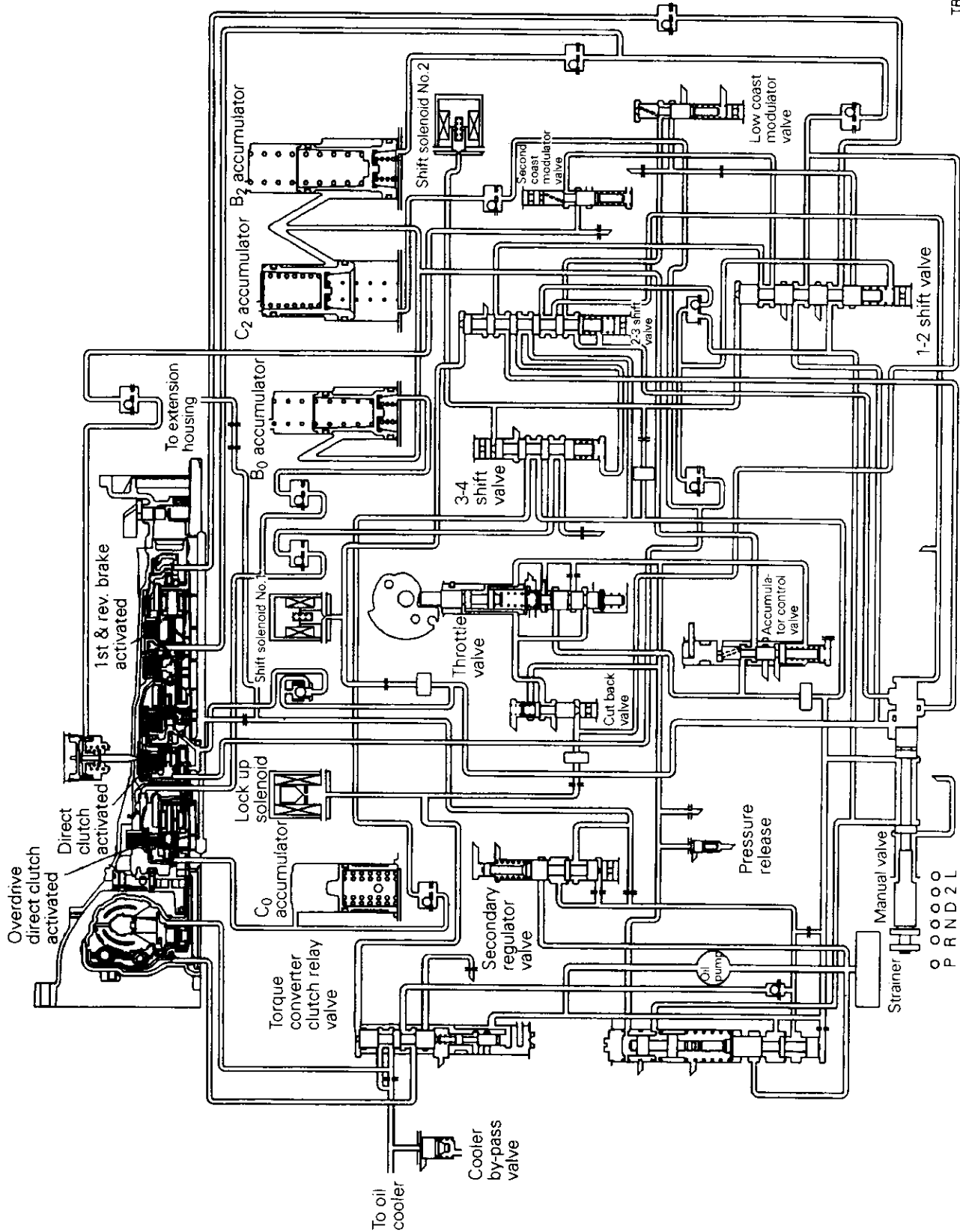

TRA0735

Q O O O O
P R N D L

1. SPECIFICATIONS

TRANSMISSION MODEL TABLE — MODEL 1993

Transmission model	Gear ratio	Torque converter clutch	VCU	Speedometer gear ratio	Vehicle model	Engine model
EC V4AW3-7-UI	A	×	×	29/9	V46W	4M40 with turbocharger and intercooler
V4AW3-7-UIL	A	×	×	29/9	V46W	4M40 with turbocharger and intercooler
V4AW3-7-UJ	A	×	×	30/9	V46W	4M40 with turbocharger and intercooler
V4AW3-7-UJL	A	×	×	30/9	V46W	4M40 with turbocharger and intercooler
V4AW3-7-MH	B	×	×	28/9	V25W, V45W	6G74
V4AW3-7-MHL	B	×	×	28/9	V25W, V45W	6G74
EXP V4AW3-7-UI	A	×	×	29/9	V46W	4M40 with turbocharger and intercooler
V4AW3-7-UIL	A	×	×	29/9	V46W	4M40 with turbocharger and intercooler
V4AW3-7-MH	B	×	×	28/9	V45W	6G74
V4AW3-7-MHL	B	×	×	28/9	V25W, V45W	6G74
AUS V4AW3-7-MH	B	×	×	28/9	V45W	6G74

TRANSMISSION MODEL TABLE — MODEL 1994

Transmission model	Gear ratio	Torque converter clutch	VCU	Speedometer gear ratio	Vehicle model	Engine model
EC V4AW3-7-UI	A	×	×	29/9	V46W	4M40 with turbocharger and intercooler
V4AW3-7-UIL	A	×	×	29/9	V46W	4M40 with turbocharger and intercooler
V4AW3-7-UJ	A	×	×	30/9	V46W	4M40 with turbocharger and intercooler
V4AW3-7-UJL	A	×	×	30/9	V46W	4M40 with turbocharger and intercooler
V4AW3-7-MH	B	×	×	28/9	V25W, V45W	6G74
V4AW3-7-MHL	B	×	×	28/9	V25W, V45W	6G74
EXP V4AW3-7-UI	A	×	×	29/9	V46W	4M40 with turbocharger and intercooler
V4AW3-7-UIL	A	×	×	29/9	V46W	4M40 with turbocharger and intercooler
V4AW3-7-SJL	A	×	×	30/9	V46W	4M40 with turbocharger and intercooler
V4AW3-7-SKL	A	×	×	31/9	V46W	4M40 with turbocharger and intercooler
V4AW3-7-MG	B	×	×	27/9	V45W	6G74
V4AW3-7-MGL	B	×	×	27/9	V25W, V45W	6G74
V4AW3-7-MH	B	×	×	28/9	V45W	6G74
V4AW3-7-MHL	B	×	×	28/9	V25W, V45W	6G74
AUS V4AW3-7-MH	B	×	×	28/9	V45W	6G74

TRANSMISSION MODEL TABLE — MODEL 1995

Transmission model	Gear ratio	Torque converter clutch	VCU	Speedometer gear ratio	Vehicle model	Engine model
EC V4AW3-7-UI	A	×	×	29/9	V46W	4M40 with turbocharger and intercooler
V4AW3-7-UIL	A	×	×	29/9	V46W	4M40 with turbocharger and intercooler
V4AW3-7-UJ	A	×	×	30/9	V46W	4M40 with turbocharger and intercooler
V4AW3-7-UJL	A	×	×	30/9	V46W	4M40 with turbocharger and intercooler
V4AW3-7-LI	B	×	×	29/9	V23W, V43W	6G72
V4AW3-7-LIL	B	×	×	29/9	V23W, V43W	6G72
V4AW3-7-MH	B	×	×	28/9	V25W, V45W	6G74
V4AW3-7-MHL	B	×	×	28/9	V25W, V45W	6G74
EXP V4AW3-7-UI	A	×	×	29/9	V46W	4M40 with turbocharger and intercooler
V4AW3-7-UIL	A	×	×	29/9	V46W	4M40 with turbocharger and intercooler
V4AW3-7-MG	B	×	×	27/9	V45W	6G74
V4AW3-7-MGL	B	×	×	27/9	V25W, V45W	6G74
V4AW3-7-MH	B	×	×	28/9	V45W	6G74
V4AW3-7-MHL	B	×	×	28/9	V25W, V45W	6G74
AUS R4AW3-5-LE	C	×	—	19/9	PB6W	6G72

TRANSMISSION MODEL TABLE — MODEL 1996

Transmission model	Gear ratio	Torque converter clutch	VCU	Speedometer gear ratio	Vehicle model	Engine model
EC V4AW3-7-LIA	B	×	×	29/9	V23W, V23C, V43W	6G72
V4AW3-7-LILA	B	×	×	29/9	V23W, V23C, V43W	6G72
V4AW3-7-MH	B	×	×	28/9	V45W	6G74
V4AW3-7-MHA	B	×	×	28/9	V24W	6G74
V4AW3-7-MHL	B	×	×	28/9	V45W	6G74
V4AW3-7-MHLA	B	×	×	28/9	V24W	6G74
V4AW3-7-UI	A	×	×	29/9	V46W	4M40 with turbocharger and intercooler
V4AW3-7-UIL	A	×	×	29/9	V46W	4M40 with turbocharger and intercooler
V4AW3-7-UJ	A	×	×	30/9	V46W	4M40 with turbocharger and intercooler
EXP V4AW3-7-MGA	B	×	×	27/9	V45W	6G74
V4AW3-7-MGLA	B	×	×	27/9	V25W, V45W	6G74
V4AW3-7-MHA	B	×	×	28/9	V45W	6G74
V4AW3-7-MHLA	B	×	×	28/9	V25W, V45W	6G74
V4AW3-7-UI	A	×	×	29/9	V46W	4M40 with turbocharger and intercooler
V4AW3-7-UIL	A	×	×	29/9	V46W	4M40 with turbocharger and intercooler
AUS R4AW3-5-LF	C	×	—	19/9	PB6W	6G72
V4AW3-7-MHA	B	×	×	28/9	V45W	6G74

TRANSMISSION MODEL TABLE — MODEL 1997

Transmission model	Gear ratio	Torque converter clutch	VCU	Speedometer gear ratio	Vehicle model	Engine model
EC V4AW3-7-LHA	B	×	×	28/9	V23C, V23W	6G72
V4AW3-7-LHLA	B	×	×	28/9	V23C, V23W	6G72
V4AW3-7-LIA	B	×	×	29/9	V43W	6G72
V4AW3-7-LILA	B	×	×	29/9	V43W	6G72
V4AW3-7-MFA	B	×	×	26/9	V25W, V45W	6G74
V4AW3-7-MFLA	B	×	×	26/9	V25W, V45W	6G74
V4AW3-7-UI	A	×	×	29/9	V46W	4M40 with turbocharger and intercooler
V4AW3-7-UIL	A	×	×	29/9	V46W	4M40 with turbocharger and intercooler
V4AW3-7-UJ	A	×	×	30/9	V46W	4M40 with turbocharger and intercooler
EXP V4AW3-7-MGA	B	×	×	27/9	V45W	6G74
V4AW3-7-MGLA	B	×	×	27/9	V25W, V45W	6G74
V4AW3-7-MHA	B	×	×	28/9	V45W	6G74
V4AW3-7-MHLA	B	×	×	28/9	V25W, V45W	6G74
V4AW3-7-UI	A	×	×	29/9	V46W	4M40 with turbocharger and intercooler
V4AW3-7-UIL	A	×	×	29/9	V46W	4M40 with turbocharger and intercooler
AUS R4AW3-5-LEC	B	×	×	25/9	PB6W	6G72
V4AW3-6-LIT	B	×	×	29/9	K76T	6G72
V4AW3-7-MGA	B	×	×	27/9	V45W	6G74
V4AW3-7-MIA	B	×	×	29/9	V45W	6G74

TRANSMISSION MODEL TABLE — MODEL 1998

Transmission model	Gear ratio	Torque converter clutch	VCU	Speedometer gear ratio	Vehicle model	Engine model
EC V4AW3-B-LHA	B	×	×	28/9	V23C, V23W	6G72
V4AW3-B-LHLA	B	×	×	28/9	V23C, V23W	6G72
V4AW3-B-LIA	B	×	×	29/9	V43W	6G72
V4AW3-B-LILA	B	×	×	29/9	V43W	6G72
V4AW3-B-NFA	B	×	×	26/9	V25W, V45W	6G74
V4AW3-B-NFLA	B	×	×	26/9	V25W, V45W	6G74
V4AW3-B-UI	A	×	×	29/9	V46W	4M40 with turbocharger and intercooler
V4AW3-B-UIL	A	×	×	29/9	V46W	4M40 with turbocharger and intercooler
V4AW3-B-UJ	A	×	×	30/9	V46W	4M40 with turbocharger and intercooler
EXP V4AW3-B-MGA	B	×	×	27/9	V45W	6G74
V4AW3-B-MGLA	B	×	×	27/9	V25W, V45W	6G74
V4AW3-B-MHA	B	×	×	28/9	V45W	6G74
V4AW3-B-MHLA	B	×	×	28/9	V25W, V45W	6G74
V4AW3-B-UI	A	×	×	29/9	V46W	4M40 with turbocharger and intercooler
V4AW3-B-UIL	A	×	×	29/9	V46W	4M40 with turbocharger and intercooler
AUS R4AW3-5-LEC	B	×	×	25/9	PB6W	6G72
V4AW3-6-LIT	B	×	×	29/9	K76T	6G72
V4AW3-7-MGA	B	×	×	27/9	V45W	6G74
V4AW3-7-MIA	B	×	×	29/9	V45W	6G74

TRANSMISSION MODEL TABLE — MODEL 1999

Transmission model	Gear ratio	Torque converter clutch	VCU	Speedometer gear ratio	Vehicle model	Engine model
EC V4AW3-B-LHLA	B	×	×	28/9	V23C, V23W	6G72
V4AW3-B-LHA	B	×	×	28/9	V23C, V23W	6G72
V4AW3-7-LILA	B	×	×	29/9	V43W	6G72
V4AW3-B-LIA	B	×	×	29/9	V43W	6G72
V4AW3-B-NFLA	B	×	×	26/9	V25W, V45W	6G74
V4AW3-B-NFA	B	×	×	26/9	V25W, V45W	6G74
V4AW3-B-UI	A	×	×	29/9	V46W	4M40 with turbocharger and intercooler
V4AW3-B-UIL	A	×	×	29/9	V46W	4M40 with turbocharger and intercooler
V4AW3-B-UJ	A	×	×	30/9	V46W	4M40 with turbocharger and intercooler
EXP V4AW3-7-LILA	B	×	×	29/9	V43W	6G72
V4AW3-B-LIA	B	×	×	29/9	V43W	6G72
V4AW3-B-MGA	B	×	×	27/9	V45W	6G74
V4AW3-B-MGLA	B	×	×	27/9	V25W, V45W	6G74
V4AW3-B-NGLA	B	×	×	27/9	V45W	6G74
V4AW3-B-UIL	A	×	×	29/9	V46W	4M40 with turbocharger and intercooler
V4AW3-B-UI	A	×	×	29/9	V46W	4M40 with turbocharger and intercooler
AUS V4AW3-6-LHGF	B	×	×	28/9	K96W	6G72
V4AW3-6-LIT	B	×	×	29/9	K76T	6G72
V4AW3-B-NGA	B	×	×	27/9	V25W, V45W	6G74
V4AW3-B-NIA	B	×	×	29/9	V45W	6G74

TRANSMISSION MODEL TABLE — MODEL 2000

Transmission model	Gear ratio	Torque converter clutch	VCU	Speedometer gear ratio	Vehicle model	Engine model
EC V4AW3-B-LHLA	B	×	×	28/9	V23C, V23W	6G72
V4AW3-B-LHA	B	×	×	28/9	V23C, V23W	6G72
V4AW3-7-LILA	B	×	×	29/9	V43W	6G72
V4AW3-B-LIA	B	×	×	29/9	V43W	6G72
V4AW3-B-NFLA	B	×	×	26/9	V25W, V45W	6G74
V4AW3-B-NFA	B	×	×	26/9	V25W, V45W	6G74
V4AW3-B-UI	A	×	×	29/9	V46W	4M40 with turbocharger and intercooler
V4AW3-B-UIL	A	×	×	29/9	V46W	4M40 with turbocharger and intercooler
V4AW3-B-UJ	A	×	×	30/9	V46W	4M40 with turbocharger and intercooler
V4AW3-B-UJL	A	×	×	30/9	V46W	4M40 with turbocharger and intercooler
EXP V4AW3-7-LILA	B	×	×	29/9	V43W	6G72
V4AW3-B-LIA	B	×	×	29/9	V43W	6G72
V4AW3-B-MGA	B	×	×	27/9	V45W	6G74
V4AW3-B-MGLA	B	×	×	27/9	V25W, V45W	6G74
V4AW3-B-NGLA	B	×	×	27/9	V45W	6G74
V4AW3-B-UIL	A	×	×	29/9	V46W	4M40 with turbocharger and intercooler
V4AW3-B-UI	A	×	×	29/9	V46W	4M40 with turbocharger and intercooler
AUS V4AW3-6-LHGF	B	×	×	28/9	K96W	6G72
V4AW3-6-LIT	B	×	×	29/9	K76T	6G72
V4AW3-B-NGA	B	×	×	27/9	V25W, V45W	6G74
V4AW3-B-NIA	B	×	×	29/9	V45W	6G74

GEAR RATIO TABLE

Gear ratio		A	B	C
Transmission	1st	2.804	2.804	2.804
	2nd	1.531	1.531	1.531
	3rd	1.000	1.000	1.000
	4th	0.705	0.754	0.754
	Reverse	2.393	2.393	2.393
Transfer	High	1.000	1.000	—
	Low	1.900	1.900	—

SERVICE SPECIFICATIONS

mm (in.)

	Standard	Limit
Transmission		
Clearance between second brake drum and plate	4M40, 6G72 0.6 – 1.12 (0.024 – 0.044)	
	6G74 0.7 – 1.22 (0.028 – 0.048)	
Clearance between snap ring and flange	0.62 – 1.98 (0.024 – 0.078)	
Second brake piston stroke	1.5 – 3.0 (0.059 – 0.118)	
Output shaft end play	0.27 – 0.86 (0.011 – 0.034)	
Torque converter housing clearance	31.1 or more (1.22 or more)	
Oil pump body clearance	0.07 – 0.15 (0.003 – 0.006)	0.30 (0.012)
Oil pump tip clearance	0.11 – 0.14 (0.004 – 0.006)	0.30 (0.012)
Oil pump side clearance	0.02 – 0.05 (0.0008 – 0.0020)	0.30 (0.012)
Overdrive direct clutch disc thickness		1.84 (0.072)
Overdrive direct clutch return spring free length	Approx. 15.8 (Approx. 0.62)	
Overdrive direct piston stroke	1.85 – 2.15 (0.073 – 0.085)	
Overdrive support assembly return spring free length	Approx. 18.6 (Approx. 0.73)	
Direct clutch disc thickness		1.84 (0.072)
Direct clutch return spring free length	Approx. 19.8 (Approx. 0.78)	
Direct clutch piston stroke	1.37 – 1.67 (0.054 – 0.066)	
Forward clutch disc thickness		1.84 (0.072)
Forward clutch return spring free length	Approx. 11.55 (Approx. 0.45)	
Forward clutch piston stroke	4M40, 6G72 2.65 – 3.98 (1.104 – 0.157)	
	6G74 2.90 – 4.29 (0.114 – 0.169)	
Second brake assembly return spring free length	Approx. 15.05 (Approx. 0.59)	
First & reverse brake disc thickness		1.51 (0.059)
First & reverse brake return spring free length	Approx. 13.09 (Approx. 0.52)	
Oil pump body busing ID		38.18 (1.503)
Oil pump stator shaft bushing ID (Front)		21.57 (0.849)
(Rear)		27.07 (1.066)

		mm (in.)
	Standard	Limit
Overdrive direct clutch drum bushing ID		27.11 (1.067)
Overdrive planetary gear bushing ID		11.27 (0.444)
Direct clutch drum bushing ID		53.97 (2.125)
Forward clutch drum bushing ID		24.07 (0.948)
Front planetary ring gear bushing ID		24.07 (0.948)
Planetary sun gear bushing ID		24.07 (0.948)
Transfer		
H-L clutch hub end play	0 – 0.08 (0 – 0.0031)	
Input gear bearing end play	0 – 0.06 (0 – 0.0024)	
Center differential end play	0.025 – 0.150 (0.00098 – 0.00591)	
Differential lock hub end play	0 – 0.08 (0 – 0.0031)	
2-4WD synchronizer hub end play	0 – 0.08 (0 – 0.0031)	
Rear output shaft bearing end play	0 – 0.08 (0 – 0.0031)	
Countershaft gear end play	0 – 0.15 (0 – 0.0059)	
Countershaft gear bearing end play	0 – 0.08 (0 – 0.0031)	
Clearance between outer synchronizer ring back side and drive sprocket		0.3 (0.0118)

VALVE BODY SPRING IDENTIFICATION

mm (in.)

	Free height	Outside diameter	Number of loops	Wire diameter
Lower valve body				
1-2 shift valve spring	30.8 (1.213)	9.7 (0.381)	8.5	0.9 (0.035)
Primary regulator valve spring	62.3 (2.453)	18.6 (0.732)	12.5	1.7 (0.067)
<Except V4AW3-B-U>				
<V4AW3-B-U only>	66.7 (2.626)	17.6 (0.693)	10.5	1.6 (0.063)
Accumulator control valve spring	33.9 (1.335)	8.8 (0.346)	10.0	0.8 (0.031)
<Except V4AW3-B-N, U>				
<V4AW3-B-N, U only>	29.8 (1.173)	8.8 (0.346)	16.0	0.8 (0.031)
Check valve spring	17.53 (0.690)	12.1 (0.476)	3.2	1.1 (0.043)
Relief valve spring	11.2 (0.441)	6.4 (0.252)	7.5	0.9 (0.035)
Upper valve body				
Downshift valve	27.3 (1.075)	8.7 (0.343)	10.5	1.0 (0.039)
Throttle valve	20.6 (0.811)	9.2 (0.362)	7.5	0.7 (0.028)
3-4 shift valve	30.8 (1.213)	9.7 (0.381)	8.5	0.9 (0.035)
Second coast modulator valve	30.9 (1.217)	8.6 (0.339)	9.5	1.1 (0.043)
<Except V4AW3-B-U>				
<V4AW3-B-U only>	29.6 (1.165)	8.3 (0.327)	10.5	1.0 (0.039)
Lock-up relay valve	21.4 (0.843)	5.5 (0.217)	15.5	0.6 (0.024)
Secondary regulator valve	30.9 (1.217)	11.2 (0.441)	8.5	1.5 (0.059)
Cut back valve	21.8 (0.858)	6.0 (0.236)	11.5	0.6 (0.024)
2-3 shift valve	30.8 (1.213)	9.7 (0.381)	8.5	0.9 (0.035)
Low coast modulator valve	30.4 (1.197)	8.3 (0.327)	8.5	0.8 (0.031)

ACCUMULATOR PISTON SPRING IDENTIFICATION

				mm (in.)		
		Free height	Outside diameter	Number of loops	Wire diameter	
C ₀ :	Outer spring 1	74.6 (2.937)	20.9 (0.823)	12.3	2.3 (0.091)	
	Outer spring 2	46.10 (1.811)	14.0 (0.551)	12.5	2.2 (0.087)	
C ₂ :	Outer spring	4M40 <Except 98– model PAJERO/MONTERO>	22.0 (0.866)	11.9 (0.469)	5.3	1.7 (0.067)
		6G72 <PAJERO/MONTERO, L200>	24.0 (0.945)	12.0 (0.472)	5.4	1.7 (0.067)
		6G72 <L400>	21.0 (0.827)	10.5 (0.413)	3.9	1.7 (0.067)
		6G74 <Except 98– model PAJERO/MONTERO>	20.0 (0.787)	12.1 (0.476)	4.5	1.7 (0.067)
		6G74, 4M40 <98– model PAJERO/MONTERO>	22.0 (0.866)	12.0 (0.472)	5.3	1.7 (0.067)
	Inner spring	4M40 <Except 98– model PAJERO/MONTERO>	64.0 (2.520)	20.2 (0.795)	10.3	2.2 (0.087)
		6G74 <Except 98– model PAJERO/MONTERO>	70.2 (2.764)	20.2 (0.795)	10.1	2.3 (0.091)
	Inner spring 1	4M40 <98– model PAJERO/MONTERO>	68.5 (2.697)	20.2 (0.795)	9.1	2.2 (0.087)
		6G72	64.0 (2.520)	20.2 (0.795)	10.3	2.2 (0.087)
		6G74 <98– model PAJERO/MONTERO>	64.0 (2.520)	20.2 (0.795)	12.3	2.2 (0.087)
Inner spring 2	6G72	42.1 (1.657)	14.7 (0.579)	9.25	2.5 (0.098)	
	6G74, 4M40 <98– model PAJERO/MONTERO>	42.1 (1.657)	14.7 (0.579)	7.3	2.5 (0.098)	
B ₀ :	Outer spring	14.5 (0.571)	13.0 (0.512)	3.0	2.1 (0.083)	
	Inner spring	62.0 (2.441)	16.0 (0.630)	11.9	2.1 (0.083)	
B ₂ :	Outer spring	4M40 <Except 98– model PAJERO/MONTERO>	17.0 (0.669)	12.7 (0.499)	3.3	2.1 (0.083)
		4M40 <98– model PAJERO/MONTERO>	20.0 (0.787)	14.0 (0.551)	5.2	1.9 (0.075)
		6G72	23.0 (0.901)	14.0 (0.551)	4.9	2.0 (0.079)
		6G74 <Except 98– model PAJERO/MONTERO>	22.0 (0.886)	14.0 (0.551)	5.2	1.9 (0.075)
		6G74 <98– model PAJERO/MONTERO>	19.0 (0.748)	14.0 (0.551)	5.7	2.0 (0.079)
	Inner spring	4M40 <Except 98– model PAJERO/MONTERO>	70.5 (2.776)	19.9 (0.783)	10.4	2.4 (0.094)
		4M40 <98– model PAJERO/MONTERO>	72.6 (2.858)	19.9 (0.783)	12.5	2.8 (0.110)
		6G72	70.5 (2.776)	19.7 (0.776)	12.9	2.7 (0.106)
		6G74 <Except 98– model PAJERO/MONTERO>	72.6 (2.858)	19.9 (0.783)	12.5	2.8 (0.110)
		6G74 <98– model PAJERO/MONTERO>	75.3 (2.964)	20.0 (0.787)	14.3	2.7 (0.106)

Intentionally blank

ADJUSTMENT SNAP RINGS AND SPACERS

Part name	Thickness mm (in.)	Identification symbol	Part No.
Transfer			
Snap ring (For adjustment of input gear bearing end play)	2.30 (0.091)	—	MD704199
	2.35 (0.093)	Red	MD704200
	2.40 (0.094)	White	MD704201
	2.45 (0.096)	Blue	MD704202
	2.50 (0.098)	Green	MD704203
Snap ring (For adjustment of H-L clutch hub end play)	2.18 (0.086)	Blue	MR110983
	2.25 (0.089)	—	MR110984
	2.32 (0.091)	Brown	MR110985
	2.39 (0.094)	White	MR110986
Snap ring (For adjustment of differential lock hub end play)	2.56 (0.101)	—	MD738386
	2.63 (0.104)	Red	MD738387
	2.70 (0.106)	White	MD738388
	2.77 (0.109)	Blue	MD738389
	2.84 (0.112)	Yellow	MD738390
	2.91 (0.115)	Green	MD738391
	2.98 (0.117)	Purple	MD738392
Snap ring (For adjustment of 2-4WD synchronizer hub end play)	2.56 (0.101)	—	MD738393
	2.63 (0.104)	Red	MD738394
	2.70 (0.106)	White	MD738395
	2.77 (0.109)	Blue	MD738396
	2.84 (0.112)	Yellow	MD738397
Snap ring (For adjustment of transfer counter gear bearing end play)	1.48 (0.058)	Blue	MB919176
	1.62 (0.064)	—	MB919177
Spacer (For adjustment of transfer counter gear end play)	1.77 (0.070)	—	MB896728
	1.91 (0.0752)	Blue	MB896729
	2.05 (0.0807)	Brown	MB896730
	2.19 (0.0862)	White	MB896731
	2.33 (0.0917)	Red	MB896732
Snap ring (For adjustment of rear output shaft bearing end play)	2.26 (0.089)	—	MD734311
	2.33 (0.092)	Red	MD734312
	2.40 (0.094)	White	MD734313
	2.47 (0.097)	Blue	MD734314

Part name	Thickness mm (in.)	Identification symbol	Part No.
Spacer (For adjustment of center differential end play)	0.84 (0.033)	84	MD734326
	0.93 (0.037)	93	MD734327
	1.02 (0.040)	02	MD734328
	1.11 (0.044)	11	MD734329
	1.20 (0.047)	20	MD734330
	1.29 (0.051)	29	MD734331
	1.38 (0.054)	38	MD734332
	1.47 (0.058)	47	MD734333
	1.56 (0.061)	56	MD734334
	1.65 (0.065)	65	MD734335
	1.74 (0.069)	74	MD734336
	1.83 (0.072)	83	MD734337
	1.92 (0.076)	92	MD734338
2.01 (0.079)	01	MD734339	

TORQUE SPECIFICATIONS

	Torque		
	Nm	kgm	ft.lbs.
Transmission			
Transmission case	36	3.6	26
Case adapter <4WD>	36	3.6	26
Extension housing <2WD>	29	2.9	21
Transmission control shaft lever	16	1.6	12
Parking lock rod	7	0.7	5
Speedometer driven gear <2WD>	16	1.6	12
A/T Speed sensor	16	1.6	12
O/D support mounting bolt	26	2.6	19
Oil pump	22	2.2	16
Throttle cable	6	0.6	4.3
Valve body mounting bolt	10	1.0	7.2
Transmission wire	6	0.6	4.3
Oil strainer	10	1.0	7.2
Oil screen <2WD>	6	0.6	4.3
Oil screen <4WD>	7	0.7	5
Oil pan	8	0.8	5.8
Drain plug	21	2.1	15
Oil temperature sensor	15	1.5	11
Converter housing			
10 mm (0.39 in.) diameter bolt	35	3.5	25
12 mm (0.47 in.) diameter bolt	58	5.8	42
Inhibitor switch			
bolt	13	1.3	9
nut	4	0.4	2.9
Oil pump stator	8	0.8	5.8
Valve body upper bolt	7	0.7	5
Manual detent spring	10	1.0	7.2
Throttle valve cam	10	1.0	7.2
Shift solenoid			
No.1	10	1.0	7.2
No.2	10	1.0	7.2
Lock up solenoid	10	1.0	7.2
Transfer			
Rear cover	19	1.9	14
Chain cover	36	3.6	26
Center differential case	65	6.5	47
Bearing retainer	19	1.9	14
Oil pool cover	9	0.9	6.5
Lock plate	19	1.9	14
Detection switch	36	3.6	26
Plug	36	3.6	26
Poppet plug	36	3.6	26
H-L shift rail plug	33	3.3	24

	Torque		
	Nm	kgm	ft.lbs.
Transfer			
Dynamic damper <6G74>	70	7.0	51
Side cover	9	0.9	6.5
Sleeve clamp	19	1.9	14



SEALANTS

	Specified sealants and adhesives	Quantity
Transmission		
Oil pin	Threebond Seal Packing 1281	As required
Transfer		
Adapter gasket (transmission sides)	Threebond Seal Packing 1281	As required
Adapter gasket (transfer sides)	Mitsubishi genuine sealant	As required
	Part No. MD997740 or equivalent	
Chain cover	Mitsubishi genuine sealant	As required
	Part No. MD997740 or equivalent	
Rear cover	Mitsubishi genuine sealant	As required
	Part No. MD997740 or equivalent	
Transfer case plate	Mitsubishi genuine sealant	As required
	Part No. MD997740 or equivalent	
Poppet plug	3M ATD Part No. 8660 or equivalent	As required
Plug	3M ATD Part No. 8660 or equivalent	As required
Bolt (threads)	3M STUD Locking 4170 or equivalent	As required

NOTES

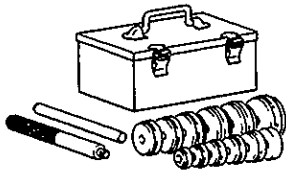
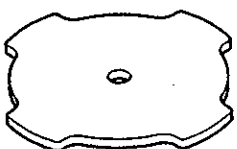
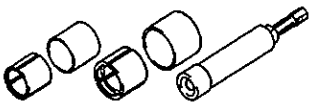
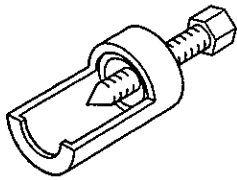
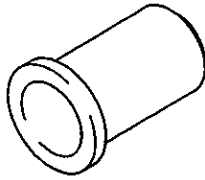
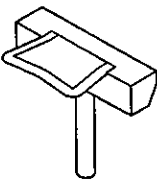
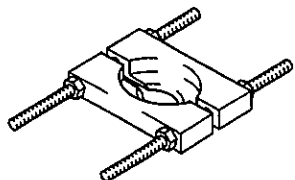
2. SPECIAL TOOLS

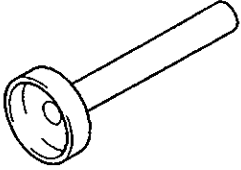
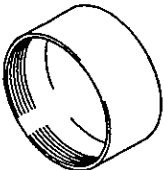
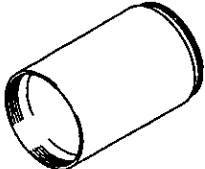
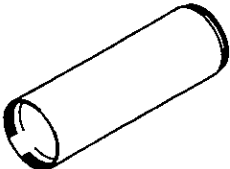

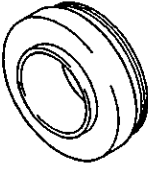
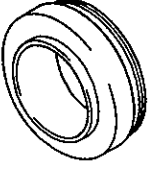
Tool	Number	Name	Use
	MB990925 MB990929 MB990934 MB990936 MB990938	Bearing and oil seal installer set	Installation of bearing and oil seal
	MB991556	Spring compressor	Removal and installation of O/D support snap ring
	MD998192	Counter gear bearing puller	Installation of transfer drive shaft bearing (top part only used)
	MD998212	Oil pump puller	Removal of oil pump
	MD998382	Countershaft front oil seal installer	Installation of oil pump oil seal
	MD998727	Oil pan remover	Removal of oil pan
	MD998801	Bearing remover	Removal of bearings and gears

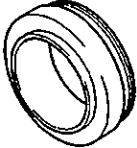
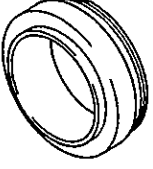
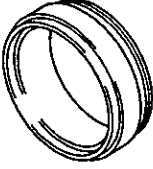
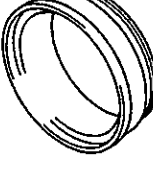
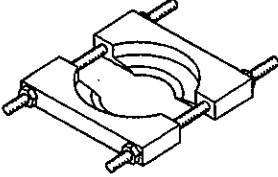
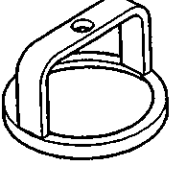
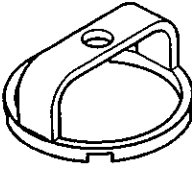
Tool	Number	Name	Use
	MD998803	Differential oil seal installer	Installation of input gear oil seal
	MD998812	Installer cap	Installation of bearings and gears
	MD998813	Installer-100	Installation of bearings and gears
	MD998814	Installer-200	Installation of bearings and gears
	MD998818	Installer adapter	Installation of bearings and gears
	MD998819	Installer adapter	Installation of bearings and gears
	MD998821	Installer adapter	Installation of bearings and gears

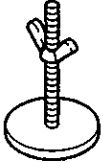
Tool	Number	Name	Use
	MD998823	Installer adapter	Installation of bearings and gears
	MD998824	Installer adapter	Installation of bearings and gears
	MD998829	Installer adapter	Installation of bearings and gears
	MD998830	Installer adapter	Installation of bearings and gears
	MD998917	Bearing remover	Removal of bearings
	MD998921	Spring compressor	Removal and installation of snap ring for O/D direct clutch, direct clutch, forward clutch and first & reverse brake
	MD998923	Spring compressor	Removal and installation of second brake snap ring

Tool	Number	Name	Use
	MD998924	Spring ring compressor retainer	Used with MD998921, MD998922 and MD998923

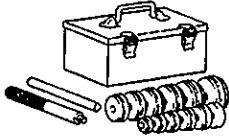
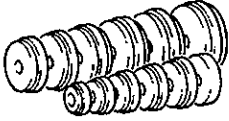
CONTENTS OF BEARING AND OIL SEAL INSTALLER SET MB990925

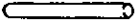
Set	Contents			
	Tool	Name	Tool No.	Diameter mm (in.)
 <p>Bearing and oil seal installer set MB990925</p>		Installer adapter	MB990926	39 (1.535)
			MB990927	45 (1.772)
			MB990928	49.5 (1.949)
			MB990929	51 (2.008)
			MB990930	54 (2.126)
			MB990931	57 (2.244)
			MB990932	61 (2.402)
			MB990933	63.5 (2.500)
			MB990934	67.5 (2.657)
			MB990935	71.5 (2.815)
			MB990936	75.5 (2.972)
	MB990937	79 (3.110)		
		Installer bar	MB990938	—
	Brass bar	MB990939	—	

3. TRANSMISSION AND TRANSFER

DISASSEMBLY AND REASSEMBLY

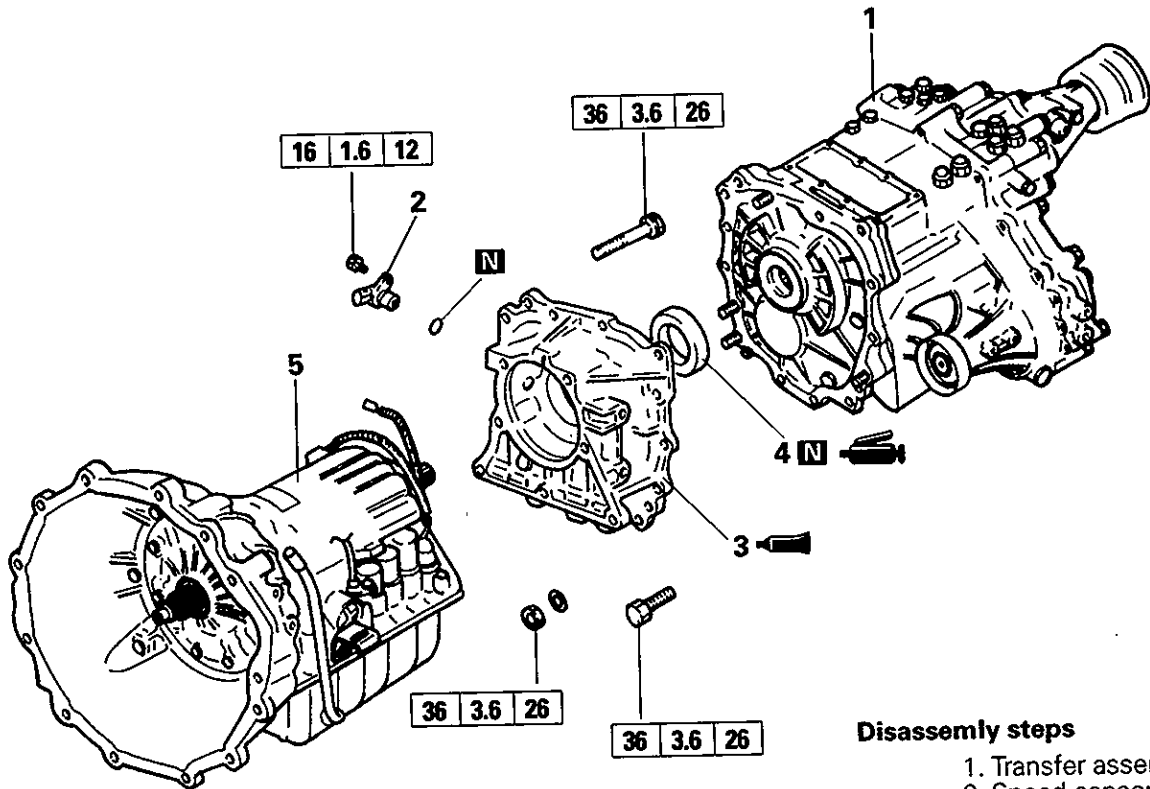

Disassembly steps

1. Transfer assembly
2. Speed sensor
- ▶B◀ 3. Transfer case adapter
- ▶A◀ 4. Oil seal
5. Transmission assembly

TRA0451

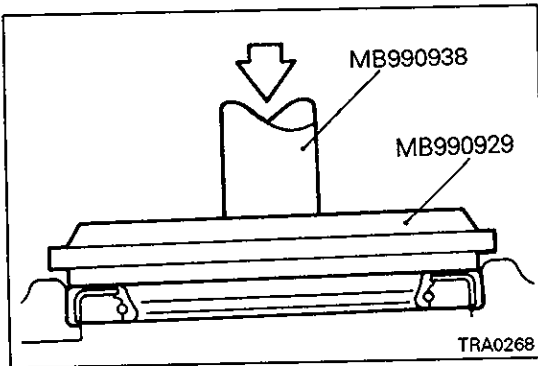

TRA0268

REASSEMBLY SERVICE POINTS

▶A◀ OIL SEAL INSTALLATION

- (1) Using the special tool, install an oil seal on the adapter, and then pack the oil seal lips with grease.

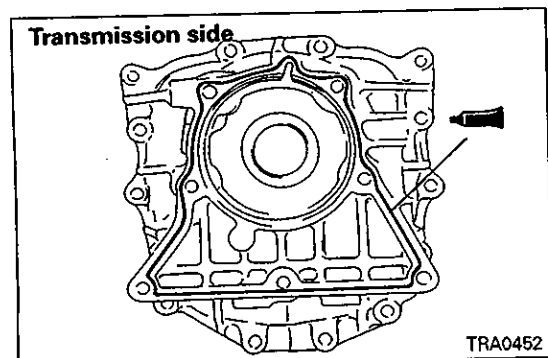

TRA0452

▶B◀ TRANSFER CASE ADAPTER INSTALLATION

Specified sealant:

Threebond Seal Packing 1281 Transmission side
 Mitsubishi genuine sealant Part No. MD997740
 or equivalent Transfer side

Caution

- Squeeze the sealant out evenly to make sure that it is not broken or excessively supplied.

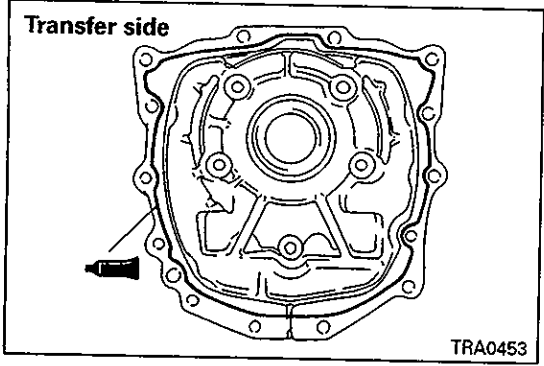

4. TRANSMISSION

DISASSEMBLY

Caution

- When removing the transmission assembly from the vehicle, care must be taken to make sure that the oil pan is not struck by the transmission jack.
- The automatic transmission is composed of component parts of an especially high degree of precision. Therefore, handle these component parts very carefully during disassembly so as not to scar or scratch them.
- When separating cases and other parts made of light alloys from the junctions, lightly hit them with a soft hammer (plastic hammer) if it is difficult to release them. Don't jimmy them free using a screwdriver or the like.
- Replace a rubber mat on the workbench so that it may always be kept clean.
- During disassembly, do not use cloth gloves or shop towels. If such items are required, use either articles made of nylon or paper towels.
- Clean all disassembled parts thoroughly. Metal parts may be cleaned with ordinary detergents, but must be thoroughly air-dried.
- Clean the clutch discs, brake discs, and other resin and rubber parts by using ATF (automatic transmission fluid), being very careful that dust, dirt, etc. do not adhere to them.
- If the transmission proper is damaged, also disassemble and clean the cooler system.

- (1) Remove sand, mud, etc. from the exterior of the transmission.
- (2) Place the transmission assembly on a bench with the oil pan down.

Caution

- Do not place the assembly with the oil pan up before the oil pan is removed. This is necessary to prevent foreign matter in the oil pan from entering the valve body.

- (3) Remove the torque converter.
- (4) Remove the oil level gauge and oil filler tube. Remove the O-rings from the oil filler tube.
- (5) Remove the harness connector bracket and throttle cable clamp.
- (6) Remove the control shaft lever.

- (7) Unlock the lock washer and remove the inhibitor switch. Remove the lock washer and grommet.

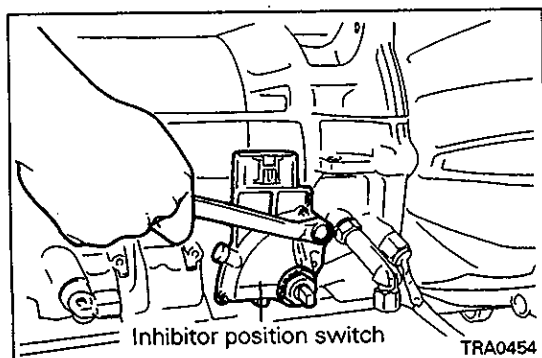

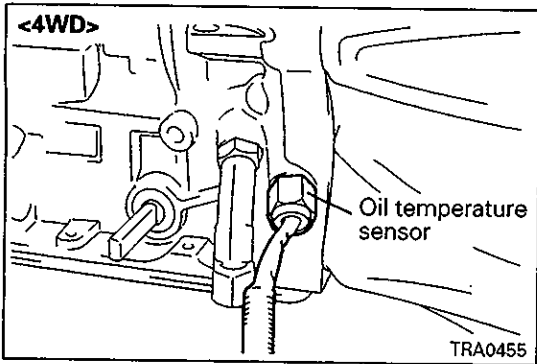

(8) Remove the oil temperature sensor.

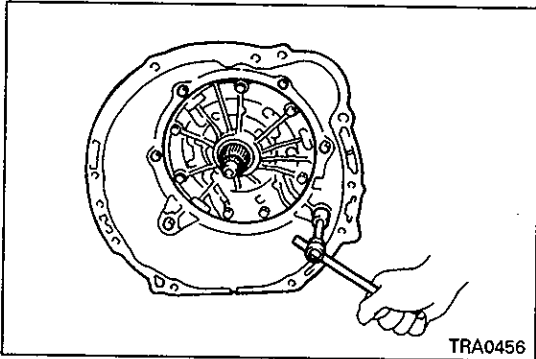

(9) Remove the torque converter housing.

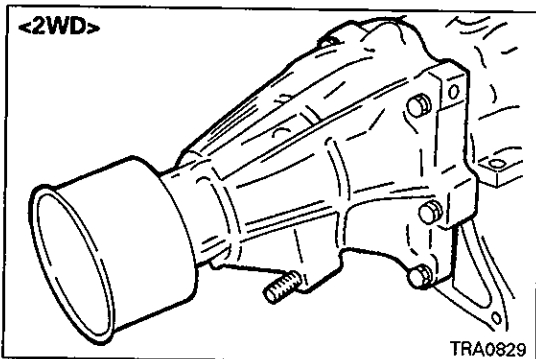

(10) Remove the extension housing and gasket. <2WD>

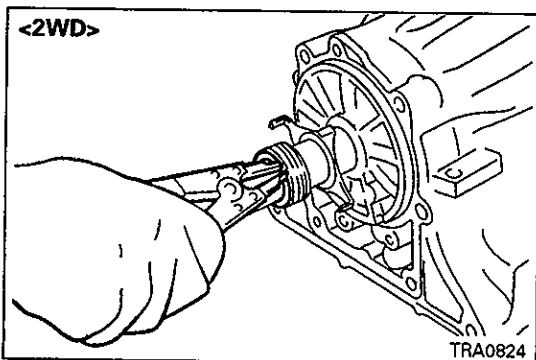

(11) Remove the snap ring and speedometer drive gear. Remove the sensor rotor and then the key. <2WD>

Caution

- Be careful not to bend the blades of the sensor rotor.

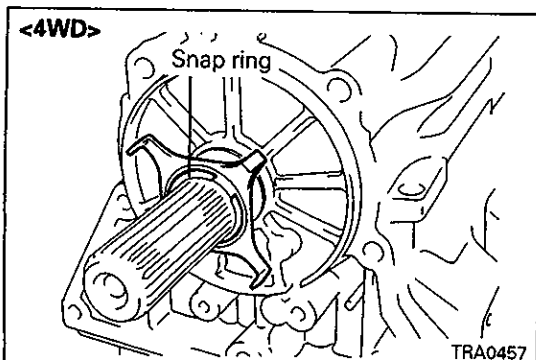

(12) Remove the snap ring. Remove the sensor rotor and then the key. <4WD>

Caution

- Be careful not to bend the blades of the sensor rotor.

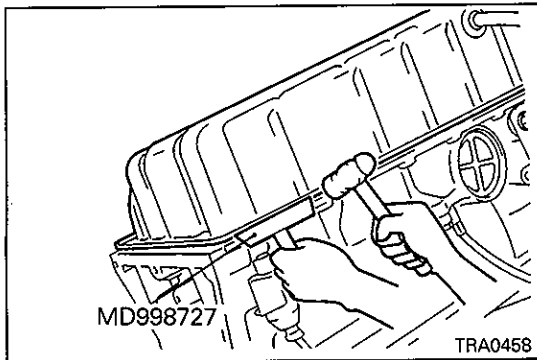

(13) Remove the 19 oil pan bolts and use the special tool (oil pan remover) to remove the oil pan.

Caution

- Drive in the special tool carefully so as not to deform the oil pan.

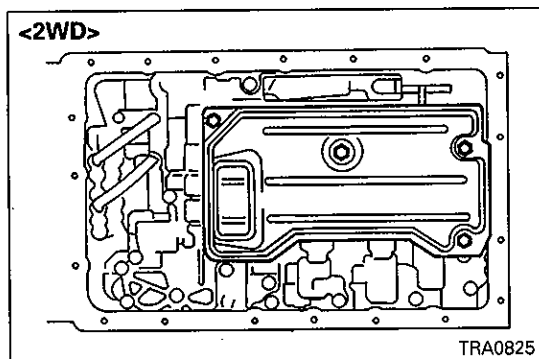

(14) Remove the 4 bolts and then remove the oil screen assembly. <2WD>

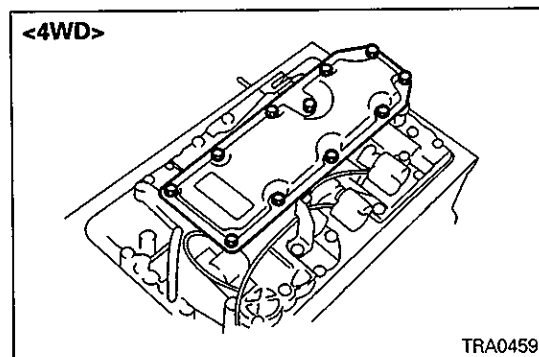

(15) Remove the 11 bolts and then remove the oil screen assembly and gasket. <4WD>

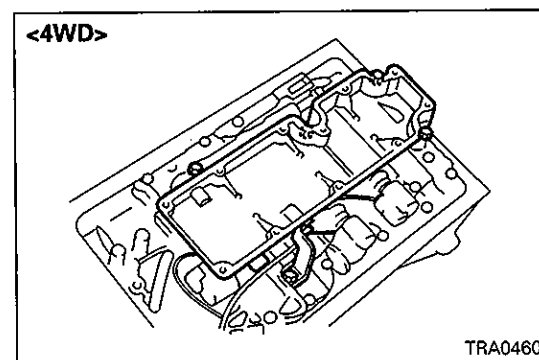

(16) Remove the 5 bolts and then remove the spacer and oil screen. <4WD>

(17) Remove the two gaskets. <4WD>

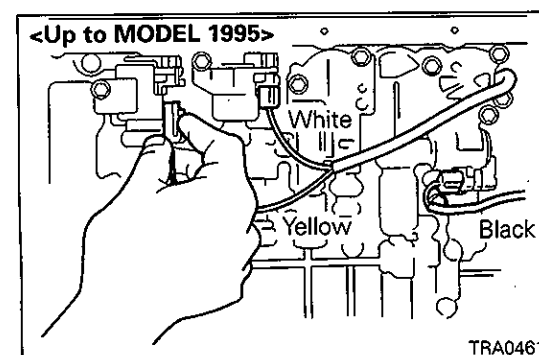

(18) Separate the 3 transmission solenoid connectors.

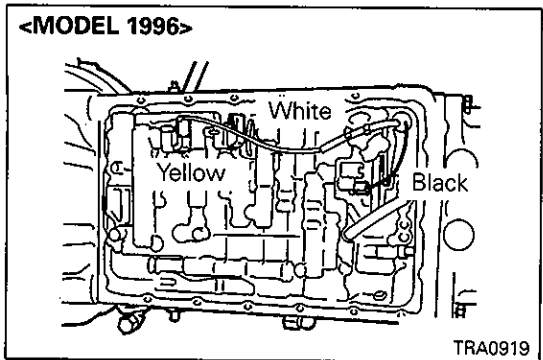

- (19) Remove the grommet stopper plate from the transmission case and then remove the transmission wire.
 (20) Remove the O-ring from the grommet.

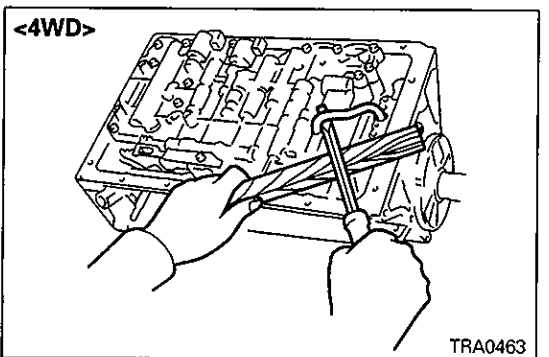
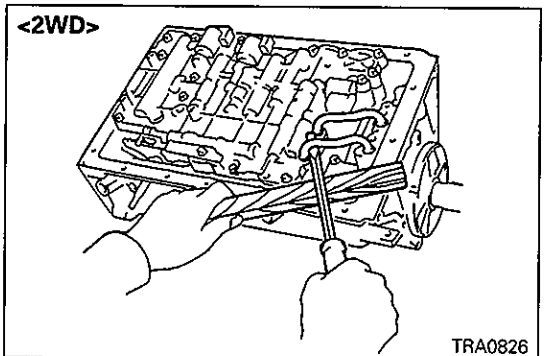
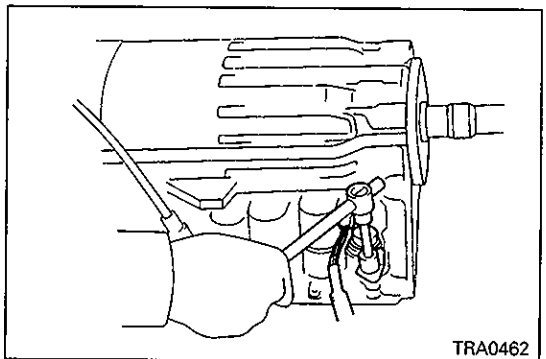

- (21) Using a screwdriver, wood piece, etc., remove the brake tubes.

Caution

- Be careful not to deform the brake tube.

- (22) Remove the 16 mounting bolts from the valve body.

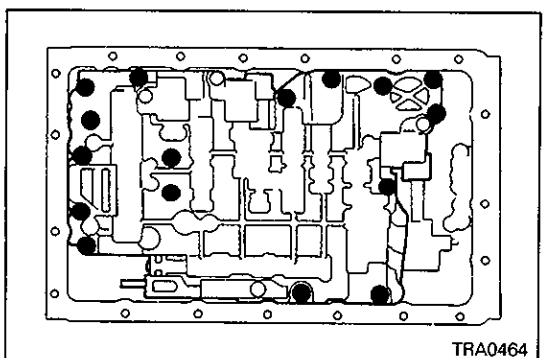

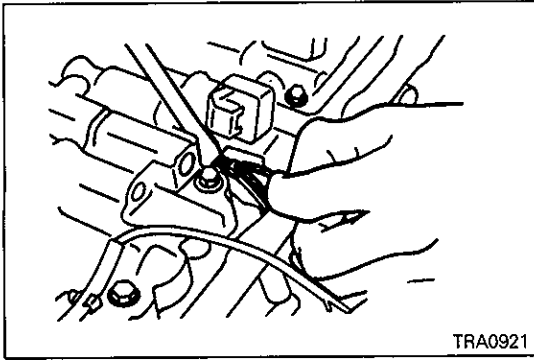

(23) Remove the throttle cable from the throttle cam. Then, remove the valve body.

Intentionally blank

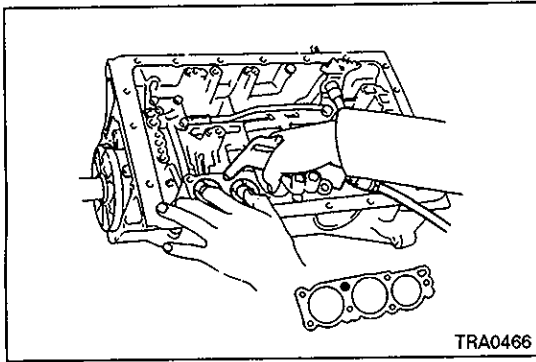

- (24) Remove the two springs from the C₀ accumulator piston.
 (25) Remove the check ball body and spring.
 (26) Remove the B₂ and C₂ accumulator pistons and two springs by blowing air slowly from the illustrated oil hole.

NOTE

Both B₂ and C₂ pistons can be released by blowing air while pushing the B₂ piston stronger.

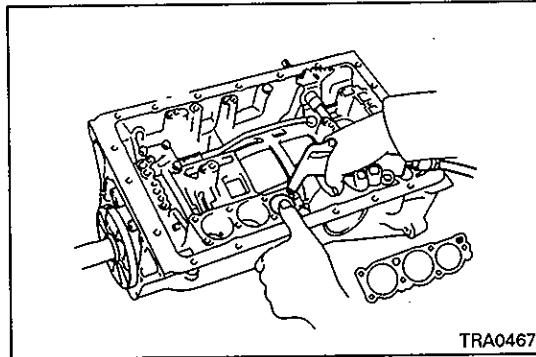

- (27) Remove the B₀ accumulator piston and spring by blowing air slowly from the illustrated oil hole.

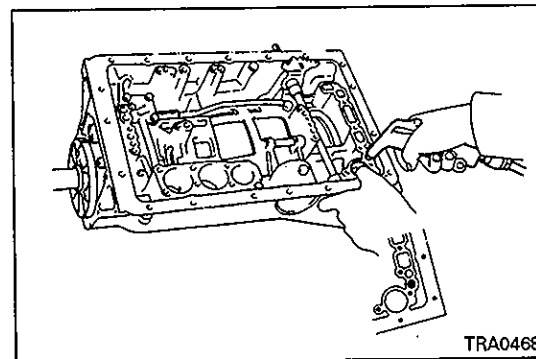

- (28) Remove the C₀ accumulator piston and spring by blowing air slowly from the illustrated oil hole.
 (29) Remove the O-ring from each piston.

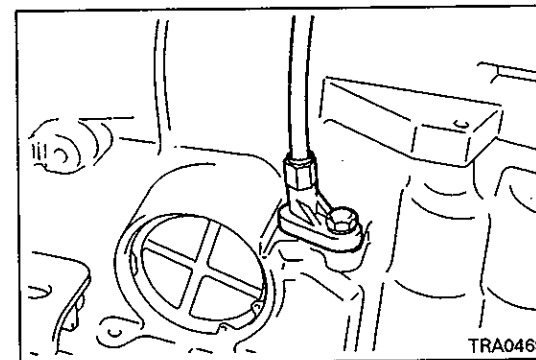

- (30) Remove the bolt. Pull out the throttle cable while holding the retainer.
 (31) Remove the O-ring from the throttle cable.

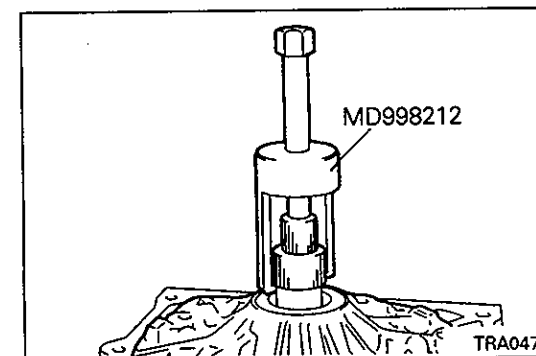

- (32) Remove the 7 bolts attaching the oil pump.
 (33) Using the special tool (oil pump puller), remove the oil pump.

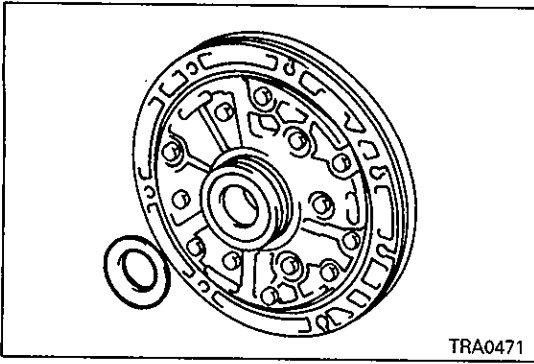

(34) Remove the race from the rear side of the oil pump.

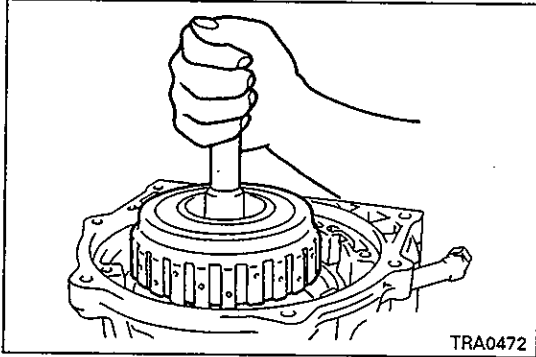

(35) Holding the input shaft by hand, remove the overdrive planetary gear assembly and overdrive direct clutch assembly.

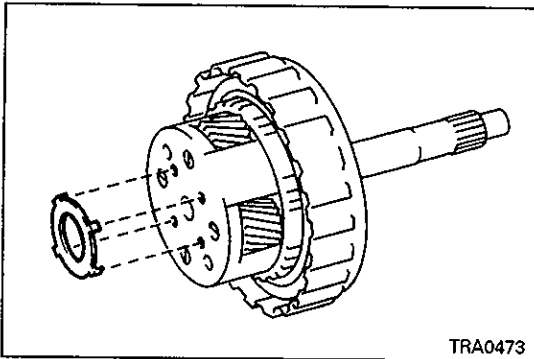

(36) Remove the race from the rear side of the overdrive planetary gear.

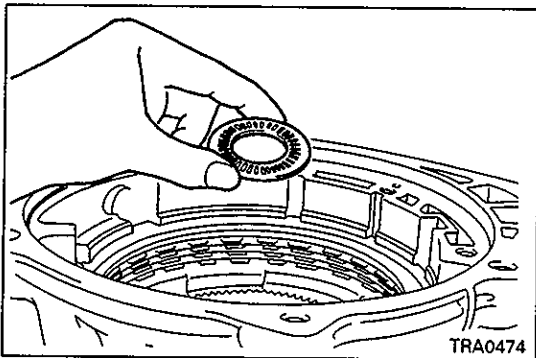

(37) Remove the bearing and race.

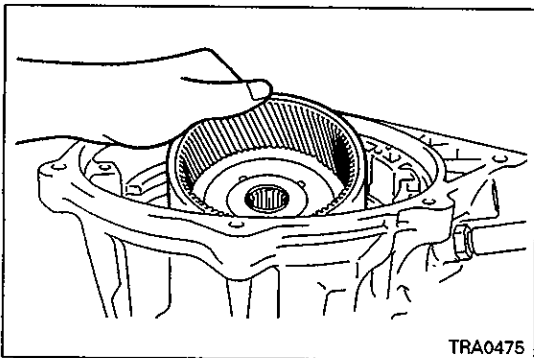

(38) Remove the overdrive planetary ring gear.

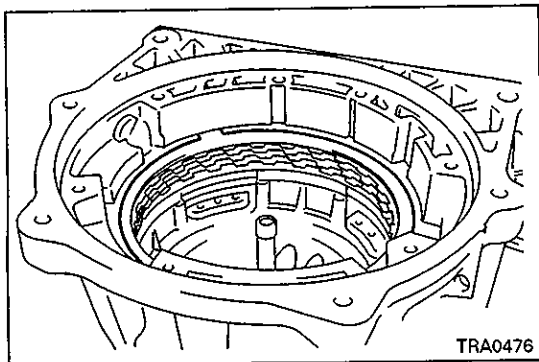

(39) Remove the snap ring.

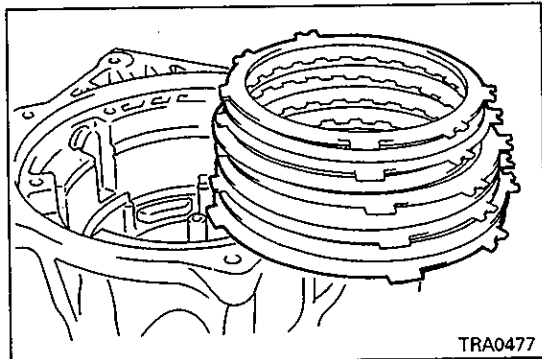

(40) Remove the two flanges, four discs and three plates of the overdrive brake.

NOTE

Remember the direction in which the brake flanges have been installed.

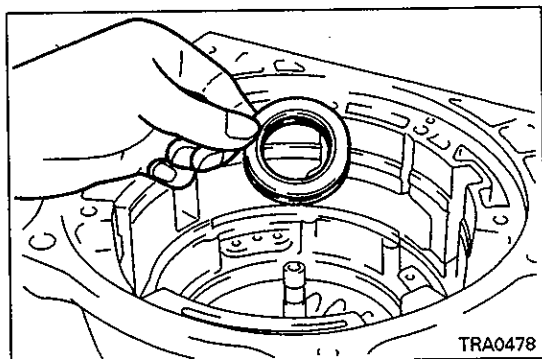

(41) Remove the race and bearing.

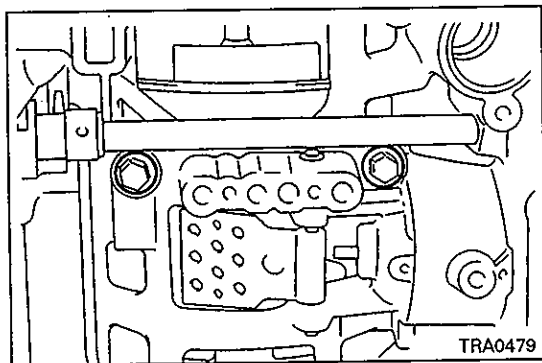

(42) Remove the two bolts attaching the overdrive support.

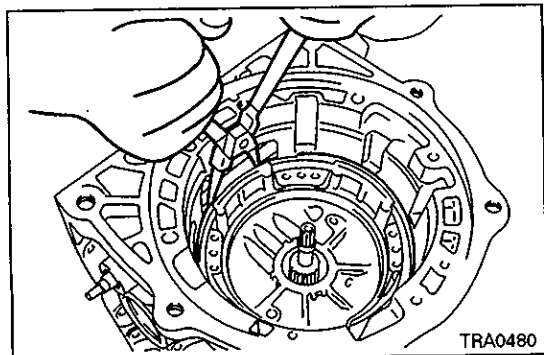

(43) Remove the snap ring.

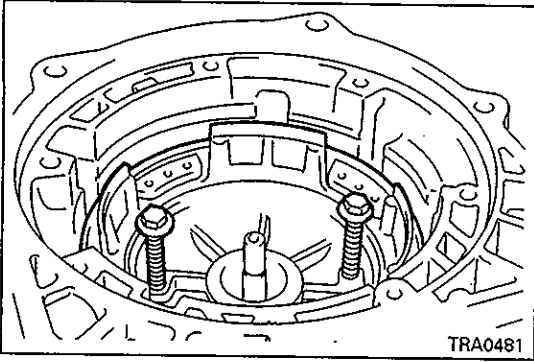

(44) Remove the overdrive support assembly by making use of the two overdrive support mounting bolts.

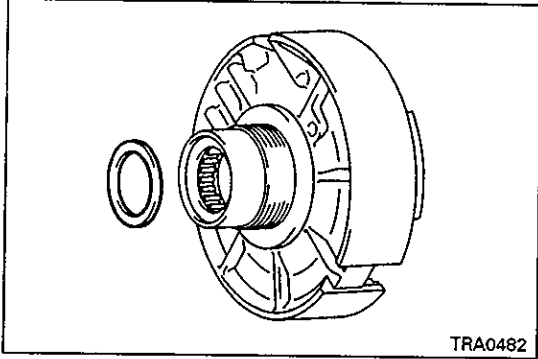

(45) Remove the race from the rear side of the overdrive support assembly.

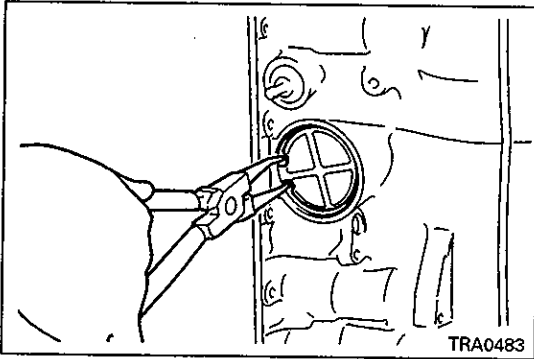

(46) Remove the snap ring from the second coast brake piston.

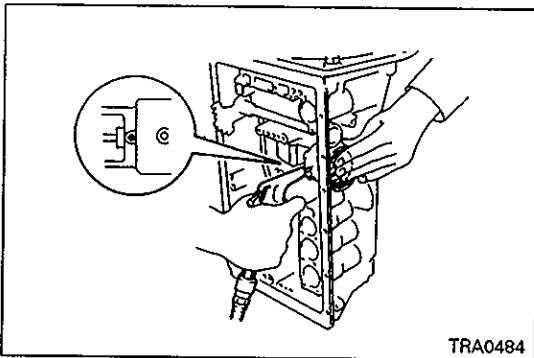

(47) Remove the second coast brake cover, piston assembly and spring by blowing air slowly from the illustrated oil hole.

Caution

- Use a shop towel, etc. to prevent the cover and fluid from popping and gushing out.

(48) Remove the two O-rings from the piston cover.

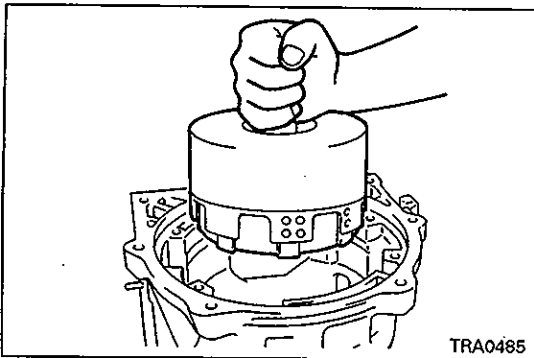

(49) Holding the input shaft of the forward clutch, remove the forward clutch assembly and direct clutch assembly.

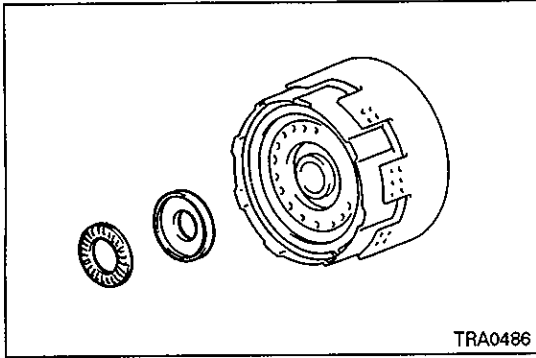

(50) Remove the race and bearing from the rear side of the forward clutch assembly.

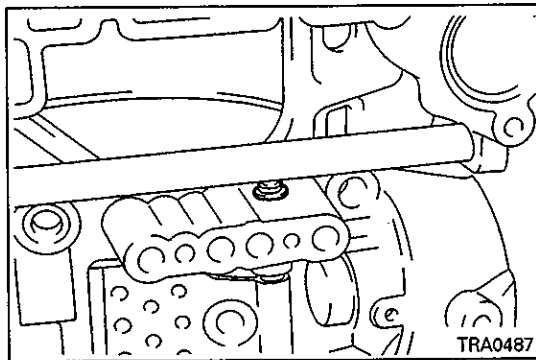

(51) Push the E-ring out of position and pull out the pin downward. Then remove the second coast brake band.
 (52) Remove the E-ring from the pin.

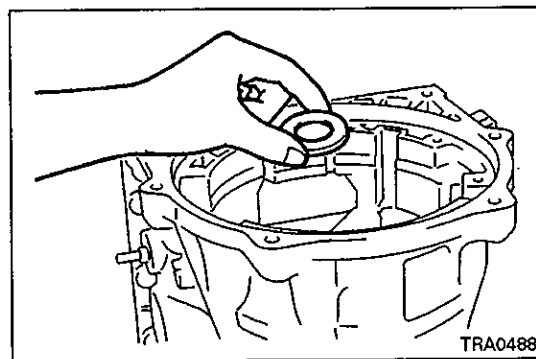

(53) Remove the race.

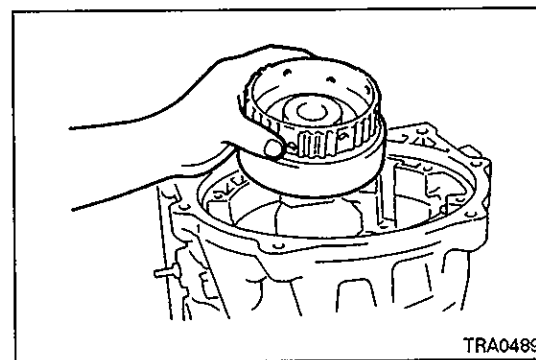

(54) Remove the front planetary ring gear.

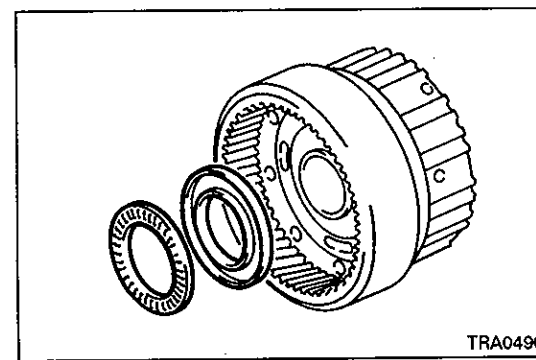

(55) Remove the race and bearing from the rear side of the front planetary ring gear.

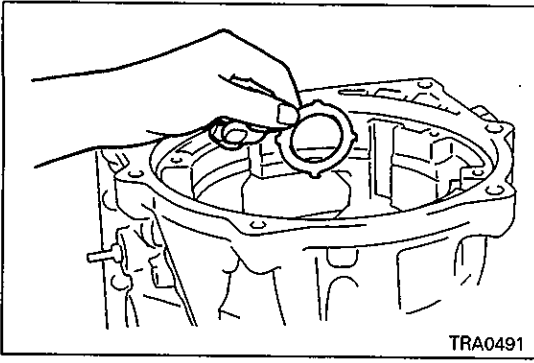

(56) Remove the race.

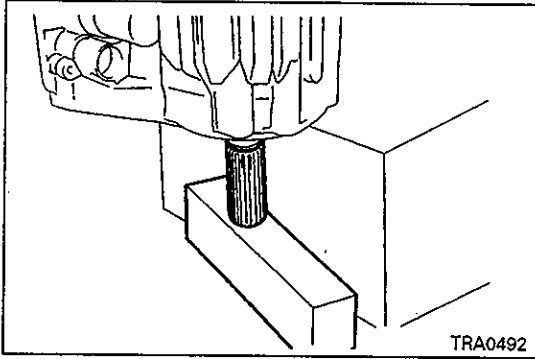

(57) Use wood pieces or the like so as to push the output shaft a little toward the front side.

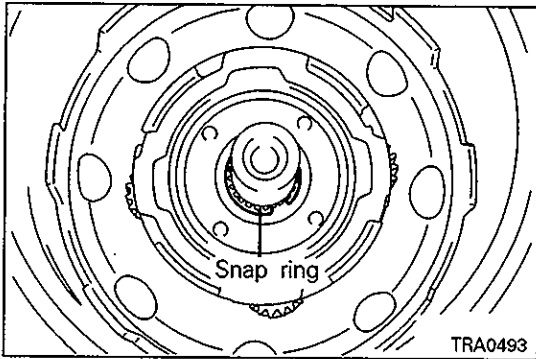

(58) Remove the snap ring.

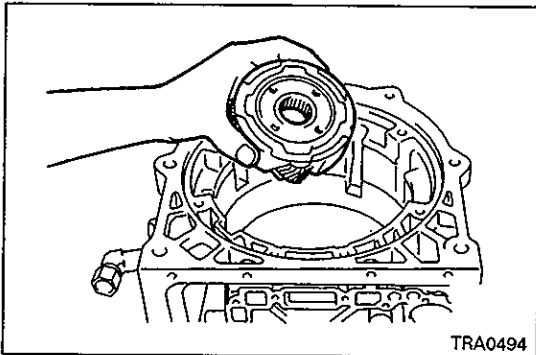

(59) Remove the front planetary gear assembly.
(60) Remove the bearing.

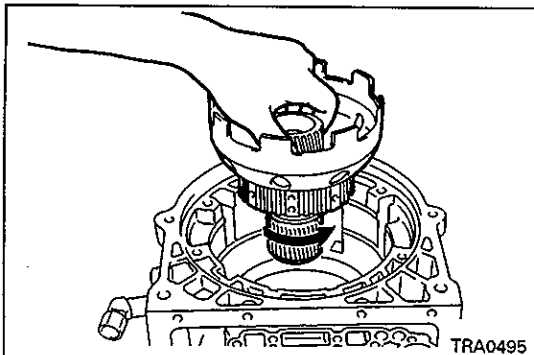

(61) Rotate the sun gear input drum counterclockwise to remove it together with the one-way clutch assembly.

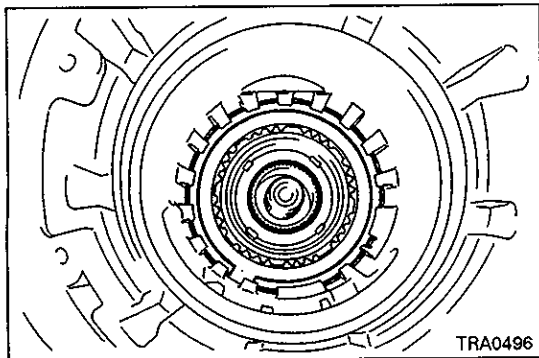

(62) Remove the snap ring.

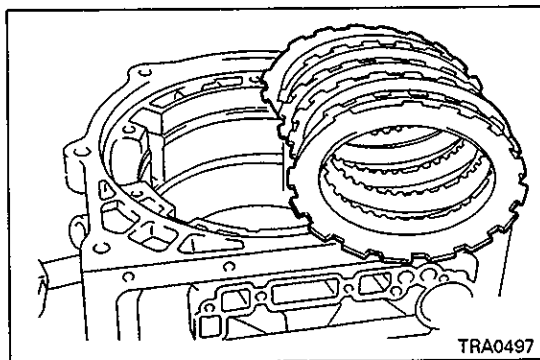

(63) Remove the flange, five discs and five plates of the flange.

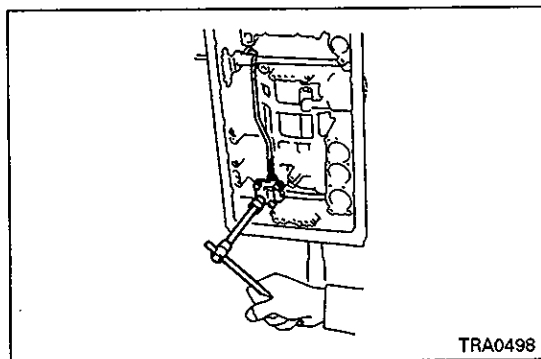

(64) Remove the three bolts and then remove the parking lock pawl bracket.

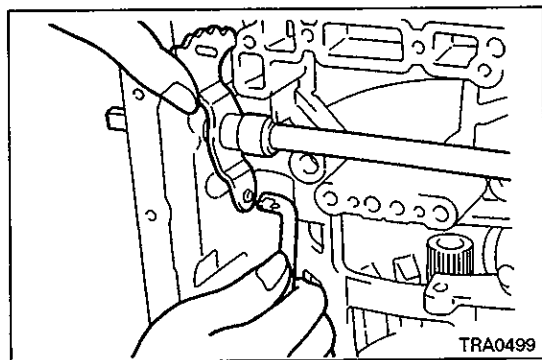

(65) Remove the parking lock rod from the manual valve lever.

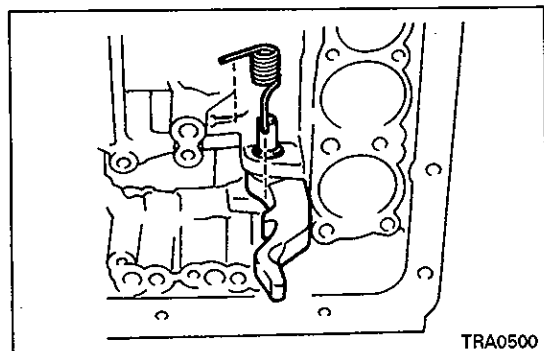

(66) Remove the spring, parking lock pawl shaft and pawl.
 (67) Remove the E-ring from the parking lock pawl shaft.

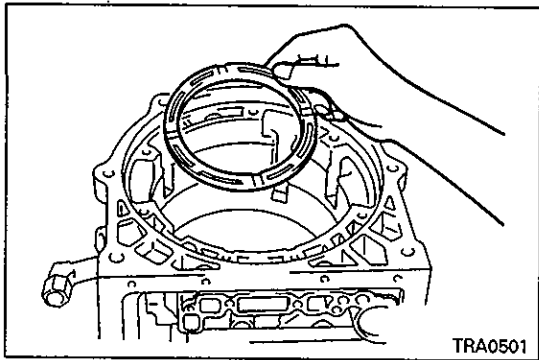

(68) Remove the second brake piston sleeve.

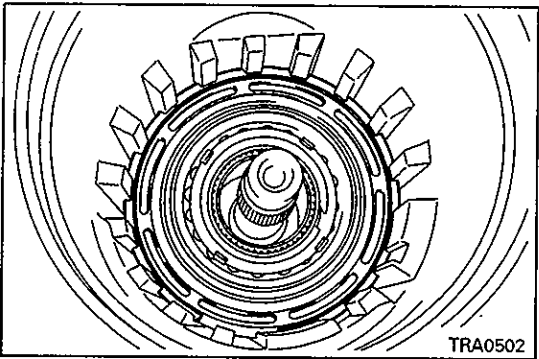

(69) Remove the snap ring.

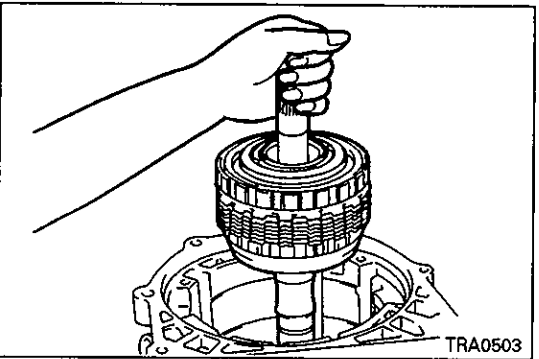

(70) Remove the output shaft, second brake drum sub-assembly and rear planetary gear assembly together.

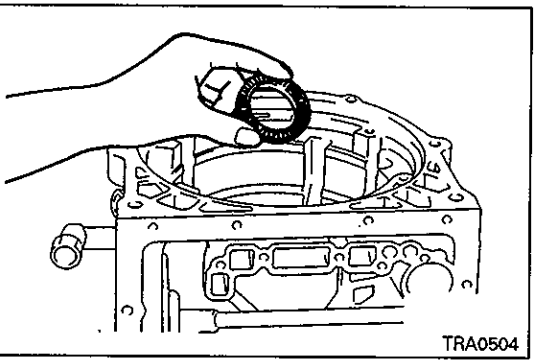

(71) Remove the bearing with the attached race from the transmission case.

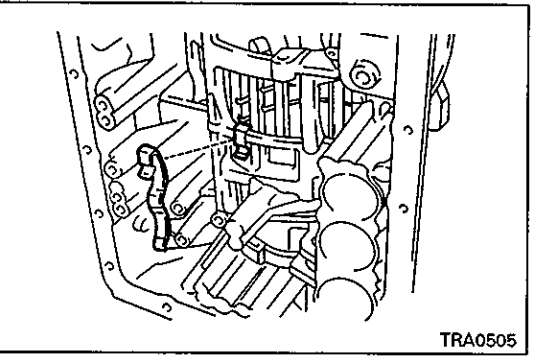

(72) Remove the leaf spring from the transmission case.

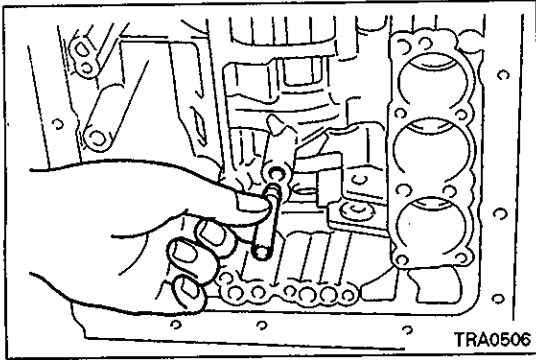

(73) Remove the brake drum gasket.

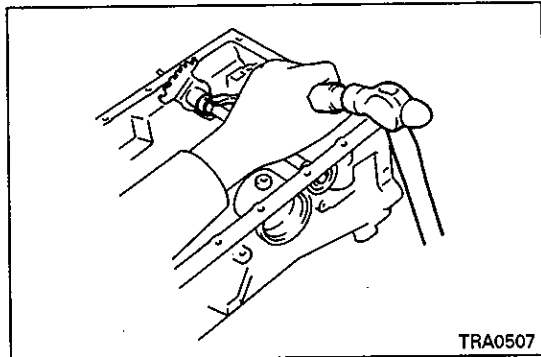

(74) Using a screwdriver, etc., unstick the spacer.

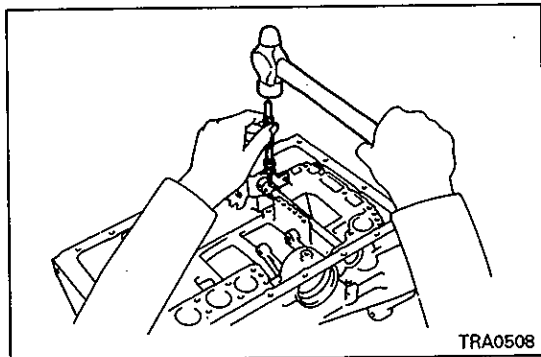

(75) Using a pin punch, drive out the slotted spring pin.

(76) Pull out the manual valve lever shaft and remove the manual valve lever.

(77) Remove the spacer from the manual valve lever.

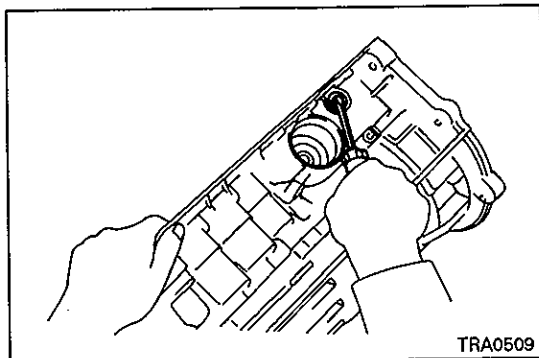

(78) Remove the two oil seals from the manual valve lever shaft.

REASSEMBLY**Caution**

- The automatic transmission is composed of component parts of an especially high degree of precision. During reassembly, therefore, handle these component parts very carefully so as not to scar or scratch them. Damage may cause fluid leakage and degeneration in performance. Check each part carefully before installation.
- Clean all parts thoroughly before reassembly. Metal parts may be cleaned with ordinary detergents, but must be thoroughly air-dried.
- Clean the clutch discs, brake discs, resin thrust plates and rubber parts by using ATF (automatic transmission fluid), being very careful that dust, dirt, etc. do not adhere to them.
- Do not reuse gaskets, oil seals, or other rubber parts. Be sure to replace them with new ones.
- Do not use grease other than petrolatum jelly.
- Apply ATF to friction components, rotating parts, and sliding parts before installation.
- Dip the new clutch discs and brake discs in ATF for at least two hours before installation.
- Do not apply sealer or adhesive to gaskets.
- When a bushing must be replaced, replace the assembly in which it is incorporated.
- Tighten each component to the specified torque.

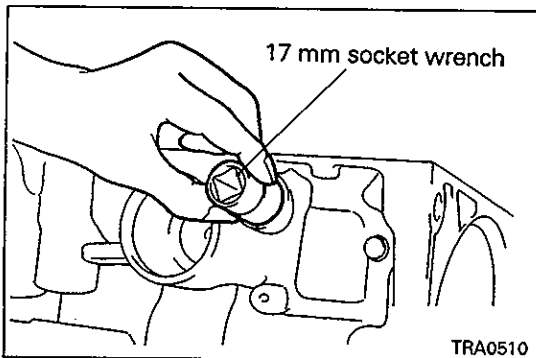

- (1) Using an appropriate socket wrench, etc., drive in the two oil seals until they are flush with the end face of the transmission case.

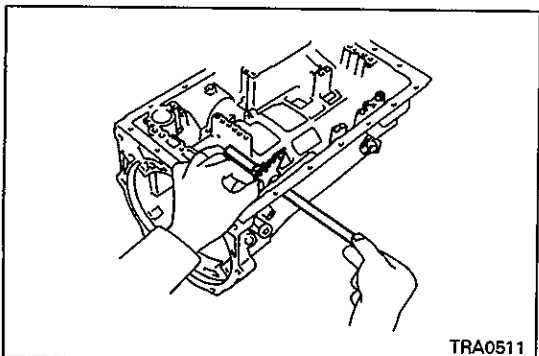

- (2) Install a new spacer to the manual valve lever.
- (3) Install the manual valve lever and shaft in the transmission case.

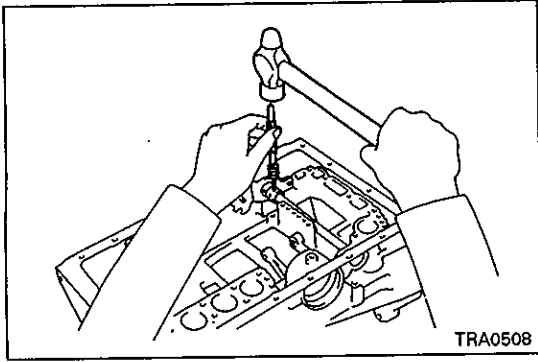

(4) Align the hole in the manual valve lever with that in the shaft and drive in a new slotted spring pin to fix them.

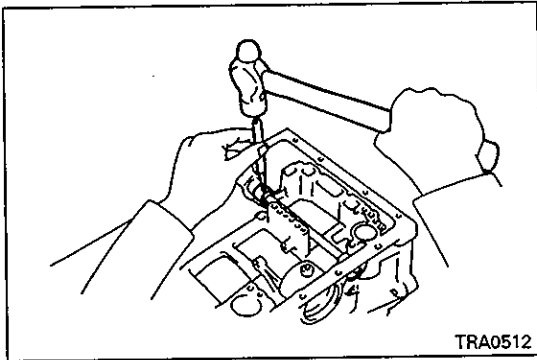

(5) Align the indentation in the manual valve lever with the spacer hole and stake it firmly using a punch.
 (6) Check that the manual valve lever shaft rotates smoothly.
 (7) Place wood pieces (used in disassembly) below the transmission case to prevent the output shaft from dropping.

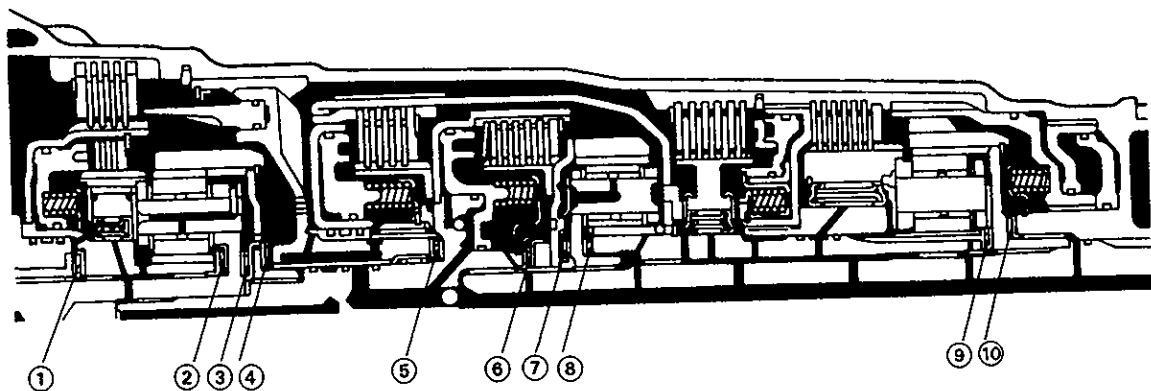
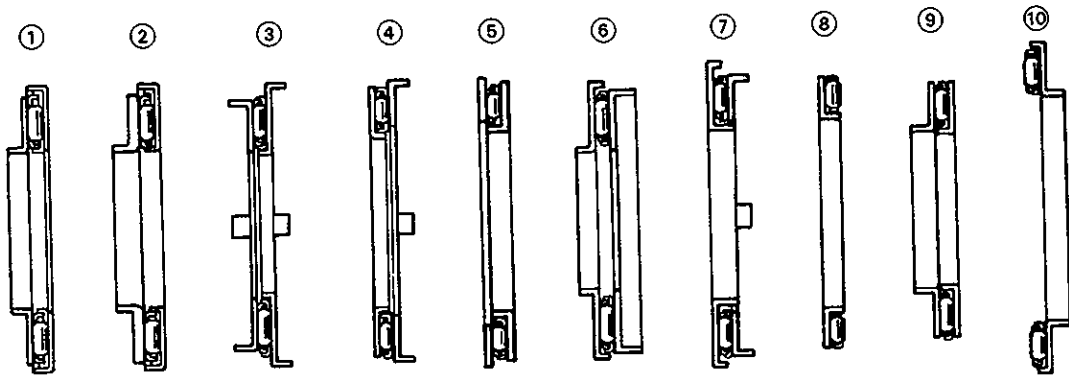

TRA0513

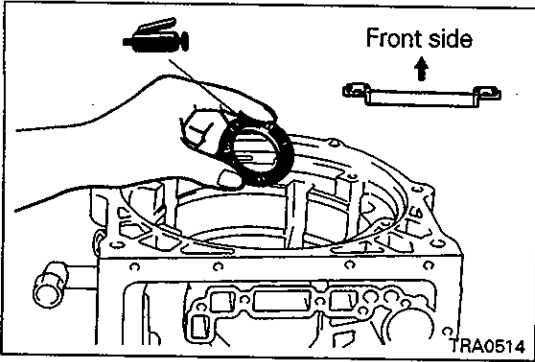

(8) Apply petrolatum to the bearing with race [57.7mm (2.27 in.) in outer diameter and 39.2 mm (1.54 in.) in inner diameter] and attach it in the transmission case.

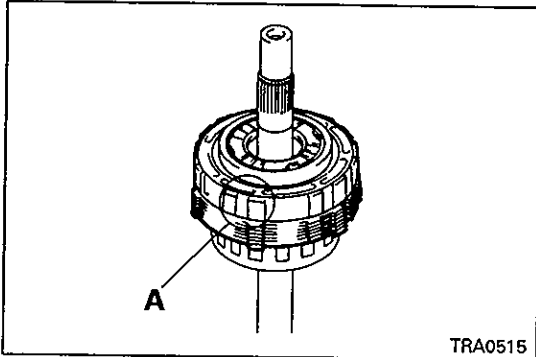

(9) As illustrated, align the lugs of the flange, disc, plate and second brake drum.

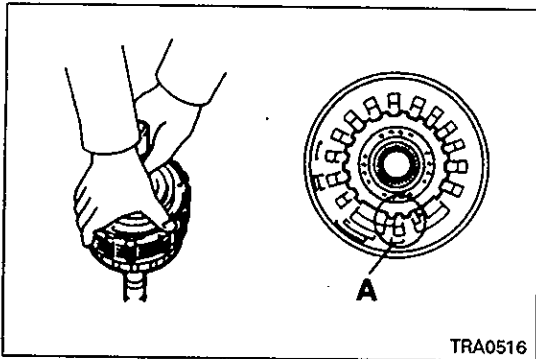

(10) Align the portion A illustrated in step (9) with the portion A of the transmission case. Install the output shaft, second brake drum sub assembly and rear planetary gear assembly together.

NOTE

While holding the input shaft, push the second brake drum.

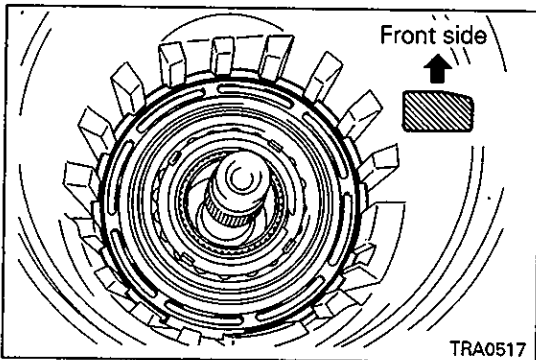

(11) Install the snap ring along the groove.

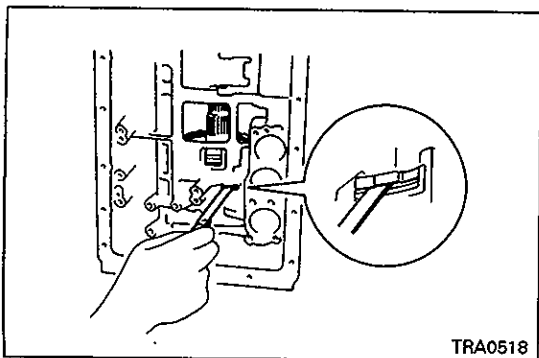

(12) Check the clearance between the second brake drum and the plate inserting a feeler gauge from the service hole on the valve body side.

Standard value:

0.6 – 1.12 mm (0.024 – 0.044 in.) 4M40, 6G72
 0.7 – 1.22 mm (0.028 – 0.048 in.) 6G74

If the clearance is not within this range, the second brake drum may have not been installed properly. In this case, reinstall it and check the clearance again.

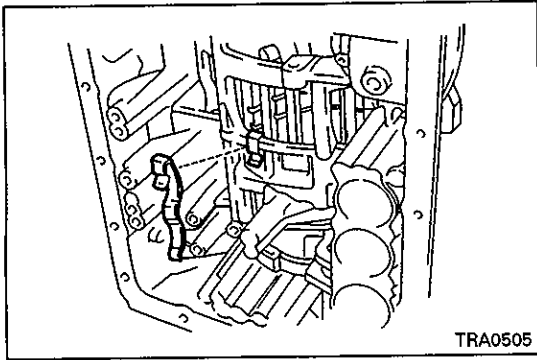

(13) Install the leaf spring.

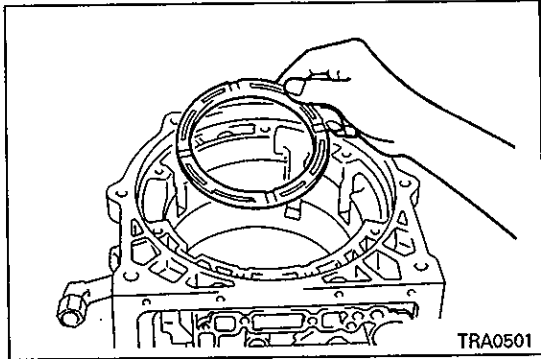

(14) With the indented side of the second brake piston sleeve up, install it firmly.
 (15) Check that the thrust washer No.2 is installed on the second brake drum.

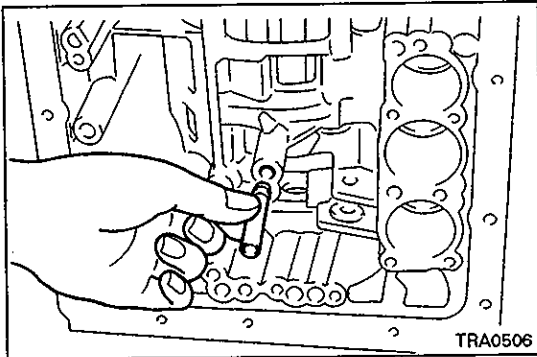

(16) Apply ATF to the new brake drum gasket and install it from the valve body side.

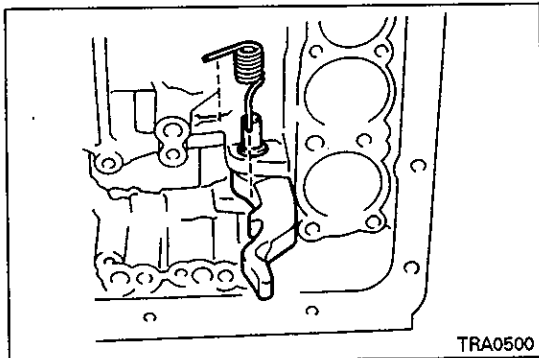

(17) Install the E-ring to the parking lock pawl shaft.
 (18) Install the parking lock pawl, shaft and spring.

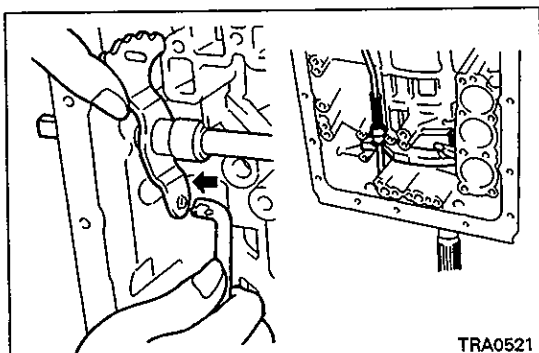

(19) Install the parking lock rod to the manual valve lever and place it on the lock pawl.
 (20) With three bolts, install the parking lock pawl bracket.

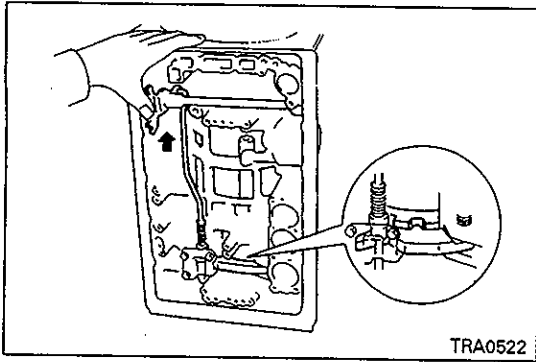

- (21) By shifting the manual valve lever toward the P range, check that the lock pawl locks the planetary ring gear.

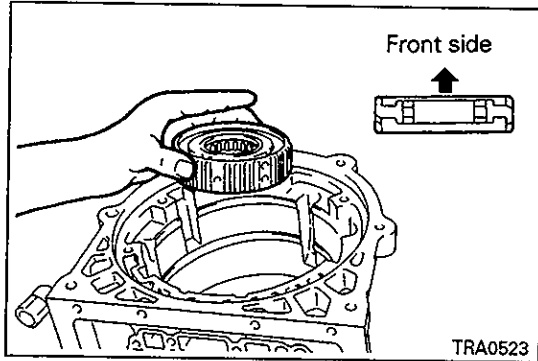

- (22) Install the one-way clutch assembly in the illustrated direction.

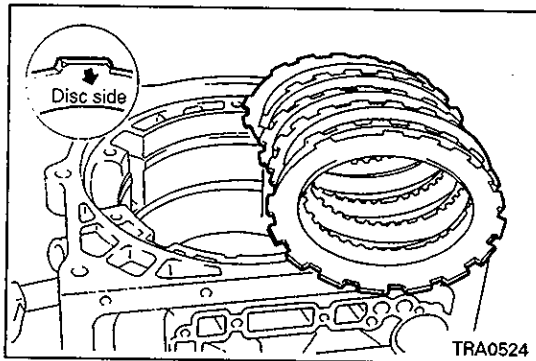

- (23) Install the 1.8 mm (0.070 in.) plate and then install the five discs and four 2.5 mm (0.098 in.) plates alternately.
 (24) Install the brake flange.

NOTE

The 1.8 mm (0.070 in.) plate and the brake flange must be installed in such a way that their chamfers face the disc side.

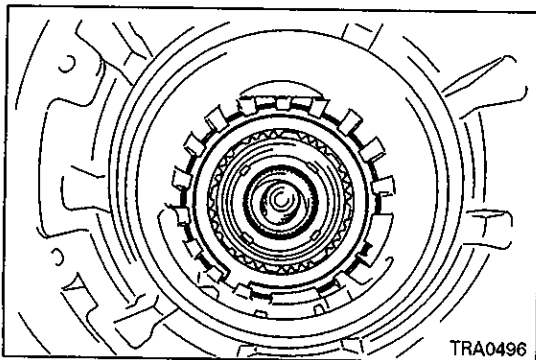

- (25) Install the snap ring.

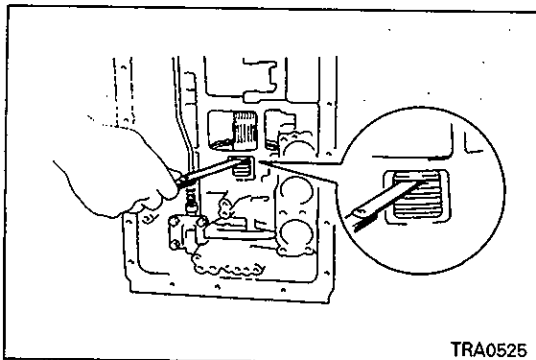

- (26) Check the clearance between the snap ring and flange by inserting a feeler gauge from the service hole on the valve body side.

Standard value: 0.62 – 1.98 mm (0.024 – 0.078 in.)

If the clearance is not within this range, an improper installation is suspected. In this case, reassemble and check the clearance again.

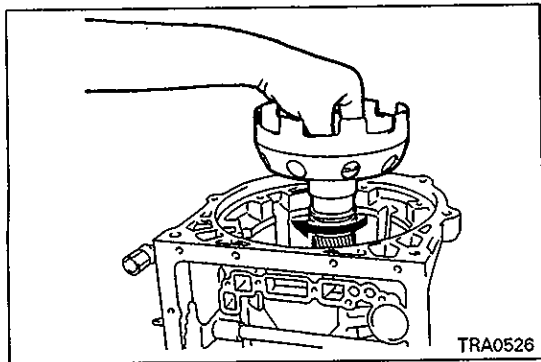

(27) Check that the one-way clutch No.1 washer is installed to the sun gear input drum. Push in the sun gear input drum fully while rotating it clockwise.

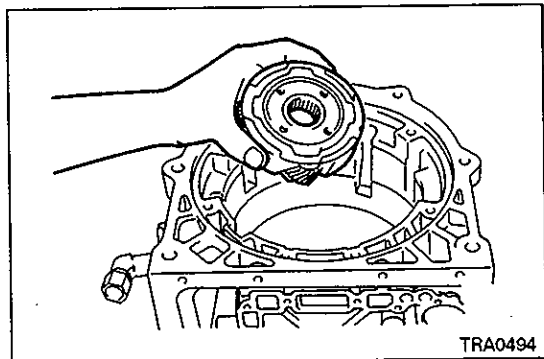

(28) Check that the race and bearing are installed to the rear side of the front planetary gear. Install the planetary gear assembly to the sun gear.

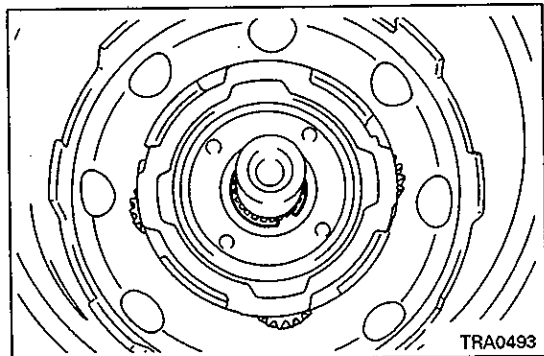

(29) While pushing the output shaft to the front side, install a new snap ring [23.7 mm (0.93 in.) in inner diameter] to the output shaft.

Caution

- Do not open the snap ring more than necessary.

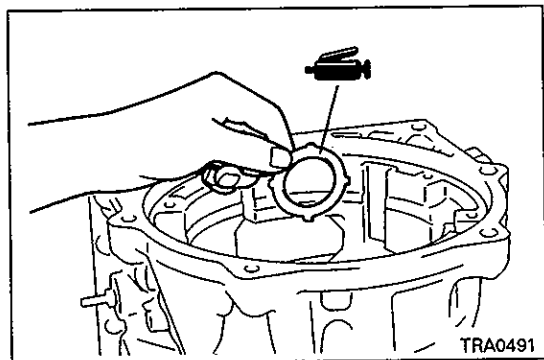

(30) Apply petrolatum to the race [47.8 mm (1.88 in.) in outer diameter and 34.3 mm (1.35 in.) in inner diameter]. Aligning its four lugs with the holes in the planetary gear assembly, install it thereon.

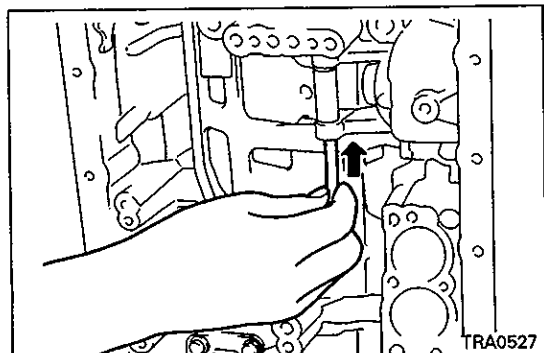

(31) Insert the second coast brake band in the transmission case.
 (32) Attach a new E-ring to one side of the pin and install it through the second coast brake band.

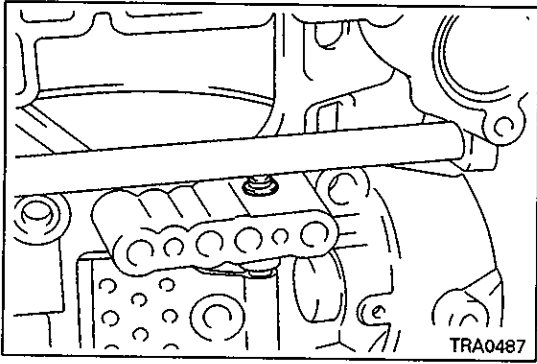

(33) Attach a new E ring to the upper side of the pin.

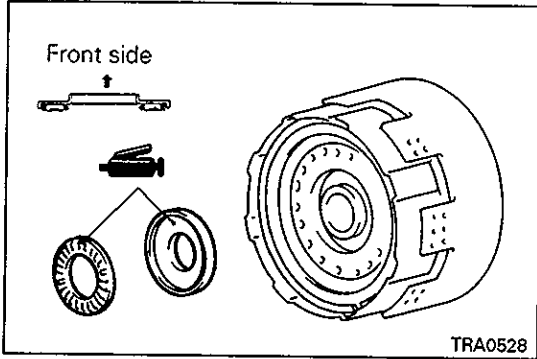

(34) Apply petrolatum to the front side race [48.9 mm (1.93 in.) in outer diameter and 26.0 mm (1.02 in.) in inner diameter] and bearing [46.7 mm (1.84 in.) in outer diameter and 26.0 mm (1.02 in.) in inner diameter] and install them to the rear side of the forward clutch.

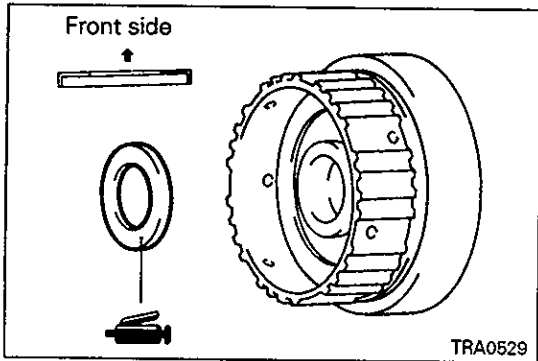

(35) Apply petrolatum to the rear side race [47.0 mm (1.85 in.) in outer diameter and 26.8 mm (1.06 in.) in inner diameter] and install it to the front side of the front planetary ring gear.

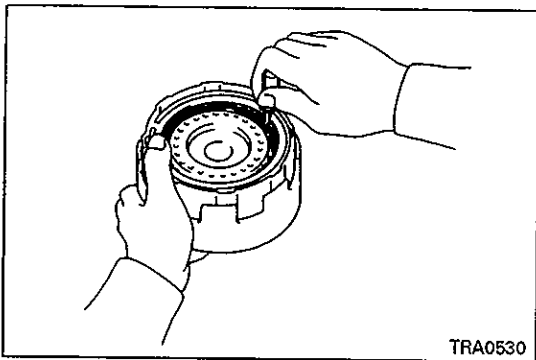

(36) Using a screwdriver, align the forward clutch disc lugs.

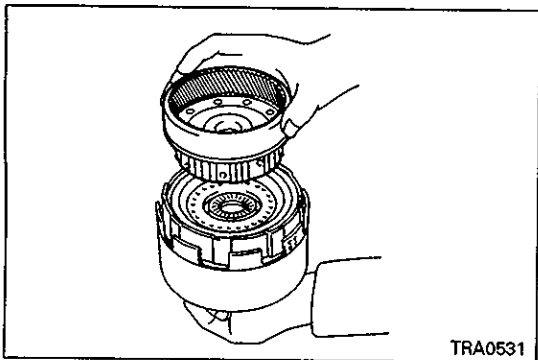

(37) Install the front planetary ring gear to the forward clutch assembly by lightly pushing and rotating it.

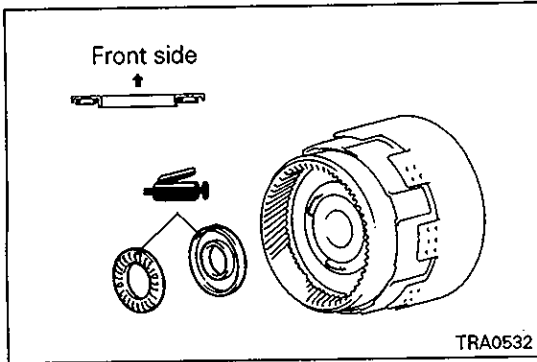

(38) Apply petrolatum to the race [53.6 mm (2.11 in.) in outer diameter and 30.6 mm (1.20 in.) in inner diameter] and bearing [47.4 mm (1.87 in.) in outer diameter and 32.6 mm (1.28 in.) in inner diameter] and install them to the ring gear.

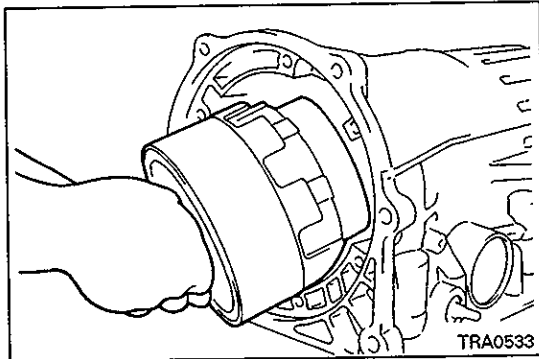

(39) Install the direct clutch assembly, forward clutch assembly and ring gear together in the transmission case.

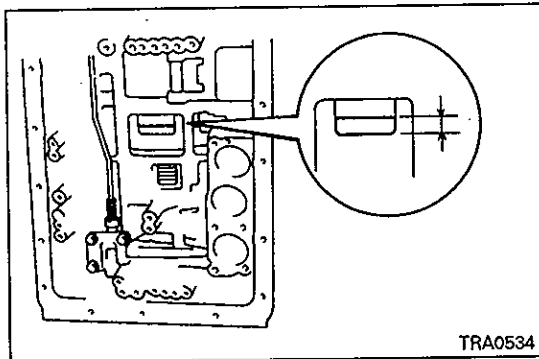

(40) Using a caliper, check the clearance between the sun gear input drum and the lug edge of the direct clutch drum.

Reference value: 5.3 - 7.3 mm (0.21 - 0.29 in.)

If the clearance is not within this range, the direct clutch, forward clutch and ring gear may have not be installed properly. In this case, reinstall them and check the clearance again.

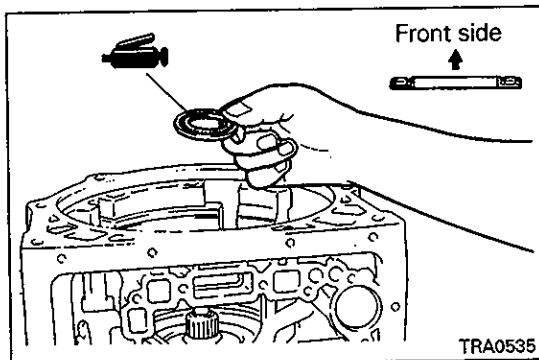

(41) Apply petrolatum to the bearing with race [47.6 mm (1.87 in.) in outer diameter and 33.7 mm (1.33 in.) in inner diameter] and slide it over the input shaft of the forward clutch.

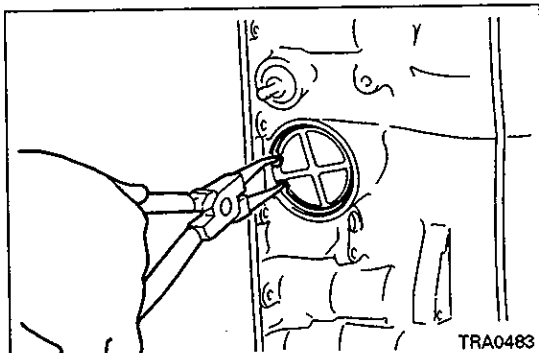

(42) Apply ATF to two new O-rings and attach them to the piston cover.

(43) Install the spring, piston assembly and piston cover.

(44) Install the snap ring.

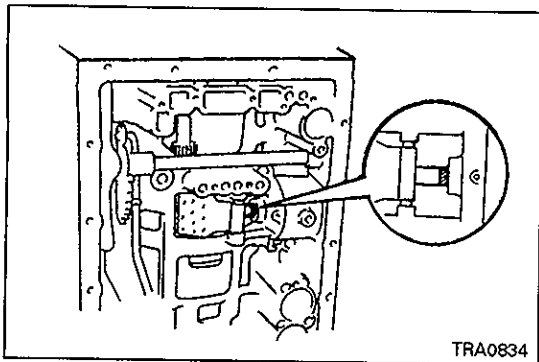

TRA0834

(45) Apply minimum oil on the second coast brake piston rod.

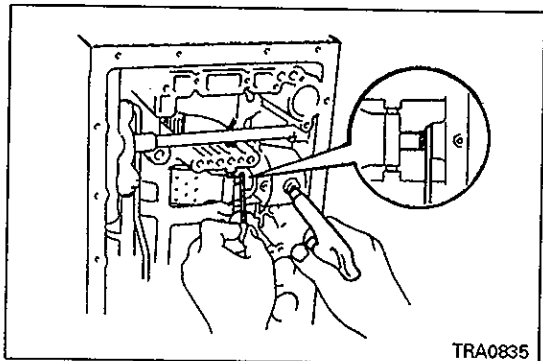

TRA0835

(46) Apply air pressure [400 – 800 kPa (4 – 8 kg/cm², 56 – 113 psi)] to the oil hole shown in the illustration, and measure the stroke of the second coast brake piston using wire gauges.

Standard value: 1.5 – 3.0 mm (0.059 – 0.118 in.)

NOTE

Measure the stroke several times and take an average.

(47) If the stroke is out of specification, reinstall the piston and measure the piston stroke again.

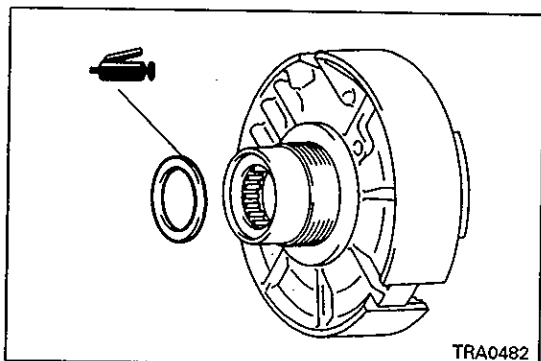

TRA0482

(48) Check that the clutch drum thrust washer is attached to the rear side of the overdrive support.

(49) Apply petrolatum to the race [50.9 mm (2.00 in.) in outer diameter and 36.8 mm (1.45 in.) in inner diameter] and attach it to the rear side of the overdrive support.

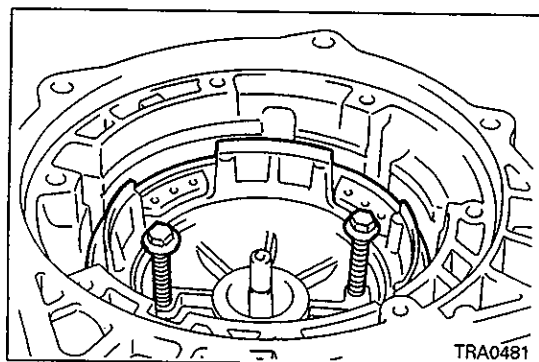

TRA0481

(50) While aligning the oil hole and bolt hole of the overdrive support with the bolt holes in the transmission case using the two overdrive support attaching bolts, insert the overdrive support in the transmission case toward the valve body side.

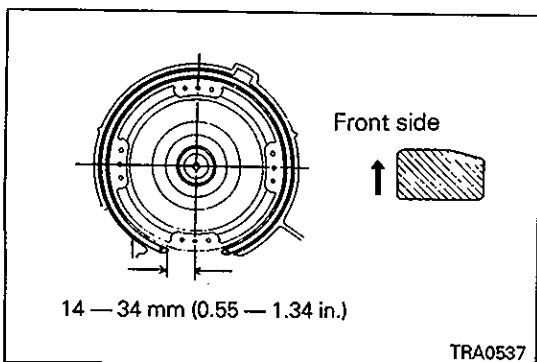

TRA0537

(51) Install the snap ring as illustrated.

Standard value: 14 – 34 mm (0.55 – 1.34 in.)

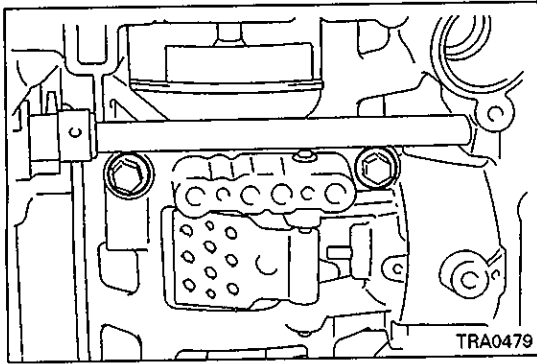

(52) Alternately tighten the two overdrive support attaching bolts uniformly and little by little.

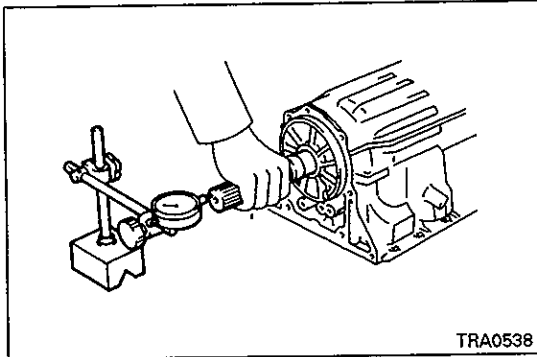

(53) Apply a dial gauge to the end of the output shaft and check its end play.

Standard value: 0.27 – 0.86 mm (0.011 – 0.034 in.)

(54) Check that the output shaft rotates smoothly.

NOTE

Check that the output shaft is not in the parking state.

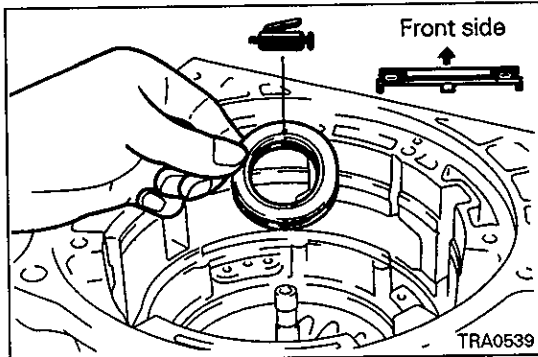

(55) Apply petrolatum to the races [58.8 mm (2.31 in.) in outer diameter and 37.2 mm (1.46 in.) in inner diameter] and bearing [51.1 mm (2.01 in.) in outer diameter and 33.7 mm (1.33 in.) in inner diameter]. Aligning the four bearing lugs with the overdrive support notches, attach the bearing and then the races to the overdrive support.

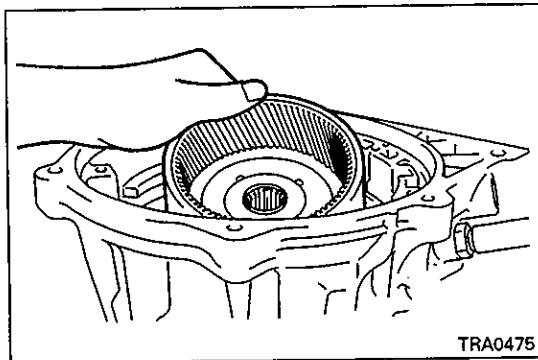

(56) Install the overdrive planetary ring gear.

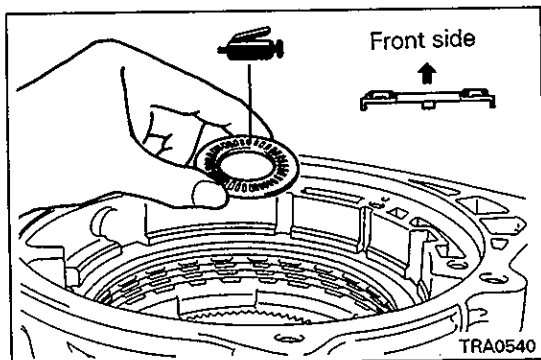

(57) Apply petrolatum to the race [47.8 mm (1.88 in.) in outer diameter and 24.2 mm (0.95 in.) in inner diameter] and bearing [46.8 mm (1.84 in.) in outer diameter and 26.0 mm (1.02 in.) in inner diameter]. Aligning the four bearing lugs with the holes of the ring gear, attach the race and bearing to the gear.

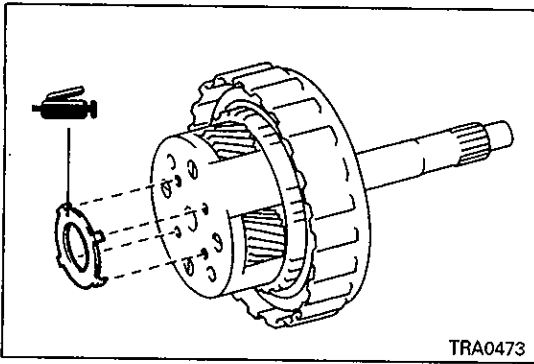

(58) Apply petrolatum to the race [41.8 mm (1.65 in.) in outer diameter and 27.3 mm (1.07 in.) in inner diameter]. Aligning the four race lugs with the holes of the overdrive planetary gear, attach it to the gear.

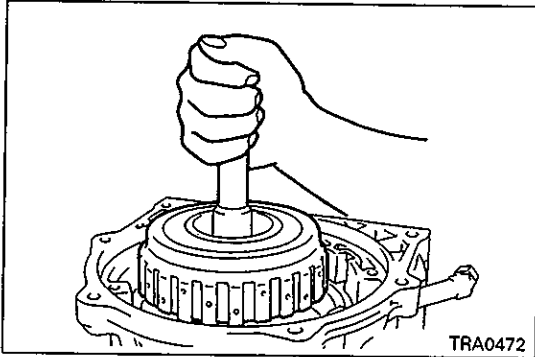

(59) Holding the input shaft, install the overdrive planetary gear assembly and overdrive direct clutch assembly together.

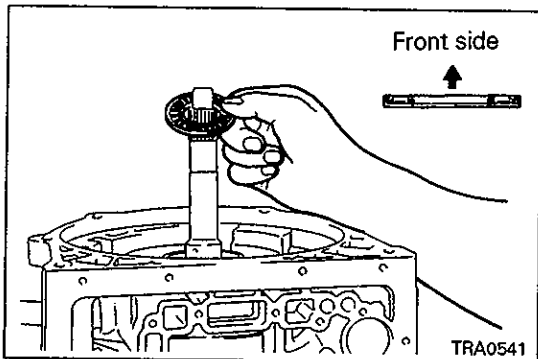

(60) Install the race with bearing [50.2 mm (1.98 in.) in outer diameter and 28.9 mm (1.14 in.) in inner diameter] through the input shaft.

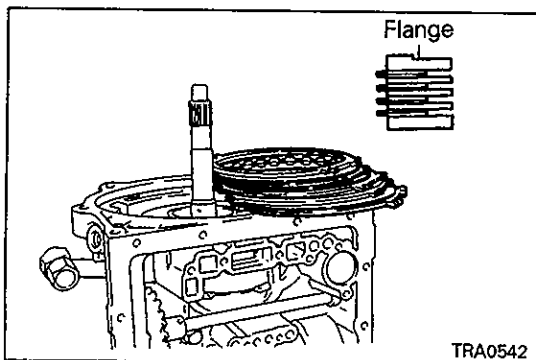

(61) Install one 4.0 mm (0.16 in.) thickness flange in such a way that its chamfer faces the disc side. Install the four discs and three plates alternately. Install the other flange in the illustrated direction.

Caution

- When the 4.0 mm (0.16 in.) flange is used also on the front side, its chamfer must also face the disc side.

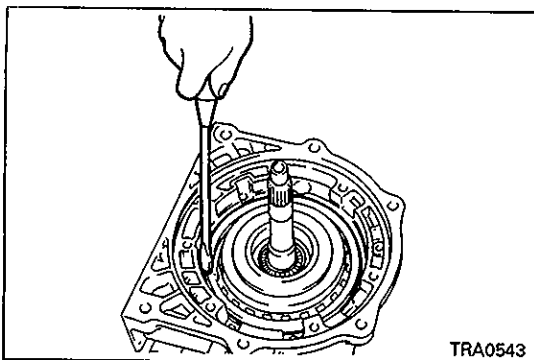

(62) Install the snap ring.

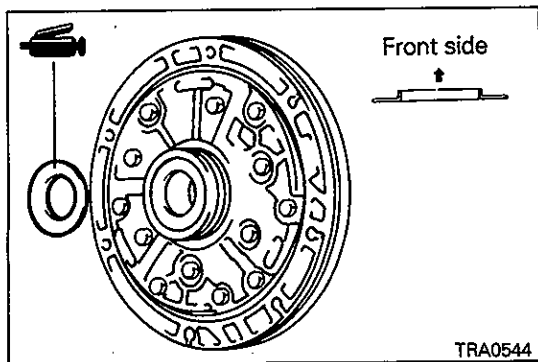

(63) Apply petrolatum to the race [47.3 mm (1.86 in.) in outer diameter and 28.1 mm (1.11 in.) in inner diameter] and attach it to the rear side of the oil pump.

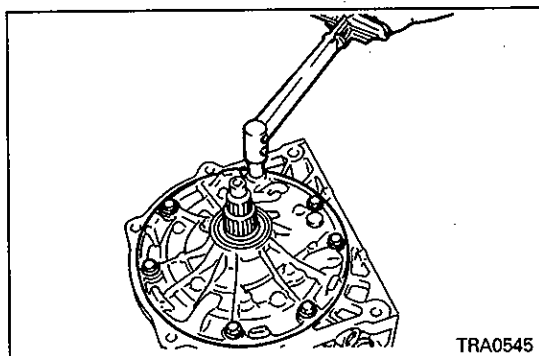

(64) Align the bolt holes in the oil pump with those in the transmission case.

(65) Install the oil pump by hitting at its upper face lightly and uniformly with a plastic hammer. Then, fix it by tightening the seven bolts uniformly and little by little.

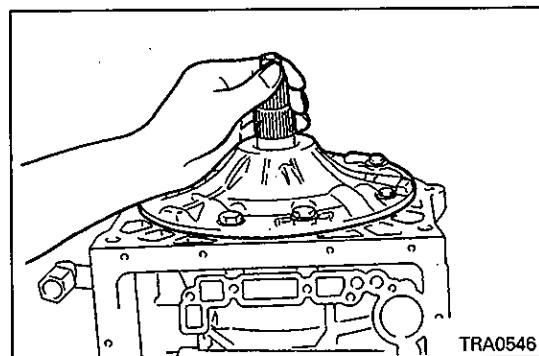

(66) Check that the input shaft rotates smoothly.

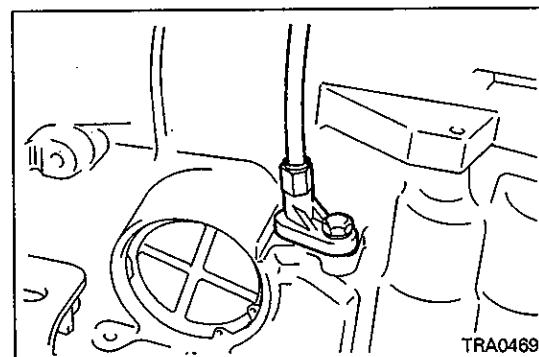

(67) Apply ATF to a new O-ring and attach it to the throttle cable.

(68) Install the throttle cable to the transmission case.

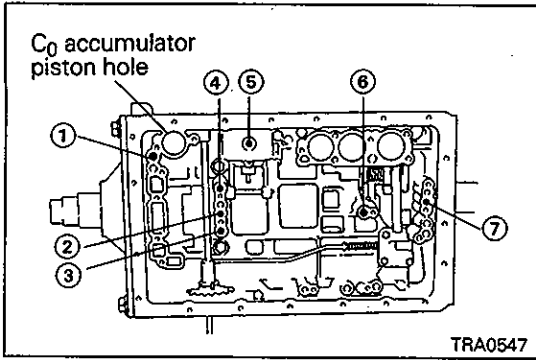

(69) Blow air in each illustrated oil hole to check for operation noise.

- ① Overdrive direct clutch
- ② Direct clutch
- ③ Forward clutch
- ④ Overdrive brake
- ⑤ Second coast brake
- ⑥ Second brake
- ⑦ First & reverse brake

Caution

- **When checking the overdrive direct clutch, close the C₀ accumulator piston hole.**

If no operation noise is recognized, disassemble the structure and check if each part is installed properly.

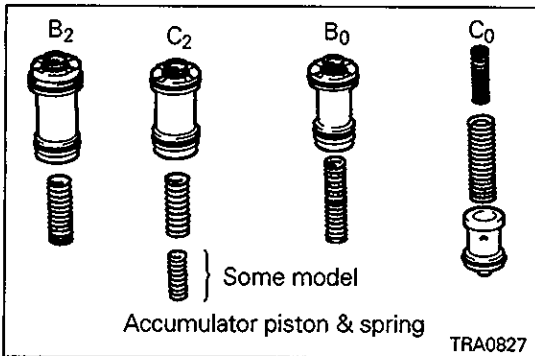

(70) Apply ATF to the new O-rings.

(71) Install the spring, accumulator piston and pin <Up to MODEL 1995>.

Accumulator piston

Dimension		mm (in.)	
Place	Outer diameter	Length	
B ₂	36.9 (1.45)	62.5 (2.461)	
C ₂	36.9 (1.45)	56.6 (2.228)	
B ₀	31.9 (1.26)	52.0 (2.047)	
C ₀	29.9 (1.18)	44.0 (1.732)	

[Reference]

Each piston has an identification code (B₂, C₂, B₀ or C₀), indicating the accumulator to which it is to be installed.

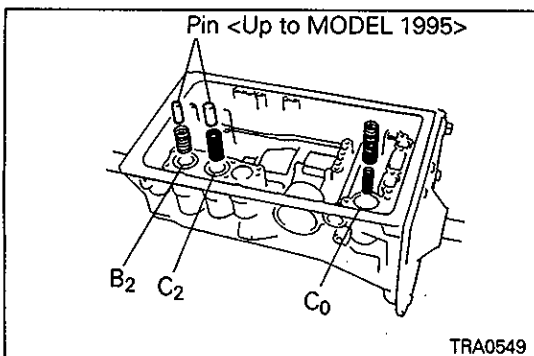

Pin <Up to MODEL 1995>

Dimension		mm (in.)	
Place	Outer diameter	Inner diameter	
B ₂	11.85 – 12.15 (0.467 – 0.478)	35.0 – 35.4 (1.378 – 1.394)	
C ₂	13.55 – 13.85 (0.533 – 0.545)	33.0 – 33.4 (1.299 – 1.315)	

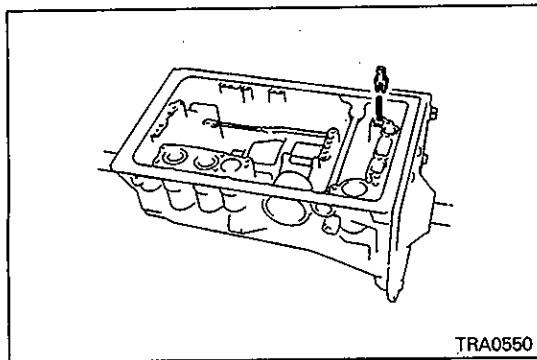

Spring

Place		Dimension	mm (in.)			
			Free height	Outside diameter	Number of loops	Wire diameter
C ₀	Outer spring 1		74.6 (2.937)	20.9 (0.823)	12.3	2.3 (0.091)
	Outer spring 2		46.0 (1.811)	14.0 (0.551)	12.5	2.2 (0.087)
C ₂	Outer spring 4M40*1		22.0 (0.866)	11.9 (0.469)	5.3	1.7 (0.067)
	6G72 <PAJERO/ MONTERO, 200>		24.0 (0.945)	12.0 (0.472)	5.4	1.7 (0.067)
	6G72 <L400>		21.0 (0.827)	10.5 (0.413)	3.9	1.7 (0.067)
	6G74*1		20.0 (0.787)	12.1 (0.476)	4.5	1.7 (0.067)
	6G74, 4M40*2		22.0 (0.866)	12.0 (0.472)	5.3	1.7 (0.067)
C ₂	Inner spring 4M40*1		64.0 (2.520)	20.2 (0.795)	10.3	2.2 (0.087)
	6G74*1		70.2 (2.764)	20.2 (0.795)	10.1	2.3 (0.091)
	Inner spring1 4M40*2		68.5 (2.697)	20.2 (0.795)	9.1	2.2 (0.087)
	6G72		64.0 (2.520)	20.2 (0.795)	10.3	2.2 (0.087)
	6G74*2		64.0 (2.520)	20.2 (0.795)	12.3	2.2 (0.087)
	Inner spring 2 6G72		42.1 (1.657)	14.7 (0.579)	9.25	2.5 (0.098)
	6G74, 4M40*2		42.1 (1.657)	14.7 (0.579)	7.3	2.5 (0.098)
B ₀	Outer spring		14.5 (0.571)	13.0 (0.512)	3.0	2.1 (0.083)
	Inner spring		62.0 (2.441)	16.0 (0.630)	11.9	2.1 (0.083)
B ₂	Outer spring 4M40*1		17.0 (0.669)	12.7 (0.499)	3.3	2.1 (0.083)
	4M40*2		20.0 (0.787)	14.0 (0.551)	5.2	1.9 (0.075)
	6G72		23.0 (0.901)	14.0 (0.551)	4.9	2.0 (0.079)
	6G74*1		22.0 (0.866)	14.0 (0.551)	5.2	1.9 (0.075)
	6G74*2		19.0 (0.748)	14.0 (0.551)	5.7	2.0 (0.079)

NOTE

*1: Except 98 – model PAJERO/MONTERO

*2: 98 – model PAJERO/MONTERO

Place		Dimension	Free height	Outside diameter	Number of loops	Wire diameter
B ₂	Inner spring 4M40*1		70.5 (2.776)	19.9 (0.783)	10.4	2.4 (0.094)
	4M40*2		72.6 (2.858)	19.9 (0.783)	12.5	2.8 (0.110)
	6G72		70.5 (2.776)	19.7 (0.776)	12.9	2.7 (0.106)
	6G74*1		72.6 (2.858)	19.9 (0.783)	12.5	2.8 (0.110)
	6G74*2		75.3 (2.964)	20.0 (0.787)	14.3	2.7 (0.106)

NOTE

*1: Except 98 – model PAJERO/MONTERO

*2: 98 – model PAJERO/MONTERO

(72) Install the spring and check ball body.

(73) Align the groove of the manual valve with the pin of the manual valve lever.

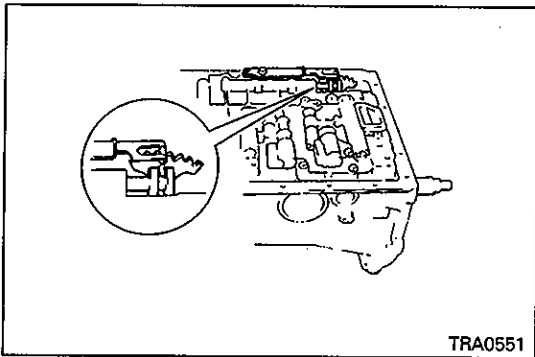

Intentionally blank

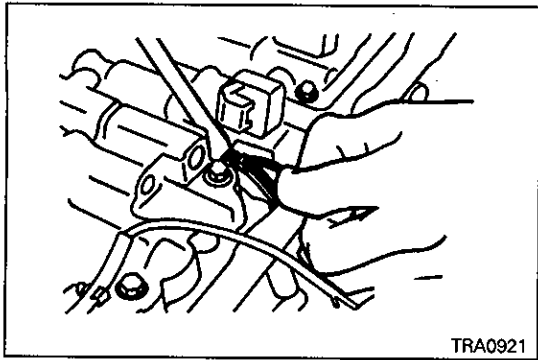

- (74) Install the throttle cable nipple to the throttle cam.
- (75) Check that the spring and collar of the accumulator piston are installed on the valve body side.

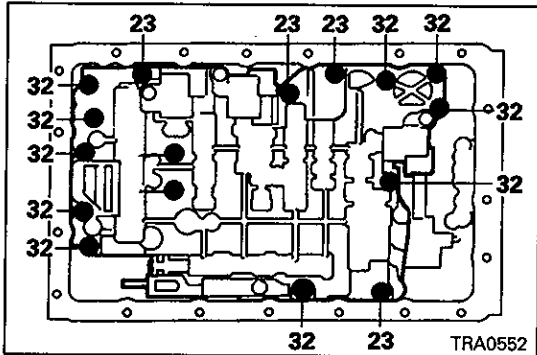

- (76) Install the valve body by tightening the 16 bolts uniformly step by step. (The values in the illustration denote the shank length of each bolt.)

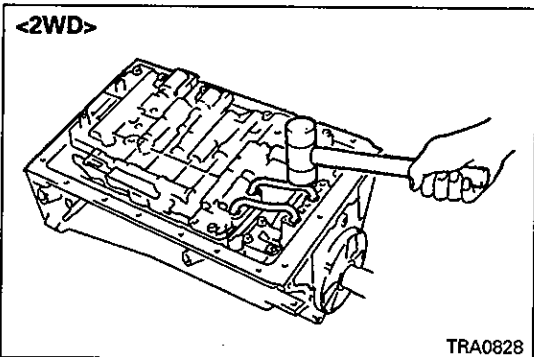

- (77) Using a plastic hammer, install the brake tube.

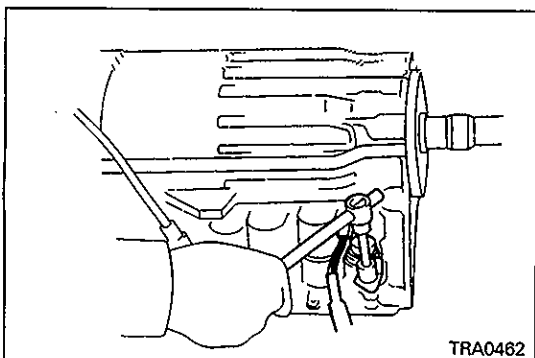
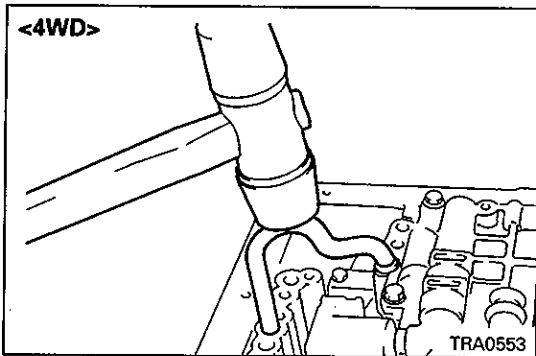

- (78) Apply ATF to a new O-ring.
- (79) Insert the transmission wire in the transmission case and secure it with the stopper plate.

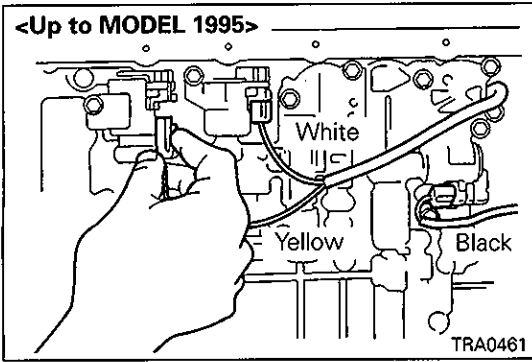

(80) Install the three connectors to the transmission solenoid.

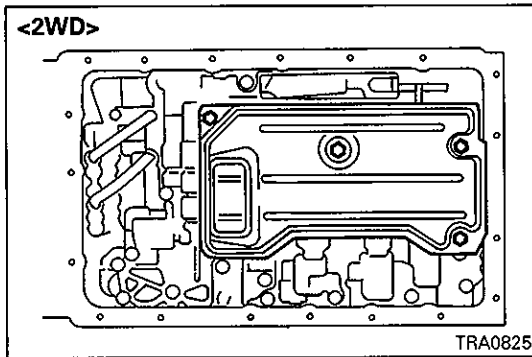
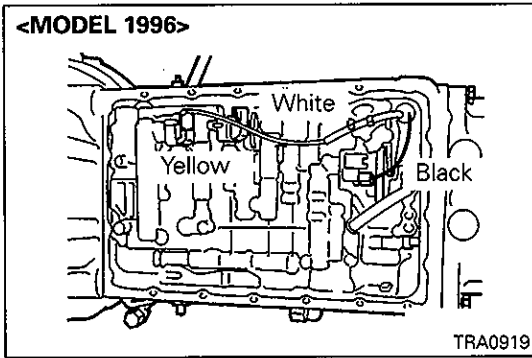

(81) Install the oil screen assembly using the 4 bolts. <2WD>

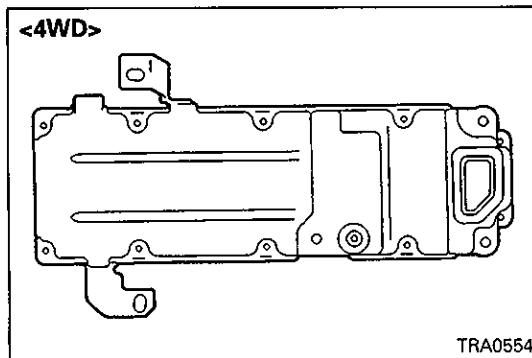

(82) With a scraper and wire brush and by air blow, clean the gasket mounting surface of the oil strainer. <4WD>

(83) Attach the two new gaskets, one to the spacer and the other to the oil screen. <4WD>

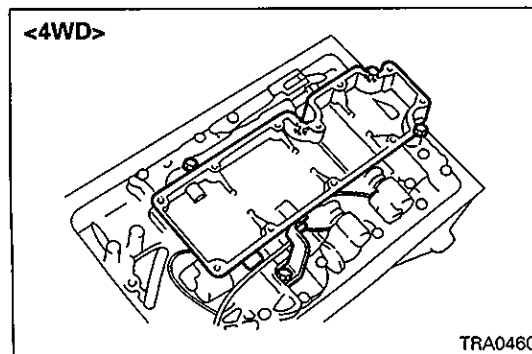

(84) Using five bolts, install the spacer and oil screen. <4WD>

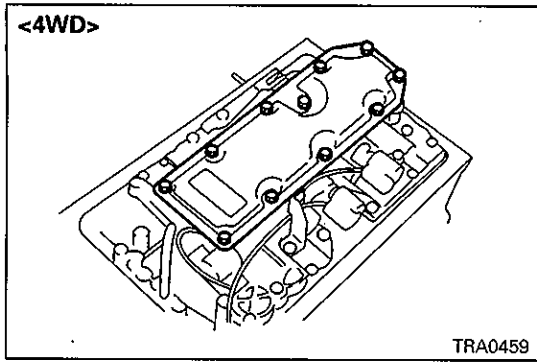

(85) After setting a new gasket, install the oil screen assembly using the 11 bolts. <4WD>

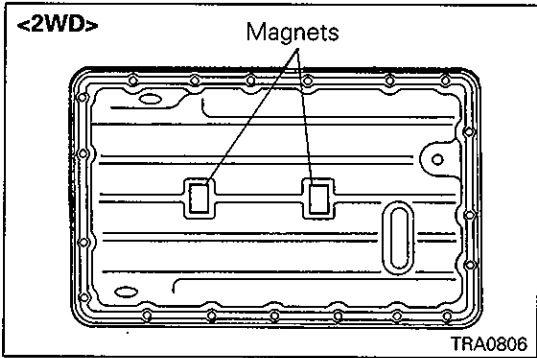

(86) Using a scraper and wire brush, remove sealer sticking on the transmission case and oil pan. Then, wash off oil with detergent.

Caution

- When cleaning and washing the transmission case, the valve body side must be kept down.

(87) Wash the magnets and attach them as illustrated.

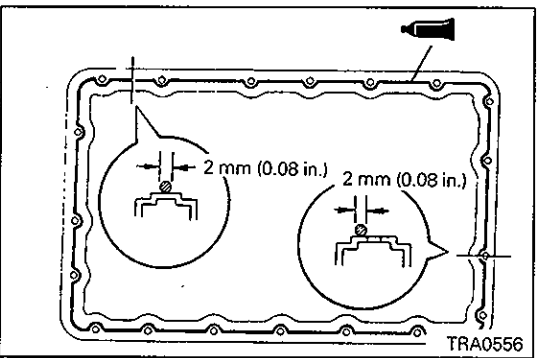
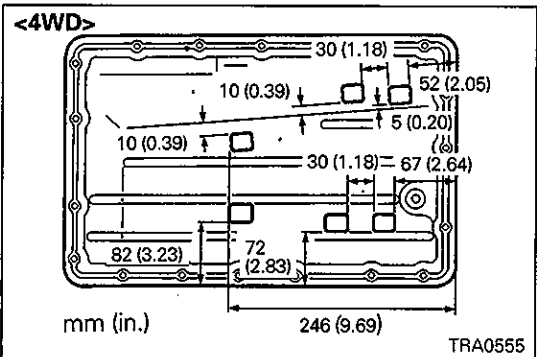

(88) Apply sealer to the oil pan and install it to the transmission case.

Specified sealant: Threebond Seal Packing 1281

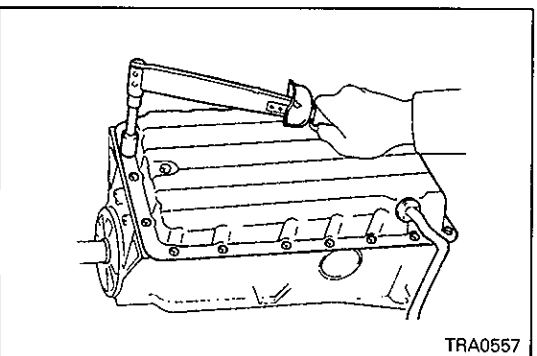

(89) Tighten the 19 bolts uniformly and step by step.

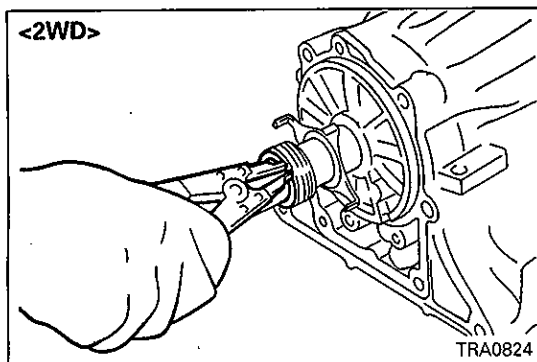

(90) Install the key and then the sensor rotor to the output shaft.

<2WD>

(91) Install the speedometer drive gear and the snap ring.

<2WD>

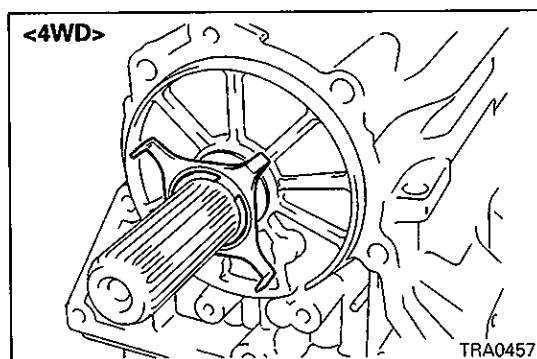

(92) Install the key and then the sensor rotor to the output shaft.

<4WD>

(93) Install the snap ring. <4WD>

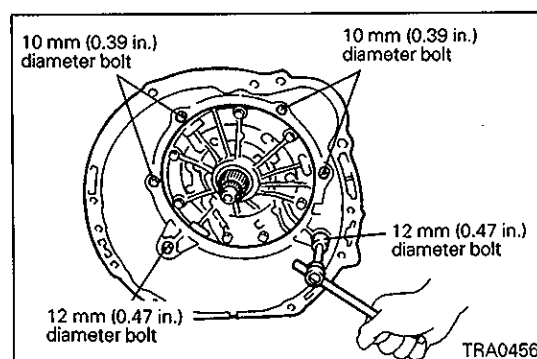

(94) Using the 6 bolts, install the housing to the transmission case.

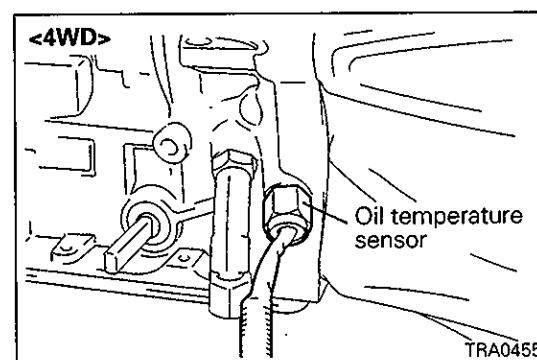

(95) Apply ATF to a new O-ring and attach it to the oil temperature sensor. <4WD>

(96) Install the oil temperature sensor to the transmission case.

<4WD>

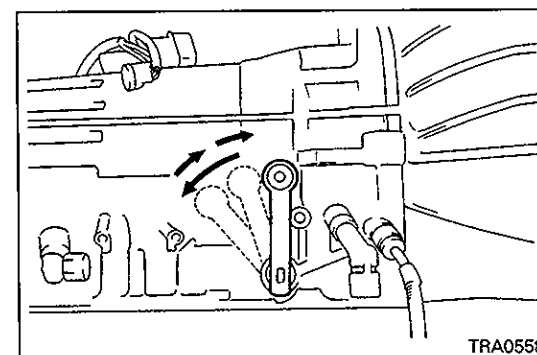

(97) Set the control shaft lever to the N range position by rotating the manual control shaft fully backward and then returning it by two notches.

(98) Insert park/neutral position switch in the manual valve shaft and tentatively tighten the set bolt.

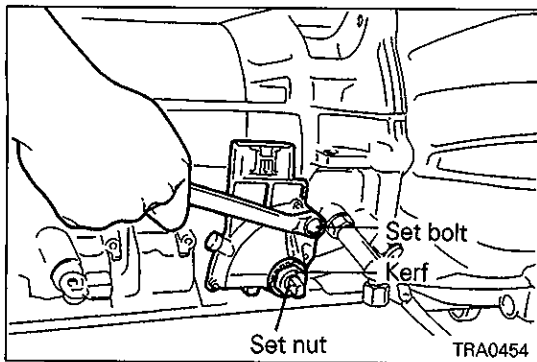

- (99) Install the new gasket and lock washer and tighten the set nut.
- (100) Aligning the kerf in the switch with the neutral reference line, tighten the set bolt firmly.
- (101) Bend lock washer tabs.

Caution

- **Two or more lugs must be bent.**

- (102) Install the control shaft lever.

- (103) Install the harness connector bracket and throttle cable clamp.

- (104) Apply ATF to a new O-ring and attach it to the oil filler tube. Install the tube to the oil pan.

- (105) Install the oil level gauge.

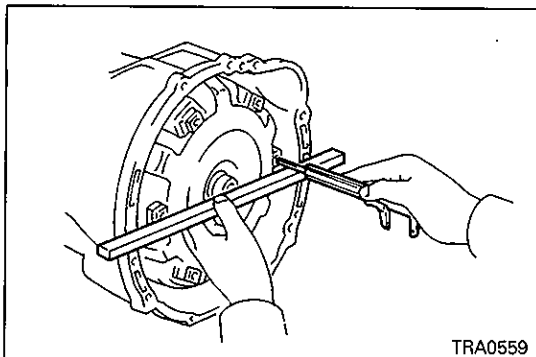

- (106) Aligning the notch of the torque converter with the inner lug of the oil pump, install the torque converter.

- (107) Check the illustrated dimension of the installed torque converter.

Standard value: 31.1 mm (1.22 in.) or more

5. OIL PUMP

DISASSEMBLY AND REASSEMBLY

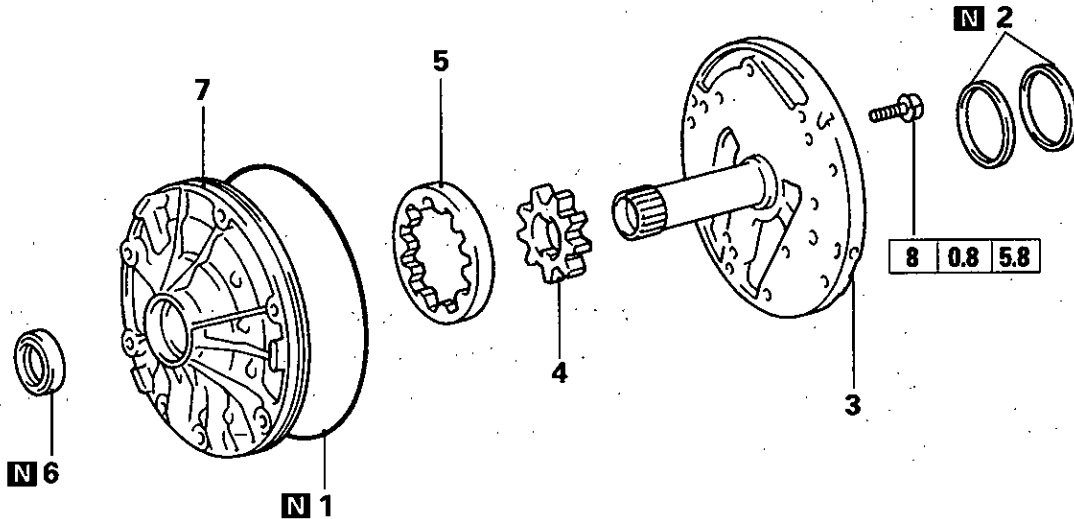

Disassembly steps

- 1. O-ring
- ↗B 2. Seal ring
- 3. Stator shaft
- ↔A↔ 4. Drive gear
- ↔A↔ 5. Driven gear
- ↗A 6. Oil seal
- 7. Oil pump body

 Lubricate all internal parts with automatic transmission fluid during reassembly.

TRA0560

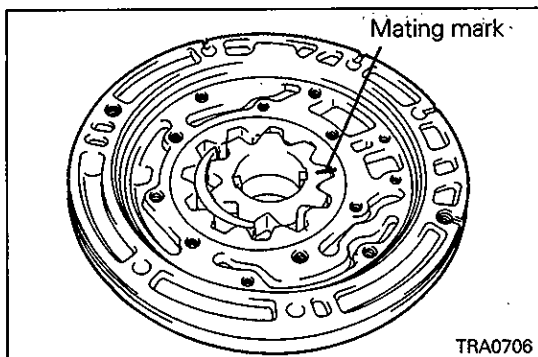

TRA0706

DISASSEMBLY SERVICE POINT

↔A↔ DRIVE GEAR / DRIVEN GEAR REMOVAL

- (1) Put mating marks on the side of removed gears for their reassembly in correct direction. (Use a felt marker or equivalent.)

INSPECTION

DRIVE GEAR AND DRIVEN GEAR

Body Clearance

- (1) Measure the clearance between the driven gear and oil pump body with a feeler gauge while pushing the driven gear strongly toward the opposite side.

Standard value: 0.07 – 0.15 mm (0.003 – 0.006 in.)

Limit: 0.30 mm (0.012 in.)

If the limit is exceeded, replace the driven gear or oil pump body.

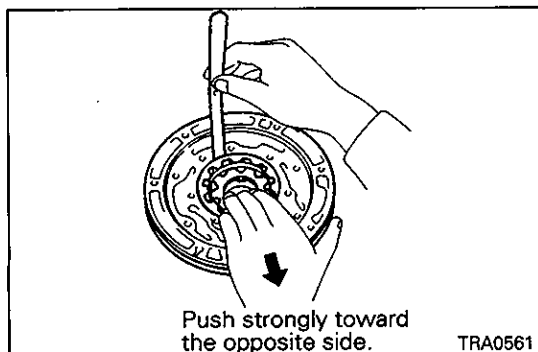

Push strongly toward the opposite side.

TRA0561

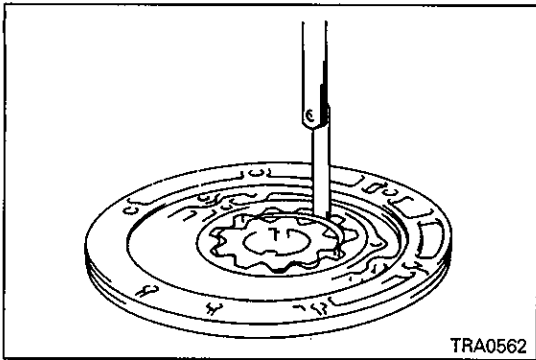
**Tip Clearance**

- (1) Using a feeler gauge, measure the crescent-to-driven gear clearance.

Standard value: 0.11 – 0.14 mm (0.004 – 0.006 in.)

Limit: 0.30 mm (0.012 in.)

If the limit is exceeded, replace the driven gear or oil pump body.

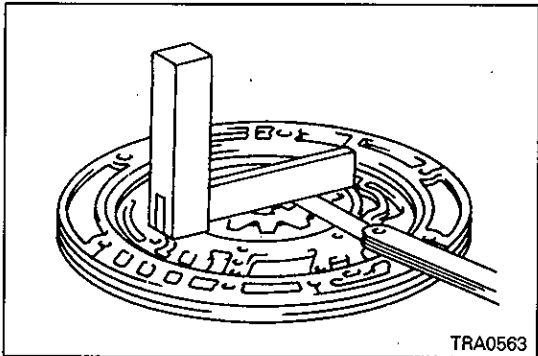
**Side Clearance**

- (1) Using a square and feeler gauge, measure the side clearance of the gears with respect to the stator shaft mounting surface.

Standard value: 0.02 – 0.05 mm (0.0008 – 0.0020 in.)

Limit: 0.30 mm (0.012 in.)

If the limit is exceeded, replace the drive gear, driven gear or oil pump body.

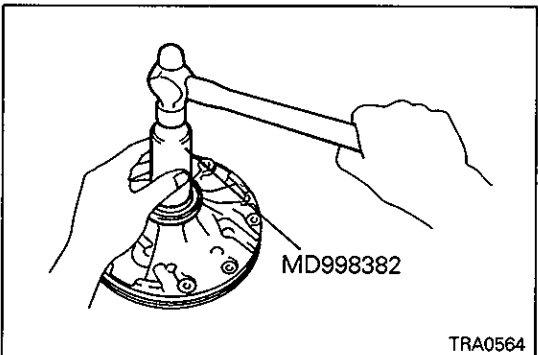
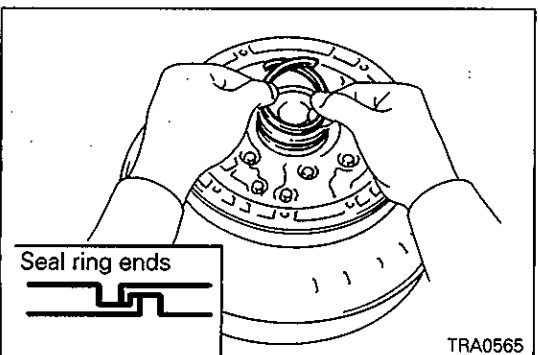
**REASSEMBLY SERVICE POINT****▶◀ OIL SEAL INSTALLATION****▶◀ SEAL RING INSTALLATION**

6. OVERDRIVE PLANETARY GEAR AND OVERDRIVE DIRECT CLUTCH DISASSEMBLY AND REASSEMBLY

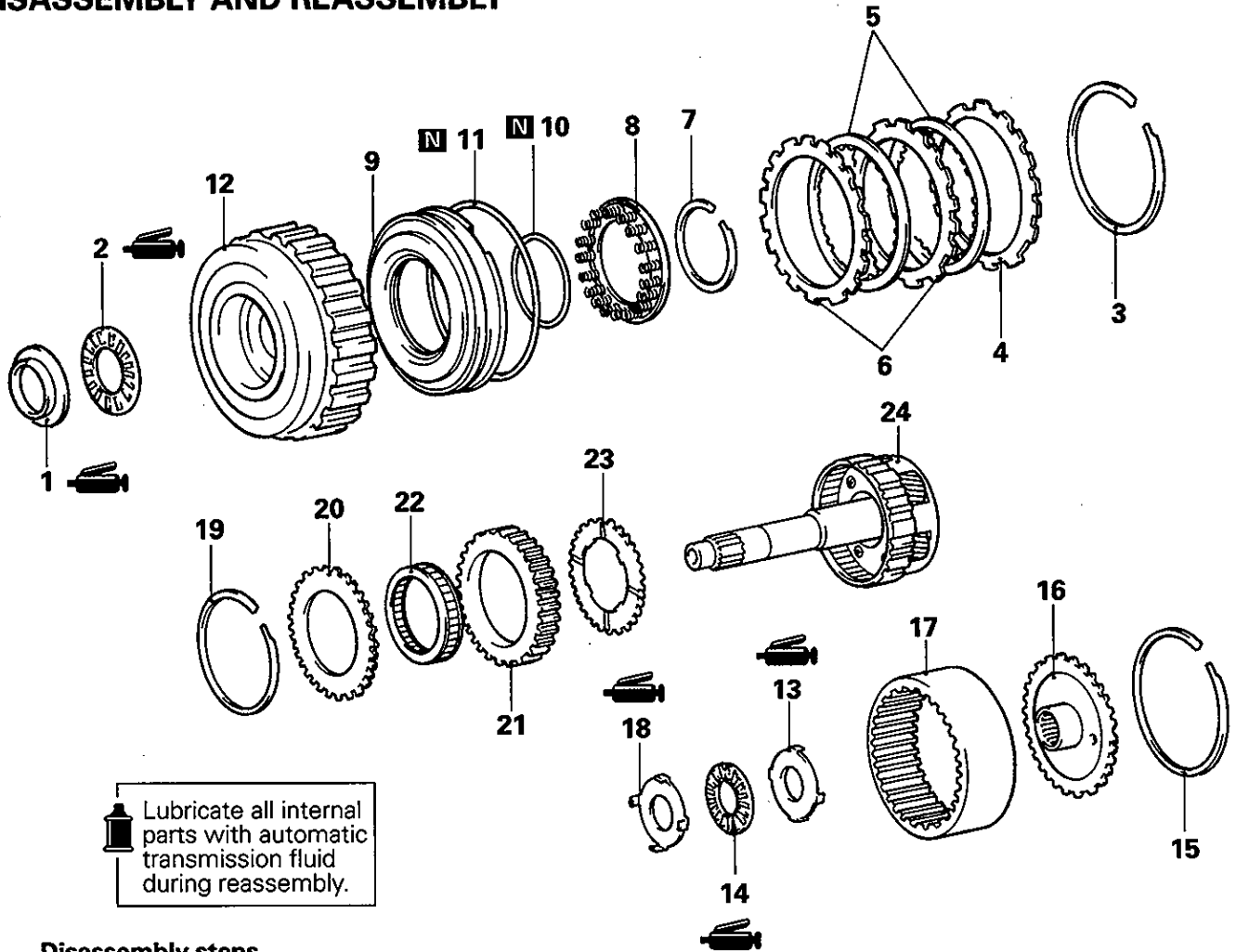

Disassembly steps

- 1. Thrust race
- 2. Thrust bearing
- 3. Snap ring
- ▶D▶ 4. Clutch flange
- 5. Clutch disc
- 6. Clutch plate
- ◀A▶▶C▶ 7. Snap ring
- 8. Return spring assembly
- 9. Overdrive direct clutch piston
- 10. O-ring
- 11. O-ring
- 12. Overdrive direct clutch drum
- 13. Thrust race
- 14. Thrust bearing
- 15. Snap ring
- 16. Overdrive planetary ring gear flange
- 17. Overdrive planetary ring gear
- 18. Thrust race
- 19. Snap ring
- 20. Retaining plate
- 21. One-way clutch outer race
- ▶B▶▶ 22. Overdrive one-way clutch
- ▶A▶▶ 23. Overdrive planetary gear thrust washer No.3
- 24. Overdrive planetary gear assembly

TRA0566

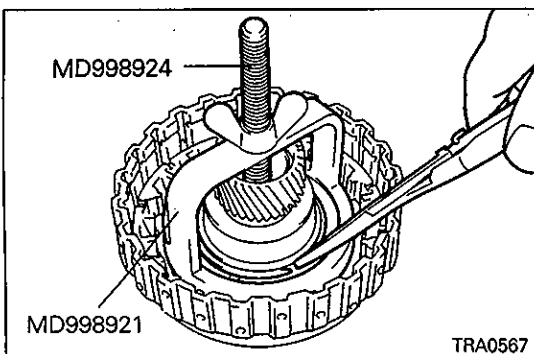

DISASSEMBLY SERVICE POINTS

◀A▶ **SNAP RING REMOVAL**

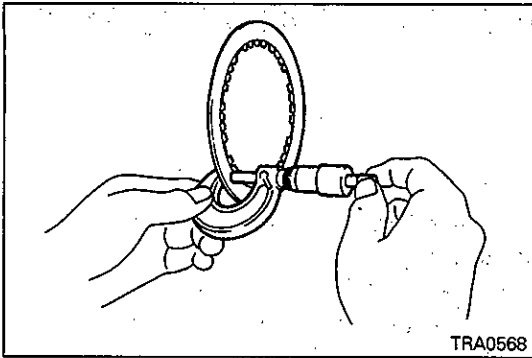

INSPECTION

OVERDRIVE DIRECT CLUTCH DISC

- (1) Using a micrometer, measure the thickness of the clutch disc.

Limit: 1.84 mm (0.072 in.)

NOTE

The thickness must be measured at two or three points. Compare the average value with the limit.

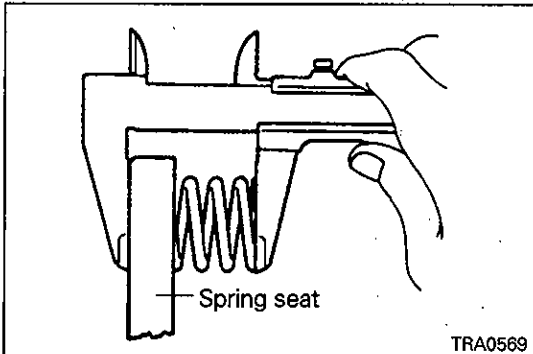

RETURN SPRING ASSEMBLY

- (1) Measure the free length of the spring including the spring seat.

Standard value: Approx. 15.8 mm (0.62 in.)

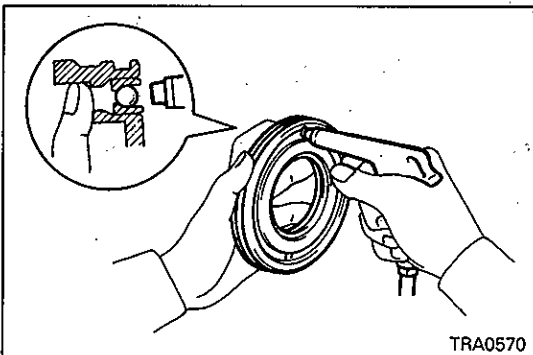

OVERDRIVE DIRECT CLUTCH PISTON

- (1) Check that the check ball is free by shaking the piston.
- (2) Check that the valve does not leak by applying low-pressure compressed air.

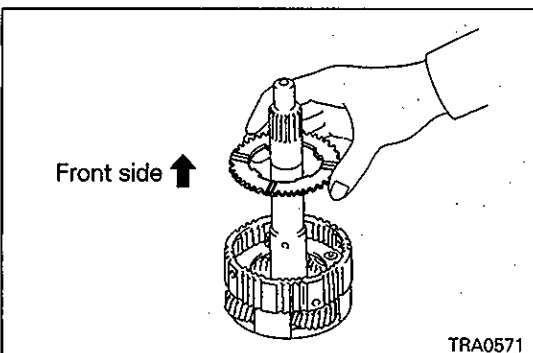

REASSEMBLY SERVICE POINTS

◆A◆ OVERDRIVE PLANETARY GEAR THRUST WASHER NO.3 INSTALLATION

- (1) Install the thrust washer so that its oil groove is oriented to the front side.

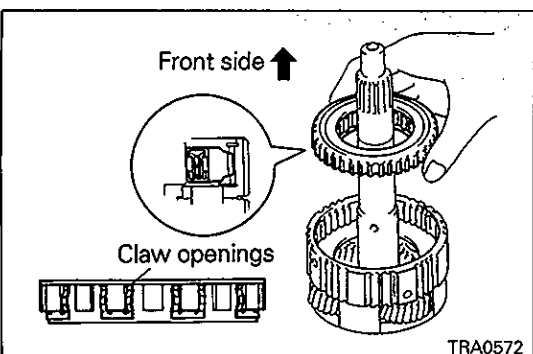

◆B◆ OVERDRIVE ONE-WAY CLUTCH INSTALLATION

- (1) Install the clutch so that its claw openings are oriented to the front side as illustrated.

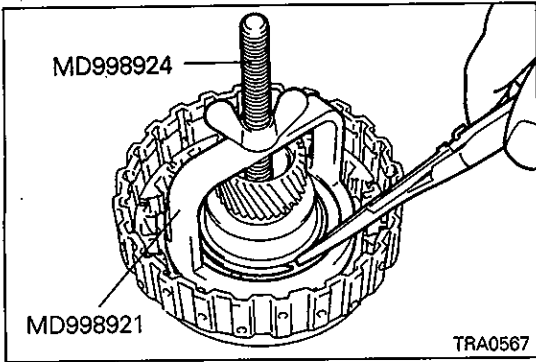

▶C◀ SNAP RING INSTALLATION

Caution

- Be sure the end gap of the snap ring is not aligned with the stopper of the spring seat.

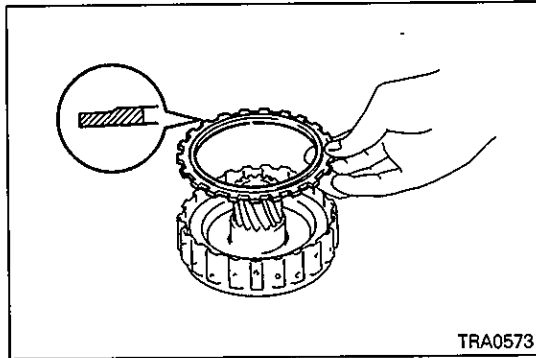

▶D◀ CLUTCH FLANGE INSTALLATION

- (1) Install the clutch flange to the overdrive direct clutch drum so that the flange's convex side faces up as illustrated.

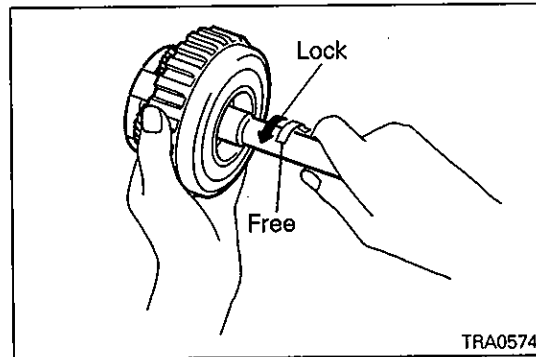

INSPECTION

OPERATION OF ONE-WAY CLUTCH

- (1) While holding the overdrive direct clutch drum, turn the input shaft clockwise to see that the shaft turns smoothly and turn it counterclockwise to see that the shaft is locked.

NOTE

- (1) If the shaft turns or locks in both directions, replace the one-way clutch.
- (2) If the shaft turns counterclockwise while it doesn't turn clockwise, the one-way clutch may have been assembled in the reverse direction.

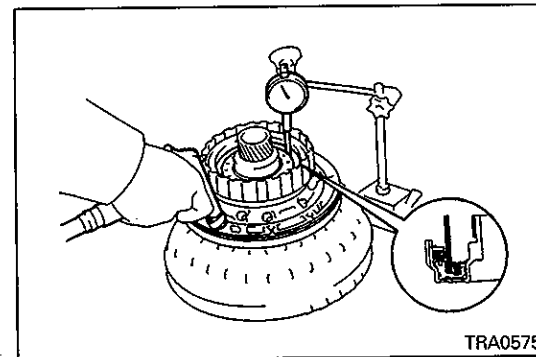

OVERDRIVE DIRECT CLUTCH PISTON STROKE

- (1) Install the oil pump to the torque converter. Install the overdrive direct clutch assembly to the oil pump.
- (2) Using a dial gauge, measure the piston stroke by applying compressed air (400 – 800 kPa, 4 – 8 kg/cm², 57 – 113 psi) into the oil hole of the oil pump as shown and then releasing the air.

Standard value: 1.85 – 2.15 mm (0.073 – 0.085 in.)

If the stroke is out of this range, replace the clutch flange with an appropriate one so that the stroke becomes within this range.

NOTE

When selecting the flange, aim at the center of the range.

[Available flange]

Identification code	16	17	18	19	20	21
Thickness mm (in.)	3.6 (0.142)	3.5 (0.138)	3.4 (0.134)	3.3 (0.130)	3.2 (0.126)	3.1 (0.122)

NOTES

7. OVERDRIVE SUPPORT DISASSEMBLY AND REASSEMBLY

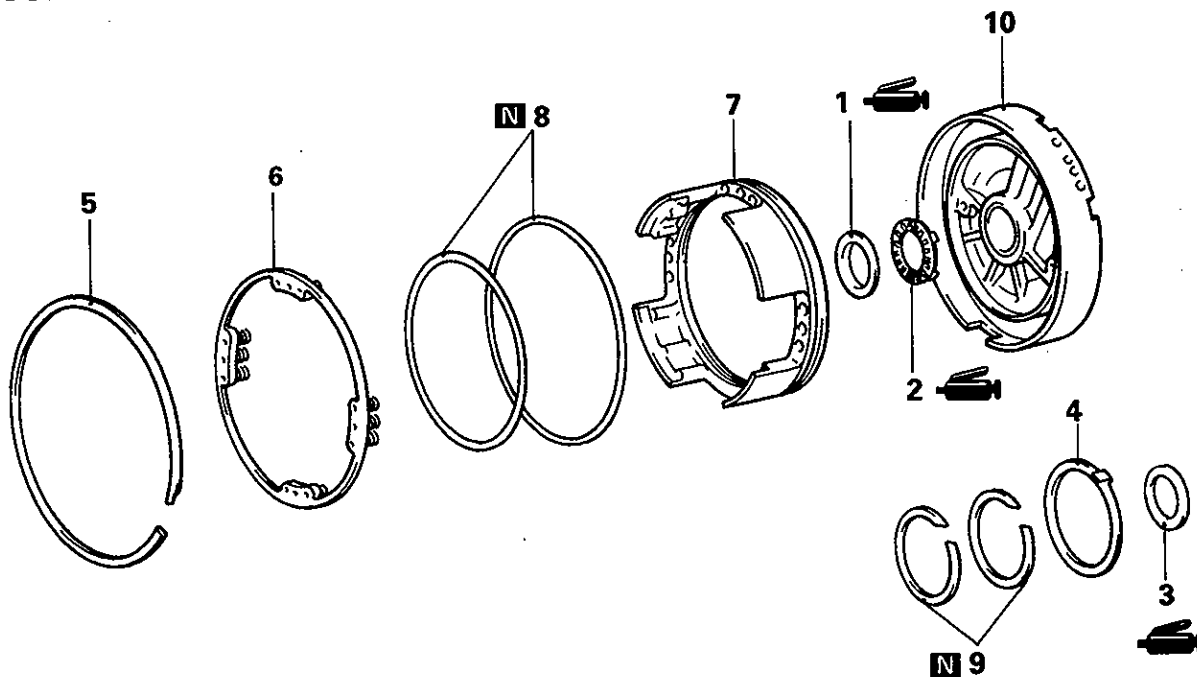

Disassembly steps

1. Thrust race
2. Thrust bearing
3. Thrust race
4. Clutch drum thrust washer
5. Snap ring
6. Return spring assembly
7. Overdrive brake piston
8. O-ring
9. Seal ring
10. Overdrive support assembly

 Lubricate all internal parts with automatic transmission fluid during reassembly.

TRA0576

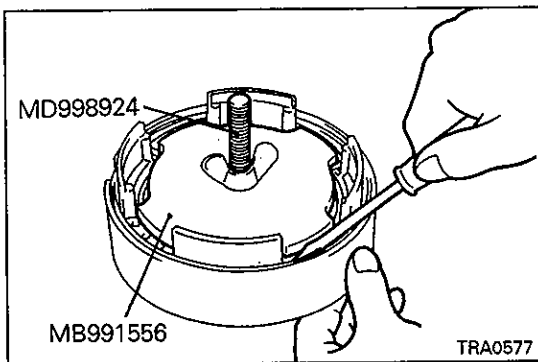

DISASSEMBLY SERVICE POINTS

 **SNAP RING REMOVAL**

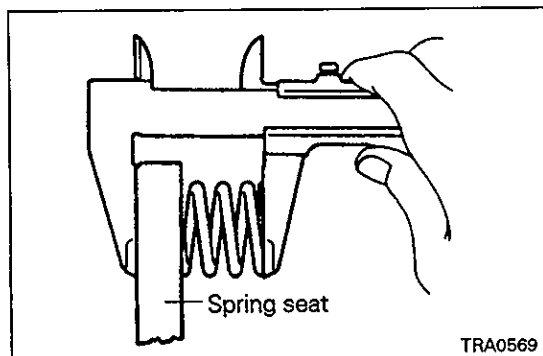

INSPECTION

RETURN SPRING ASSEMBLY

(1) Measure the free length of the spring including the spring seat.

Standard value: Approx. 18.6 mm (0.73 in.)

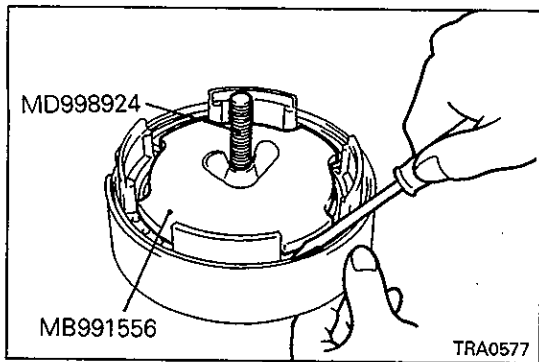

REASSEMBLY SERVICE POINTS

▶◀ SNAP RING INSTALLATION

Caution

- Be sure the end gap of the snap ring is not aligned with the cutout of the support.
- Set the support in such a way that its central convex portion doesn't touch the workbench.

8. DIRECT CLUTCH DISASSEMBLY AND REASSEMBLY

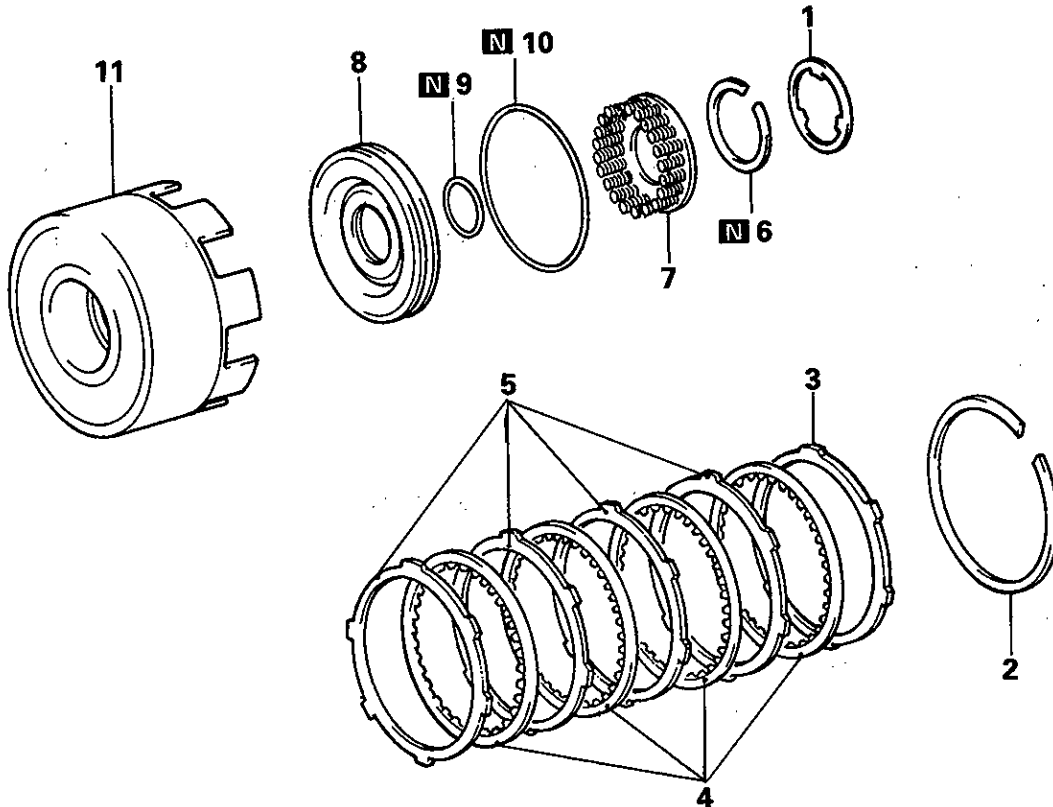

Disassembly steps

1. Thrust washer No.2
- ↻C↻ 2. Snap ring
- ↻B↻ 3. Clutch flange
4. Clutch disc
5. Clutch plate
- ↻A↻ ↻A↻ 6. Snap ring
7. Return spring assembly
8. Direct clutch piston
9. O-ring
10. O-ring
11. Direct clutch drum

 Lubricate all internal parts with automatic transmission fluid during reassembly.

TRA0578

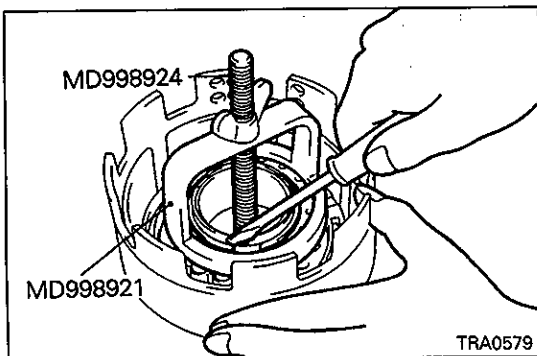

DISASSEMBLY SERVICE POINTS

↻A↻ **SNAP RING REMOVAL**

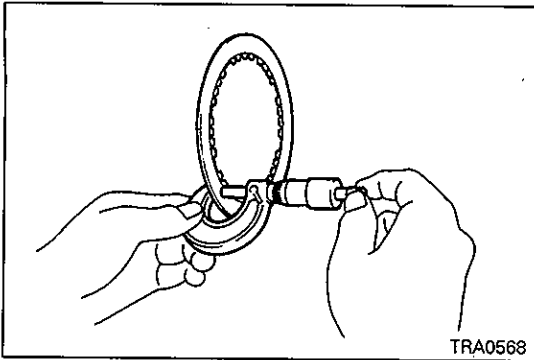
**INSPECTION****DIRECT CLUTCH DISC**

- (1) Using a micrometer, measure the thickness of the clutch disc.

Limit: 1.84 mm (0.072 in.)

NOTE

The thickness must be measured at two or three points. Compare the average value with the limit.

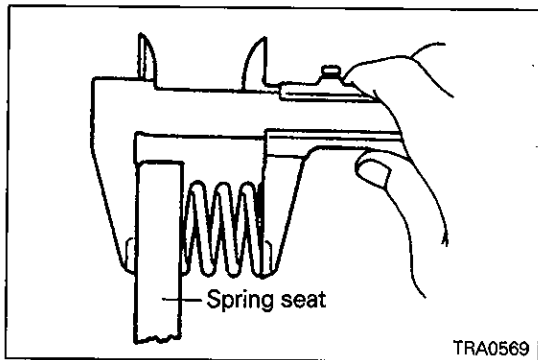
**RETURN SPRING ASSEMBLY**

- (1) Measure the free length of the spring including the spring seat.

Standard value: Approx. 19.8 mm (0.78 in.)

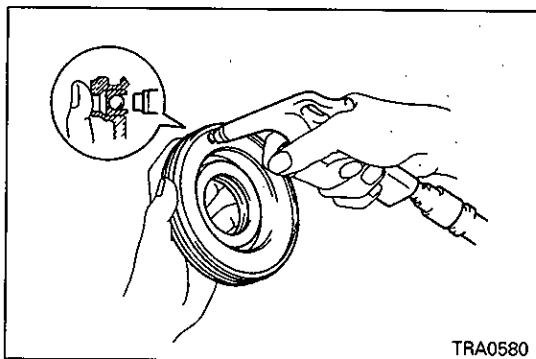
**DIRECT CLUTCH PISTON**

- (1) Check that the check ball is free by shaking the piston.
- (2) Check that the valve does not leak by applying low-pressure compressed air.

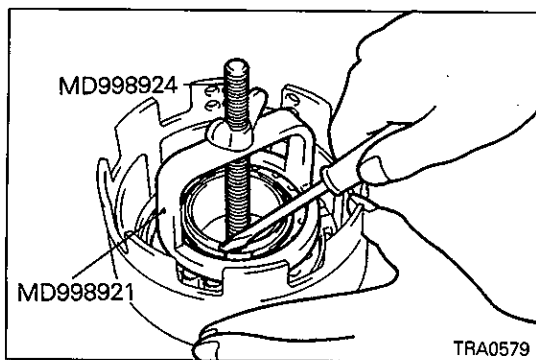
**REASSEMBLY SERVICE POINTS****▶A◀ SNAP RING INSTALLATION****Caution**

- Be sure the end gap of the snap ring is not aligned with the stopper of the spring seat.

▶B◀ CLUTCH FLANGE INSTALLATION

- (1) Install the clutch flange to the direct clutch drum so that the flange's convex side is oriented to the rear side.

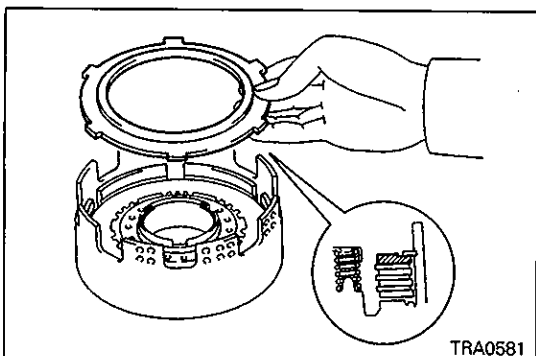

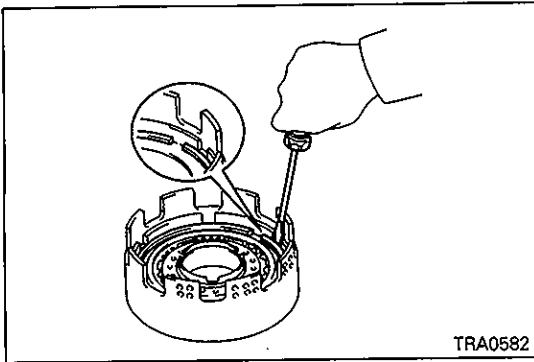

TRA0582

▶◀ SNAP RING INSTALLATION

- (1) Install the snap ring so that the end gap of the snap ring is not aligned with the inner cutout of the direct clutch drum.

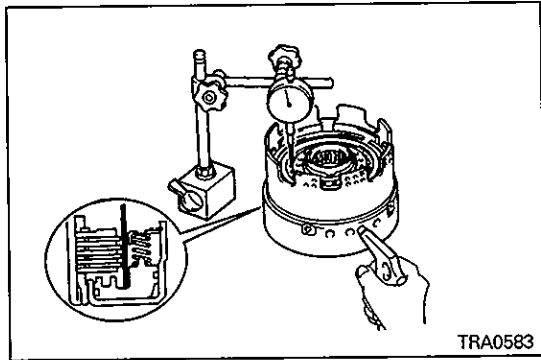

TRA0583

**INSPECTION AFTER REASSEMBLY
DIRECT CLUTCH PISTON STROKE**

- (1) Install the direct clutch to the overdrive support assembly.
- (2) Using a dial gauge, measure the piston stroke by applying compressed air (400 – 800 kPa, 4 – 8 kg/cm², 57 – 113 psi) into the oil hole of the overdrive support as shown and then releasing the air.

Standard value: 1.37 – 1.67 mm (0.054 – 0.066 in.)

If the stroke is out of this range, replace the clutch flange with an appropriate one so that the stroke becomes within this range.

NOTE

When selecting the flange, aim at the center of the range.

[Available flanges]

Identifica- tion code	33	32	31	30	29	28	27	34
Thick- ness mm (in.)	3.0 (0.118)	3.1 (0.122)	3.2 (0.126)	3.3 (0.130)	3.4 (0.134)	3.5 (0.138)	3.6 (0.142)	3.7 (0.146)

NOTES

9. FORWARD CLUTCH

DISASSEMBLY AND REASSEMBLY

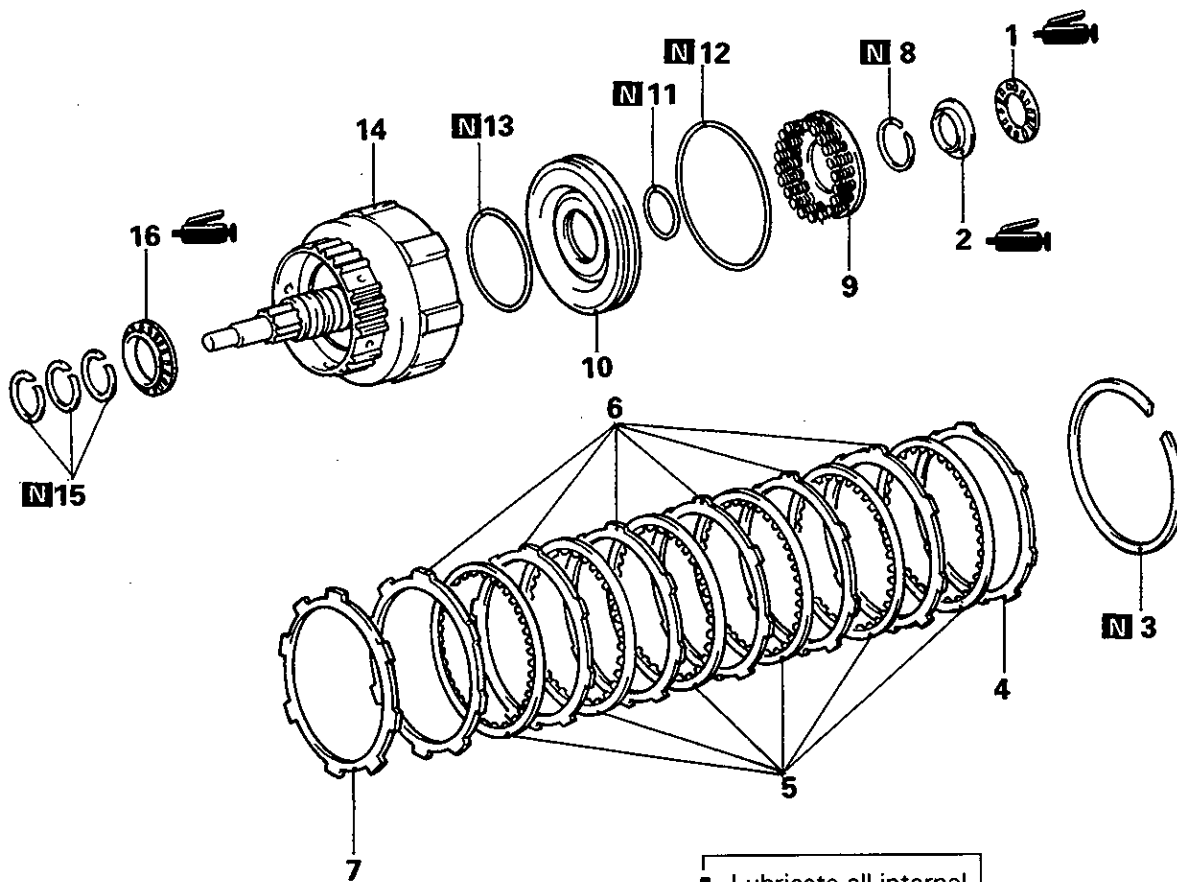

Disassembly steps

1. Thrust bearing
2. Thrust race
- ▶D▶ 3. Snap ring
- ▶C▶ 4. Clutch flange
5. Clutch disc
6. Clutch plate
- ▶B▶ 7. Cushion plate
- ◀A▶▶A▶ 8. Snap ring
9. Return spring assembly
10. Forward clutch piston
11. O-ring
12. O-ring
13. O-ring
14. Forward clutch drum
15. Seal ring
16. Thrust bearing

 Lubricate all internal parts with automatic transmission fluid during reassembly.

No. of clutch discs/plates

	Clutch disc	Clutch plate
4M40, 6G72	5	5
6G74	6	6

TRA0584

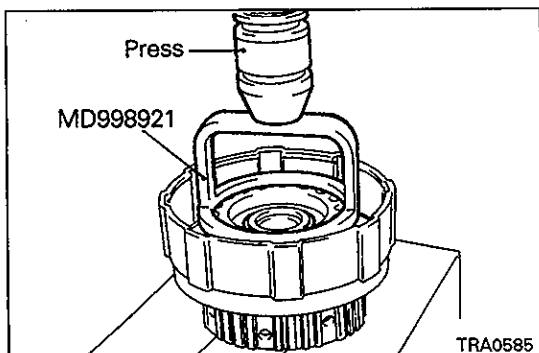

DISASSEMBLY SERVICE POINTS

◀A▶ SNAP RING REMOVAL

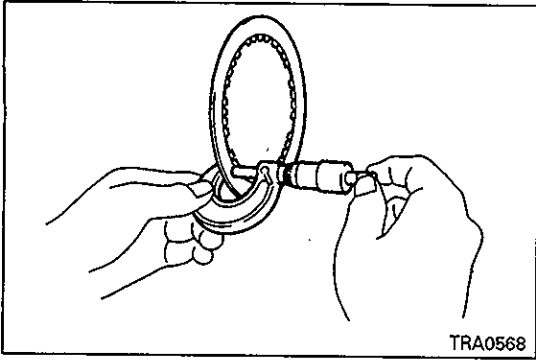
**INSPECTION****FORWARD CLUTCH DISC**

- (1) Using a micrometer, measure the thickness of the clutch disc.

Limit: 1.84 mm (0.072 in.)

NOTE

The thickness must be measured at two or three points. Compare the average value with the limit.

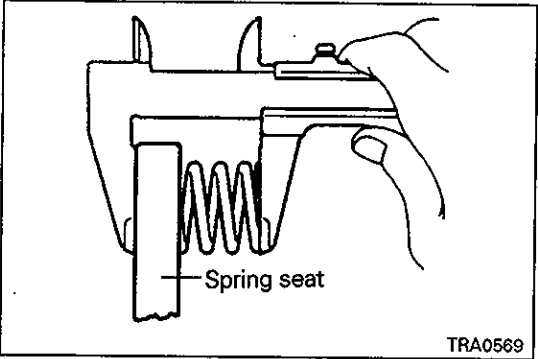
**RETURN SPRING ASSEMBLY**

- (1) Measure the free length of the spring including the spring seat.

Standard value: Approx. 11.55 mm (0.455 in.)

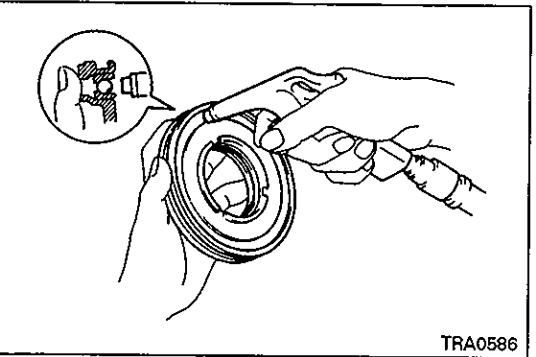
**FORWARD CLUTCH PISTON**

- (1) Check that the check ball is free by shaking the piston.
- (2) Check that the valve does not leak by applying low-pressure compressed air.

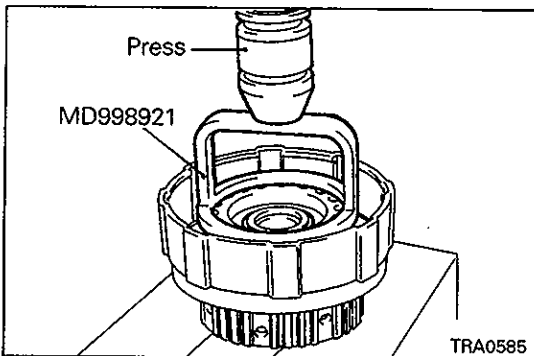
**REASSEMBLY SERVICE POINTS****◆A◆ SNAP RING INSTALLATION****Caution**

- Be sure the end gap of the snap ring is not aligned with the stopper of the spring seat.

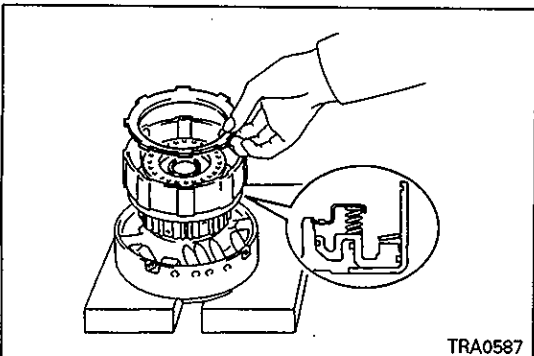
**◆B◆ CUSHION PLATE INSTALLATION**

- (1) Install the cushion plate to the forward clutch drum so that its convex side is oriented to the piston side.

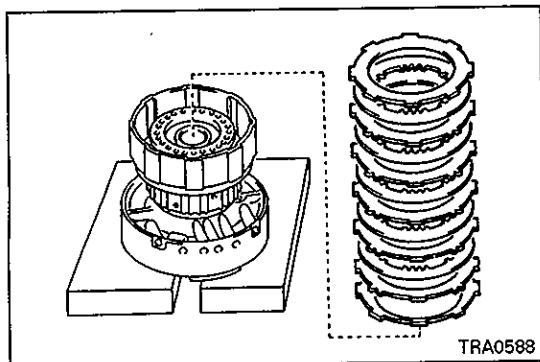

◆C◆ CLUTCH FLANGE INSTALLATION

- (1) Install the clutch flange to the forward clutch drum so that the flange's chamfer is oriented to the disc side.

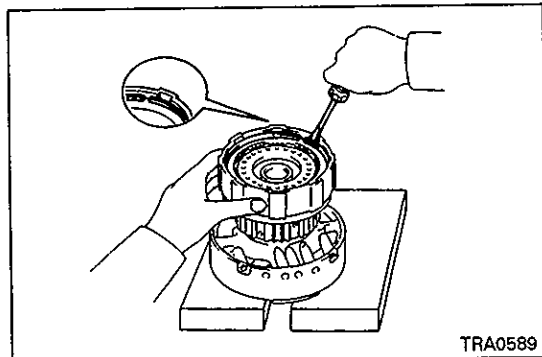

◆D◆ SNAP RING INSTALLATION

- (1) Install the snap ring so that the end gap of the snap ring is not aligned with the inner cutout of the direct clutch drum.

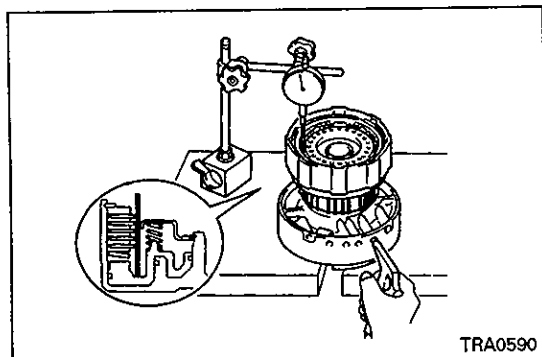

INSPECTION AFTER REASSEMBLY FORWARD CLUTCH PISTON STROKE

- (1) Install the forward clutch to the overdrive support assembly.
- (2) Using a dial gauge, measure the piston stroke by applying compressed air (400 – 800 kPa, 4 – 8 kg/cm², 57 – 113 psi) into the oil hole of the overdrive support as shown and then releasing the air.

Standard value:

2.65 – 3.98 mm (0.104 – 0.157 in.)	4M40, 6G72
2.90 – 4.29 mm (0.114 – 0.169 in.)	6G74

NOTES

10.FRONT PLANETARY GEAR DISASSEMBLY AND REASSEMBLY

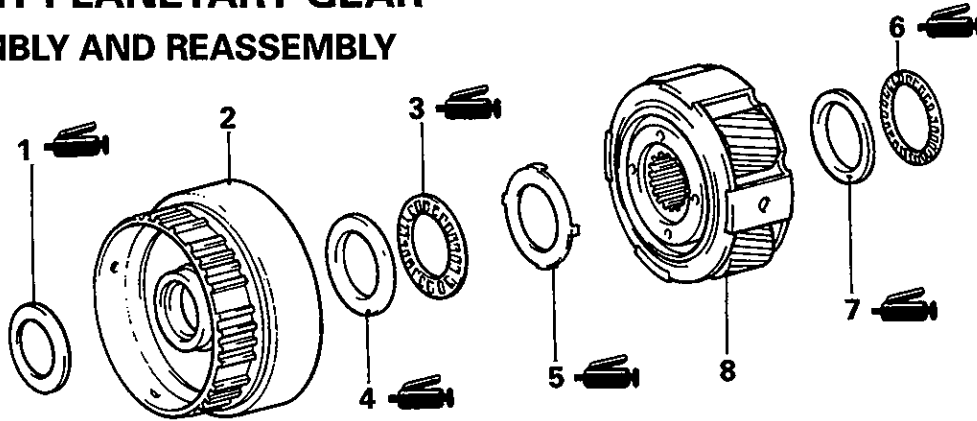

Disassembly steps

- 1. Thrust race
- 2. Front planetary ring gear assembly
- ▶C◀ 3. Thrust bearing
- ▶C◀ 4. Thrust race
- ▶B◀ 5. Thrust race
- ▶A◀ 6. Thrust bearing
- ▶A◀ 7. Thrust race
- 8. Front planetary gear assembly

 Lubricate all internal parts with automatic transmission fluid during reassembly.

TRA0591

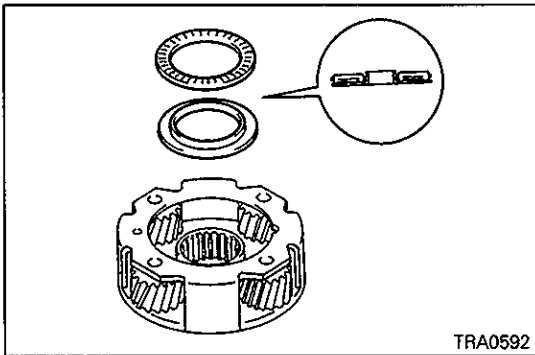

REASSEMBLY SERVICE POINTS

▶A◀ **THRUST RACE / THRUST BEARING INSTALLATION**

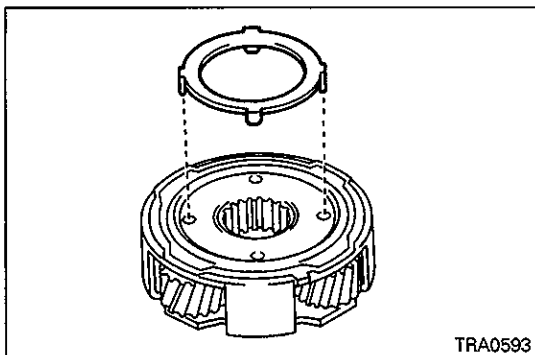

▶B◀ **THRUST RACE INSTALLATION**

- (1) Install the thrust race to the planetary gear assembly while aligning its claws with the holes of the front planetary gear.

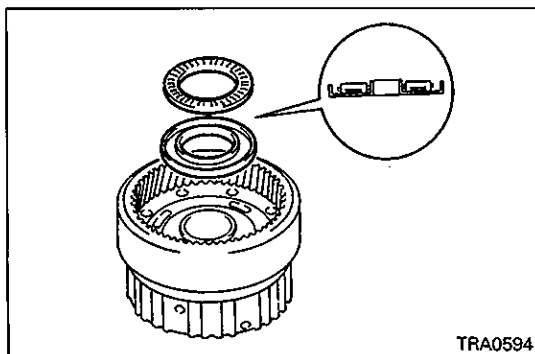



▶C◀ **THRUST RACE / THRUST BEARING INSTALLATION**

NOTES

11. PLANETARY SUN GEAR AND ONE-WAY CLUTCH NO.1

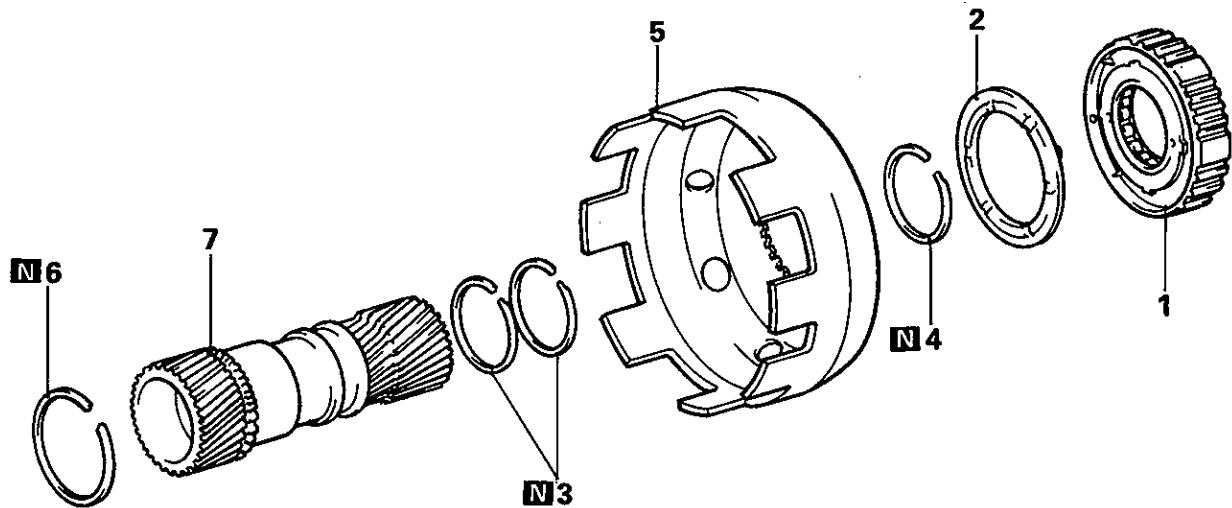
DISASSEMBLY AND REASSEMBLY



 Lubricate all internal parts with automatic transmission fluid during reassembly.

Disassembly steps

- ◆C◆ 1. One-way clutch assembly
- ◆B◆ 2. One-way clutch thrust washer No.1
- ◆A◆ 3. Seal ring
- 4. Snap ring
- 5. Sun gear input drum
- 6. Snap ring
- 7. Planetary sun gear

TRA0595

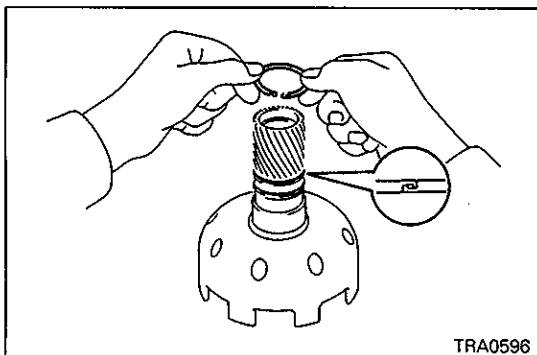

TRA0596

REASSEMBLY SERVICE POINTS

◆A◆ SEAL RING INSTALLATION

- (1) Don't open the seal ring wider than necessary. Be careful not to bend the claws.

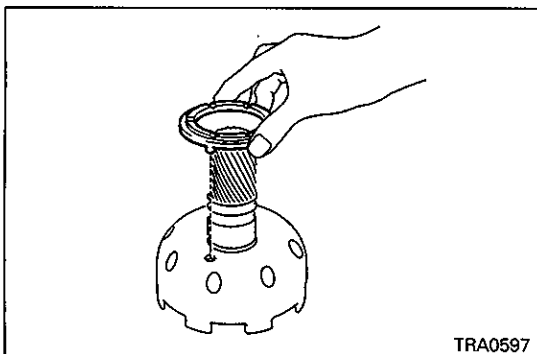

TRA0597

◆B◆ ONE-WAY CLUTCH THRUST WASHER NO.1 INSTALLATION

- (1) Install the thrust washer to the sun gear input drum while aligning its convex with the hole of the drum.

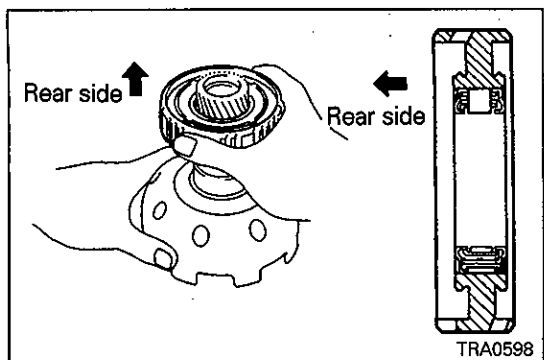

⇄ ONE-WAY CLUTCH ASSEMBLY INSTALLATION

- (1) Install the one-way clutch assembly to the planetary sun gear in the direction shown in the illustration.

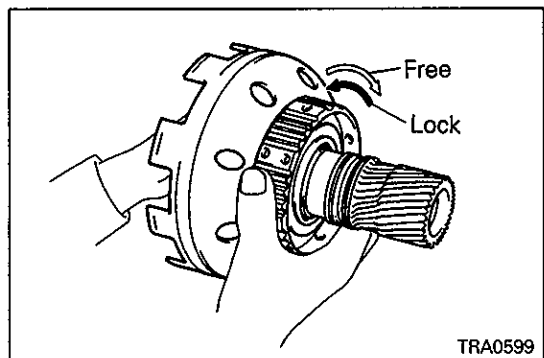

INSPECTION AFTER REASSEMBLY

OPERATION OF ONE-WAY CLUTCH

- (1) While holding planetary sun gear, turn the one-way clutch clockwise to see that the clutch turns smoothly and turn it counterclockwise to see that the clutch is locked.

NOTE

- (1) If the one-way clutch turns or locks in both directions, replace the one-way clutch.
- (2) If the one-way clutch turns counterclockwise while it doesn't turn clockwise, the one-way clutch may have been installed in the reverse direction.

12. SECOND BRAKE DISASSEMBLY AND REASSEMBLY

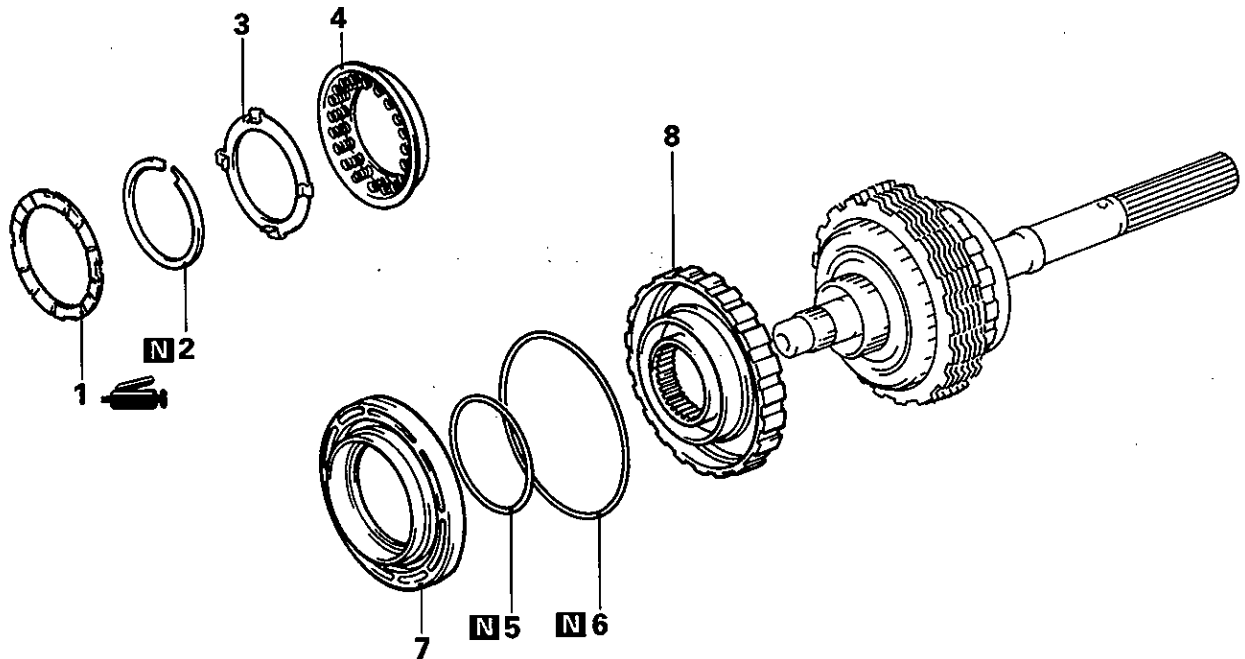

Disassembly steps

- 1. One-way clutch thrust washer No.2
- ◊A◊ ◊A◊ 2. Snap ring
- 3. Return spring seat
- 4. Return spring assembly
- 5. O-ring
- 6. O-ring
- ◊B◊ 7. Second brake piston
- 8. Second brake drum assembly

 Lubricate all internal parts with automatic transmission fluid during reassembly.

TRA0600

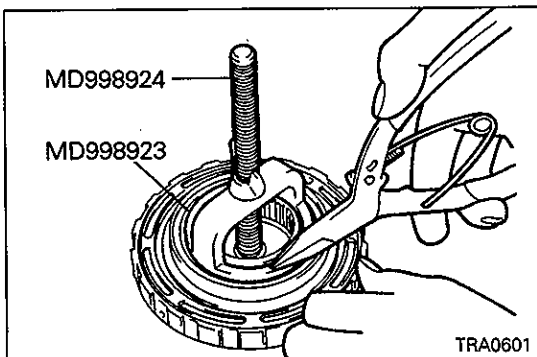

DISASSEMBLY SERVICE POINTS

◊A◊ SNAP RING REMOVAL

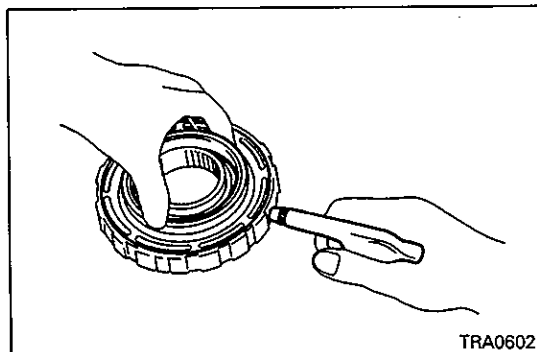

◊B◊ SECOND BRAKE PISTON REMOVAL

- (1) With the second brake piston held, blow air into the second brake drum through the oil hole to remove the second brake piston.

Caution

- Do not blow air suddenly because the piston may be tipped and become hard to remove.

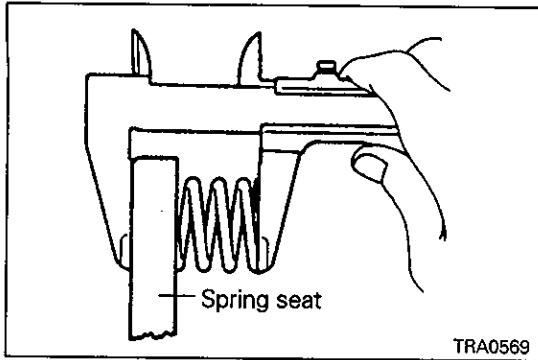
**INSPECTION****RETURN SPRING ASSEMBLY**

- (1) Measure the free length of the spring including the spring seat.

Standard value: Approx. 15.05 mm (0.593 in.)

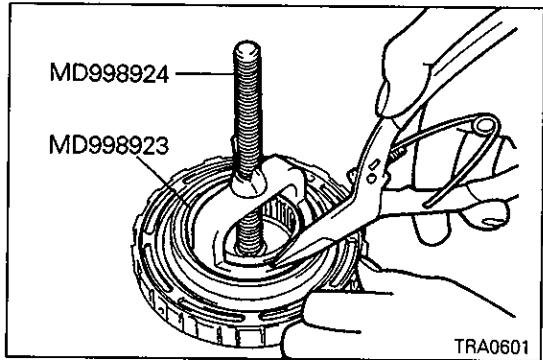
**REASSEMBLY SERVICE POINTS****◆◆ SNAP RING INSTALLATION****Caution**

- Be sure the end gap of the snap ring is not aligned with the stopper of the spring seat.

13. REAR PLANETARY GEAR, OUTPUT SHAFT AND FIRST & REVERSE BRAKE BRAKE

DISASSEMBLY AND REASSEMBLY

 Lubricate all internal parts with automatic transmission fluid during reassembly.

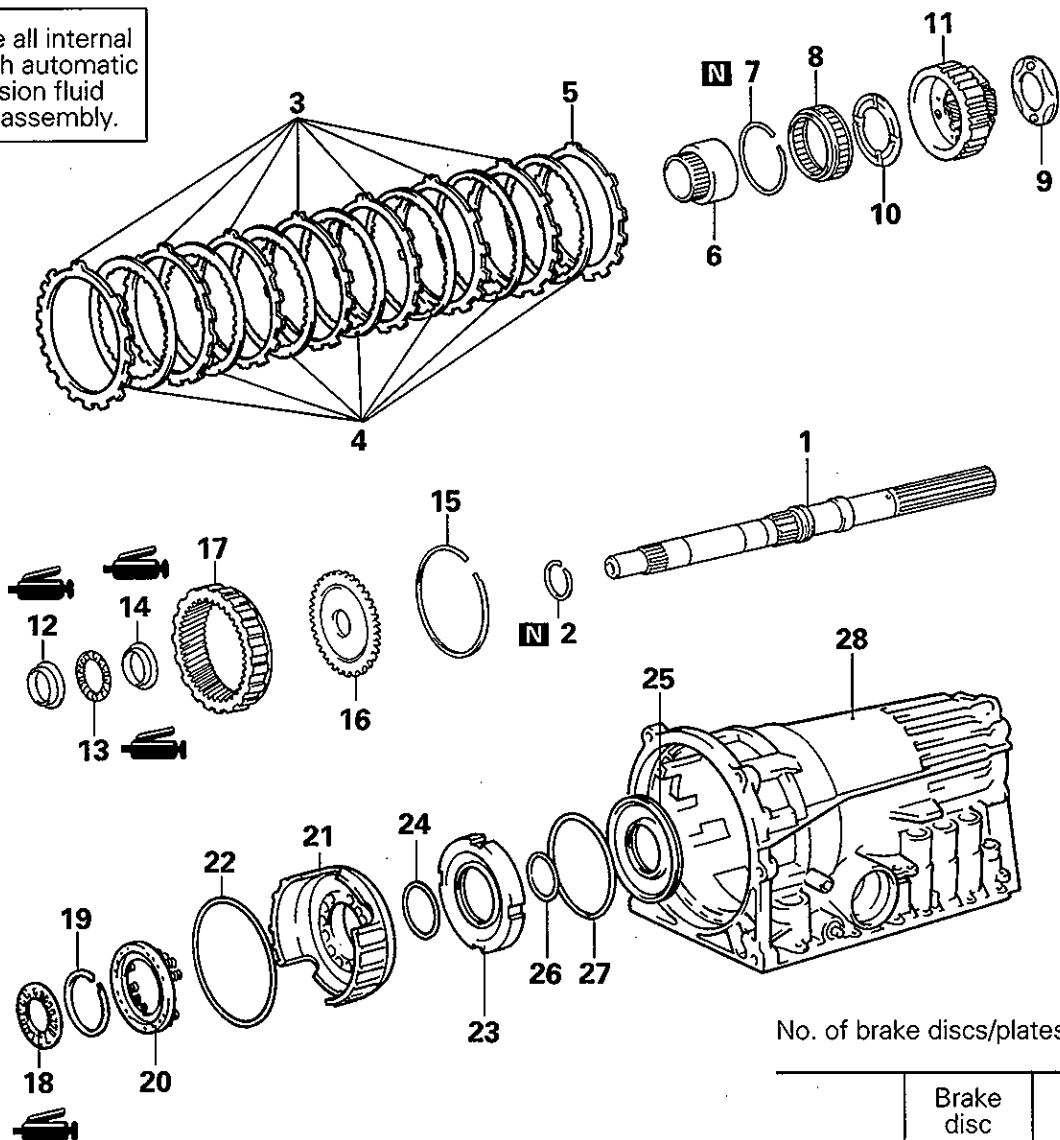

No. of brake discs/plates

	Brake disc	Brake plate
4M40, 6G72	6	6
6G74	7	7

Disassembly steps

- 1. Output shaft
- ▶I 2. Seal ring
- 3. Brake plate
- 4. Brake disc
- 5. Brake flange
- ▶H 6. One-way clutch inner race
- 7. Snap ring
- ▶G 8. One-way clutch No.2
- ▶F 9. Planetary carrier thrust washer No.1
- ▶F 10. Planetary carrier thrust washer No.2
- 11. Rear planetary gear assembly
- ▶E 12. Thrust race
- ▶E 13. Thrust bearing
- ▶E 14. Thrust race
- 15. Snap ring
- 16. Rear planetary ring gear flange
- 17. Rear planetary ring gear
- ▶D 18. Thrust bearing with race
- ◊A 19. Snap ring
- ▶C 20. Return spring assembly
- ◊B 21. First & Reverse brake piston No.2
- 22. O-ring
- ◊C 23. Brake reaction sleeve
- 24. O-ring
- ◊D 25. First & Reverse brake piston No.1
- 26. O-ring
- 27. O-ring
- 28. Transmission case assembly

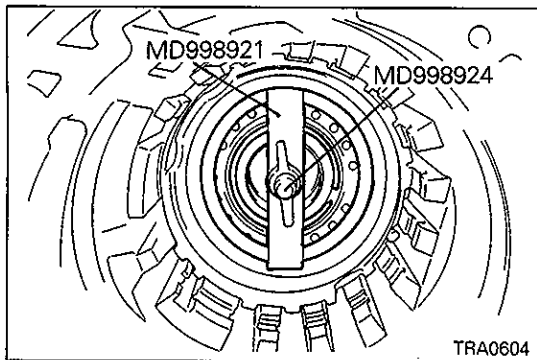

DISASSEMBLY SERVICE POINTS

◊A◊ SNAP RING INSTALLATION

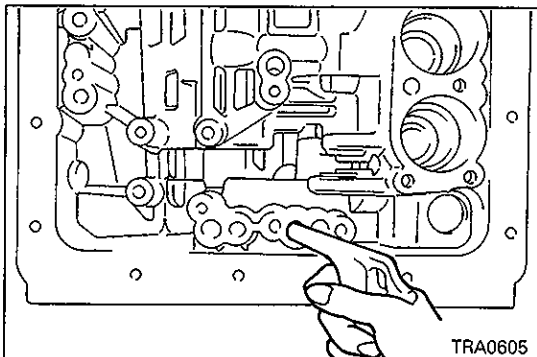

◊B◊ FIRST & REVERSE BRAKE PISTON NO.2 REMOVAL

- (1) With the first & reverse brake piston No.2 held, blow air into the transmission case through the oil hole to remove the first & reverse brake piston No.2.

Caution

- Do not blow air suddenly because the piston may be tipped and become hard to remove.

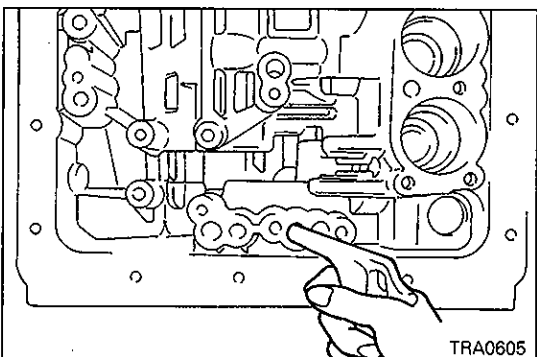

◊C◊ BRAKE REACTION SLEEVE REMOVAL

- (1) With the brake reaction sleeve held, blow air into the transmission case through the oil hole to remove the brake reaction sleeve.

Caution

- Do not blow air suddenly because the sleeve may be tipped and become hard to remove.

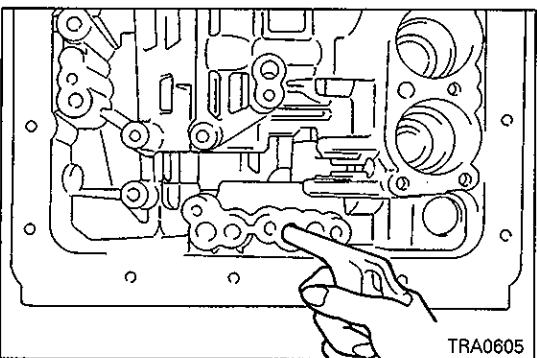

◊D◊ FIRST & REVERSE BRAKE PISTON NO.1 REMOVAL

- (1) With the first & reverse brake piston No.1 held, blow air into the transmission case through the oil hole to remove the piston.

Caution

- Do not blow air suddenly because the piston may be tipped and become hard to remove.

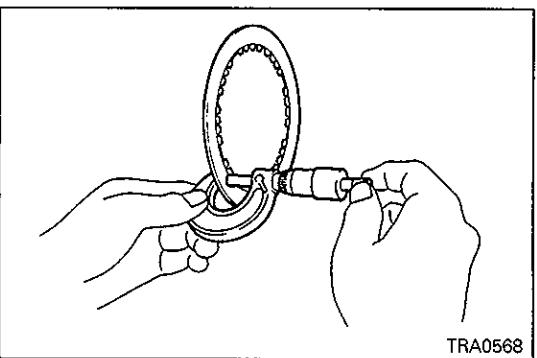

INSPECTION

FIRST & REVERSE BRAKE DISC

- (1) Using a micrometer, measure the thickness of the brake disc.

Limit: 1.51 mm (0.059 in.)

NOTE

The thickness must be measured at two or three points. Compare the average value with the limit.

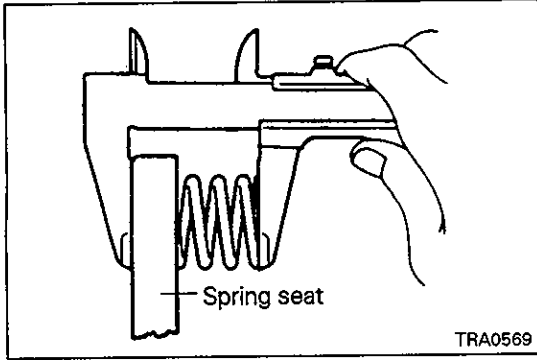

RETURN SPRING ASSEMBLY

- (1) Measure the free length of the spring including the spring seat.

Standard value: Approx. 13.09 mm (0.515 in.)

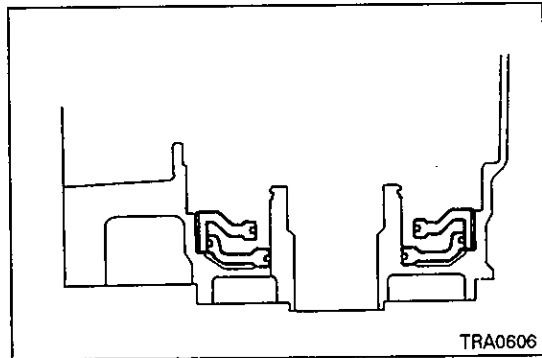

REASSEMBLY SERVICE POINTS

◆A◆ FIRST & REVERSE BRAKE PISTON NO.1 / REVERSE BRAKE SLEEVE INSTALLATION

- (1) Install the first & reverse brake piston No.1 and the reverse brake sleeve together to the transmission case.

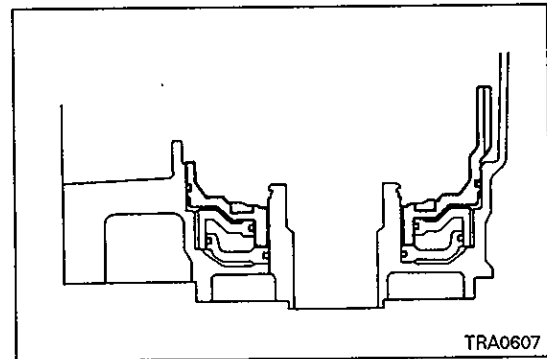

◆B◆ FIRST & REVERSE BRAKE PISTON NO.2 INSTALLATION

- (1) Aligning the convex of the first & reverse brake piston No.2 with the concave of the transmission case, install the piston to the case.

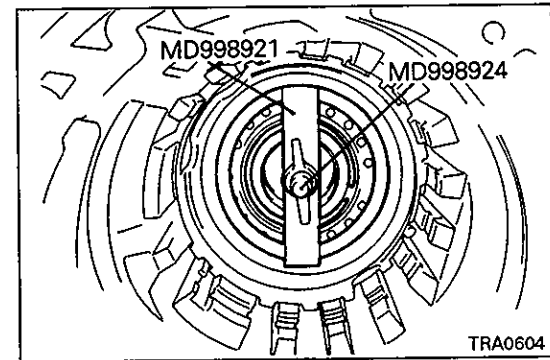

◆C◆ SNAP RING INSTALLATION

Caution

- Be sure the end gap of the snap ring is not aligned with the stopper of the spring seat.

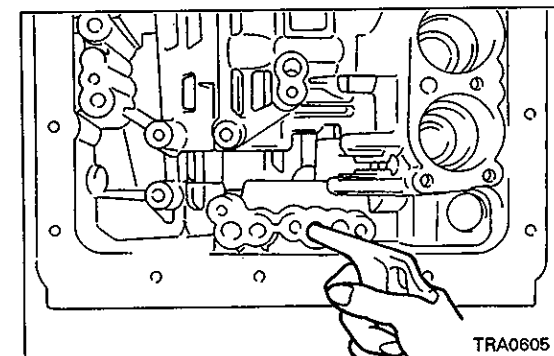

- (1) After the snap ring is installed, check the operation of the first & reverse brake piston as follows:
- (2) By applying compressed air (400 – 800 kPa, 4 – 8 kg/cm², 57 – 113 psi) into the oil hole of the transmission case as illustrated, check that the first & reverse brake piston slides smoothly.

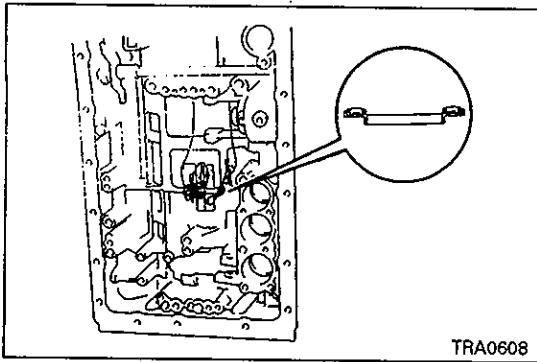

◆D◆ THRUST BEARING WITH RACE INSTALLATION

- (1) Apply petrolatum to the thrust bearing with race and attach it so that the race side is oriented to the transmission case side.

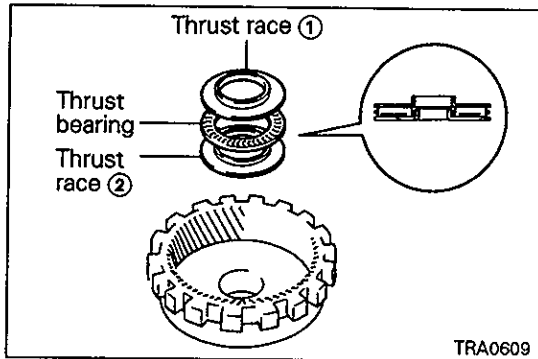

◆E◆ THRUST RACE / THRUST BEARING / THRUST RACE INSTALLATION

- (1) Apply petrolatum to the thrust bearing, thrust race [28.8 mm (1.13 in.) in inner diameter] and thrust race [27.6 mm (1.09 in.) in inner diameter] and attach them to the rear planetary ring gear in the illustrated order and direction.

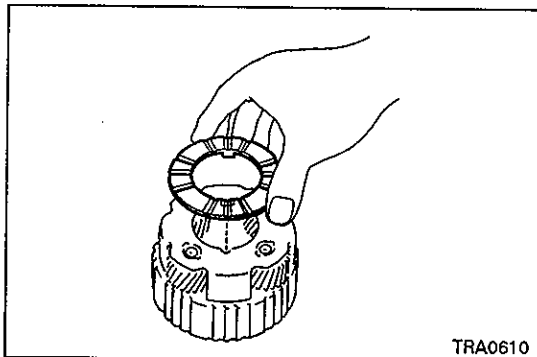

◆F◆ PLANETARY CARRIER THRUST WASHERS NO.1 AND NO.2 INSTALLATION

- (1) Aligning the convex of the thrust washer No.1 with the hole of the rear planetary gear, install the washer to the gear.

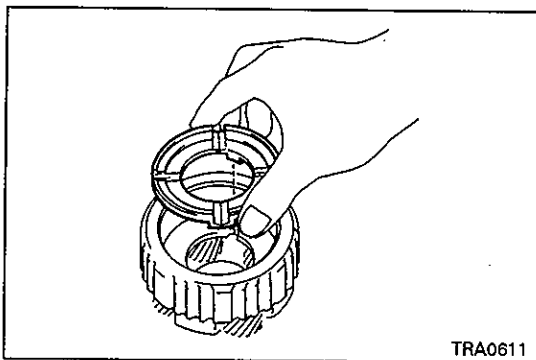

- (2) Turn the rear planetary gear over. Aligning the convex of the thrust washer No.2 with the hole of the rear planetary gear, install the washer to the gear.

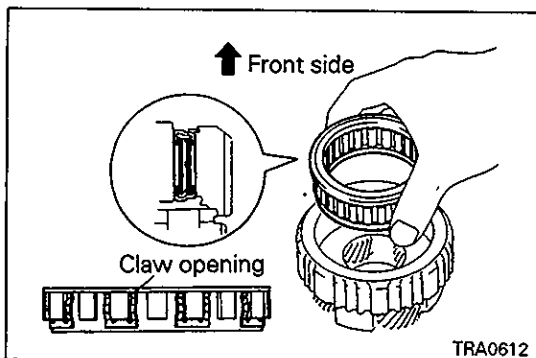

◆G◆ ONE-WAY CLUTCH NO.2 INSTALLATION

- (1) Install the one-way clutch No.2 to the rear planetary gear in the illustrated direction.

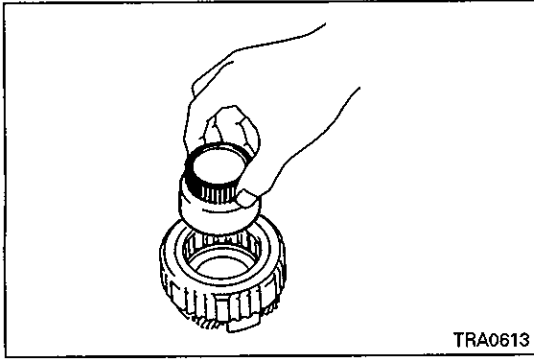

◆H◆ ONE-WAY CLUTCH INNER RACE INSTALLATION

(1) After the one-way clutch inner race is installed, check the operation of the one-way clutch No.2 as follows:

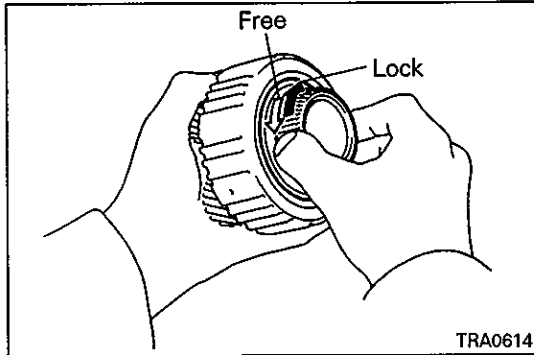

(2) While holding the rear planetary gear, turn the one-way clutch clockwise to see that the clutch is locked and turn it counterclockwise to see that the clutch turns.

NOTE

- (1) If the one-way clutch turns or locks in both directions, replace the one-way clutch.
- (2) If the one-way clutch turns clockwise while it doesn't counterclockwise, the one-way clutch may have been assembled in the reverse direction.

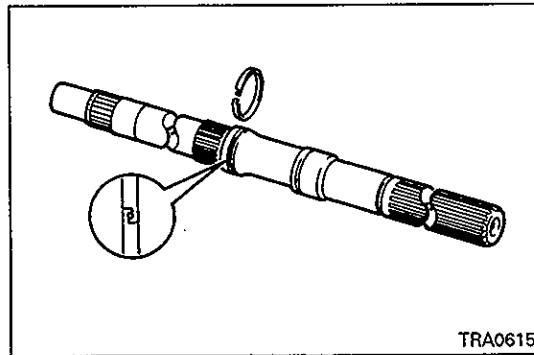

◆H◆ SEAL RING INSTALLATION

(1) Apply ATF to the seal ring and attach it to the output shaft.

Caution

- Do not bend the claw of the seal ring.
- Do not open the seal ring wider than necessary.

NOTES

14. SECOND COAST BRAKE PISTON DISASSEMBLY AND REASSEMBLY

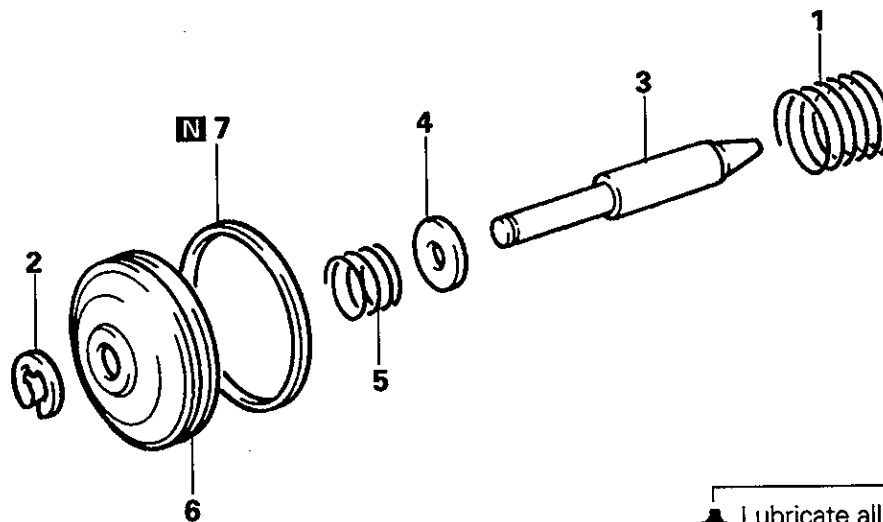

 Lubricate all internal parts with automatic transmission fluid during reassembly.

Disassembly steps

1. Spring
2. E-ring
3. Second coast brake piston rod
4. Plate washer
5. Spring
6. Second coast brake piston
7. Seal ring

TRA0616

NOTES

15. VALVE BODY

DISASSEMBLY AND REASSEMBLY

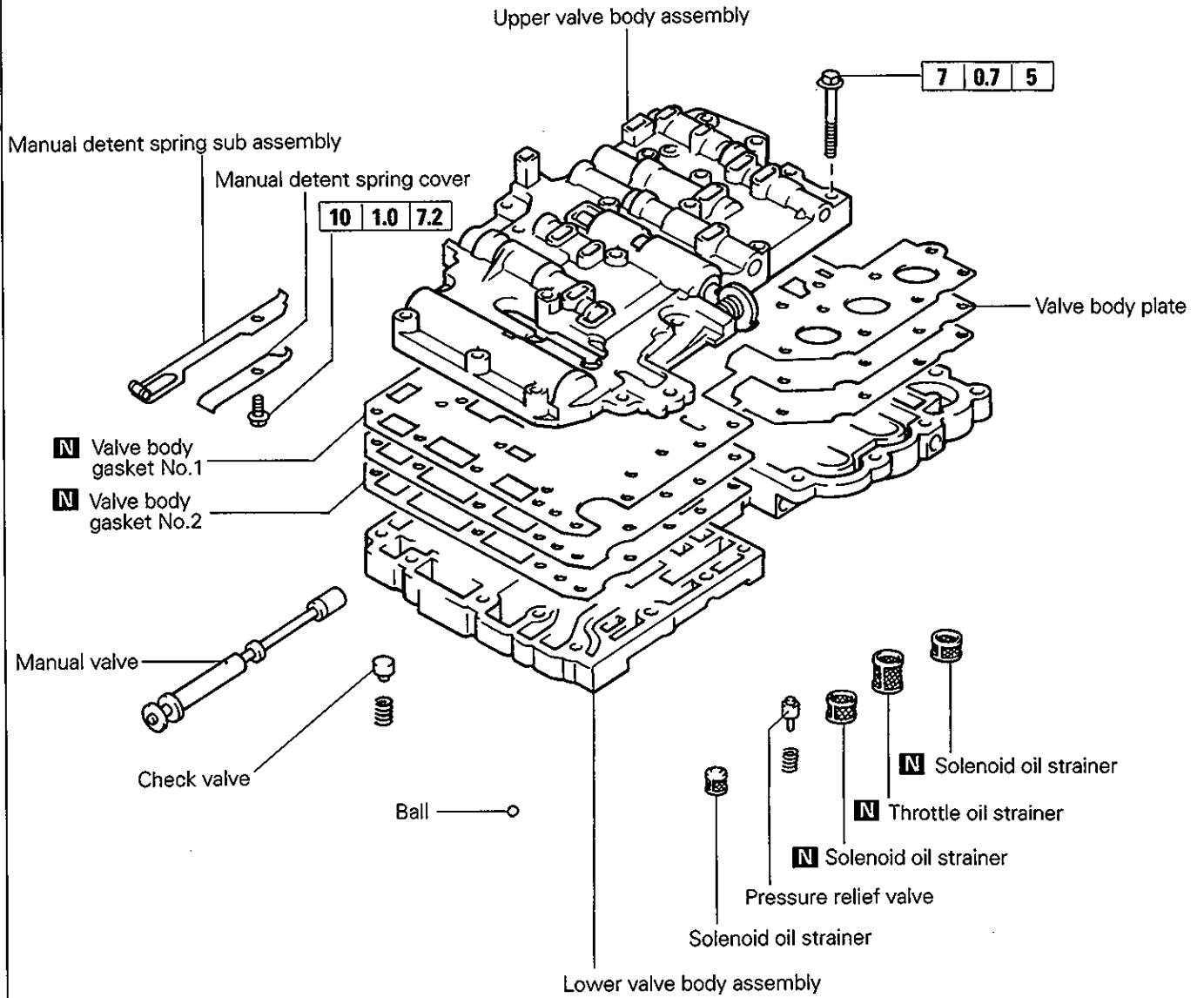

 Lubricate all internal parts with automatic transmission fluid during reassembly.

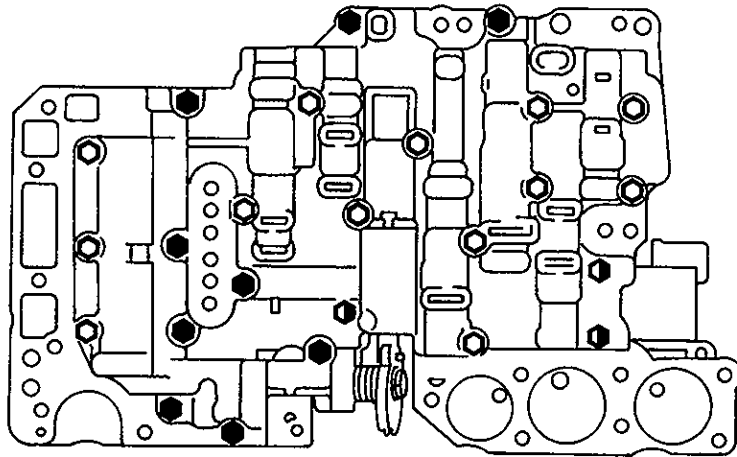

Bolt shank length

⬡ : 38 mm (1.50 in.)

● : 20 mm (0.79 in.)

⬢ : 28 mm (1.10 in.)

TRA0618

DISASSEMBLY

- (1) Remove the bolt and then remove the detent spring and cover.

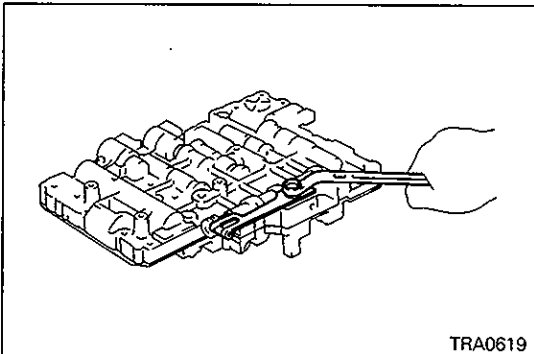

TRA0619

- (2) Remove the manual valve from the lower valve body.

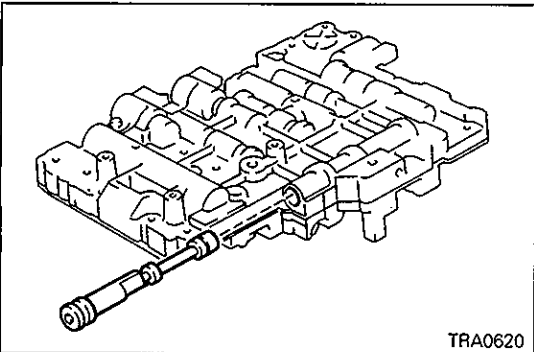

TRA0620

- (3) Using a deep socket wrench [8 mm (0.31 in.)], remove the 25 bolts from the upper valve body.

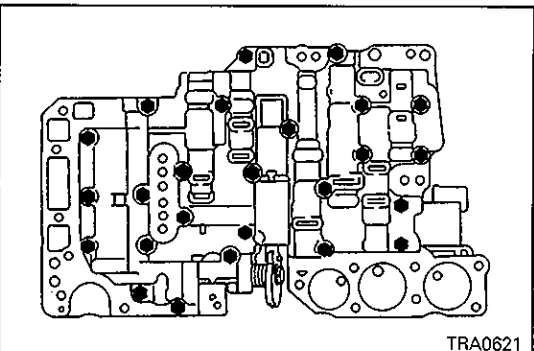

TRA0621

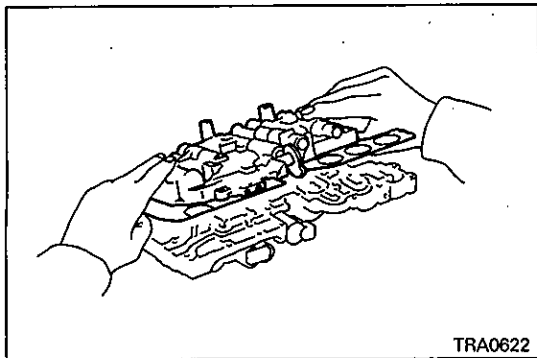

- (4) Separate the upper valve body from the lower valve body by pushing the valve body plate and gasket toward the upper valve body.
- (5) Place the upper valve body on the workbench with the side having the gasket and plate upward.

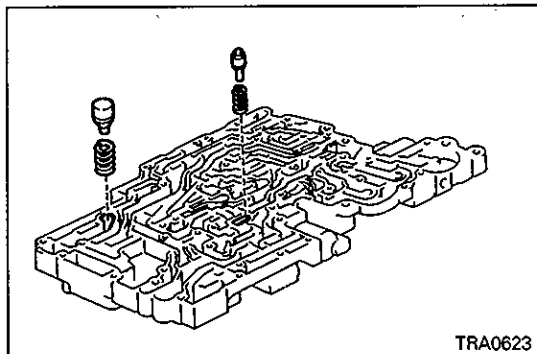

- (6) Remove the check valve and spring from the lower valve body.
- (7) Remove the pressure relief valve and spring from the lower valve body.

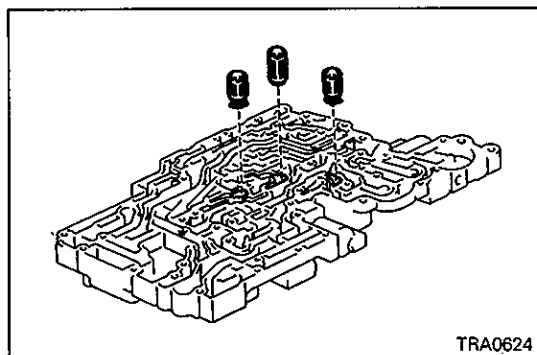

- (8) Remove the three strainers from the lower valve body.

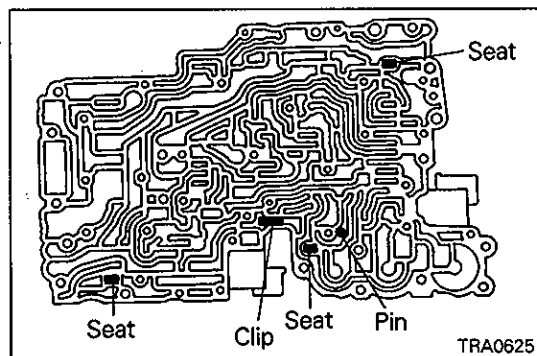

- (9) Check that the three seats, one pin and one clip are in position on the lower valve body.

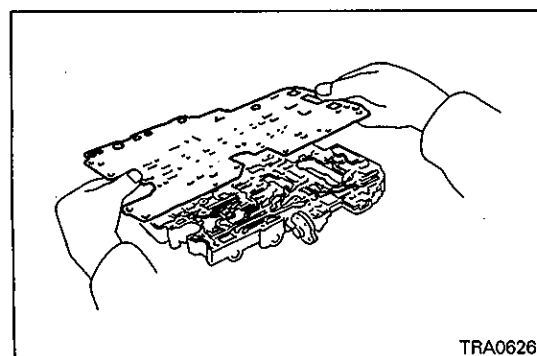

- (10) Remove the two valve body gaskets and the plate from the upper valve body.

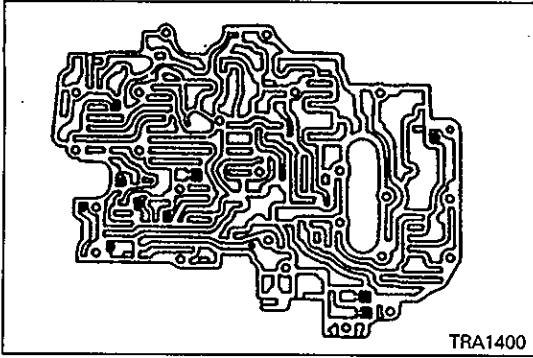

(11) Remove the 9 balls or 10 balls from the upper valve body.

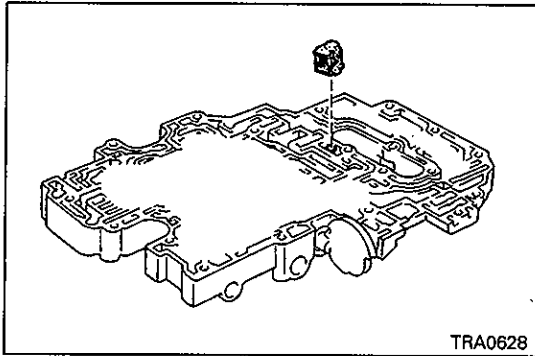

(12) Remove the strainer from the upper valve body.

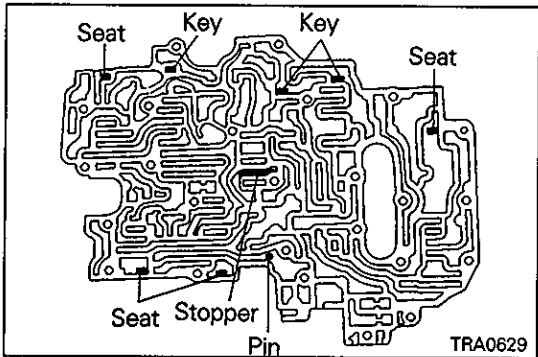

(13) Check that the one pin, four seats, three keys and one vibrating stopper are all in position.

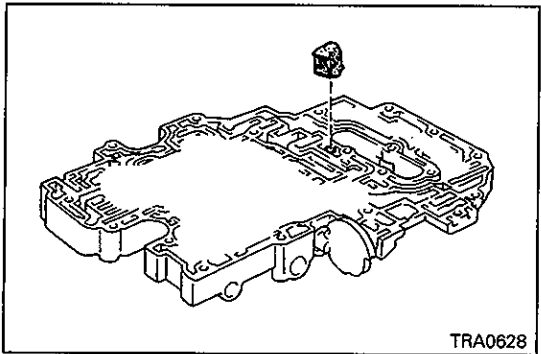

REASSEMBLY

(1) Install the solenoid oil strainer to the upper valve body.

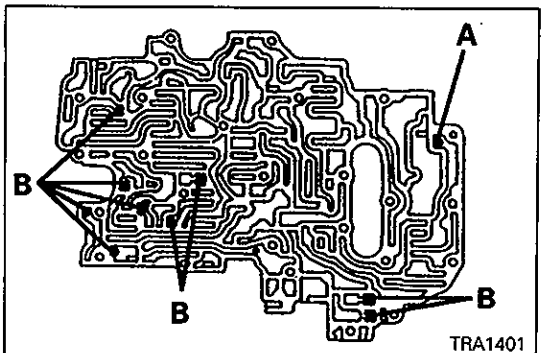

(2) Install two types of 9 balls or 10 balls to the upper valve body.
mm (in.)

Place	Dimension	Outer diameter
Rubber ball A		6.35 (0.250)
Rubber ball B		5.56 (0.219)

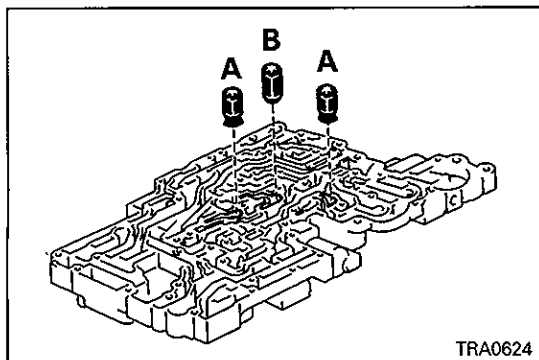

TRA0624

(3) Install the two solenoid oil strainers and one throttle oil strainer to the lower valve body.

mm (in.)

Type	Dimension	Outer diameter	Height
Solenoid oil strainer A		10.2 – 10.4 (0.401 – 0.409)	12.2 – 12.6 (0.480 – 0.488)
Throttle oil strainer B		10.2 – 10.4 (0.401 – 0.409)	19.3 – 19.7 (0.760 – 0.776)

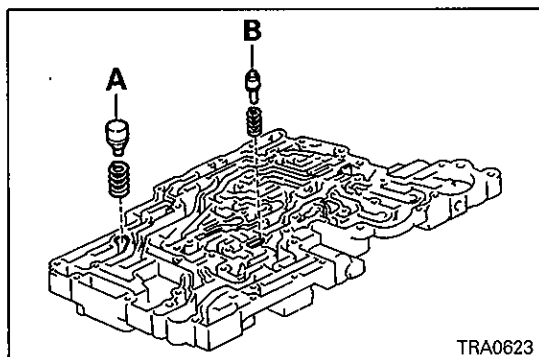

TRA0623

(4) Install the two springs and then the check valve and pressure relief valve to the lower valve body.

Spring

mm (in.)

Place	Dimension	Free height	Outside diameter	Number of loops	Wire diameter
Check valve		17.53 (0.690)	12.1 (0.476)	3.2	1.1 (0.043)
Relief valve		11.2 (0.441)	6.4 (0.252)	7.5	0.9 (0.035)

Valve

mm (in.)

Type	Dimension	Outer diameter	Height
Check valve A		12.8 (0.504)	17.5 (0.689)
Pressure relief valve B		6.7 (0.264)	16.5 (0.650)

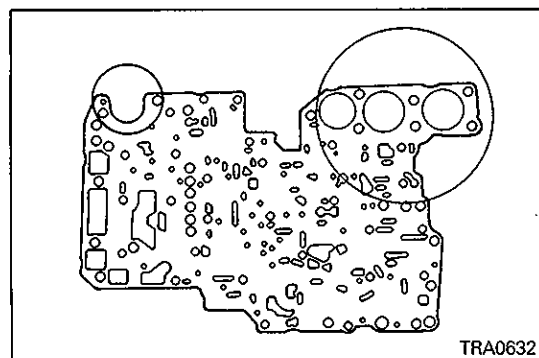

TRA0632

(5) In alignment with the bolt holes, install a new valve body gasket No.1 on the upper valve body.

(6) In alignment with the bolt holes, put the plate on the gasket No.1.

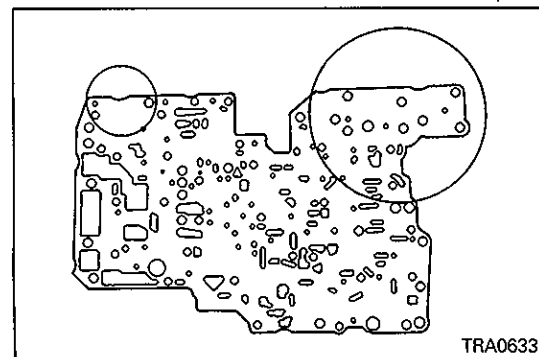

TRA0633

(7) Put a new valve body gasket No.2 on the plate.

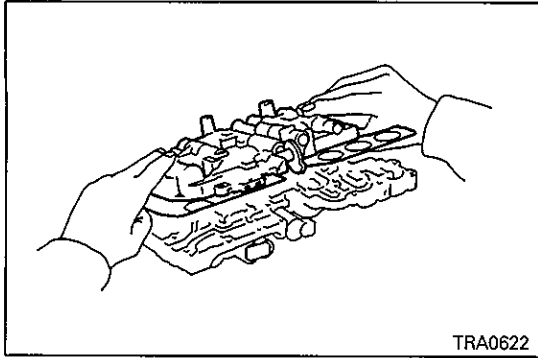

- (8) While pushing the gaskets and the plate against the upper valve body, put the upper valve body on the lower valve body.

Caution

- Be careful not to drop the checkballs and strainers from the upper valve body.

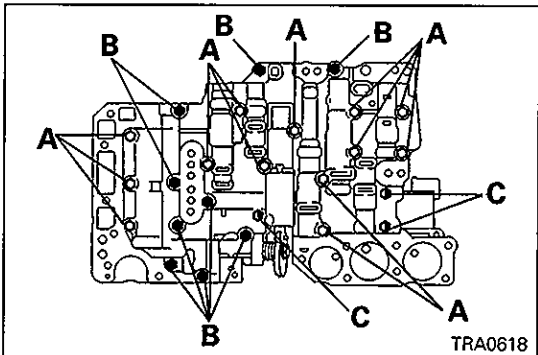

- (9) Insert the 25 bolts from the upper valve body side.

A: 38 mm (1.50 in.)

B: 20 mm (0.79 in.)

C: 28 mm (1.10 in.)

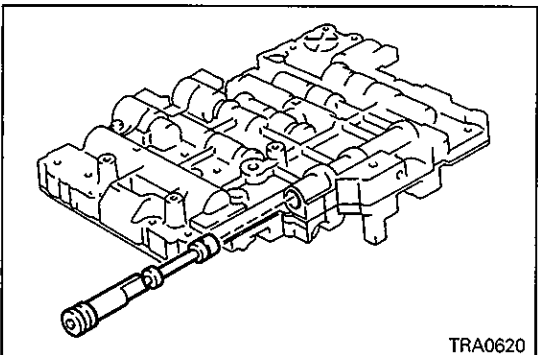

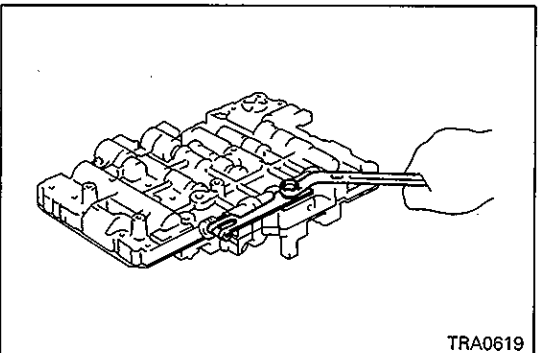

- (10) Install the manual valve to the lower valve body.

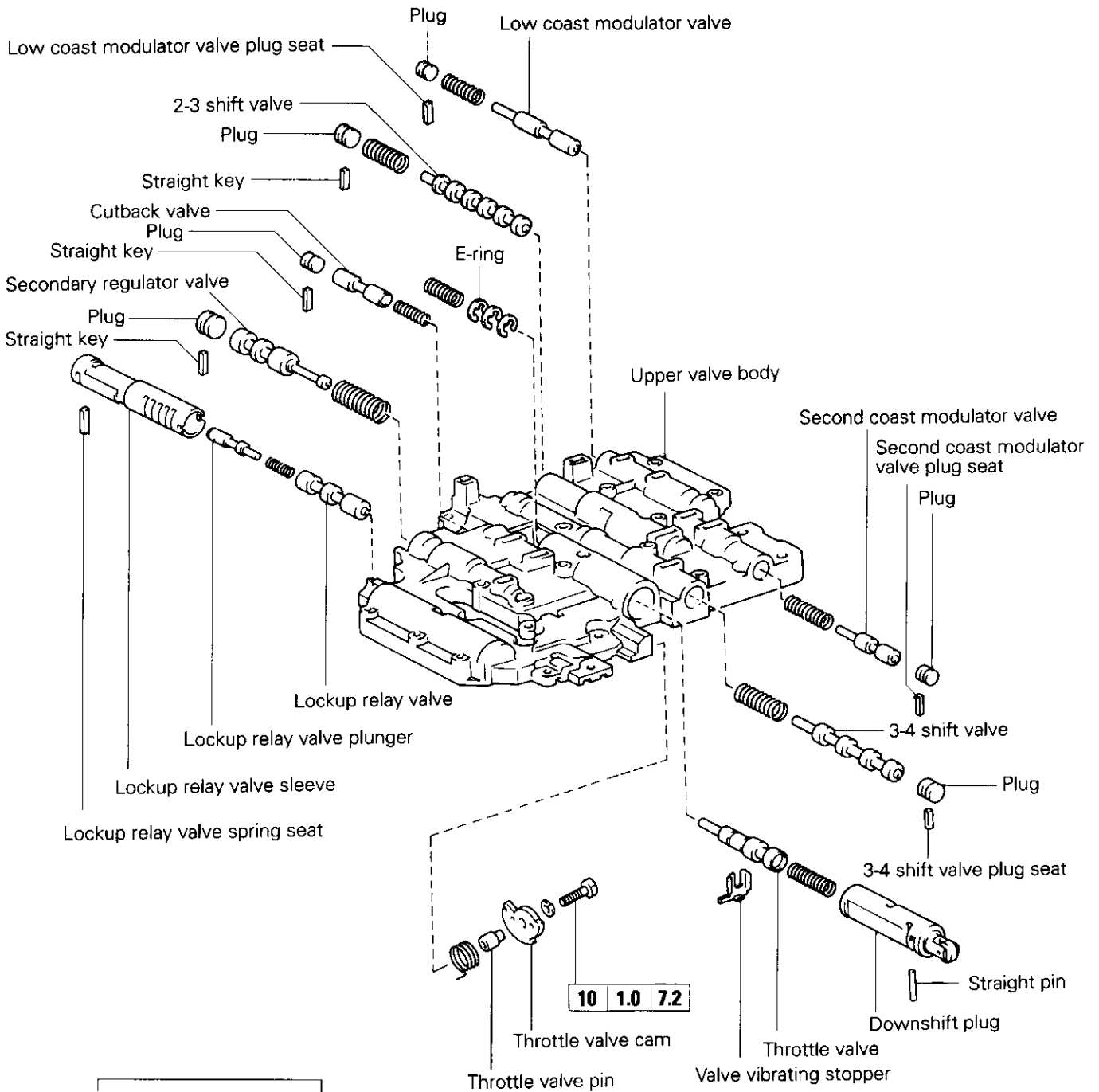

- (11) Install the detent spring and cover by tightening the bolt.

16. UPPER VALVE BODY DISASSEMBLY AND REASSEMBLY



 Lubricate all internal parts with automatic transmission fluid during reassembly.

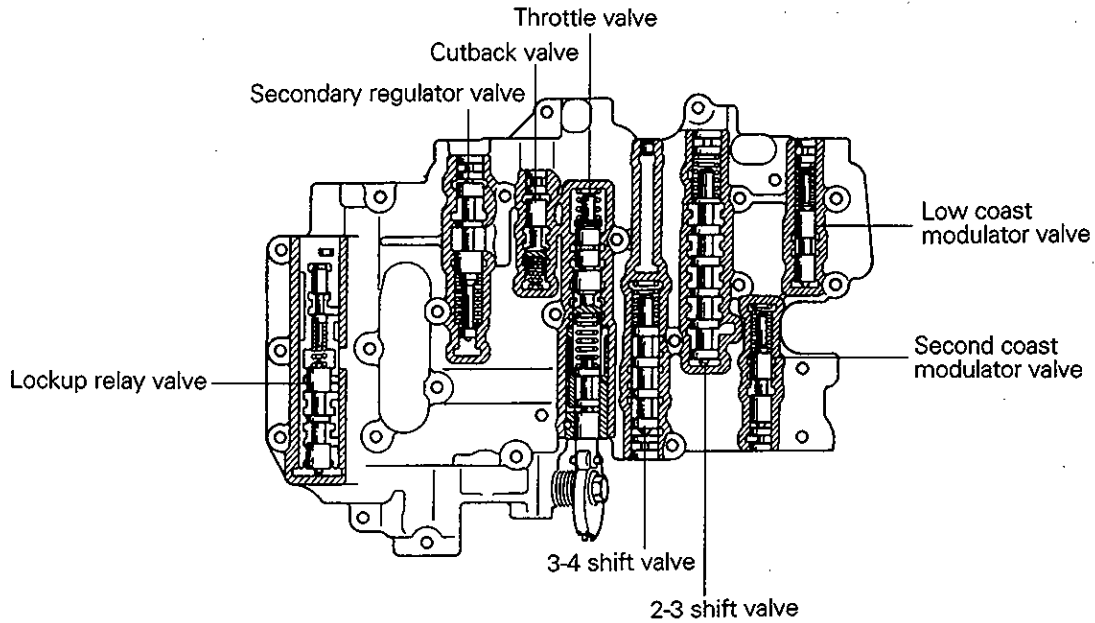

TRA0635

DISASSEMBLY

- (1) Remove the valve vibrating stopper.

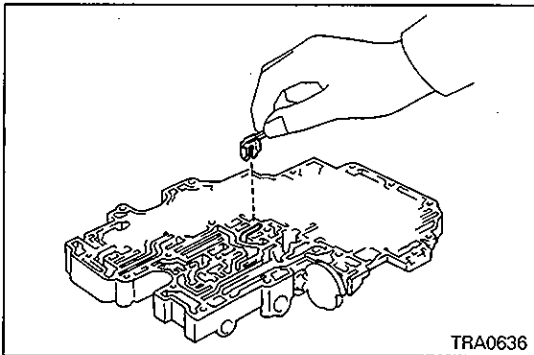

TRA0636

- (2) Remove the bolt and washer and then the throttle valve cam, pin and spring.

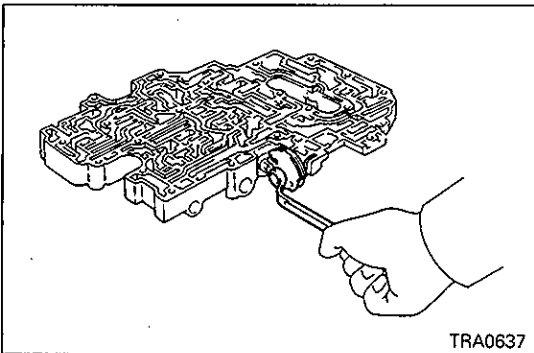

TRA0637

- (3) While pushing the downshift plug with a finger, use a magnet to remove the pin.

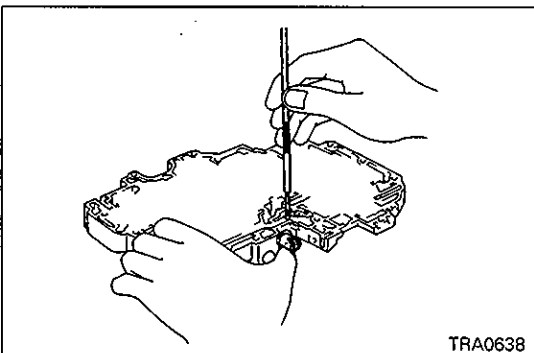

TRA0638

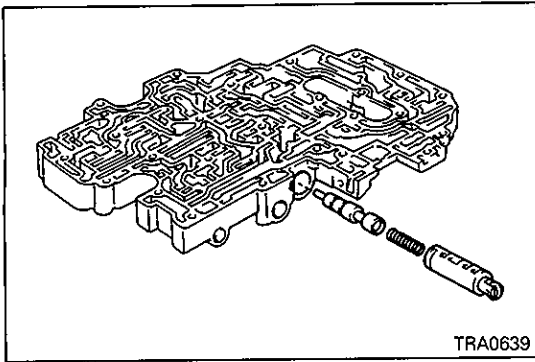

(4) Remove the downshift plug, spring and throttle valve.

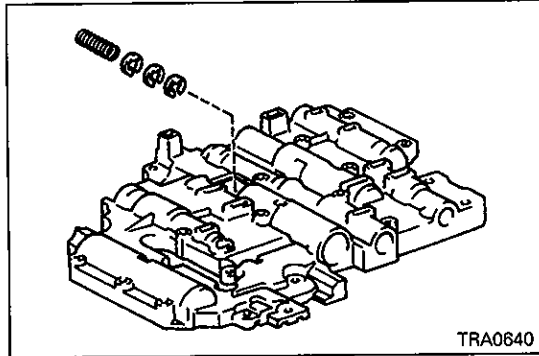

(5) Remove the spring and E-rings from the rear of the valve body.

Caution

- Because the throttle pressure changes depending on the number of E-rings, remember how many E-rings have been used (sometimes zero).

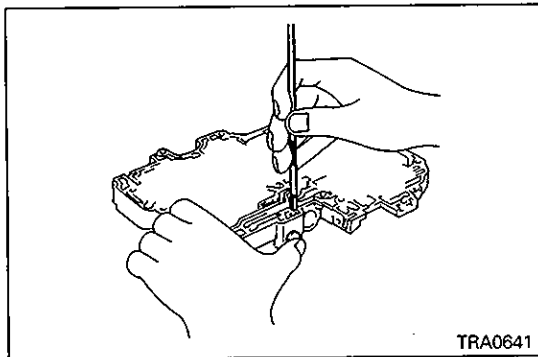

(6) While pushing the plug with a finger, use a magnet to remove the seat.

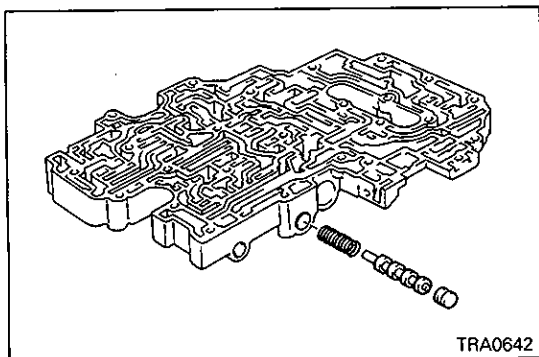

(7) Remove the plug, 3-4 sift valve and spring.

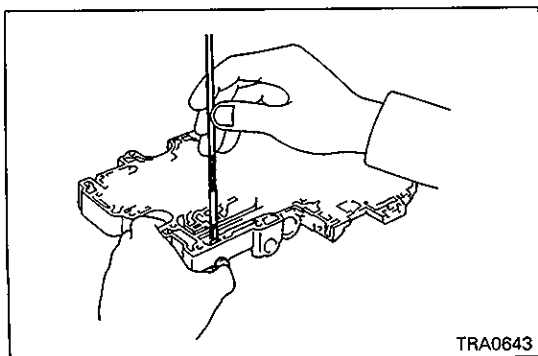

(8) While pushing the plug with a finger, use a magnet to remove the seat.

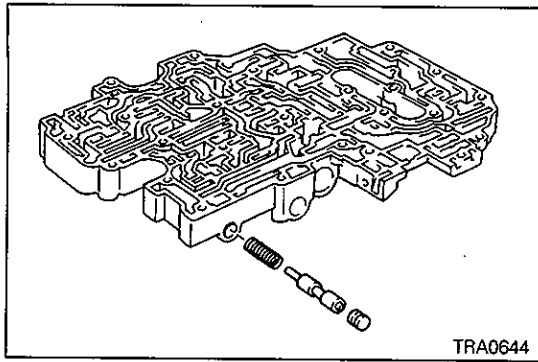

(9) Remove the plug, second coast modulator valve and spring.

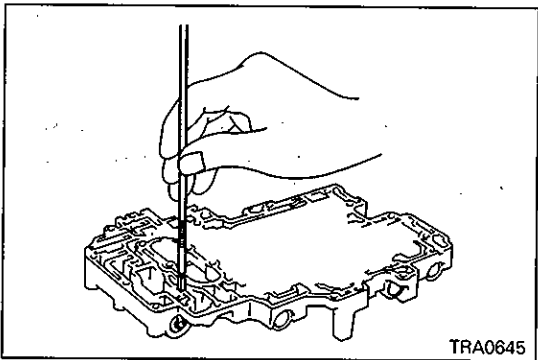

(10) Using a magnet, remove the seat.

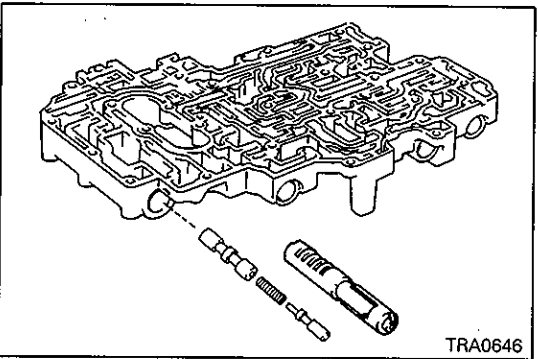

(11) Remove the lockup relay valve sleeve, lockup relay plunger, spring and lockup relay valve together.

(12) Remove the lockup relay valve, spring and lockup relay valve plunger from the lockup relay valve sleeve.

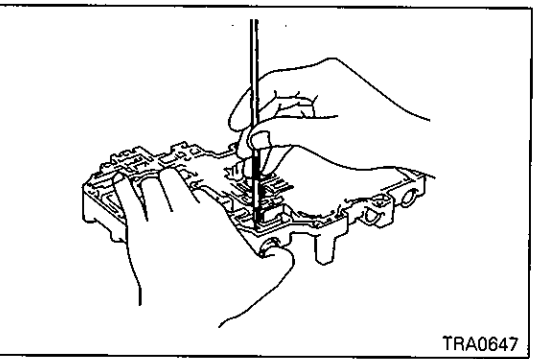

(13) While pushing the plug with a finger, use a magnet to remove the key.

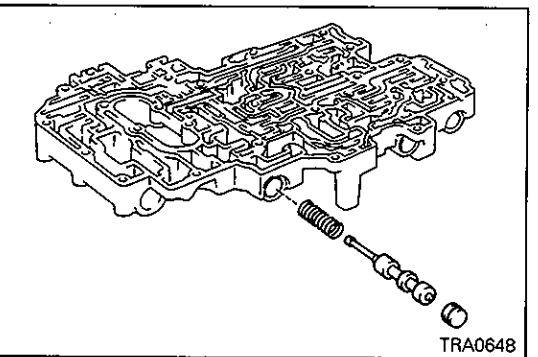

(14) Remove the plug, second regulator valve and spring.

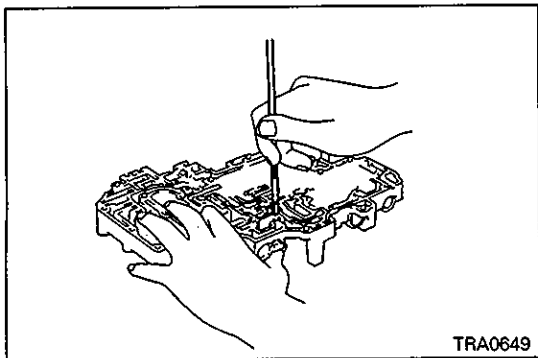

(15) While pushing the plug with a finger, use a magnet to remove the key.

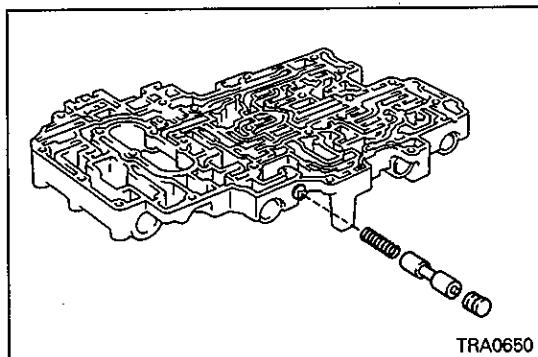

(16) Remove the plug, cutback valve and spring.

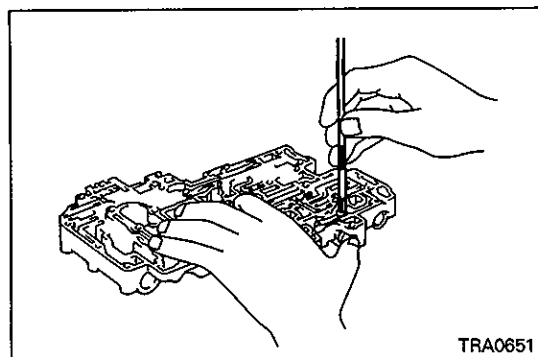

(17) While pushing the plug with a finger, use a magnet to remove the key.

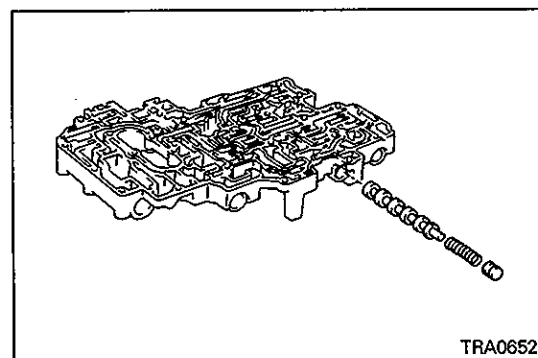

(18) Remove the plug, spring and 2-3 shift valve.

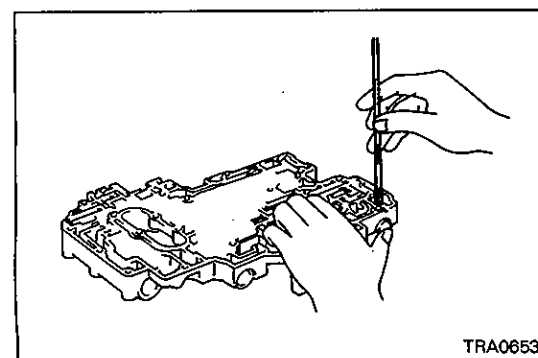

(19) While pushing the plug with a finger, use a magnet to remove the seat.

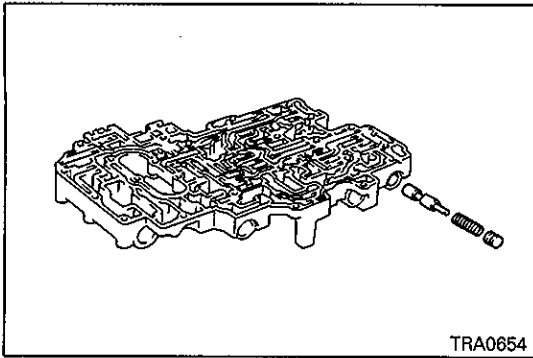

(20) Remove the plug, spring and low coast modulator valve.

INSPECTION VALVE SPRING

(1) Check the free height and outside diameter of each spring.

Standard value

Place	Dimension	Free height	Outside diameter	Number of loops	Wire diameter
(1) Downshift plug		27.3 (1.075)	8.7 (0.343)	10.5	1.0 (0.039)
(2) Throttle valve		20.6 (0.811)	9.2 (0.362)	7.5	0.7 (0.028)
(3) 3-4 shift valve		30.8 (1.213)	9.7 (0.381)	8.5	0.9 (0.035)
(4) Second coast modulator valve*1		30.9 (1.217)	8.6 (0.339)	9.5	1.1 (0.043)
	Second coast modulator valve*2	29.6 (1.165)	8.3 (0.327)	10.5	1.0 (0.039)
(5) Lockup relay valve		21.4 (0.843)	5.5 (0.217)	15.5	0.6 (0.024)
(6) Secondary regulator valve		30.9 (1.217)	11.2 (0.441)	8.5	1.5 (0.059)
(7) Cutback valve		21.8 (0.858)	6.0 (0.236)	11.5	0.6 (0.024)
(8) 2-3 shift valve		30.8 (1.213)	9.7 (0.381)	8.5	0.9 (0.035)
(9) Low coast modulator valve		30.4 (1.197)	8.3 (0.327)	8.5	0.8 (0.031)

Unit of free height, outside diameter and wire diameter: mm (in.)

NOTE

*1: Except V4AW3-B-U

*2: V4AW3-B-U only

REASSEMBLY

- (1) Install the low coast modulator valve, spring and plug as illustrated.
- (2) While pushing the plug with a finger, install the seat.

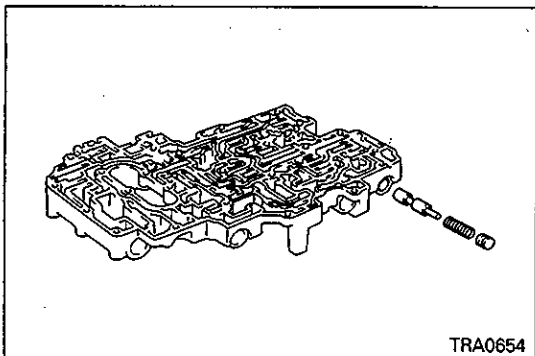
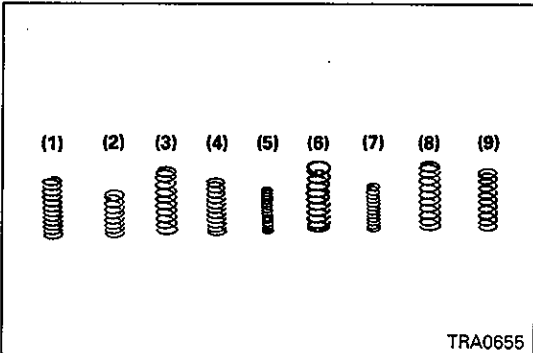

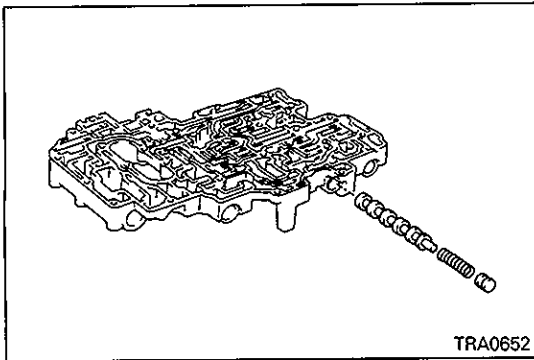

- (3) Install the 2-3 shift valve, spring and plug as illustrated.
- (4) While pushing the plug with a finger, install the key.

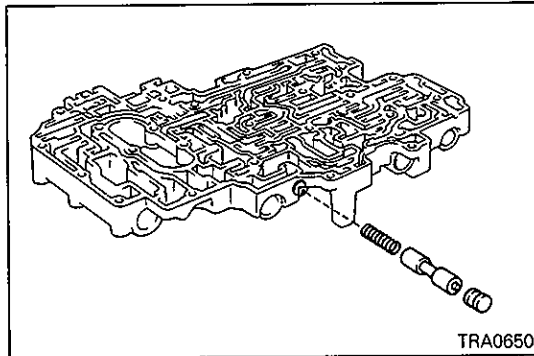

- (5) Install the spring, cutback valve and plug as illustrated.
- (6) While pushing the plug with a finger, install the key.

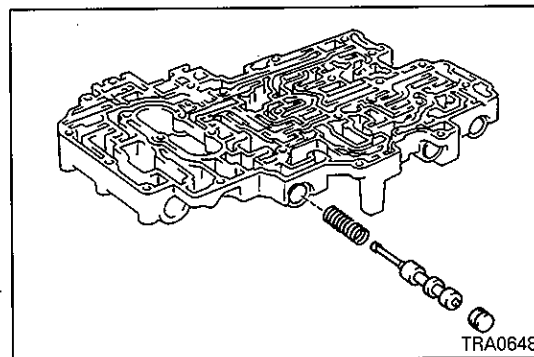

- (7) Install the spring, secondary regulator valve and plug as illustrated.
- (8) While pushing the plug with a finger, install the key.

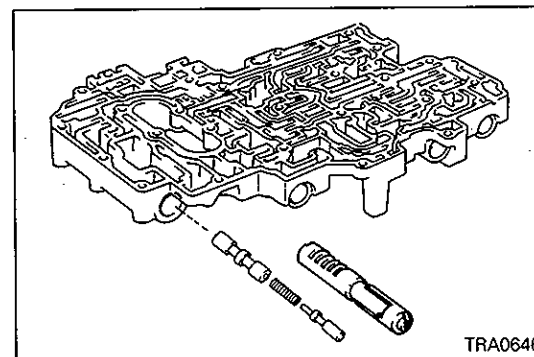

- (9) Install the lockup relay valve plunger and spring to the lockup relay valve sleeve as illustrated.
- (10) Install the lockup relay valve to the lockup relay valve sleeve.
- (11) Install the lockup relay valve sleeve, lockup relay valve, spring, and lockup relay valve plunger together as illustrated.
- (12) Install the seat.

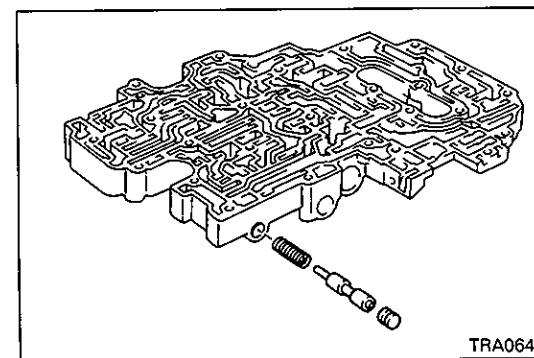

- (13) Install the spring, second coast modulator valve and plug as illustrated.
- (14) While pushing the plug with a finger, install the seat.

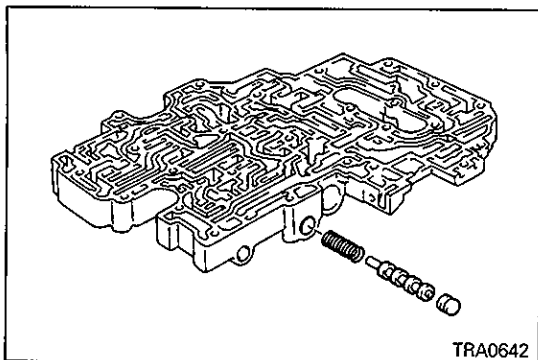

- (15) Install the spring, 3-4 shift valve and plug as illustrated.
 (16) While pushing the plug with a finger, install the seat.

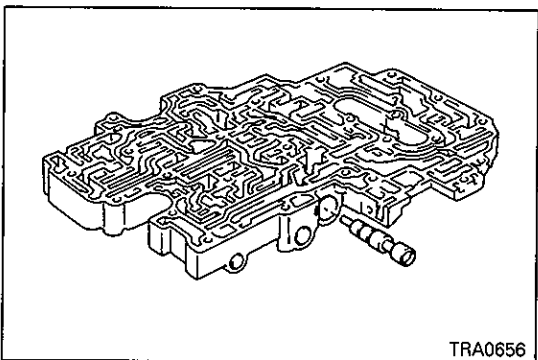

- (17) Install the throttle valve to the valve body as illustrated.

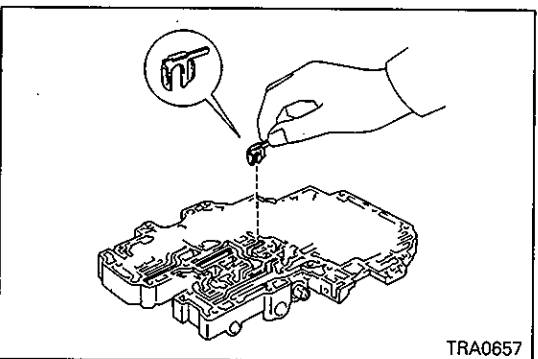

- (18) Install the valve vibrating stopper in the illustrated position.

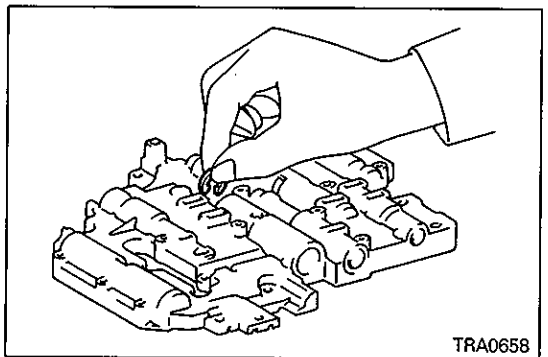

- (19) With the valve vibrating stopper held with a finger, turn the valve body over. Install the E-rings to the throttle valve.

Caution

- The number of E-rings to be installed must be equal to that of the E-rings which were removed.

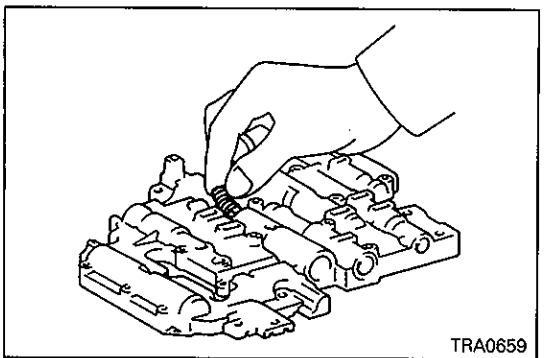

- (20) Install the spring to the throttle valve.

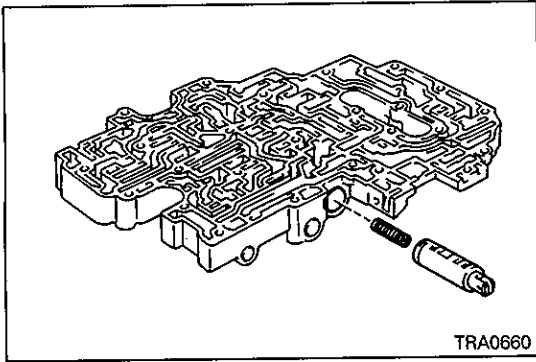

- (21) Turn the valve body over again. Install the spring and downshift valve as illustrated.
- (22) While pushing the downshift valve with a finger, install the pin.

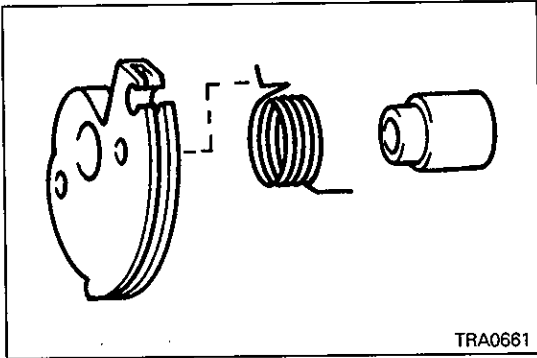

- (23) Install the spring and collar to the throttle valve cam.

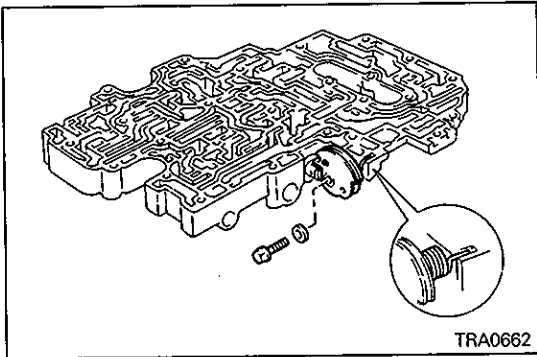

- (24) Install the throttle valve cam to the valve body and check that the spring is anchored to the valve body by the claw.
- (25) Tighten the bolt together with the washer.

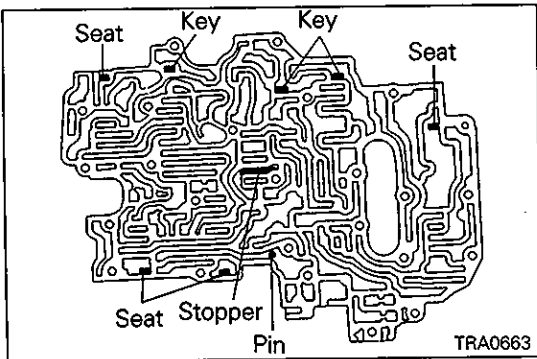



- (26) Check that the one pin, four seats, three keys and one vibrating stopper are installed as illustrated.

NOTES

17. LOWER VALVE BODY

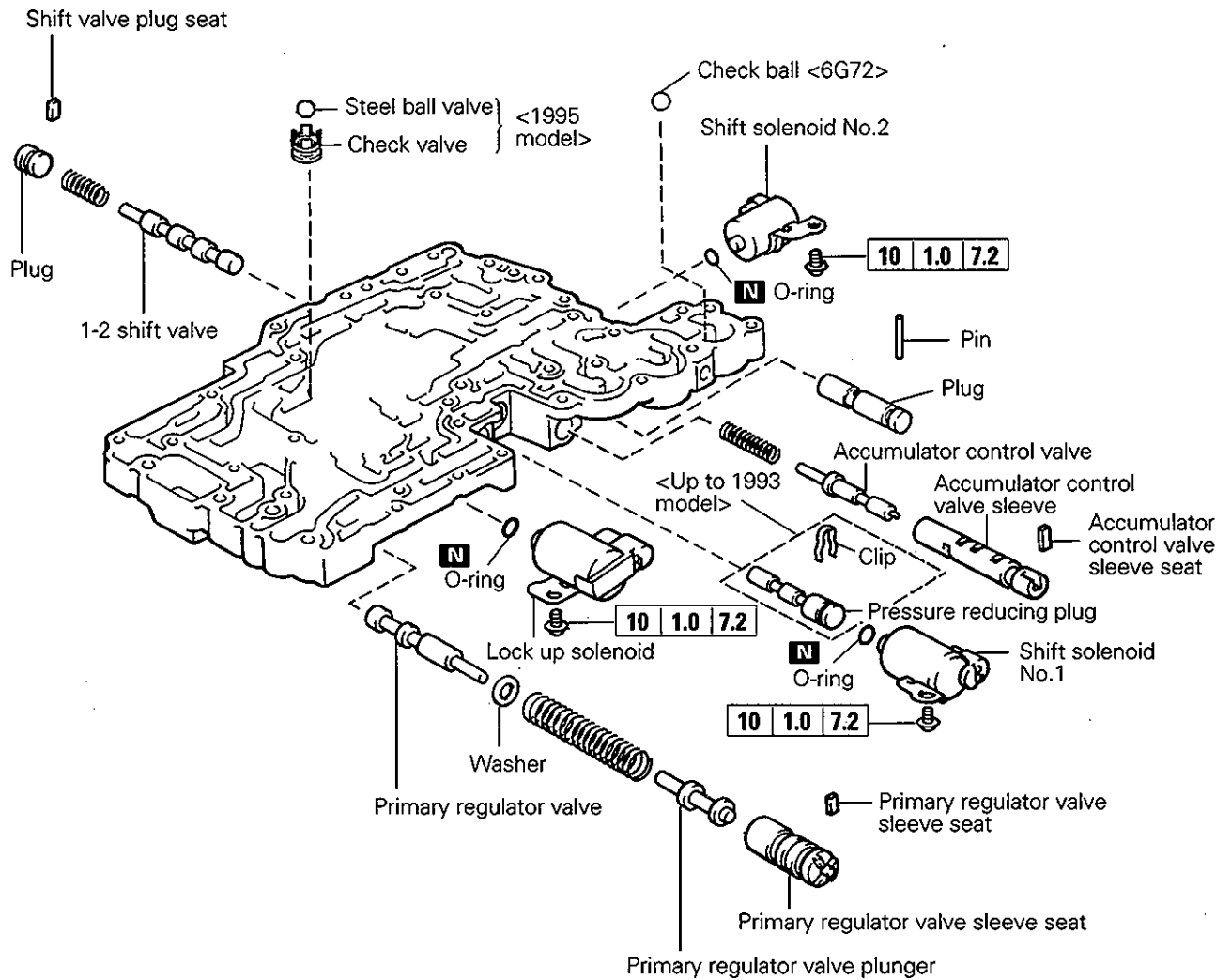
DISASSEMBLY AND REASSEMBLY <Up to 1995 models>



 Lubricate all internal parts with automatic transmission fluid during reassembly.

DISASSEMBLY AND REASSEMBLY <1996 model>

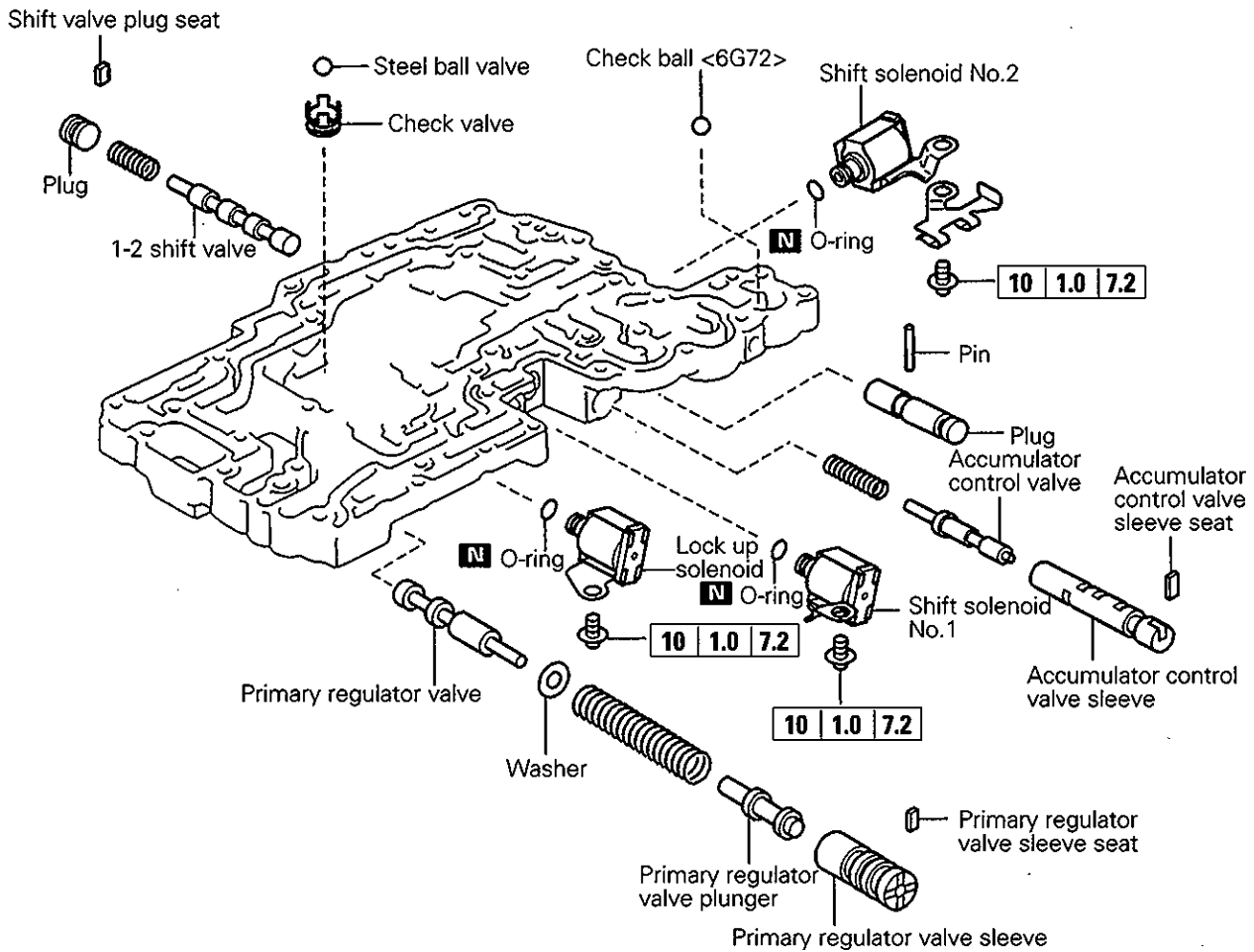

 Lubricate all internal parts with automatic transmission fluid during reassembly.

Intentionally blank

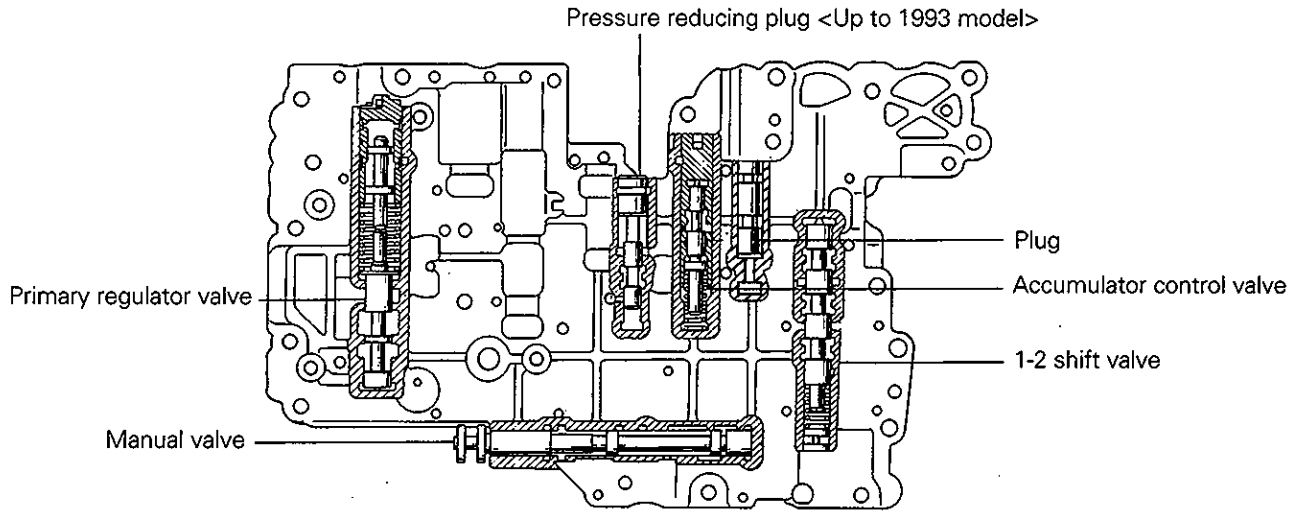

TRA0837

<Up to MODEL 1995>

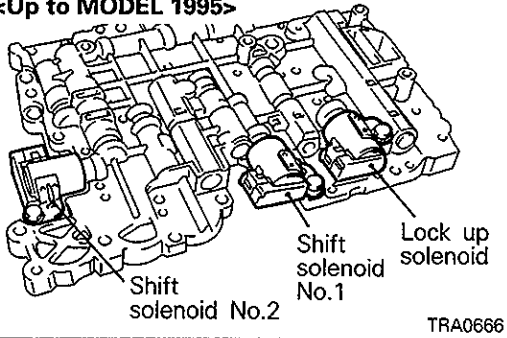

DISASSEMBLY

- (1) Remove the steel ball and check valve.
- (2) Remove the check ball. <6G72>
- (3) Remove each bolt and then remove the shift solenoids No. 1, No. 2 and lock up solenoid.
- (4) Remove the O-ring from each solenoid.

<MODEL 1996>

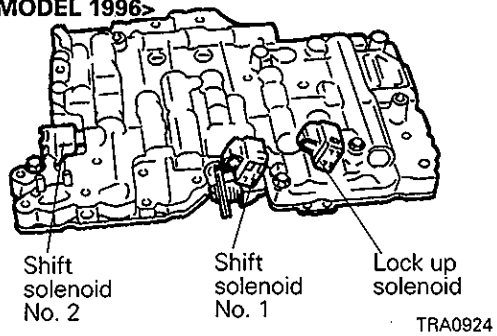

- (5) While pushing the plug with a finger, use a magnet to remove the seat.

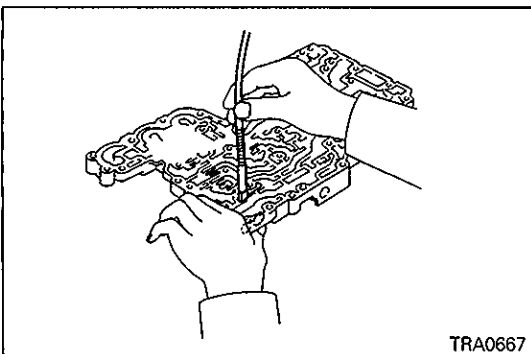

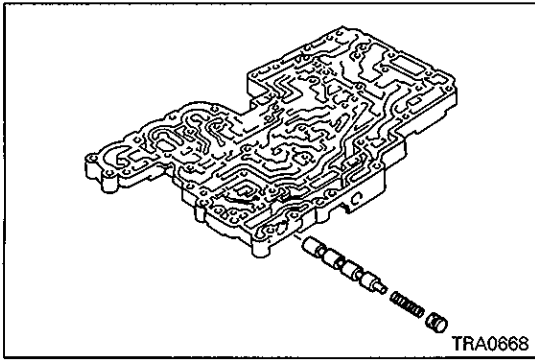

(6) Remove the plug, spring and 1-2 shift valve.

Intentionally blank

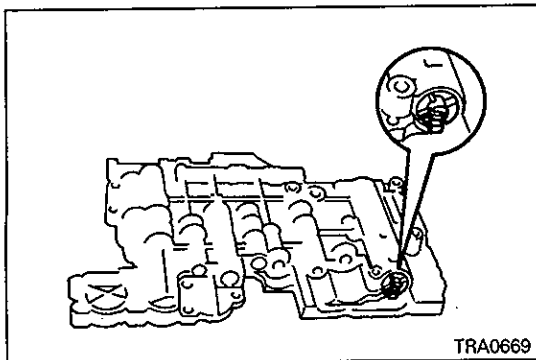

- (7) Examine which groove of the primary regulator valve sleeve engages with the seat.

Caution

- Because this has influence on the line pressure, make a note of it.

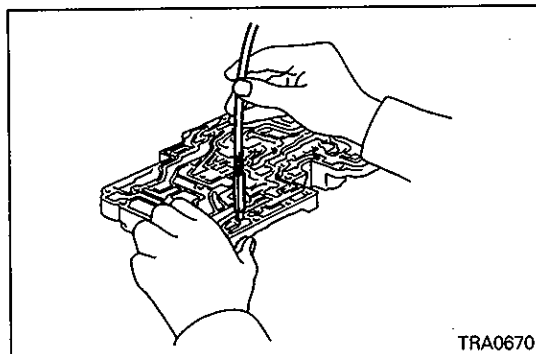

- (8) While pushing the sleeve with a finger, use a magnet to remove the seat.

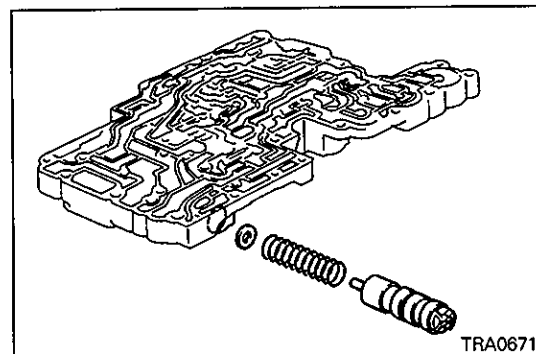

- (9) Remove the primary regulator valve sleeve and primary regulator valve plunger together and then remove the spring, washer and primary regulator valve.
 (10) Remove the primary regulator valve plunger from the primary regulator valve sleeve.

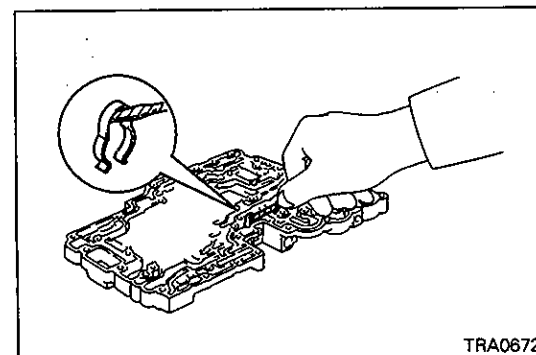

- (11) Using a screwdriver, remove the clip. <Up tp 1993 model>

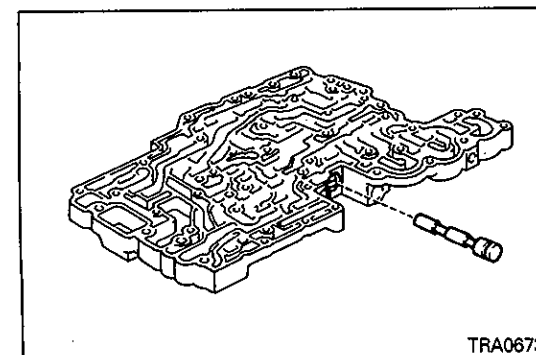

- (12) Remove the pressure reducing plug. <Up tp 1993 model>

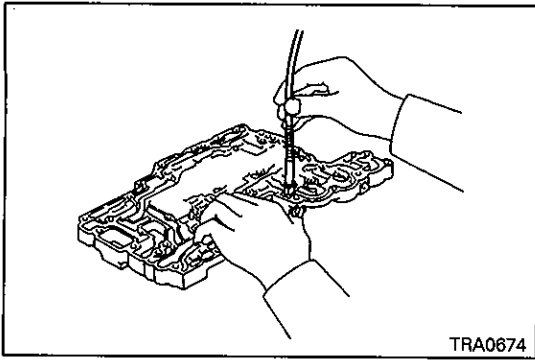

(13) While pushing the sleeve with a finger, use a magnet to remove the seat.

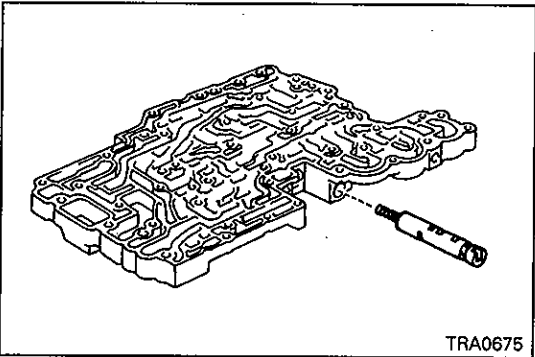

(14) Remove the accumulator control valve sleeve, accumulator control valve and spring together.

(15) Remove the spring and accumulator control valve from the accumulator control valve sleeve.

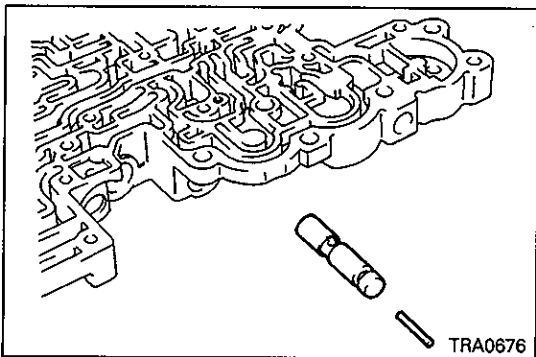

(16) Using a magnet, remove the pin.

(17) Remove the plug.

**INSPECTION
VALVE SPRING**

(1) Check the free height and outside diameter of each spring.

Standard value

Place \ Dimension	Free height	Outside diameter	Number of loops	Wire diameter
(1) 1-2 shift valve	30.8 (1.213)	9.7 (0.381)	8.5	0.9 (0.035)
(2) primary regulator valve*1	62.3 (2.453)	18.6 (0.732)	12.5	1.7 (0.067)
primary regulator valve*2	66.7 (2.626)	17.6 (0.693)	10.5	1.6 (0.063)
(3) accumulator control valve*3	33.9 (1.335)	8.8 (0.346)	10.0	0.8 (0.031)
accumulator control valve*4	29.8 (1.173)	8.8 (0.346)	16.0	0.8 (0.031)

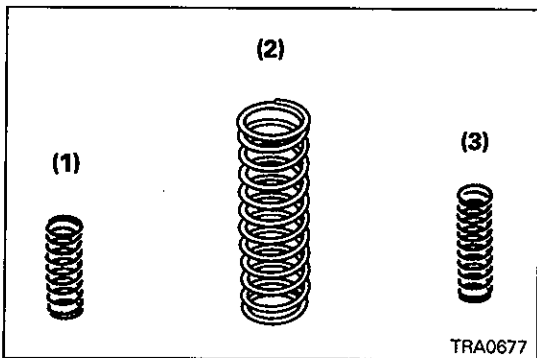

Unit of free height, outside diameter and wire diameter: mm (in.)

NOTE

*1: Except V4AW3-B-U

*2: V4AW3-B-U

*3: Except V4AW3-B-N, U

*4: V4AW3-B-N, U

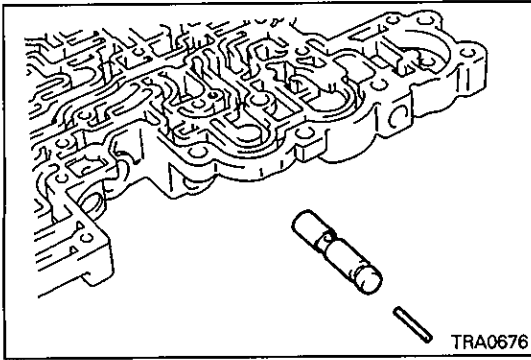
**REASSEMBLY**

- (1) Install the plug as illustrated.
- (2) Install the pin.

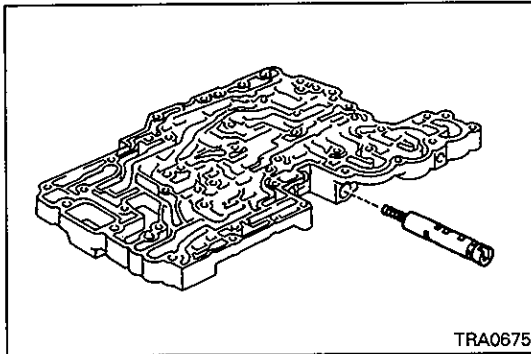

- (3) Install the accumulator control valve and spring to the accumulator control valve sleeve as illustrated.
- (4) Install the accumulator control valve sleeve, accumulator control valve and spring together.
- (5) While pushing the accumulator control valve sleeve with a finger, install the seat.

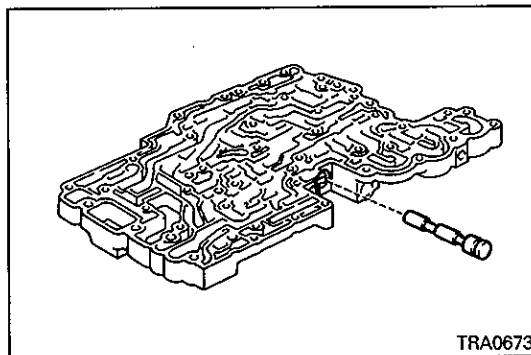

- (6) Install the pressure reducing plug as illustrated. <Up to 1993 model>

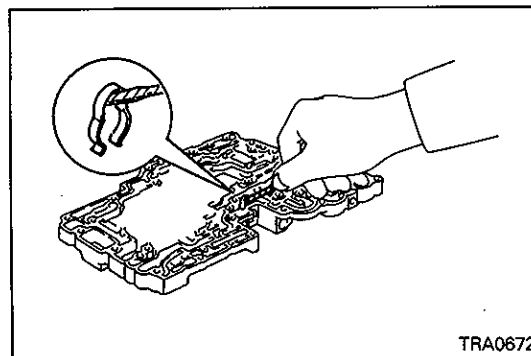

- (7) Install the clip along the groove of the pressure reducing plug. <Up to 1993 model>

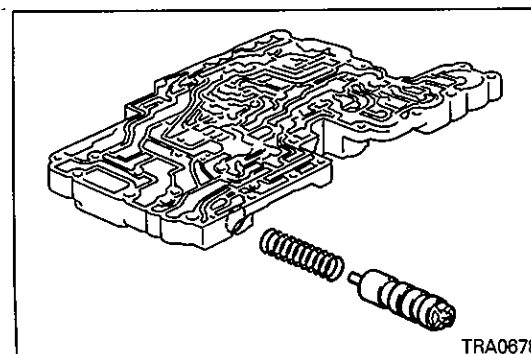

- (8) Install the washer to the primary regulator valve.
- (9) Install the washer and primary regulator valve together.
- (10) Install the primary regulator valve plunger to the pressure regulator valve sleeve as illustrated.
- (11) Install the spring, pressure regulator valve sleeve and primary regulator valve plunger together.

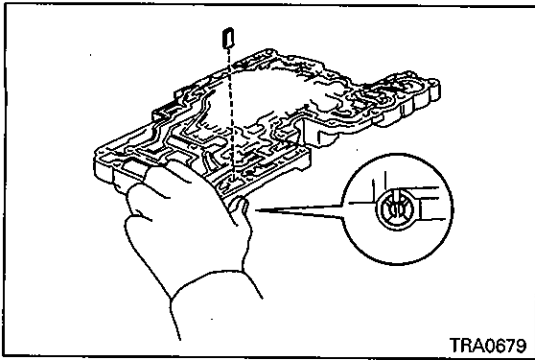

(12) While pushing the pressure regulator valve sleeve with a finger, install the seat.

Caution

- The seat must engage with the same groove of the primary regulator valve sleeve as before.

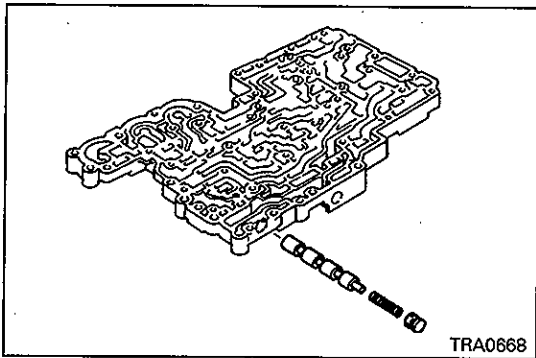

(13) Install the 1-2 shift valve, spring and plug as illustrated.
 (14) While pushing the plug, install the seat.

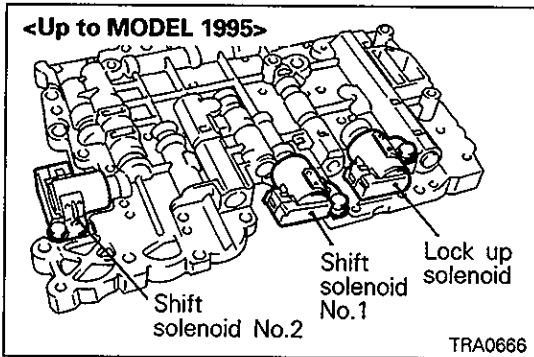

(15) Apply ATF to three new O-rings and install them to the solenoids respectively.

(16) Put the shift solenoids No.1, No.2 and lock up solenoid as illustrated and tighten the bolts.

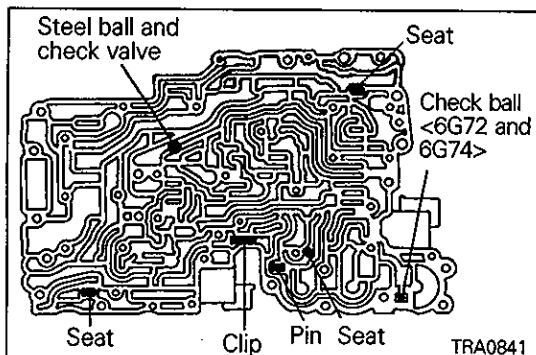
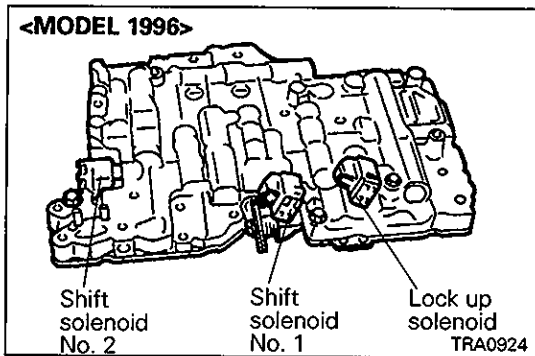

(17) Check that the three seats and one clip are installed as illustrated.

(18) Install the check ball. <6G72 and 6G74>

(19) Install the steel ball and check valve.

18. TRANSFER

DISASSEMBLY AND REASSEMBLY

<LHD>

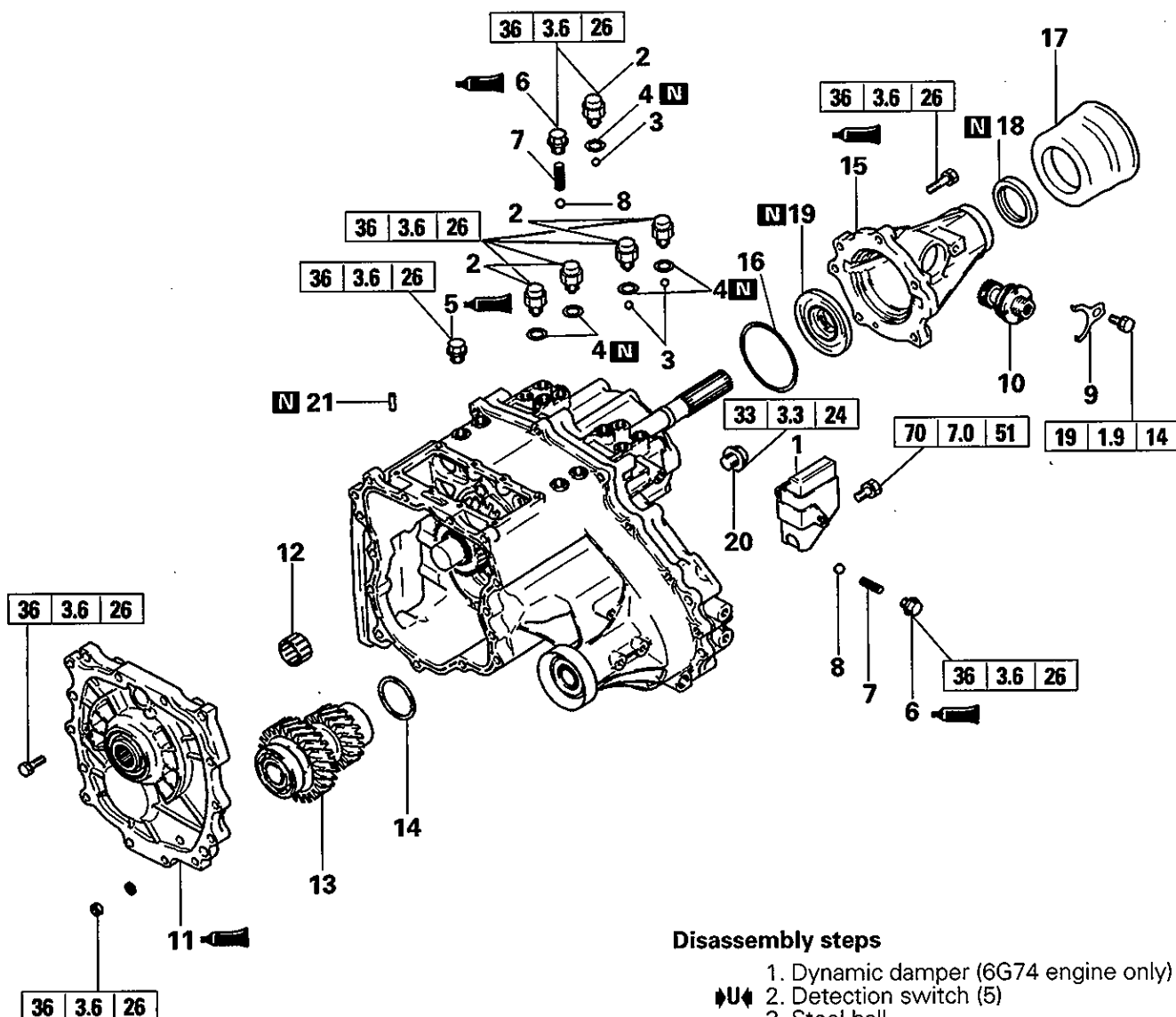

Lubricate all internal parts with gear oil during reassembly.

Disassembly steps

1. Dynamic damper (6G74 engine only)
- ♦U♦ 2. Detection switch (5)
3. Steel ball
4. Gasket
- ♦T♦ 5. Plug (7)
- ♦S♦ 6. Poppet plug
- ♦R♦ 7. Poppet spring
8. Steel ball
9. Sleeve clamp
- ♦Q♦ 10. Speedometer gear assembly
- ♦P♦ 11. Transfer case plate
12. Needle bearing
13. Countershaft gear
- ♦O♦ 14. Spacer
- ♦N♦ 15. Rear cover
- ♦M♦ 16. Spacer
17. Dust seal guard
- ♦L♦ 18. Oil seal
- ♦K♦ 19. Oil seal
20. H-L shift rail plug
- ♦J♦ 21. Spring pin (H-L shift fork)

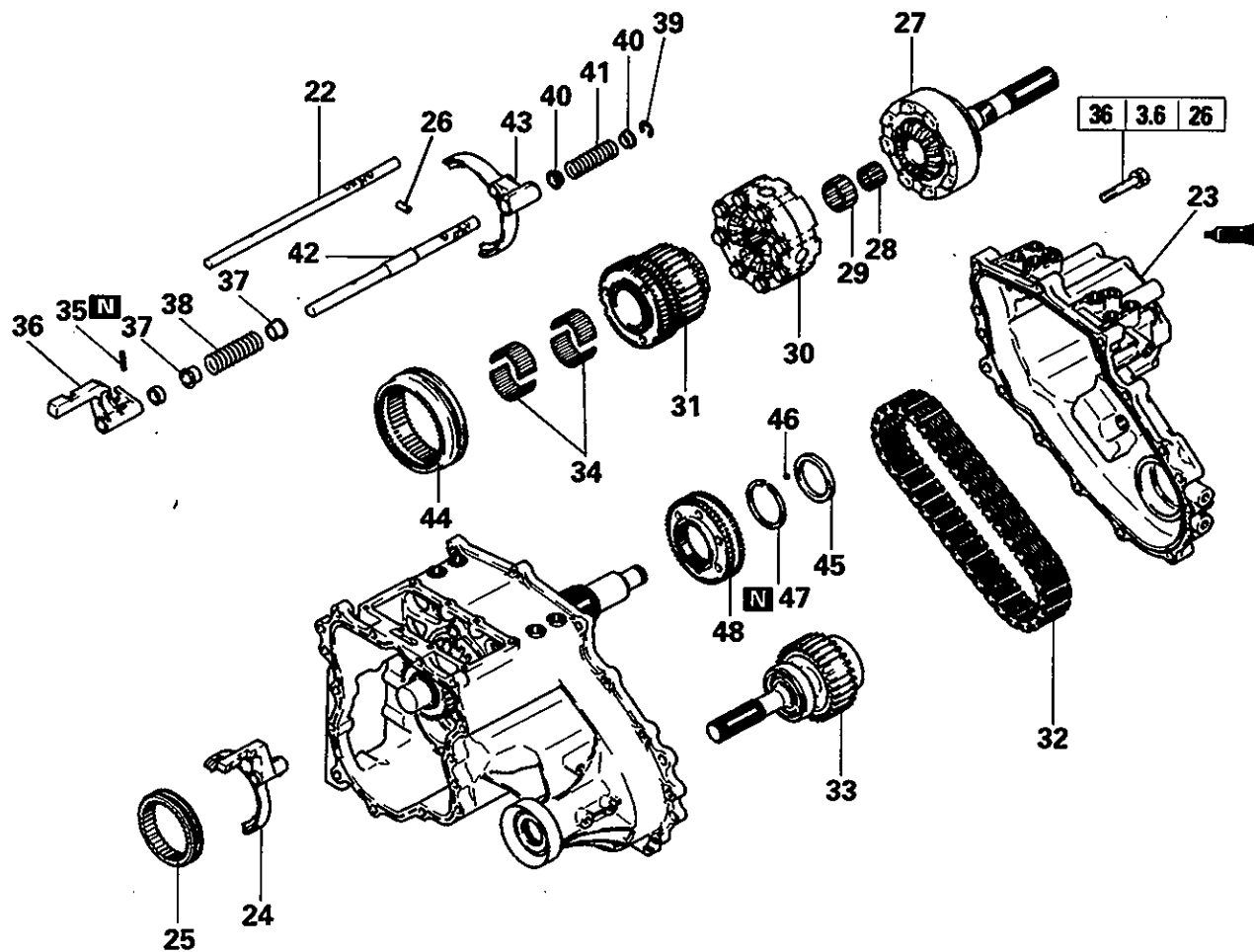

 Lubricate all internal parts with gear oil during reassembly.

Disassembly steps

- ◇A◇▶J▶ 22. H-L shift rail
- ◇A◇▶I▶ 23. Chain cover
- 24. H-L shift fork
- 25. H-L clutch sleeve
- ▶I▶ 26. Interlock plunger
- 27. Rear output shaft
- 28. Needle bearing
- 29. Needle bearing
- 30. Center differential case
- ◇B◇▶H▶ 31. 2-4WD synchronizer
- ◇B◇▶H▶ 32. Chain
- ◇B◇▶H▶ 33. Front output shaft
- 34. Needle bearing
- ◇C◇▶G▶ 35. Spring pin (2-4WD shift lug)
- ▶G▶ 36. 2-4WD shift lug
- ▶G▶ 37. Spring seat
- ▶G▶ 38. Spring
- 39. E-ring
- 40. Spring seat
- 41. Spring
- ▶G▶ 42. 2-4WD shift rail
- 43. 2-4WD shift fork
- 44. 2-4WD synchronizer sleeve
- 45. Sleeve
- 46. Steel ball
- ▶F▶ 47. Snap ring
- 48. Differential lock hub

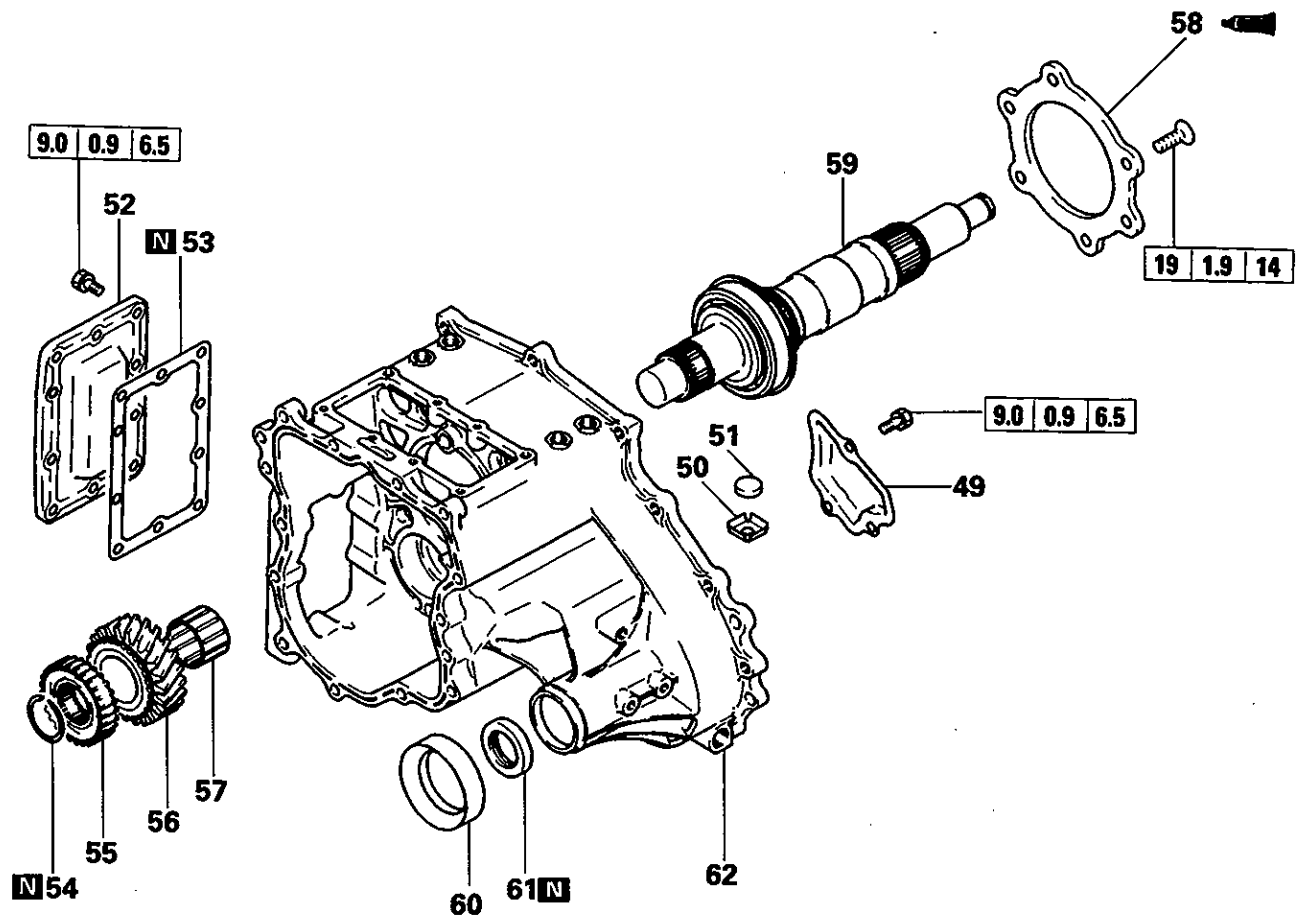

Disassembly steps

- 49. Oil pool cover
- ◆E◆ 50. Magnet holder
- ◆E◆ 51. Magnet
- 52. Side cover
- 53. Side cover gasket
- ◆D◆ 54. Snap ring
- ◆C◆ 55. H-L clutch hub
- 56. Low speed gear
- 57. Needle bearing
- ◆B◆ 58. Rear bearing retainer
- 59. Transfer drive shaft
- 60. Dust seal guard
- ◆A◆ 61. Oil seal
- 62. Transfer case

 Lubricate all internal parts with gear oil during reassembly.

<RHD>

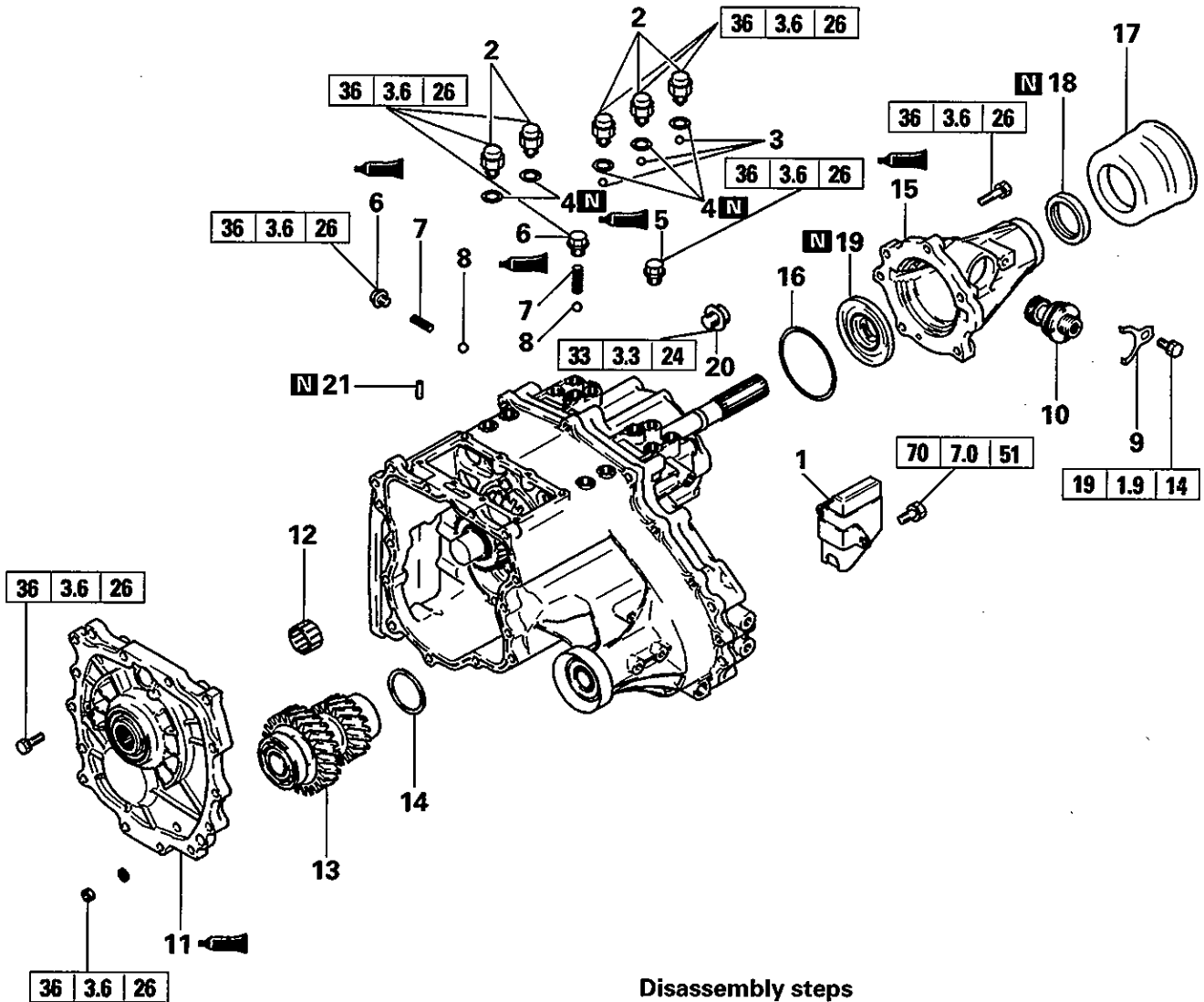

Disassembly steps

- 1. Dynamic damper (6G74 engine only)
- ➔U 2. Detection switch (5)
- 3. Steel ball
- 4. Gasket
- ➔T 5. Plug (7)
- ➔S 6. Poppet plug
- ➔R 7. Poppet spring
- 8. Steel ball
- 9. Sleeve clamp
- ➔Q 10. Speedometer gear assembly
- ➔P 11. Transfer case plate
- 12. Needle bearing
- 13. Countershaft gear
- ➔O 14. Spacer
- ➔N 15. Rear cover
- ➔M 16. Spacer
- 17. Dust seal guard
- ➔L 18. Oil seal
- ➔K 19. Oil seal
- 20. H-L shift rail plug
- ➔J 21. Spring pin (H-L shift fork)

 Lubricate all internal parts with gear oil during reassembly.

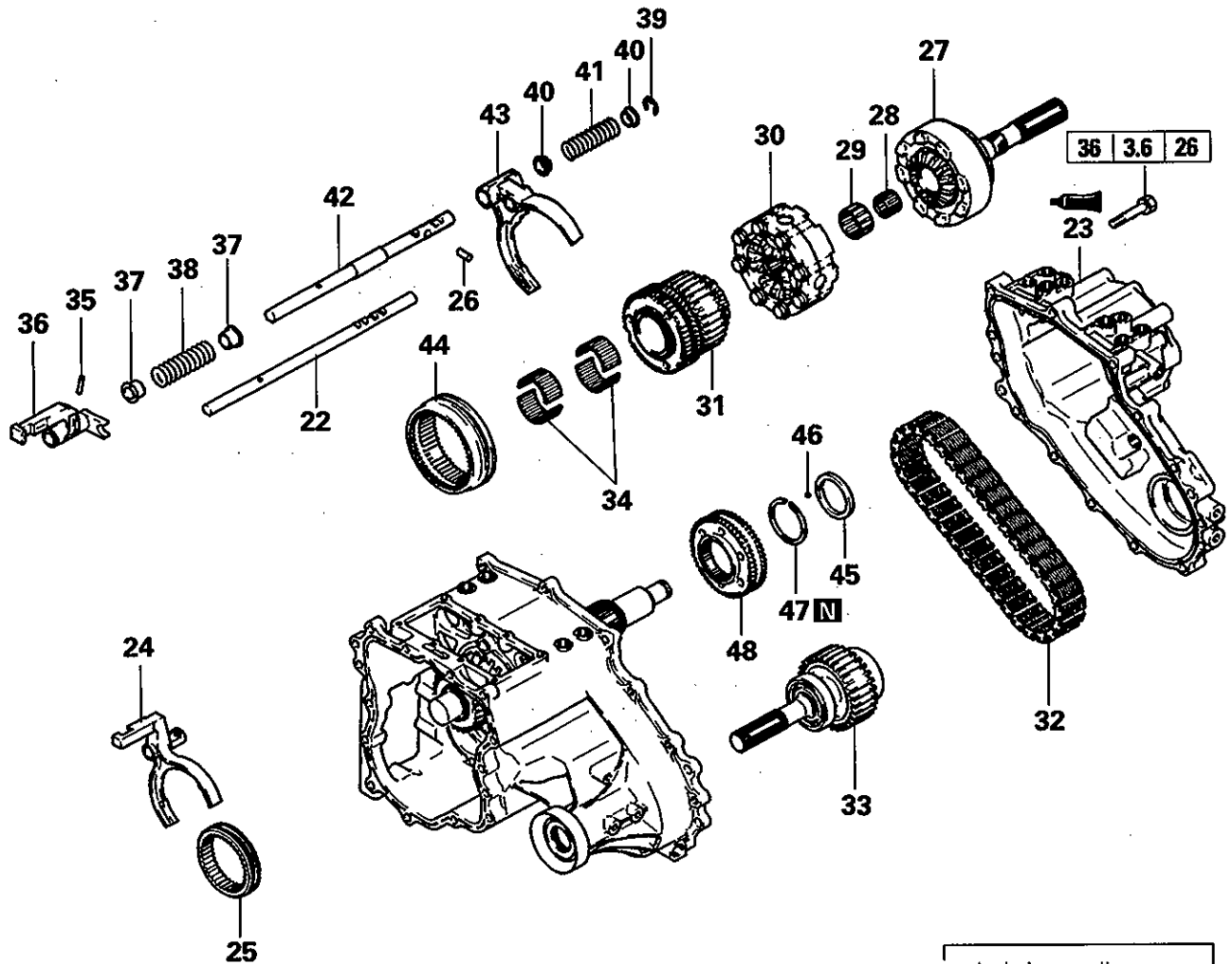

 Lubricate all internal parts with gear oil during reassembly.

Disassembly steps

- ◊A◊ ▶J◊ 22. H-L shift rail
- ◊A◊ ▶I◊ 23. Chain cover
- ▶I◊ 24. H-L shift fork
- ▶I◊ 25. H-L clutch sleeve
- ▶I◊ 26. Interlock plunger
- ▶I◊ 27. Rear output shaft
- ▶I◊ 28. Needle bearing
- ▶I◊ 29. Needle bearing
- ▶I◊ 30. Center differential case
- ◊B◊ ▶H◊ 31. 2-4WD synchronizer
- ◊B◊ ▶H◊ 32. Chain
- ◊B◊ ▶H◊ 33. Front output shaft
- ▶I◊ 34. Needle bearing
- ◊C◊ ▶G◊ 35. Spring pin (2-4WD shift lug)

- ▶G◊ 36. 2-4WD shift lug
- ▶G◊ 37. Spring seat
- ▶G◊ 38. Spring
- ▶I◊ 39. E-ring
- ▶I◊ 40. Spring seat
- ▶I◊ 41. Spring
- ▶G◊ 42. 2-4WD shift rail
- ▶I◊ 43. 2-4WD shift fork
- ▶I◊ 44. 2-4WD synchronizer sleeve
- ▶I◊ 45. Sleeve
- ▶I◊ 46. Steel ball
- ▶F◊ 47. Snap ring
- ▶I◊ 48. Differential lock hub

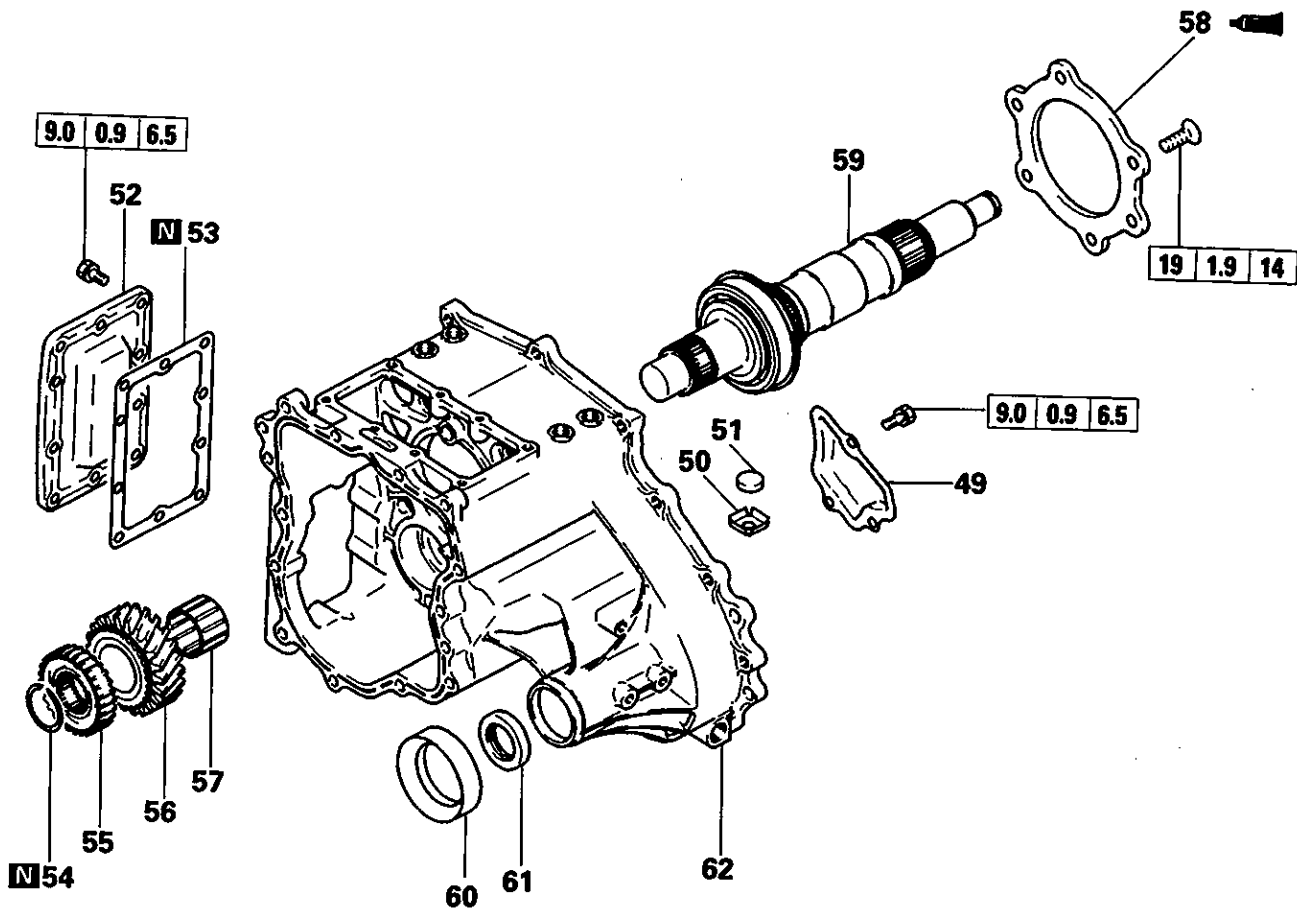

Disassembly steps

- 49. Oil pool cover
- ◆E◆ 50. Magnet holder
- ◆E◆ 51. Magnet
- 52. Side cover
- 53. Side cover gasket
- ◆D◆ 54. Snap ring
- ◆C◆ 55. H-L clutch hub
- 56. Low speed gear
- 57. Needle bearing
- ◆B◆ 58. Rear bearing retainer
- 59. Transfer drive shaft
- 60. Dust seal guard
- ◆A◆ 61. Oil seal
- 92. Transfer case

 Lubricate all internal parts with gear oil during reassembly.

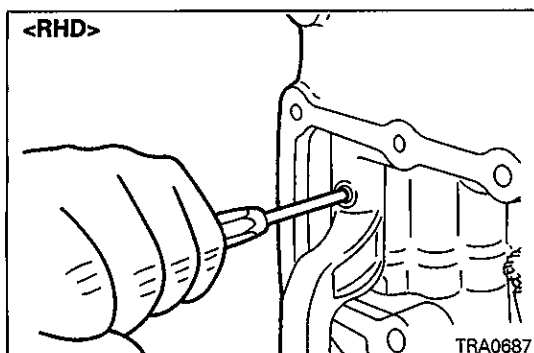
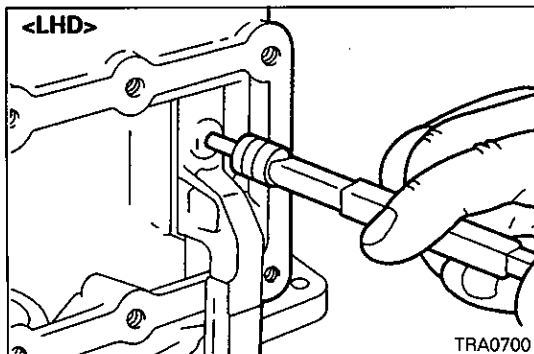
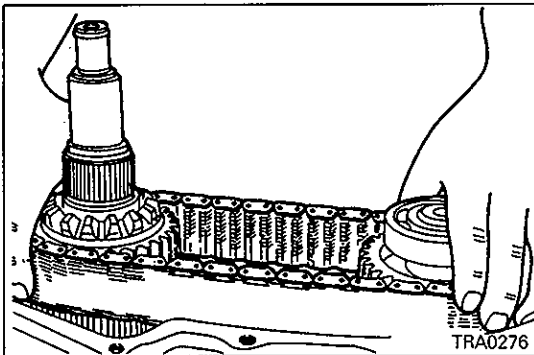
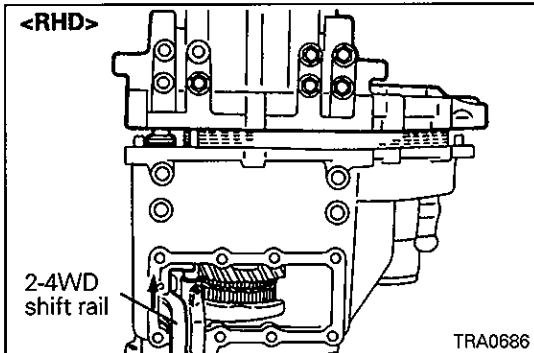
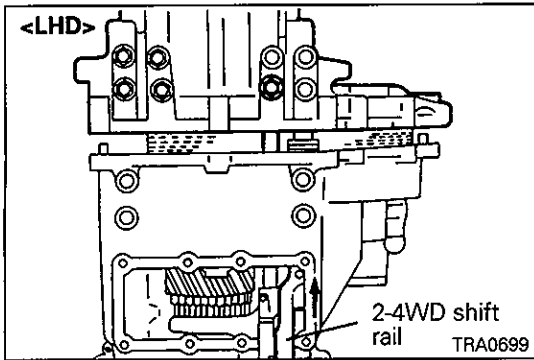

DISASSEMBLY SERVICE POINTS

◊A◊ H-L SHIFT RAIL / CHAIN COVER REMOVAL

- (1) Fix the H-L shift rail at the High side.
- (2) Place the 2-4WD shift rail at the 4WD position.

NOTE

If the 2-4WD shift rail is placed at the 2WD position, the chain cover cannot be removed because of interlocking.

- (3) Remove the chain cover and remove H-L shift rail.

◊B◊ 2-4WD SYNCHRONIZER / CHAIN / FRONT OUTPUT SHAFT REMOVAL

- (1) Remove the 2-4WD synchronizer, chain and front output shaft as a set.

◊C◊ SPRING PIN REMOVAL

Caution

- The spring may fly out.

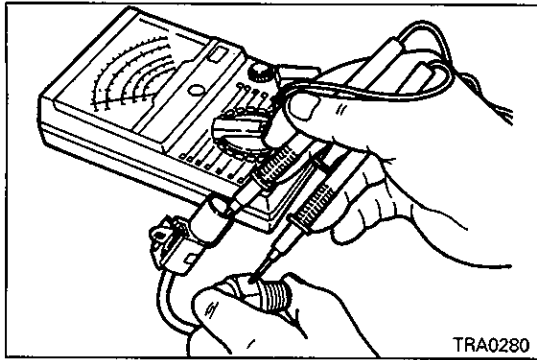

**INSPECTION
DETECTION SWITCH**

- (1) Check for continuity between the connector terminal and switch body.

Switch state	Continuity
Switch end pressed	No
Switch end released	Yes

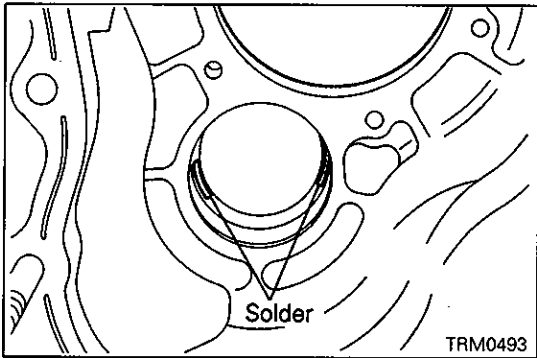

**ADJUSTMENT BEFORE REASSEMBLY
SPACER SELECTION FOR ADJUSTMENT OF COUNTER-SHAFT GEAR END PLAY**

- (1) Place a solder bar (about 10 mm in length and 1.6 mm in diameter) on the transfer case as illustrated.
 (2) Install the countershaft gear and transfer case plate and tighten the bolts to the specified torque.
 (3) If the solder is not deformed, repeat the steps (1) and (2) using a thicker solder bar.

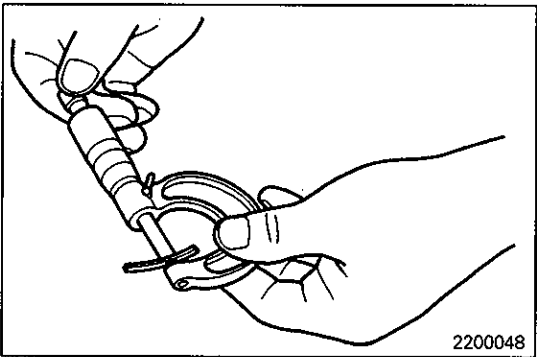

- (4) Using a micrometer, measure the thickness of the crushed solder bar. Based on the result, select a spacer which adjust the end play to the standard value shown below:

Standard value: 0 – 0.15 mm (0 – 0.0006 in.)

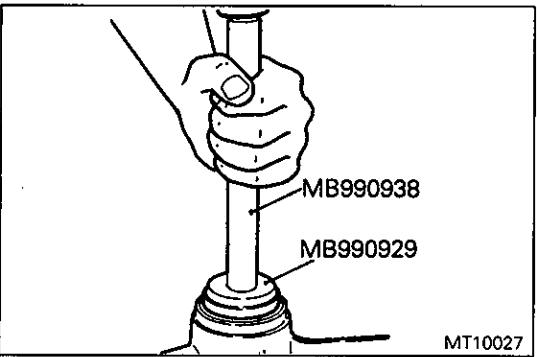

REASSEMBLY SERVICE POINTS

◆A◆ OIL SEAL INSTALLATION

- (1) Apply gear oil to the lip of the oil seal after press-fitting.

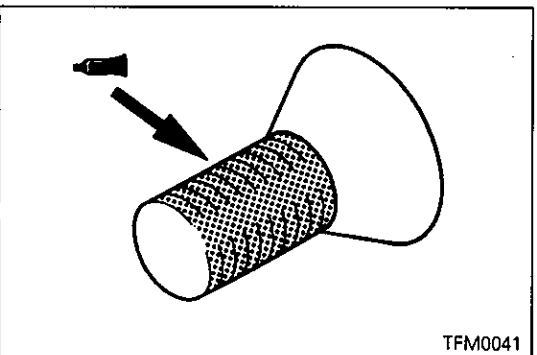

◆B◆ REAR BEARING RETAINER INSTALLATION

- (1) The rear bearing retainer screw is a precoated screw. When it is to be reused, apply sealant beforehand.

**Specified sealant:
3M STUD Locking No. 4170 or equivalent**

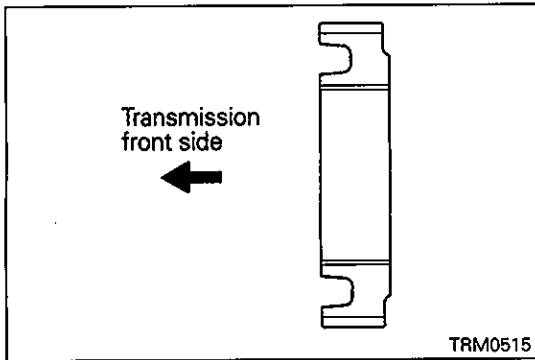

▶◀ H-L CLUTCH HUB INSTALLATION

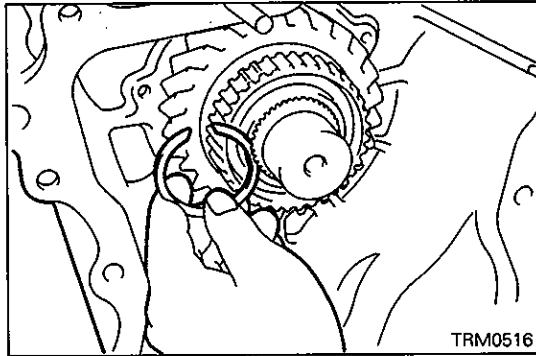

▶◀ SNAP RING INSTALLATION

- (1) Select and install the snap ring which adjusts the H-L clutch hub end play to the standard value.

Standard value: 0 – 0.08 mm (0 – 0.0031 in.)

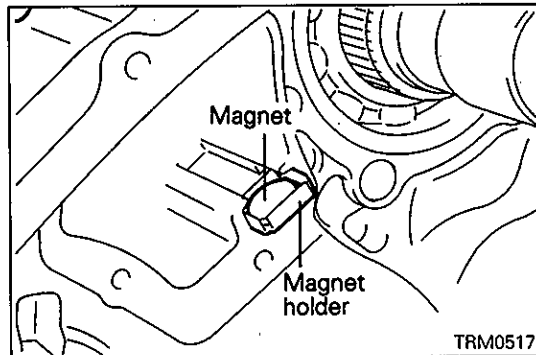

▶◀ MAGNET / MAGNET HOLDER INSTALLATION

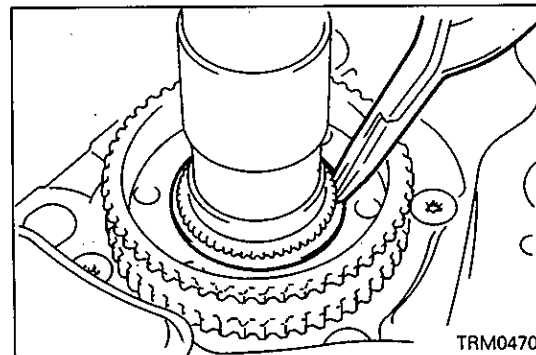

▶◀ SNAP RING INSTALLATION

- (1) Select a snap ring which adjusts the differential lock hub end play to the standard value shown below:

Standard value: 0 – 0.08 mm (0 – 0.0031 in.)

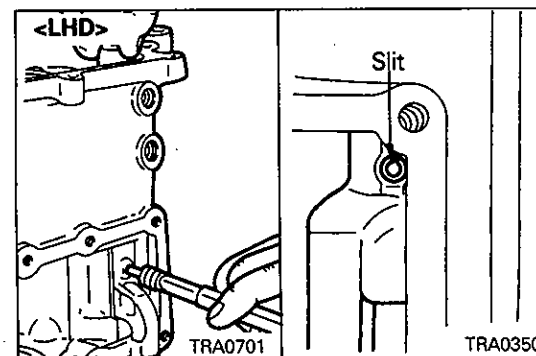

▶◀ 2-4WD SHIFT RAIL / 2-4WD SHIFT LUG / SPRING SEAT / SPRING / SPRING PIN INSTALLATION

- (1) Slide the spring seats and spring over the shift rail and set the shift lug in position in the transfer case.
- (2) While paying attention to the direction of the shift rail, insert the shift rail in the shift lug and line up the shift lug and shift rail spring pin holes.
- (3) While pressing the rail, install the spring pin in such a way that the slit of the spring pin will face the axial center of the shift rail.

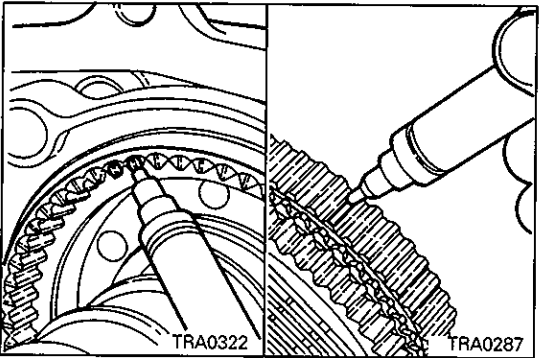
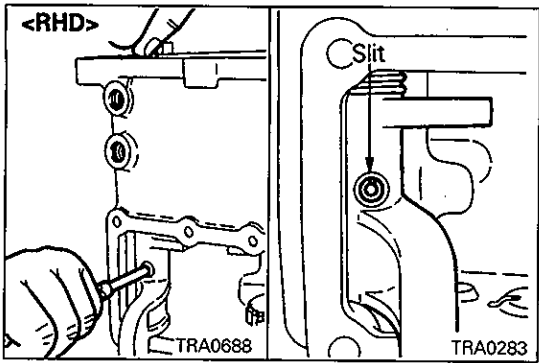

▶H◀ FRONT OUTPUT SHAFT / CHAIN / 2-4WD SYNCHRONIZER INSTALLATION

- (1) Make a white paint mark on the deep groove portions (three places) of the 2-4WD synchronizer.
- (2) Make a white paint mark on the projections (three places) of the 2-4WD synchronizer sleeve splines.

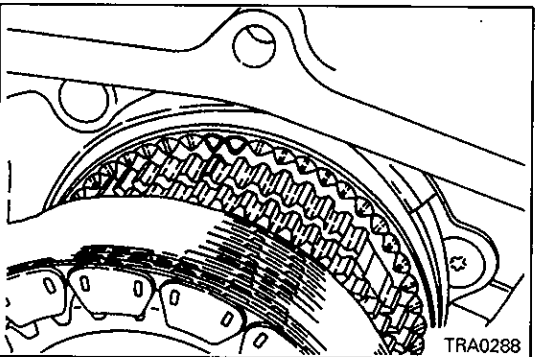

- (3) Place the chain in tight mesh with the 2-4WD synchronizer and front output shaft sprockets.
- (4) With both sprockets spaced the farthest apart, install them on the transfer case simultaneously.

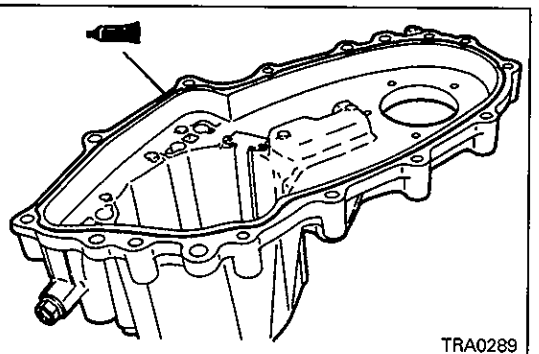

▶I◀ INTERLOCK PLUNGER / CHAIN COVER INSTALLATION

- (1) Insert the interlock plunger into a position where it does not interfere with the 2-4WD shift rail.
- (2) Apply a sealant to the illustrated position of the chain cover.

Specified sealant:

Mitsubishi genuine sealant Part No. MD997740 or equivalent

Caution

- Squeeze the sealant out evenly to make sure that it is not broken or excessively supplied.

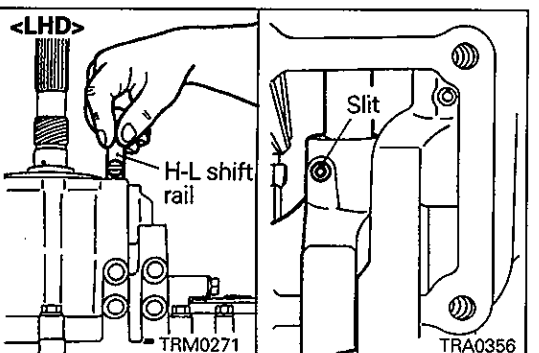

▶J◀ H-L SHIFT RAIL / SPRING PIN INSTALLATION

- (1) Insert the H-L shift rail in the transfer case, while paying attention to its direction.
- (2) Line up the shift rail and shift fork spring pin holes and install the spring pin so that the slit of the spring pin will face the axial center of the shift rail.

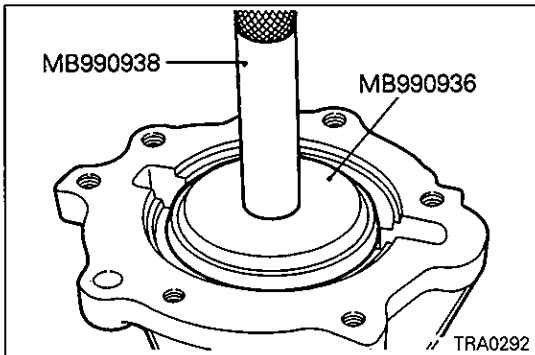
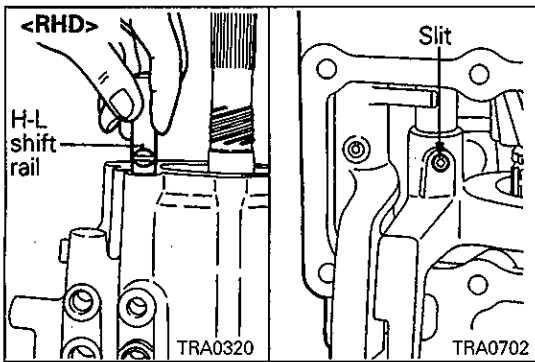

▶K◀ OIL SEAL INSTALLATION

- (1) Apply gear oil to the lip of the oil seal after press-fitting.

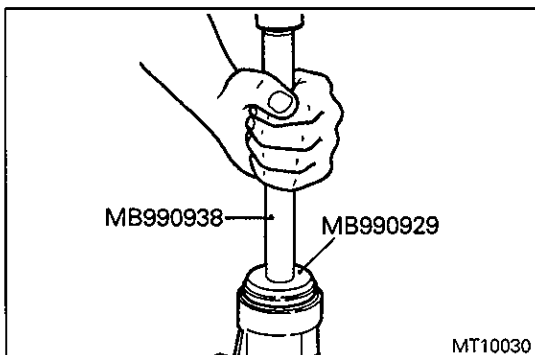

▶L◀ OIL SEAL INSTALLATION

- (1) Apply gear oil to the lip of the oil seal after press-fitting.

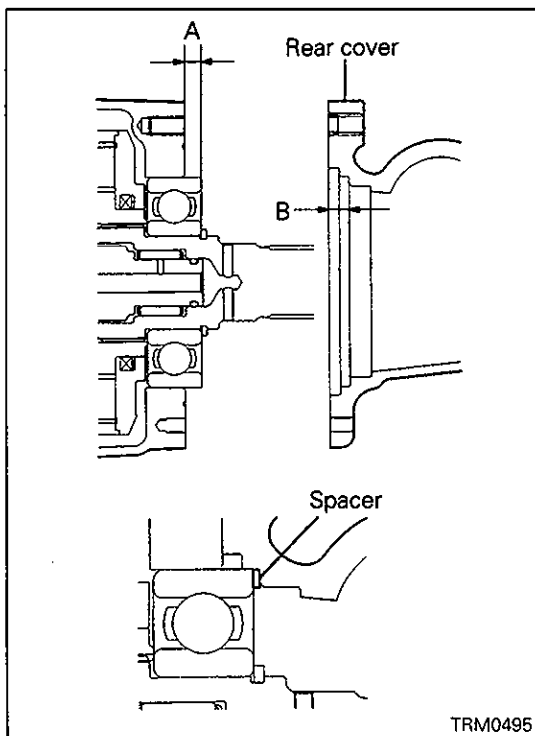

▶M◀ SPACER INSTALLATION

- (1) Measure projection "A" of the rear output shaft bearing and depth "B" to the second stage in the rear cover recess.
- (2) Subtract A from B and let the answer be C. Subtract the thickness of the spacer from C, and select a spacer so that the subtracted value will be the standard value shown below.

Standard value: 0.025 – 0.150 mm (0.00098 – 0.00591 in.)

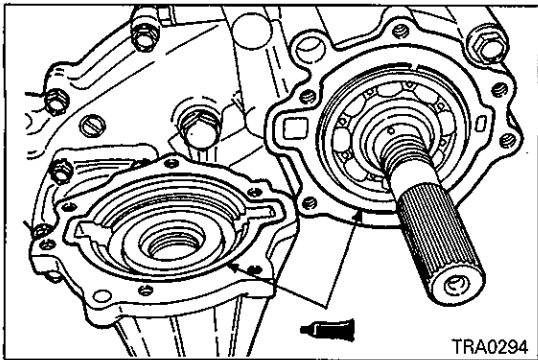

▶N◀ REAR COVER INSTALLATION

- (1) Apply sealant to the rear cover as illustrated.

Specified sealant:

Mitsubishi genuine sealant Part No. MD997740 or equivalent

Caution

- Squeeze the sealant out evenly to make sure that it is not broken or excessively supplied.

▶O◀ SPACER INSTALLATION

- (1) Install the previously selected spacer (see "ADJUSTMENT BEFORE REASSEMBLY").

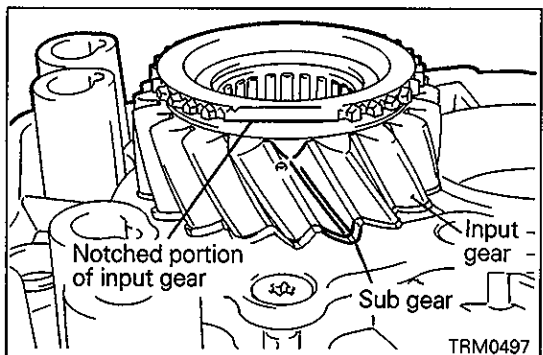

▶P◀ TRANSFER CASE PLATE INSTALLATION

- (1) Align one of the sub gear teeth with the notched tooth of the input gear.

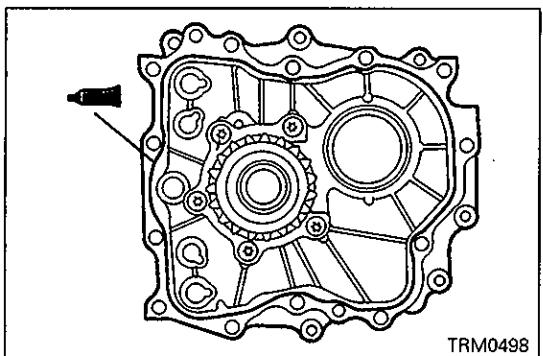

- (2) Apply a bead of sealant to the transfer case plate as illustrated.

Specified sealant:

Mitsubishi genuine sealant Part No. MD997740 or equivalent

Caution

- Squeeze the sealant out evenly to make sure that it is not broken or excessively supplied.
- (3) Install the transfer case plate together with the input gear, while sliding the input gear tooth aligned in Step (1) along the tooth space of the countershaft cluster gear.

NOTE

The transfer case plate must be installed smoothly without hitch.

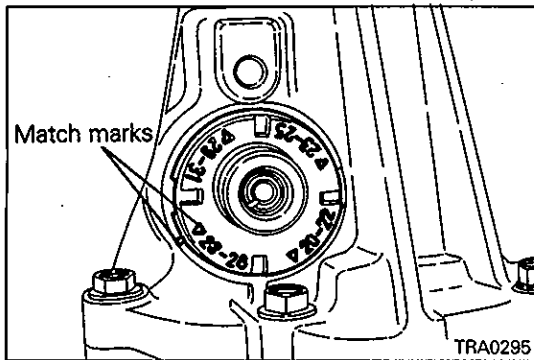

◆Q◆ SPEEDOMETER GEAR INSTALLATION

- (1) Align the match marks according to the number of teeth.

Caution

- The number marked on the sleeve is the number of teeth of the driven gear.

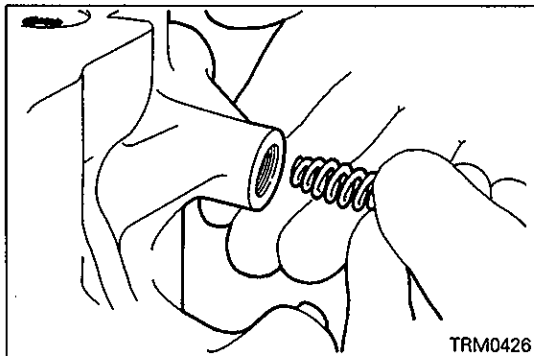

◆R◆ POPPET SPRING INSTALLATION

- (1) Install the spring with its tapered end oriented to the ball side.

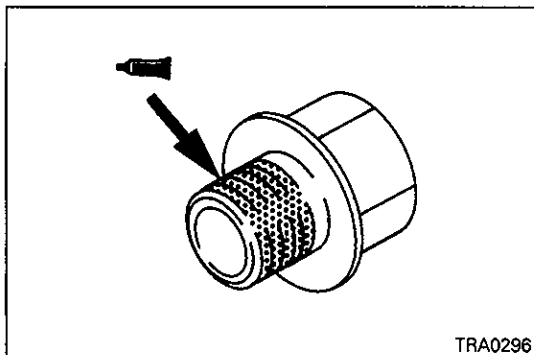

◆S◆ POPPET PLUG INSTALLATION

- (1) The poppet plug is a precoated plug. When it is to be reused, apply sealant beforehand.

Specified sealant: 3M ATD Part No. 8660 or equivalent

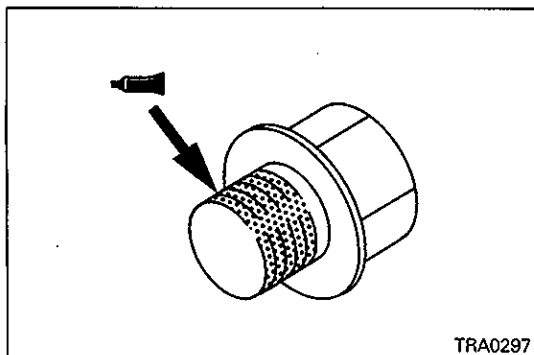

◆T◆ PLUG INSTALLATION

- (1) The plug is precoated. When it is to be reused, apply sealant beforehand.

Specified sealant: 3M ATD Part No. 8660 or equivalent

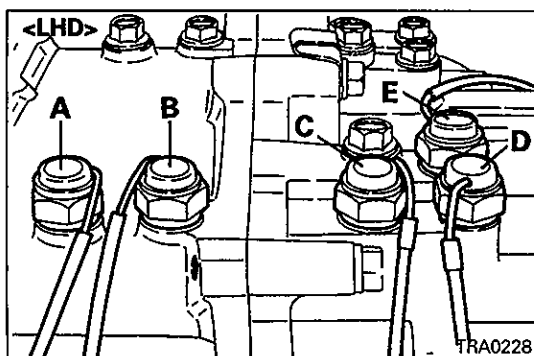

◆U◆ DETECTION SWITCH INSTALLATION

- (1) Mount detection switches in the right positions, while using care to prevent confusion.

- A: Ball built in, connector brown
- B: Ball built in, connector black
- C: Ball separate, connector brown
- D: Ball separate, connector black
- E: Ball separate, connector white

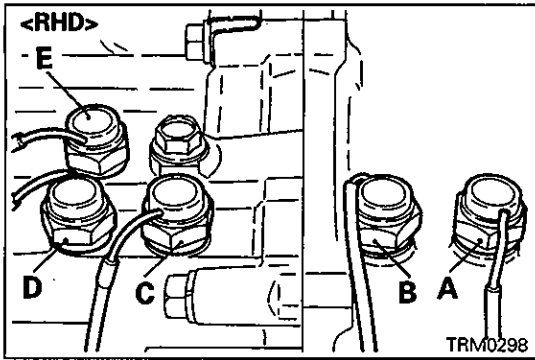

19. TRANSFER CASE PLATE

DISASSEMBLY AND REASSEMBLY

 Lubricate all internal parts with gear oil during reassembly.

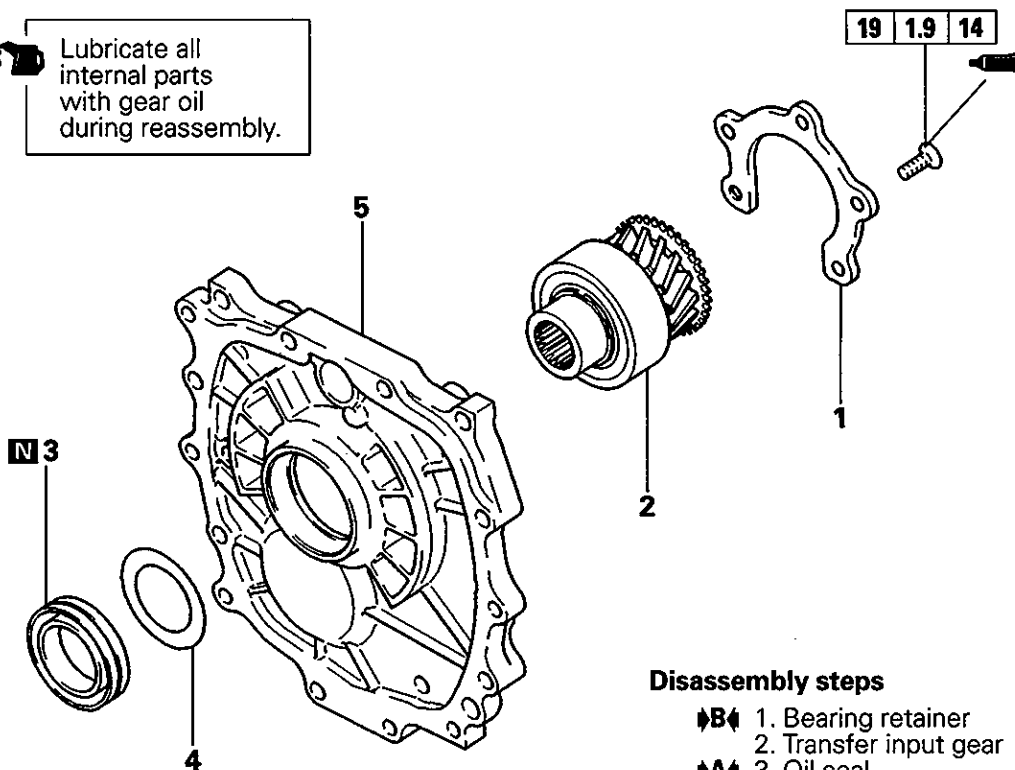

Disassembly steps

- ▶B◀ 1. Bearing retainer
- ▶B◀ 2. Transfer input gear
- ▶A◀ 3. Oil seal
- ▶A◀ 4. Baffle plate
- ▶A◀ 5. Transfer case plate

TRA0690

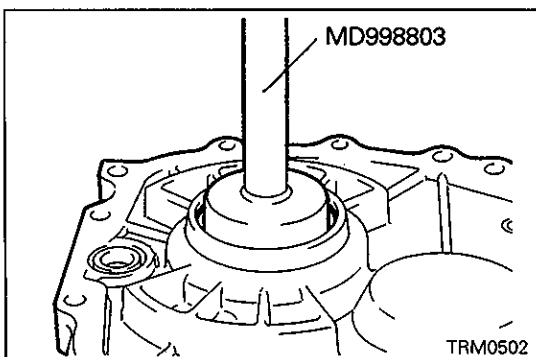

REASSEMBLY SERVICE POINTS

▶A◀ OIL SEAL INSTALLATION

- (1) After installing, apply gear oil to the lip of the oil seal.

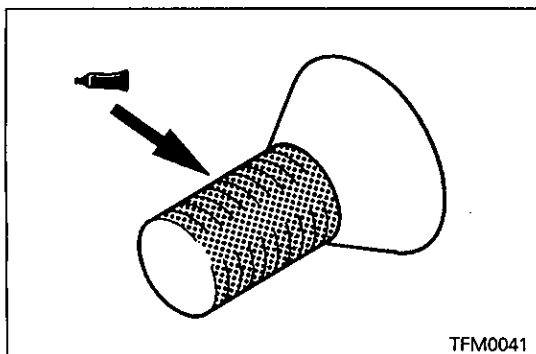

▶B◀ BEARING RETAINER INSTALLATION

- (1) The rear bearing retainer bolt is a precoated bolt. When it is to be reused, apply sealant beforehand.

Specified sealant:

Mitsubishi genuine sealant Part No. MD997740 or equivalent

NOTES

20. TRANSFER INPUT GEAR DISASSEMBLY AND REASSEMBLY



Lubricate all internal parts with gear oil during reassembly.

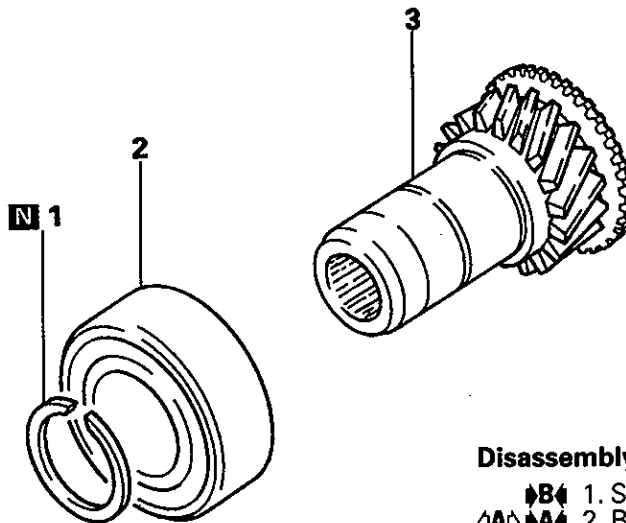

Disassembly steps

- ▶B▶ 1. Snap ring
- ◀A▶▶A▶ 2. Ball bearing
- 3. Transfer input gear

145086

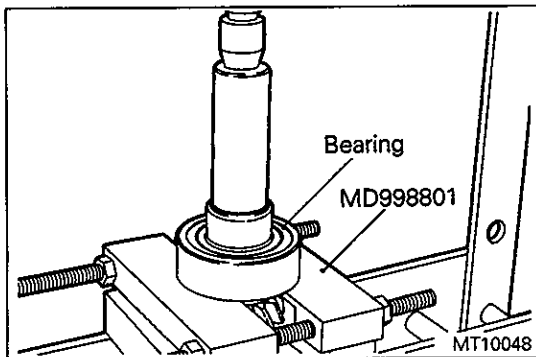

DISASSEMBLY SERVICE POINT

◀A▶ BALL BEARING REMOVAL

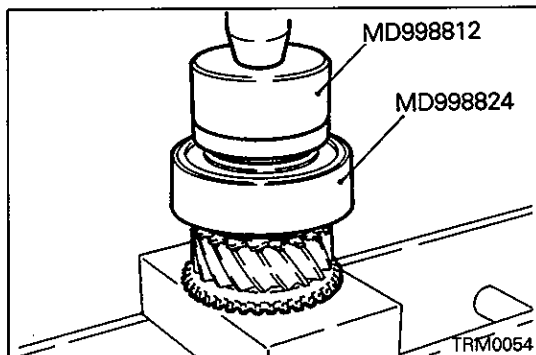

REASSEMBLY SERVICE POINTS

▶A▶ BALL BEARING INSTALLATION

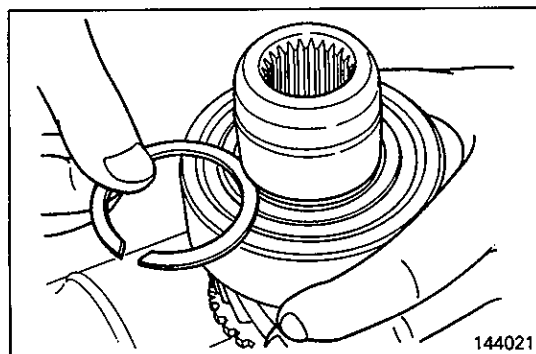

▶B▶ SNAP RING INSTALLATION

- (1) Select and install the snap ring which adjust the transfer input gear bearing end play to the standard value.

Standard value: 0 – 0.06 mm (0 – 0.0024 in.)

NOTES

21. COUNTERSHAFT GEAR DISASSEMBLY AND REASSEMBLY

Lubricate all internal parts with gear oil during reassembly.

N 2

Disassembly steps

- ◁A▷ ▷C◁ 1. Ball bearing
- ▷B◁ 2. Snap ring
- ◁B▷ ▷A◁ 3. Roller bearing
- 4. Countershaft gear

TRM0504

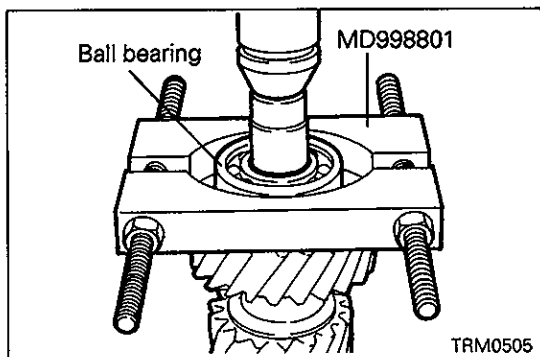

DISASSEMBLY SERVICE POINT

◁A▷ **BALL BEARING REMOVAL**

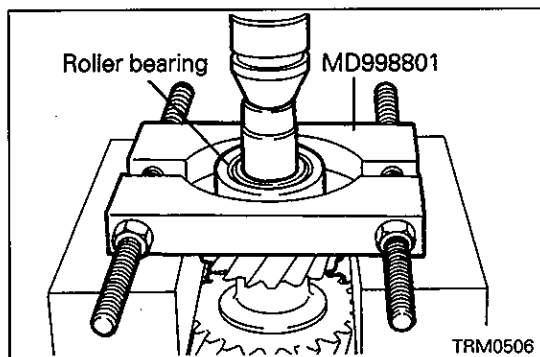

◁B▷ **ROLLER BEARING REMOVAL**

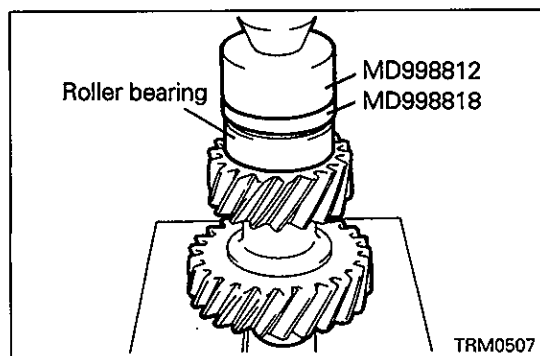

REASSEMBLY SERVICE POINTS

▷A◁ **ROLLER BEARING INSTALLATION**

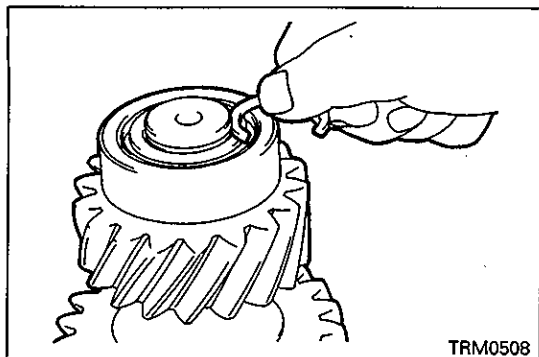

TRM0508

▶B▶ SNAP RING INSTALLATION

- (1) Select a snap ring that adjusts the end play of the countershaft gear roller bearing to the standard value shown below:

Standard value: 0 – 0.08 mm (0 – 0.0031 in.)

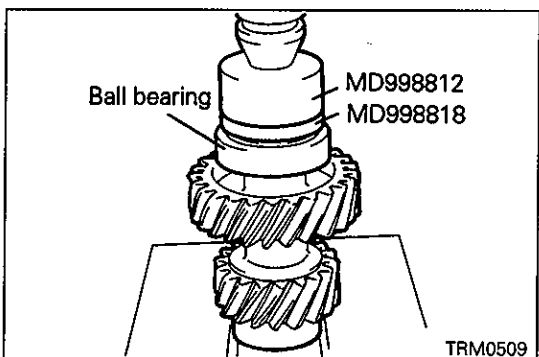

TRM0509

▶C▶ BALL BEARING INSTALLATION

22.2-4WD SYNCHRONIZER DISASSEMBLY AND REASSEMBLY

 Lubricate all internal parts with gear oil during reassembly.

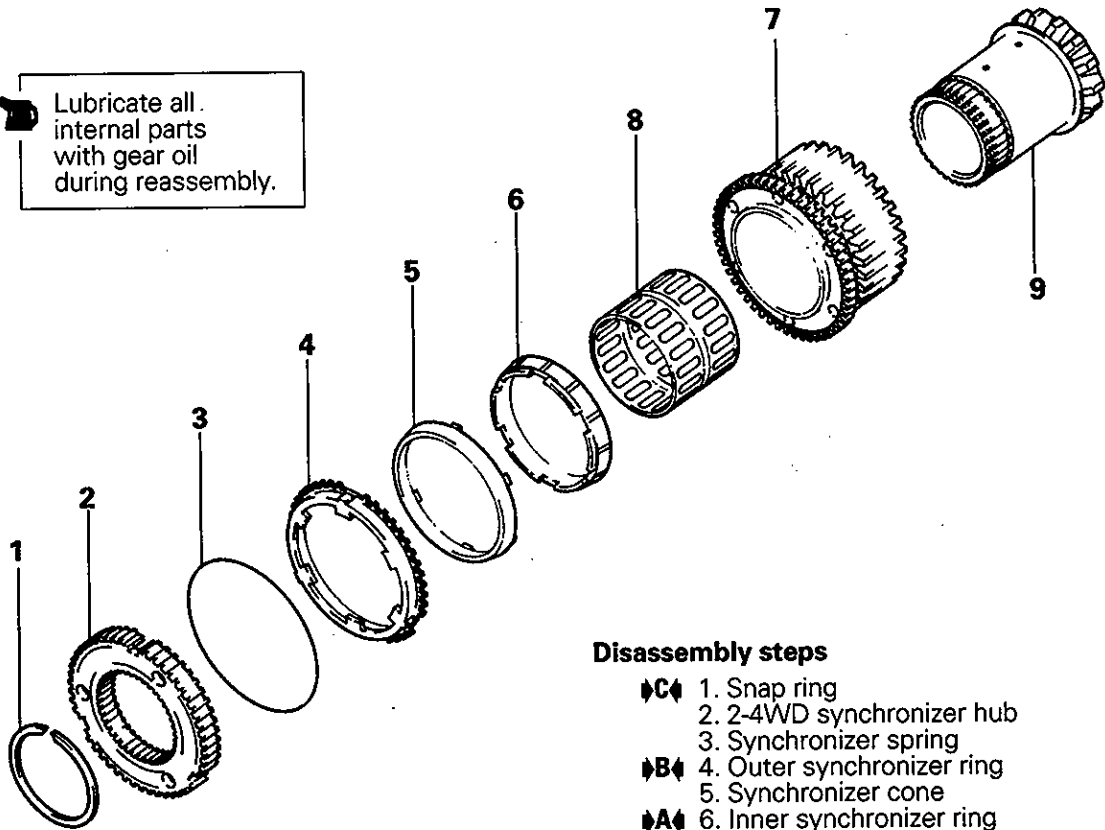

Disassembly steps

- ▶C▶ 1. Snap ring
- 2. 2-4WD synchronizer hub
- 3. Synchronizer spring
- ▶B▶ 4. Outer synchronizer ring
- 5. Synchronizer cone
- ▶A▶ 6. Inner synchronizer ring
- 7. Drive sprocket
- 8. Needle bearing
- 9. Front side gear

TRA0307

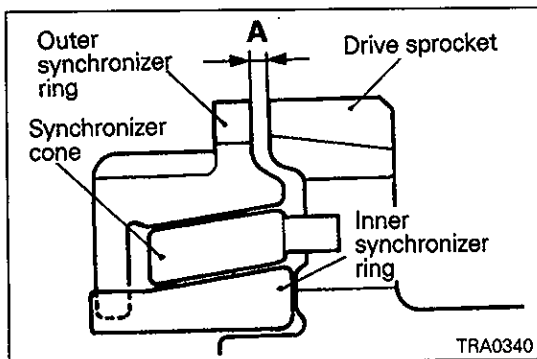

TRA0340

INSPECTION

SYNCHRONIZER RING AND SYNCHRONIZER CONE

- (1) Combine the inner and outer synchronizer rings and cone with the drive sprocket and measure the dimension A in the illustration. If the dimension A is less than the limit, replace them as a set.

Limit: 0.3 mm (0.012 in.)

NOTE

Scratches may be found on the cone surface in the rotating direction these are produced by the liners of the synchronizer rings and do not mean the malfunction. Therefore, the parts need not be replaced if the above-mentioned clearance is satisfied.

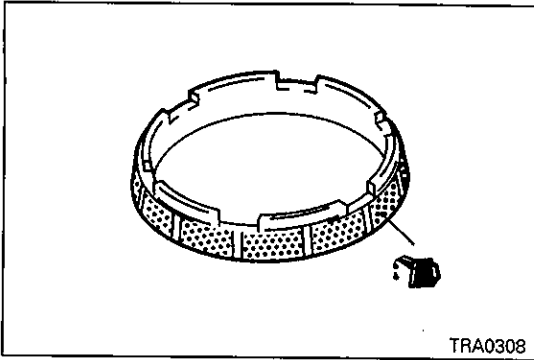

REASSEMBLY SERVICE POINTS

▶A◀ INNER SYNCHRONIZER RING INSTALLATION

- (1) Apply gear oil to the synchronizer ring cone surface before installation.

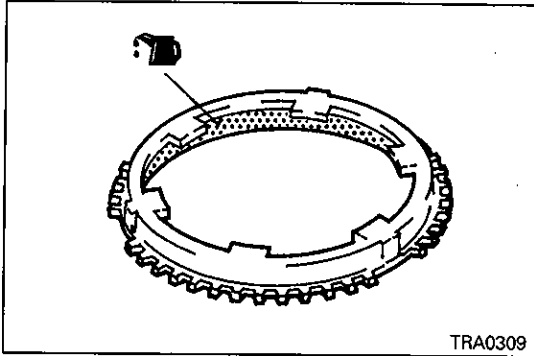

▶B◀ OUTER SYNCHRONIZER RING INSTALLATION

- (1) Apply gear oil to the synchronizer ring cone surface before installation.

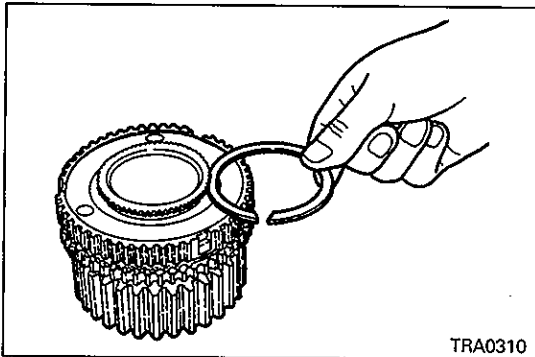

▶C◀ SNAP RING INSTALLATION

- (1) Select and install the snap ring which adjusts the 2-4WD synchronizer hub end play to the standard value:

Standard value: 0 – 0.08 mm (0 – 0.0031 in.)

23. CENTER DIFFERENTIAL CASE

REASSEMBLY DISASSEMBLY

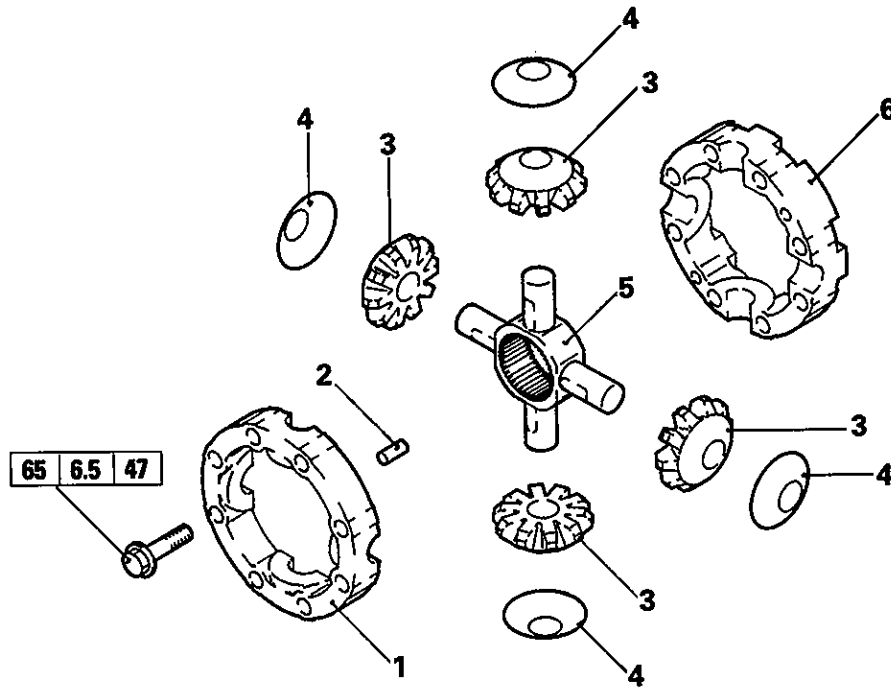

Disassembly steps

- ▶A▶ 1. Center differential case front
- 2. Dowel pin
- 3. Pinion
- 4. Thrust washer
- 5. Pinion shaft
- 6. Center differential case rear

 Lubricate all internal parts with gear oil during reassembly.

TRA0305

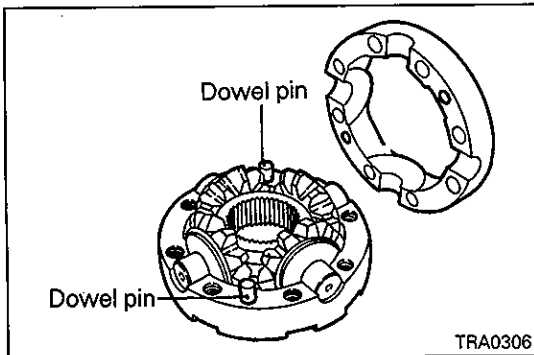

REASSEMBLY SERVICE POINT

▶A▶ CENTER DIFFERENTIAL CASE INSTALLATION

- (1) Pay attention to the positions of the dowel pins when reassembling, and make sure that the match marks on the outside circumference are in alignment.

TRA0306



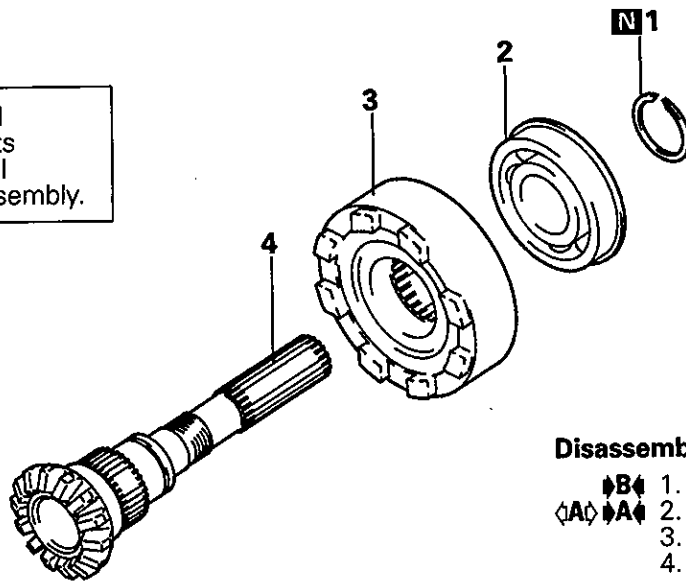

NOTES

24. REAR OUTPUT SHAFT DISASSEMBLY AND REASSEMBLY

 Lubricate all internal parts with gear oil during reassembly.



Disassembly steps

-  1. Snap ring
-  2. Ball bearing
-  3. Viscous coupling
-  4. Rear output shaft

TRA0301

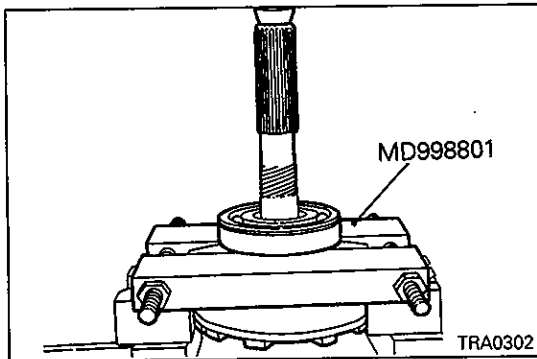

DISASSEMBLY SERVICE POINT

BALL BEARING REMOVAL

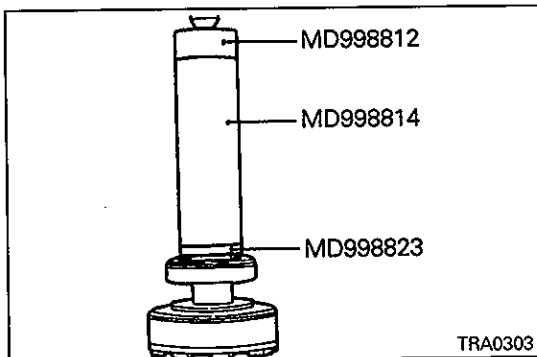

REASSEMBLY SERVICE POINTS

BALL BEARING INSTALLATION

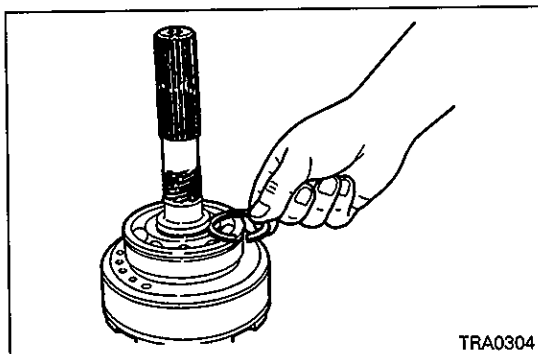

SNAP RING INSTALLATION

- (1) Select and install the snap ring which adjusts the rear output shaft bearing end play to the standard value.

Standard value: 0 – 0.08 mm (0 – 0.0031 in.)

NOTES

25. TRANSFER DRIVE SHAFT DISASSEMBLY AND REASSEMBLY

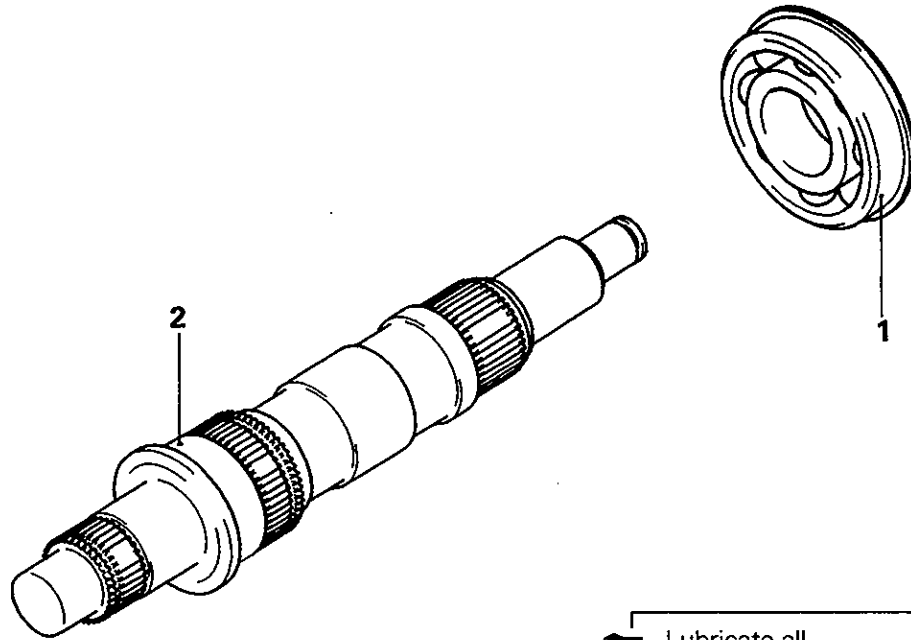

 Lubricate all internal parts with gear oil during reassembly.

Disassembly steps

- ◁A▷ ▷A◁ 1. Ball bearing
- 2. Transfer drive shaft

TRM0510

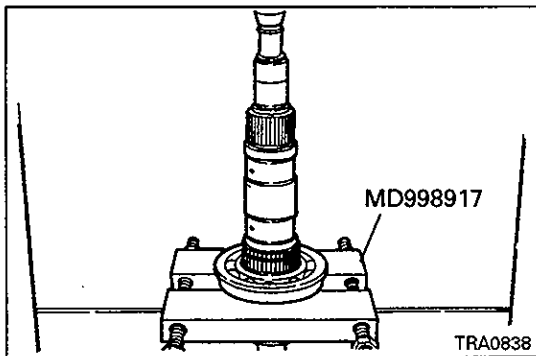

DISASSEMBLY SERVICE POINT

◁A▷ BALL BEARING REMOVAL

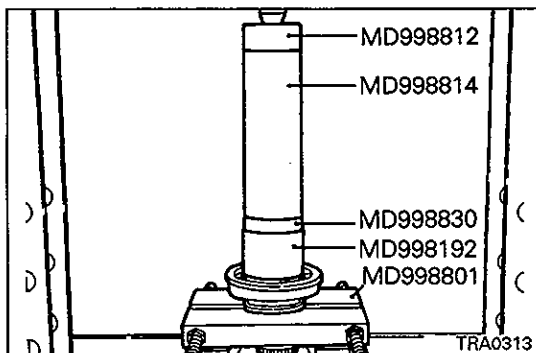

REASSEMBLY SERVICE POINTS

▷A◁ BALL BEARING INSTALLATION

NOTES

26. FRONT OUTPUT SHAFT DISASSEMBLY AND REASSEMBLY

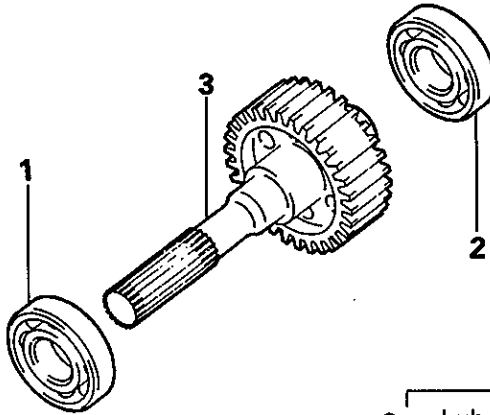

Disassembly steps

- ◁A▷▷A◁ 1. Ball bearing
- ◁A▷▷A◁ 2. Ball bearing
- 3. Front output shaft



Lubricate all internal parts with gear oil during reassembly.

TRA0319

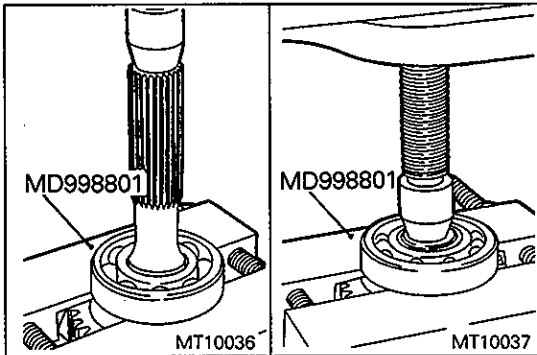

DISASSEMBLY SERVICE POINT

◁A▷ BALL BEARING REMOVAL

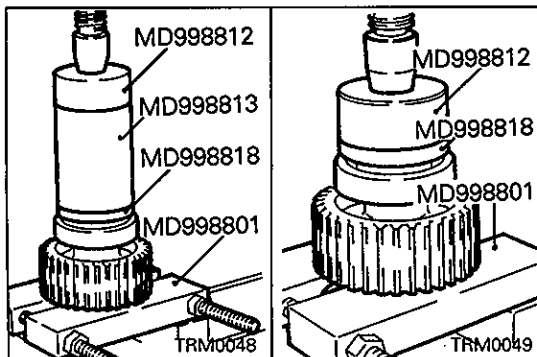

REASSEMBLY SERVICE POINT

▷A◁ BALL BEARING INSTALLATION

NOTES

27. SPEEDOMETER GEAR DISASSEMBLY AND REASSEMBLY

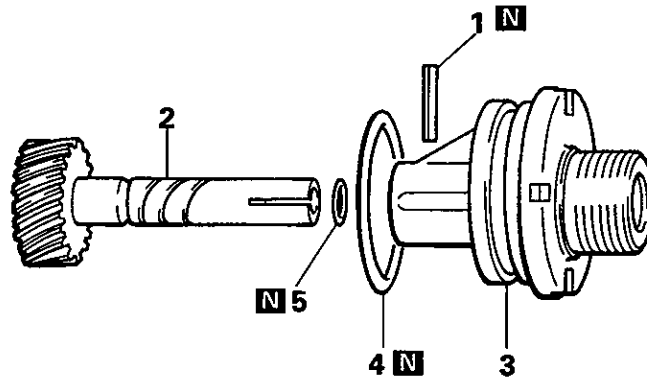

Disassembly steps

- ◆A◆ 1. Spring pin
2. Speedometer driven gear
3. Speedometer sleeve
4. O-ring
5. O-ring

 Lubricate all internal parts with gear oil during reassembly.

110008

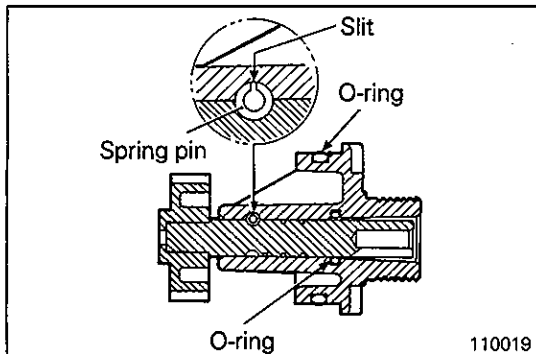

110019

REASSEMBLY SERVICE POINT

◆A◆ SPRING PIN INSTALLATION

- (1) Drive the spring pin into position so that its slit faces the direction shown in the illustration.

NOTES